



**Citation:** Stefania Mazzoni, Anacleto D'Agostino, Valentina Orsi (2019) Exploring a site in the North Central Anatolian Plateau: Archaeological Research at Uşaklı Höyük (2013-2015). *Asia Anteriore Antica. Journal of Ancient Near Eastern Cultures* 1(1): 57-142. doi: 10.13128/asiana-74

**Copyright:** © 2019 Stefania Mazzoni, Anacleto D'Agostino, Valentina Orsi. This is an open access, peer-reviewed article published by Firenze University Press (<http://www.fupress.com/asiana>) and distributed under the terms of the Creative Commons Attribution License, which permits unrestricted use, distribution, and reproduction in any medium, provided the original author and source are credited.

**Data Availability Statement:** All relevant data are within the paper and its Supporting Information files.

**Competing Interests:** The Author(s) declare(s) no conflict of interest.

## Exploring a site in the North Central Anatolian Plateau: Archaeological Research at Uşaklı Höyük (2013-2015)

STEFANIA MAZZONI<sup>1</sup>, ANACLETO D'AGOSTINO<sup>2</sup>, VALENTINA ORSI<sup>3</sup>

<sup>1</sup>Università degli Studi di Firenze, <sup>2</sup>Università di Pisa and <sup>3</sup>Università degli Studi di Siena

stefania.mazzoni@unifi.it; anacleto.dagostino@unipi.it; valentina.orsi@unisi.it

**Abstract.** The investigations started in 2008 by the University of Florence at the site of Uşaklı Höyük and in its territory have revealed a long local sequence of occupation from the Late Chalcolithic and Bronze and Iron Ages to the Late Roman and Byzantine periods. The presence of a stable network of settlements over this long duration attests to the strategic role of the area east of Yozgat for both the control of the routes across the Anatolian plateau and the exploitation of its favourable environment. Uşaklı Höyük was the main urban centre here, flourishing in the Middle-Late Bronze and Iron Ages, corresponding to the Hittite and Phrygian periods. In 2013-2015 the excavations brought to light sectors of two monumental Hittite buildings, a temple in the lower town and a palace on the acropolis. They show similar architectural elements, the extensive use of stones and monoliths and the regular organization of the plans, which belong to a common Hittite imperial tradition dating to the 15th-12th cent. In the late Iron Age, the acropolis was fortified by an artificial, sloping earthen rampart protected at its base by a stone *glacis*. In the late Roman period the lower town was rebuilt and the acropolis probably again fortified.

**Keywords.** Uşaklı Höyük, Hittite, temple, palace, stone architecture, rampart, Hittite pottery, Iron Age pottery, Zippalanda.

---

### UŞAKLI HÖYÜK: THE 2013-2015 EXCAVATIONS: INTRODUCTION AND ARCHITECTURE (Stefania Mazzoni)

Between 2008 and 2012 the University of Florence carried out an archaeological, geo-morphological and geophysical survey at the site of Uşaklı Höyük and in its territory (Mazzoni, Pecchioli Daddi 2015). In 2013, excavations started providing information on the chronology and urban characters of the settlement. The area where the ancient town of Uşaklı was founded is a plain crossed by rolling hills, rich in springs and

streams flowing among granitic and basaltic spurs; it was an ideal territory for exploiting agriculture and raising livestock (Mazzoni 2015). Uşaklı is located at the crossroads of important communication routes linking Cappadocia with the Pontus, eastern and western Anatolia, and nowadays Ankara with Sivas, and Kayseri with Çorum. This strategic position and the favourable environment, with its adaptive potentialities, account for the lengthy and continuous occupation of this area from the Late Chalcolithic, the Bronze and Iron Ages to the Roman and Byzantine periods. In this lengthy sequence, limited changes and fluctuations in the strategy of occupation and settlement distribution were registered by the survey: during the Late Chalcolithic and Early Bronze Ages and as well in the Iron Age villages and fortified citadels were located over natural spurs, from where the communities could manage to exploit their surroundings for a subsistence strategy based on agriculture and livestock; a somehow more consistent cluster of villages and farms across the plain and over the hills was documented only for the Roman and Byzantine periods and reflects the growth of the agrarian economy prompted by the imperial administration.

The unique Middle and Late Bronze Age settlement of Uşaklı Höyük, with its distinct and well conceived integration in the natural landscape and the crossway reveals a distinct strategy of foundation and choice as a regional central place. The site, consisting of a terrace of 10ha. and a mound rising on its southern side to 1138m, occupied a natural high spur and a plain which were surrounded by a semi-circular arc of low hills to the south and to the north by the meanders of the river Eğri Öz Dere, intersected by the stream Kötü Dere, which is fed by a spring to the south. It was, therefore, protected by this perimeter of hills and rivers, supplying water to men and agriculture, and on the same time it could provide visibility (and control) on the plain, to the south to the high granitic mountain Kerkenes Dağ, and to the north to the chain of the Zirzili Dağı which mark the direction of Hattusa, Alaca Höyük and the Roman town of Tavium.

The presence of materials of late Early and Middle Bronze Ages from the surface of the eastern terrace bordering the river Eğri Öz Dere and from the sounding under Building II (see here D'Agostino and Orsi) indicates that the first settlement was founded in this zone; however, the natural limestone hill which is at the base of the höyük may have also been occupied during these early phases, as the pottery from the surface of the slopes, from the core of the Iron Age ramparts and from the terrace sustaining Building III (see here Orsi) may suggest. In any case, it was during the Late Bronze Age that the settlement achieved an urban organization being furnished by monumental buildings (Building II-III) and surrounded by a circuit of walls (Building IV; Mazzoni 2015: 9, fig. 3). The Late Roman and Byzantine town enjoyed apparently these same extension and urban aspect: the upper citadel was fortified by a circular walling (Building VIII; Mazzoni 2015: 9, fig. 3, pl. 12, Operation 1) and the lower town was occupied by large well planned residencies (Area B: Building I; Area A: sector NW, see here D'Agostino). In the Iron Age, instead, only the acropolis was occupied and fortified by a rampart over a stone escarpment at its base (Areas C).

### *Building II (Area A)*

The investigation of the building, that the geophysics survey shows as extending over 875 square metres on the eastern terrace, started in 2013 and up to 2015 600 square metres were cleared out (Plan 1). In the north-western sector (I19D1+J19A1, J19B2, C2), immediately under the topsoil, two long rooms, SU 26 (Fig. 11) and SU 75 (Fig. 16) appeared with their northern wall (SU 20) 2.70 m. large and three parallel walls crossing it (from W: SU 19, 27, 67) of 2.30m. Demolished blocks were found scattered in the rooms and the open space to the north-west where also flimsy alignments attest to a late re-use. Wall 67 is crossed on its eastern side by a wall (SU 1), 2.50m large, which abuts on the east onto a massive structure of rough boulders, a sort of plinth, laid on a deep foundation of small stones; this was the first structure to be excavated in 2013 (J19B4, C4, B3, C3), as SU 1+4 and completed in 2014 (J19D4, K19A4). The northern front of it seems to be constituted by the prosecution to ESE of the wall bonded to wall 67, i.e. SU 1. A long wall, oriented NNE-SSW (SU 111), large 2.65m, constitutes the eastern face of this solid structure walling also the unit which appears to its south.

The north-eastern corner of this block is largely damaged by the recent demolition; to the north of the plinth and the northern front SU 1 (Fig. 9) a line of blocks, or possibly a largely ruined wall (122b), extends to the north

where scattered stones (125) appear on the same level; the space to their west (126) may be a further room. East and parallel to wall 111 a line of stones with the same alignment (122) appears and possibly close further rooms in this sector. Relics of small walls built with pebbles and medium sized stones, fillings of small stones represent the poor evidence of a recent phase of use in this sector.

Wall SU 111, as noted above, constitutes the long front of the so far investigated south-eastern area; it closes to the west two small rooms, SU 127 (Fig. 8), 134 (Fig. 6). Wall 111 is bonded to the south to an orthogonal wall (SU 133), defining the northern side of a further room (SU 131).

The long wall 1, connecting the north-western block with the two parallel rooms to the eastern block with the solid plinth (1+4) seems to constitute the northern face of the central zone of the unit so far excavated. To its south open a small room (SU 33), large 4.25x1,60m, and a long room (35), 4.60x7.50m, probably a court; this room is closed to the north by wall 133, large 2.40m, and to the south by a parallel wall, SU 149, large 2.40m. In this sector there is evidence of limited squatting and re-use of the ruins with flimsy walls (SU 62, SU 68) and a sort of irregularly cobbled bench (SU 20).

The southern sector was exposed mainly in 2015 in J19 D3, K19 A3, K19 B2-3, K19C2+3+4). A large room in J19D3 is walled to the north by SU 132, large 2.25m, to the east by SU 111, and to the south by another wall, large 2.40m. This wall crosses to its south the wall SU 145, large 2.50m, built by large and well dressed stones and slabs; this wall crosses to north-west SU 149, large 2.50m, and to the south wall SU 148, large 2.50m, delimiting a room. A further room (152) opens to the south, being delimited by walls 149, large 2.50m, and 154, large 2.20 (exposed), crossed by walls 153, large 1.20m, and 161, large 2.25.

To the east of wall 145, the area is apparently free and was possibly open-air; scattered stones appear on the ground (155) in a sort of irregular low platform (?); here a few Roman tiles were collected.

A deep sounding along the northern side (see here D'Agostino) has revealed a dense accumulation of homogeneous layers of a clayish earth. This layer is 1 m 80 deep and covers eight cobbled floors (SU 41, 52, 54, 66, 70, 72, 74, 77), each separated from the other by a thin accumulation of clayish earth.

### *Interpreting Building II*

The preserved part of Building II consists of a massive groundwork of walls made of large, undressed stones. Only one course was preserved and was put to light immediately beneath the topsoil; however, and in a small zone of the eastern side the survey revealed a few granitic blocks on the surface with a clear alignment (Mazzoni 2015: 6-7, pl. 3.3) that may have represented the remains of a second course, as they were at a higher level than those excavated. These surface blocks were dismantled by the landowner to enlarge the ploughing area before the starting of our operations (Fig. 17); besides, these blocks were better preserved and more exposed in the photos published by P. Meriggi in 1971 (Meriggi 1971: pl. X:2), a fact that shows how this structure suffered reiterated activities of removal in modern times by the local farmers. We can consequently suppose that the structure had to be constituted in origin by two courses of blocks visible over the floors.

There is no evidence of the original floors apart from some limited zones such as the northern corner of the small room 26, showing fragments of a thin coating of earth mixed with loose gravel (Fig. 18). The finding of a miniature vase (U13.A.30) (Fig. 26) there may support this identification but, on the other hand, two other miniature vases (U13.A.29,42) (Fig. 26) were found in the filling of this area proving that these materials were random remains from the original inventories of pottery and were not preserved in place. We have also to stress that nowhere we have evidence of remains of coating with a buff/whitish plaster in the rooms brought to light; this technique of floor refinement is instead documented in Building III (Area D). We may then probably identify in Building II nothing else than a preparation which could provide a good drainage and stability to the floors. In this case, however, this preparation may have been not too thick, as the foundations of the walls were exposed at the base of the preserved course of stones. The floors had to be laid at the level of this course, i.e. at the base of the groundwork, as we know from buildings of this phase of other sites. However, these soils were all worn in a simi-

lar way as if they had been exposed to weather for long. No waste pits or pits for digging stones or for retrieving materials from the rooms were identified, a fact that may indicate that the building stood probably for long after its abandonment, being then gradually demolished in the course of a very long time. The presence of scattered materials of the Iron and Roman Ages, such as tiles, and of flimsy stone alignments suggests a late occupation and use of the ruins for quarrying stones and dressed blocks; these had to be employed for building the late Iron Age *glacis* of the acropolis, and as well the walls of the Roman houses, which adjoined the ruins of Building II to the north-west and north (Building I).

The thick wall socles, unplastered and made of dry masonry, were laid over foundations of smaller stones whose alignments protrude sloping slightly down beyond the line of the walls of the socle; these foundations were more or less deep, being composed by different courses (compare Figs 12 and 13: room 127) according to the size of the walls. Foundations and groundwork were laid over an artificial 2 m high terrace consisting of a uniform layer of earth raised over eight cobblestone layers (see here D'Agostino). This deep underground structure probably aimed at withstanding the heavy pressure of the megalithic groundwork and raise the building over the level of the surrounding old topsoil; the socle in its turn had to provide a solid base and a regular horizontal level to the structure.

This groundwork was composed by walls of different measures, made of stones and boulders of various size and cutting; these were also laid in different ways. The walls so far exposed can be 2.50/2.20 and 1.20 large; only wall 20 is 2.70 m. Our excavations started on the northern side of the building (following the indication of the geophysics image) and here the walls present a homogeneous regular technique of bonds; they are, in fact, built up by two faces filled by rough small stones; the stones of the faces are laid as headers with their length across the wall in order to fasten the texture and bind the face to the backing. This system of bonding could provide a more stable base for the upper course which had to be made of heavy granitic stones and improve the static stability of especially the façades of the building. This bonding system is found on the outer side of wall 20, large 2.70m, but not on the inner partition walls (19, 27, 67) of rooms 26 and 75 to its south. Wall 1 closing to the south rooms 35 (Fig. 10) and 33 shows a similar bond in both faces; in the plinth 1+4 only the northern face (1) has the headers, up to the join with 111, whose faces are, instead, characterized by boulders or big stones. A similar bond with long stone as headers appears also in wall 148 to the south. It is noteworthy that in some walls (111, 145) stones appear to be bond in a stretcher composition, i.e. with the larger part of the dressed block exposed on the front of the wall. However, given to the quite disomogeneous preservation of the structure whose walls were dismantled, and many stones fallen from their original setting inside the empty spaces, it is difficult to understand the technical nature of the differences in the texture and technique of stone bonding. We cannot say if they reflect the history of the construction, its inner phasing or, instead, are connected with the history of its dismantling.

The plan of Building II seems to include different blocks juxtaposed which may represent units and include quite small spaces, and a few larger rooms, probably open-air, or courts. Looking at the aerial view of the exposed part of the building (Plan 2), the eastern block seems to include double walls, placed side by side; at the north-eastern corner (?) a sort of square block seems to be laid as a tower-like structure with a core constituted by smaller stones. We could not identify clear alignments nor spaces which may have been filled by fallen down stones, giving the idea then of a solid structure. A few small empty spaces appear as a sort of casemate composition but we cannot grasp their nature and function. Only two rooms are legible in the centre, (SU 35: 132/133) both found filled by numerous large blocks fallen from the upper course. The north-western block is composed by small, long and parallel empty spaces which correspond perfectly to the image furnished by the geophysics analysis. This might be interpreted as the base of a staircase.

Looking at a preliminary schematic plan (Plan 3), which constitutes a tentative reconstruction of the architecture exposed in the years 2013-2015, a certain irregular organization of the blocks and consequently of the original units stands out as a distinct structural feature of this building. Rooms are relatively small, walls present various sizes; there are apparently no clear outer limits. As the northern wall of the north-western block is 2.70 it may be identified as a perimetral wall for this zone and in this case the block probably abutted to the north. Walls 1 and 111 being 2.5m may have also been perimetral walls, and the large open spaces to the north and east represent then external sides or possibly large courtyards.

Concerning the identification of the nature and function of Building II, we can rely more on its architectural character than on its plan, too little of which is known. Size and drafting of the stones, the use of granitic boulders, the use of larger foundations and of a probably thick terracing, indicate that this was certainly a monumental structure. On a more speculative ground, it is possible to recognize a quite sophisticated architecture, a well conceived planning (despite its irregular lay-out) which resulted from a specialized craftsmanship and an expensive investment of materials and labour forces.

Architecture and the style of the stone-working can be compared with the Hittite institutional buildings, temples and palaces. However, if we have to suggest some parallels we may better address our investigation to the temples, and specifically to the earlier temples in Boğazköy/Hattusa (2, 3, 5) characterized by a somewhat irregular layout of the different units (Schachner 2011: 176-177; Temple 5: Krause 1945). The monumental scale of other temples in the capital and as well at Kuşaklı Höyük/Sarissa with their organization of units and regular structuring of the spaces around very large courtyards belong to a monumental conception which was probably unparalleled elsewhere.

A further element for a speculative understanding the nature of Building II as a temple, as already noted (Mazzoni, D'Agostino 2015: 166), can be provided by its position, facing the river to the east and looking south to Kerkenes Dağ, in margin to the proposed identification of the site with the town of Zippalanda, sacred to the Storm-god, and Kerkenes Dağ with the mountain Daha, near to the town and seat of the cult of this god (Torri 2015; see here the contribution by G. Torri). This hypothesis is now corroborated by the discovery of six fragments of cuneiform tablets concerning letters, a feast, a ritual with a myth and an oracle, stamps and a clay sealing with the impressions of a Hittite stamp seal that show that Uşaklı must have played an administrative and political role in the imperial Hittite organization, between the 15th and the 12th cent. B.C. (Pecchioli Daddi, Torri, Corti 2014; Archi et al. 2015; Poetto 2015).

The monumental character of the architecture, the size and topographical setting in a landscape marked by distinct geographical features, which may have been charged by ideological concepts, do support the identification of Building II as a temple; if we do believe that Uşaklı Höyük were Zippalanda, this may have only been the temple of the local Storm-god.

### *Building III (Area D)*

In 2015 a long E-W trench (Q15 A2-3; Q15 B2-3) was opened in the southern slopes of the mound with the main intent of investigating Building III, a legible and certainly relevant edifice revealed by the geophysics analysis on this sector of the höyük as extending at least 65m E-W by 20m N-S (Mazzoni 2015: 8-9, fig. 3) (Map 4a). The excavations have revealed here a sequence of Iron Age levels of occupation over the destruction level of this building (see here D'Agostino and Orsi). The earlier Iron Age occupation overlaps over the raised remains of Building III. Two rooms were put to light: to the west a large room (U 58) and on the east a long small room (SU 59) (Map 4b); its western wall, oriented N-S, SU 6, and its northern wall, oriented E-W, SU 47, were preserved respectively for 1.56 and 1.25m, and were both made by dry walling technique with two faces built of drafted stones and a core of rubble. The walls to the south, SU 36) and to the east, SU 61, were instead cut by the slope and have only one course of small stones preserve. The floor of SU 58 is constituted by a beaten earthen soil (SU 46) which is laid over a clayish hard soil (SU 49), and was connected to the walls SU 6 and SU 36. A further similar hard soil (SU 62) appears immediately under SU 49. The other room to the east, SU 59, is a long room (3x1.15m) walled by SU 6 on the east, SU 60 on the west and SU 7 made of of small stones. The room was filled by a deposit of broken pebbles and bricks (SU 3) over the beaten earthen floor SU 65.

These rooms are limited and fortified to the south by a massive wall, SU 8, large 1.70m; on its southern front, it was built of well dressed blocks bounded by small stones and carefully joined (Fig. 31). This front, with its three courses preserved, has been put to light for a length of 8m. The wall constituted also the retaining wall of the high terrace over which the building raised, as documented in a trench carried out under the floor (SU 54) of room

SU 58 and its preparation of hard clayish soils (SU 49, 62) (Fig. 35); this preparation rests on a thick accumulation made of quite compact fillings (SU 63, 64, 67, 69, 70, 71, 73, 74, 75). The soil SU 64 to the west is apparently related with a N-S wall (SU 68); SU 6 at higher level appear to follow its alignment and orientation. This deposit constitutes a sort of high terrace supporting the foundation of the room (SU 58) with its walls. The excavation was also deepened under the level of the foundation of wall SU 8 (see here D'Agostino) putting to light a sort of substructure for isolating the building, made of different fillings of earth, clay, rubble of rocks, and earth of bricks, which rests on the virgin soil.

The rooms with their floors were empty; no materials were found in place as if the building had been abandoned and voided of all its furnishings and facilities. It is consequently clear that it was destroyed by fire after its abandonment.

In a preliminary way, we can recognize some elements characterizing Building III as a remarkable feature of the urban landscape of the town: a sophisticate architecture and a regular plan, a massive retaining wall built with well dressed stones, a high and dominant position over an elevated artificial terrace, its location over a natural hill, its dimensions as given by the geophysics survey (65 E-W along near the whole of the southern side of the mound). Considering that the exposed sector does match perfectly to the plan revealed by the geophysics survey, we may compare Building III with the palace of Maşat Höyük (ancient Tapikka) in north-eastern Anatolia (Özgüç 1982: pl. 4), which extended over the whole surface of the acropolis in a prominent position over the surrounding plain.

#### *The rampart and the glacis of the Iron Age (Area C)*

On the eastern side of the mound a 25m long trench (Area C: M17 C3-C4, M18 C1-4; M17 B3-4, M18 B-4) was open from the top to its base (Plan 5); on the surface of the upper zone two fragments of tablets were recovered during the scraping operation in 2012 (Tablets UK12.E.3, E4, E5: Archi et al. 2015: 351-352) together with abundant materials of the Iron and Late Bronze Ages (D'Agostino, Orsi 2015: 182-184; Mazzoni, D'Agostino 2015: 170-175). The excavations in 2014 brought to light two further fragments (UK.14.E.3, 62, from M17 C4 and M17 D13: Ibidem: 352-353), while another one was found in the 2015 campaign (UK.15.E.62: Ibidem: 353, from M17 D3).

Excavations have revealed here the escarpment wall of the acropolis constituted by an earthen rampart strengthening the upper slope of the old mound and a stone *glacis* revetting its base (Figs 41-42). The structure was composed by different architectural units. The upper surface of the rampart was protected by a revetment of flimsy stone walls which formed a system of grids that bounded and fastened the steep earthen slope (Fig. 54), which may have been a later addition to secure the top of it. The earthen rampart included an artificial massive deposit contained by slightly divergent radial walls (such as "flying buttresses") which constituted a sort of inner backbone of the rampart; these were laid deeply inside the deposit and are preserved for a height of 3m. These walls relieved the pressure of the heavy mound over the *glacis* and, on the same time, strengthened the inner deposit. Two of these walls, oriented east-west, and descending from the middle portion of the mound, have been exposed; one to the south (SU 9/21/30); and a second one to the north (SU 45, 73, 75). These walls were built different technique and possibly in subsequent stages with a lower layer constituted by burnt bricks and an upper level by small stones overlapping directly the walls of the burnt bricks (Figs 47-48, 51).

The space between these walls was artificially filled up by an accumulation of layers (SU 43, 46, 47, 68, 69) (Fig. 43) of earth containing debris from the demolition of architecture and materials of a building of the Late Bronze Age (including the fragments of tablets). This filling constituted the core of the rampart.

The *glacis* exposed at the bottom of the trench (M18 C1-3) was composed by rows of blocks stepping down to the base of the slope (SU 35, 37, 41, 42). The original face of the *glacis* is preserved in the northern sector at some depth and shows a regular bonding and well dressed stones (Fig. 45). In the central and southern part of the section actually recovered the outer face is probably composed by a thick layer of stones collapsed from the original outer revetment, and has consequently a quite irregular aspect. Despite its preservation, however, the *glacis* reveals a quite solid and imposing character.

Excavations have shown that this south-eastern slope of the central mound was walled and reinforced by an apparently single building operation which was conceived for both defending the acropolis and strengthening its probably steep slopes, preventing their subsidence, and as well for filling some deep void or a zone severely collapsed, maybe related with the building from which came the bricks, materials and tablets found in the deposit of the rampart. The earthen rampart is, in fact, a very thick and massive structure intended to provide a structural support to the acropolis slopes, at least in this area. However, the final structure constituted a defensive system making the acropolis unapproachable. This structure offers a quite unique case of earthen rampart built over a stone *glacis* for the Iron Age. The technique of the stone lined scarps and *glacis* are certainly well documented in the area at Tilkigediği Tepe, Keykavus Kale and at the Göz Baba “Tumulus” by the regional survey carried out by G. Summers in the frame of the Kerkenes Dağ mission (Summers, Ahmet 1995: 46-53). Comparing the *glacis* found at Uşaklı (Mazzoni, D’Agostino 2015: 179) with these stone escarpments which had been dated to the Achaemenid period given to their different and inferior technique of stone-working in respect to stone *glacis* of the late Phrygian city at Kerkenes Dağ, we could not provide a clear attribution inside this sequence to our case. The documentation gathered, instead, in the later campaigns make us more confident on a datation in the Late Iron Age. It is, therefore, possible to date the emergence and diffusion of this walling system in the region in the late Iron Age, in margin to a strategy of control of the territory exerted by the political institution held in Kerkenes. Therefore, the fortified citadel of Uşaklı may have been part of a regional network of castles guarding the routes and the hinterland of Kerkenes.

#### *Building I and the Late Roman Period occupation (Area B)*

The town was densely occupied and rebuilt during the Late Roman period (2<sup>nd</sup>-6<sup>th</sup> cent. AD). Extensive quarrying of the walls of the Hittite Temple II was carried out in this phase and is documented by the traces of squatting among its ruins. A perimetral wall with a socle of well dressed slabs was built on the summit of the citadel which was probably occupied by a fortified *castellum* (Building VIII: Mazzoni 2015: fig. 3; D’Agostino, Orsi 2015: Operation 1, pl. 12). To the north of the Hittite Temple, a large well planned building (Building I) is shown by the geophysics survey; this was first interpreted as a Late Bronze Age structure owing to its proximity to Building II, its size covering an area of 710 square metres and including ten rectangular and parallel rooms, (Mazzoni 2015: 8, fig. 4), its orientation that was aligned with the orientation of the town wall (Building IV: Mazzoni 2015: 9, fig. 3) but not with the one of Building II; regular plan (Plan 7).

Excavations carried out in its southern zone in 2015 (H18 E4/H19 C1) exposed a large room, immediately under the surface, with its walls (SU 1, 13, 14, 3) made of different courses of rough stones (Fig. 60); they have also shown that this room underwent different changes and various sub-phases could be documented (see here D’Agostino). Other remains of this period were exposed in square J18 A1, on the north-western edge of Building II; here, a large room (SU 123) (Figs 64-65) was excavated with its northern (SU 106) and western (SU 102) walls made of rough stones. Portions of its external beaten earthen floor (SU 128) were found covered by tiles (SU 121). The room, filled by a thick collapse of stones and tiles, had an accurate paved floor (SU 124) of large flagstones and appears to have been reduced in a subsequent phase by the addition of a coarse wall made of rough stones (SU 115) parallel to the northern wall.

The accurate architecture of these buildings, the different sub-phases recognized so far give indication of a substantial and probably not too short occupation of the site during the late Roman period and, in fact, as documented by the survey, the whole region and the hinterland of Uşaklı were intensively settled with rural villages and farmsteads in this phase (D’Agostino, Orsi 2015: 177-179, 186-188). As said before, this process can be understood in the context of the economic flourishing and population stability that the region underwent thanks to the Roman agrarian politic (Mitchell 1993: 143-147). The main Roman centre in the region was Tavium identified with the site of Büyüknemes, north-west of Yozgat (Strobel, Gerber 2007) in the basin of the Delice Irmak, ancient Kappadox (Strobel, Gerber 2010: figs 7, 8), which was the territory of the Galatian Troikoi; this town was organ-

ized as a *polis* of the Sebastenoi Tokmoi Taouianoï (Strobel 2009: 130-131). During the Roman period Uşaklı Höyük may have been included in its sphere of administrative control. K. Strobel has proposed its identification with the town of Podanala (Strobel 2002: 26-27; see the map in Strobel 2009: fig. 1; note 268, p. 177 for further bibliography), connecting this name to Zippalanda.

### *Preliminary considerations*

The excavations of Uşaklı Höyük reveal a history of occupation which is coherent with the picture provided by the survey. Continuity throughout the Bronze, Iron Ages and Late Antiquity in the exploitation and use of this area is evident as are the changes and the fluctuations also documented on the site and its territory. However, on the basis of the present documentation, we cannot say whether these changes were connected with a shift in the population of this area and its demographic consistency. Processes of destabilization or, instead, renovation and resilience are certainly clear in our archaeological documentation and in the urban history of Uşaklı; they may have been also reflected in the population of its territory. But, the data are not always equivalent; a coherent picture of intense occupation in the area mirroring the urban growth of the site can be obtained only for the Roman and Byzantine periods, while for the Iron and Late Bronze Ages the fact that only the site provides documents may suggest that the countryside was only marginally occupied in these phases or that its occupation had a more ephemeral character, undetectable by archaeology. However, the data provided now by the excavations offer us some clues for further albeit preliminary considerations.

The excavations show a process of continuity of occupation and also some not inconsistent changes. A major break in this continuity concerns the town of the Late Bronze period. Buildings II and III are apparently abandoned; if Building II does not present evidence of violent destruction given its spoliation during the Iron Age and the Roman period, Building III, instead, was found filled with the debris of its collapse, at least in the limited sector exposed; its floors were found burnt and completely empty. This evidence cannot but indicate that its collapse and destruction by fire took place after its abandonment. While there is sparse and inconsistent evidence (few pits) of a post-Late Bronze phase or transitional period, a phase often debated on a vast regional scale, evidence of occupation on the sole acropolis is obtained for the Middle and especially Late Iron Age. There is, consequently, or a gap in the occupation of the settlement, or a very flimsy use of the abandoned structures, as some Early Iron Age pits may demonstrate, possibly of non permanent nature; however, the duration of this phase cannot be fixed on the basis of the present documentation. This evidence can only indicate that in Uşaklı, from the Bronze to the Iron Age, there was a drastic reduction of the settlement to the sole acropolis following the abandonment of the large and monumental Hittite town and that a substantial occupation did not re-emerge before the Late Iron Age.

We do not know how or why the Late Bronze Age town collapsed. No signs of a destruction affecting contexts in their primary function and use are preserved but many materials, bricks, stones, and a tablet found on the surface of the site (Archi et al. 2015: 350-351, UK09.E.2, pl. 43) were severely burned; by consequence, as already stressed, a destruction by fire can be suggested as a final term for the life of the town; in any case, the burnt floor in Building III shows that this took place after the abandonment and possibly collapse of its main buildings.

It is obvious to relate this event to the fall of the Hittite empire in the 12<sup>th</sup> cent. B.C. with its still debated movers, invasions and conflictuality at the western (Sea Peoples) and northern borders (Kaskaean), famine, inner dynastic problems; this was certainly a major process that strongly affected the socio-political structure of the Anatolian Highlands prompting a substantial disruption and a radical political transformation. The area of Uşaklı Höyük, in the core of the empire, strictly followed the fortune of the capital Hattusa and all the regional towns; the town was probably abandoned when the capital was transferred to the south and the administrative centres relocated.





**Plan 1: Area A, Building II**

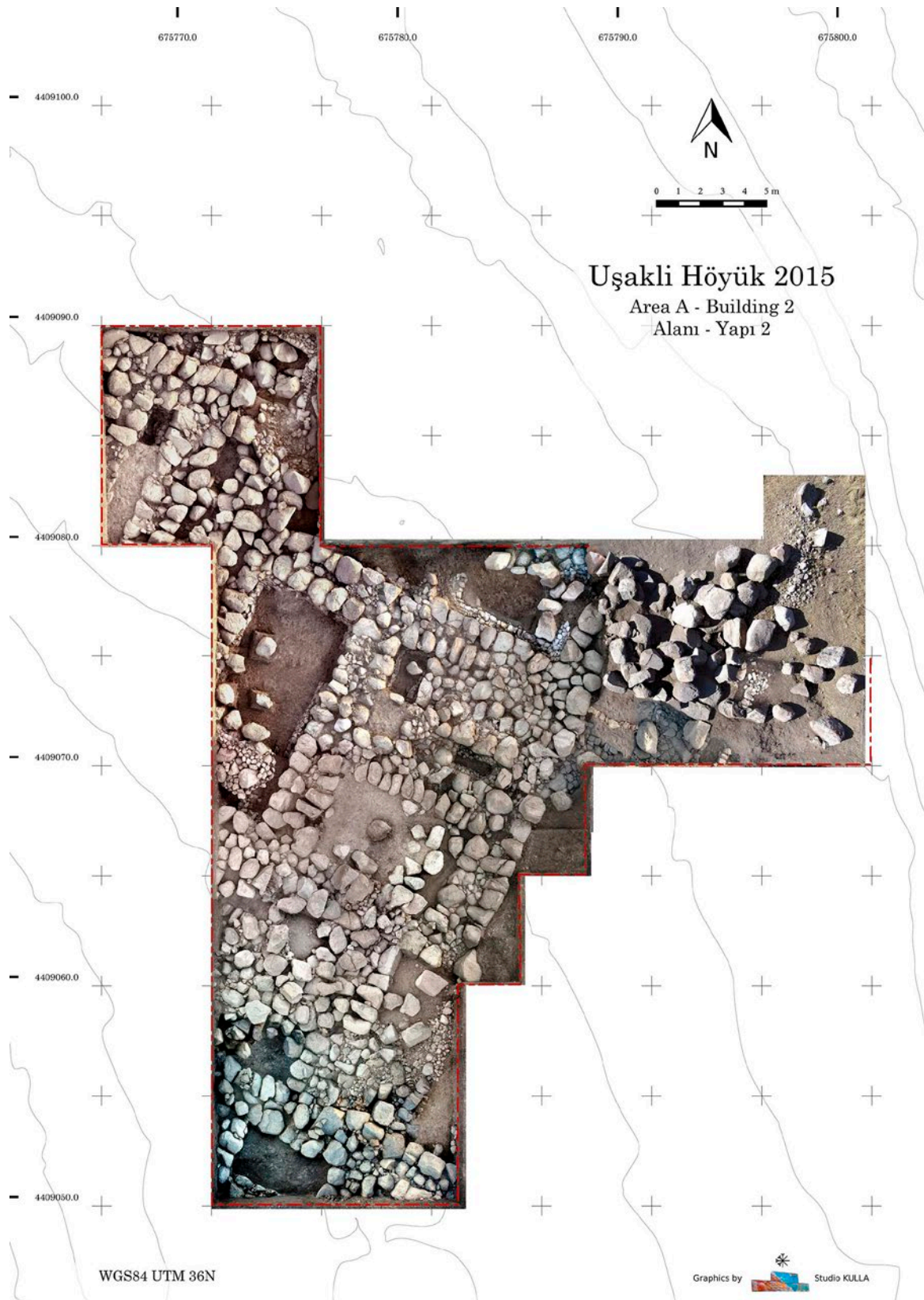

Plan 2: Area A, Building II, orthophoto

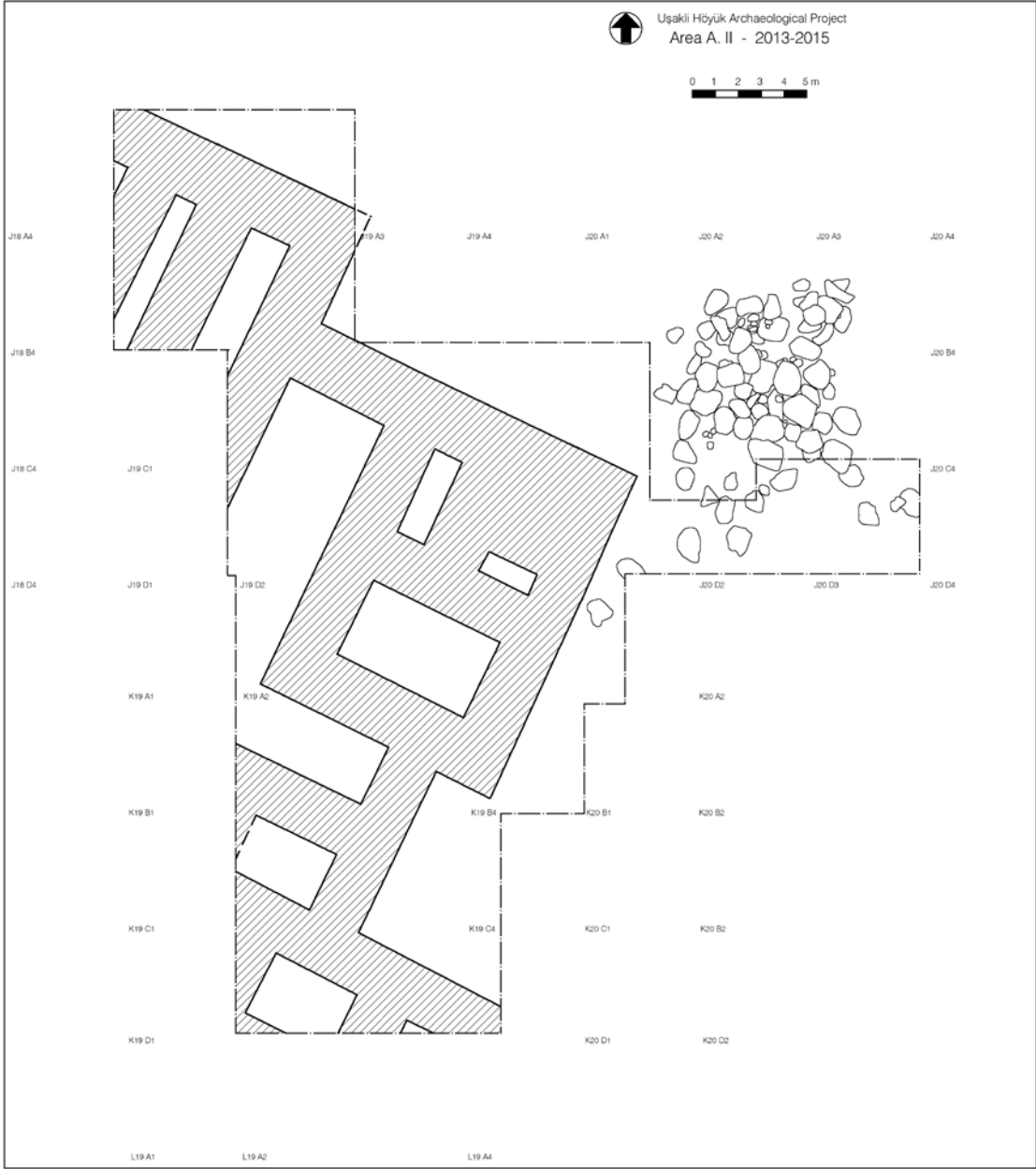

**Plan 3:** Area A, interpretative sketch plan of Building II, tentative reconstruction

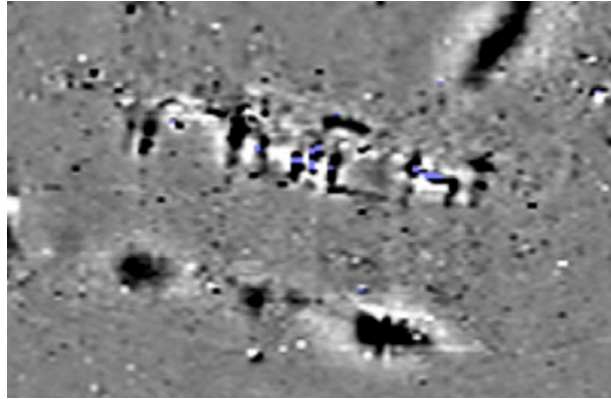

**Plan 4a:** Southern slope of the high mound: the anomalies registered by the geomagnetic survey



**Plan 4b:** Area D, Building III

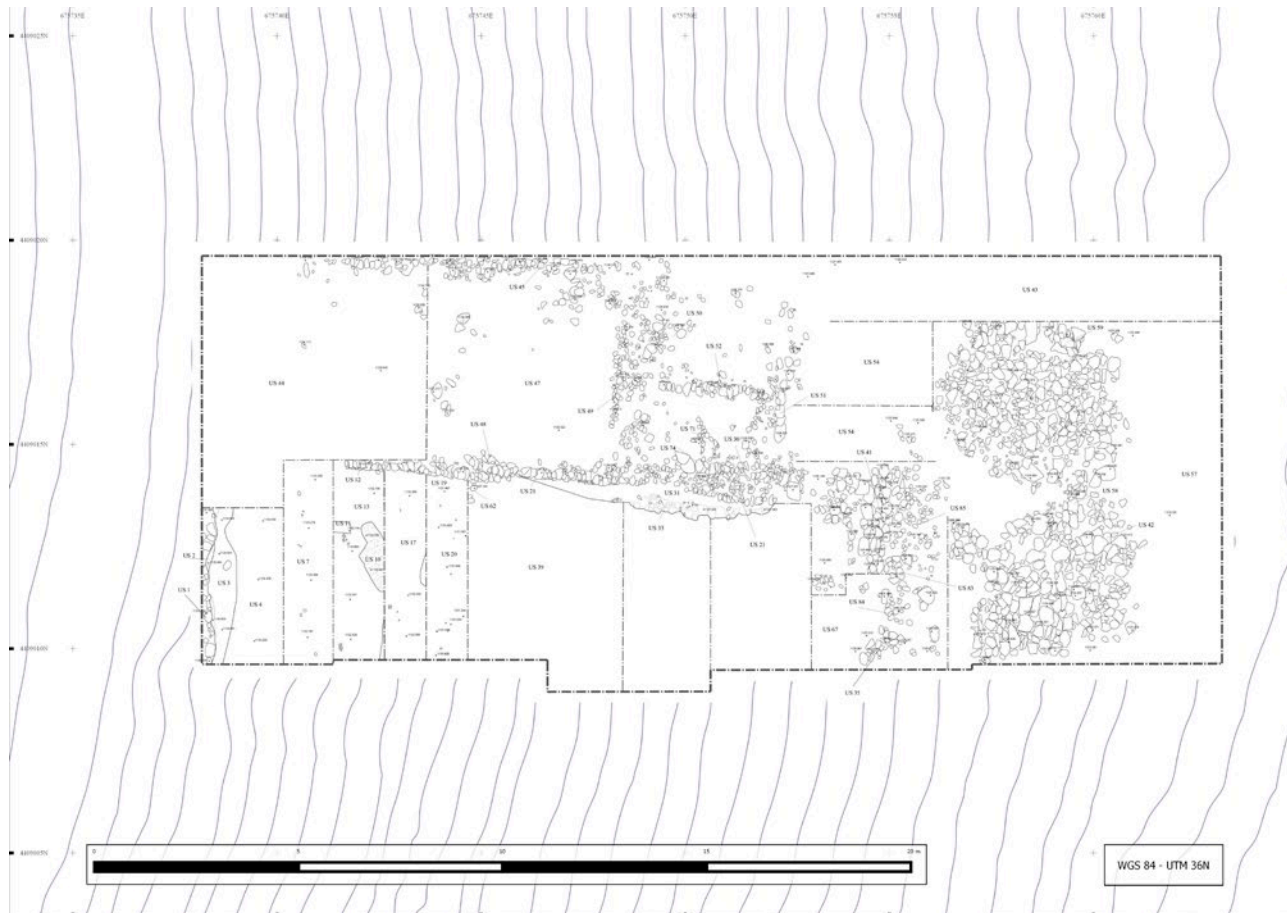

Plan 5: Area C (west-east oriented)

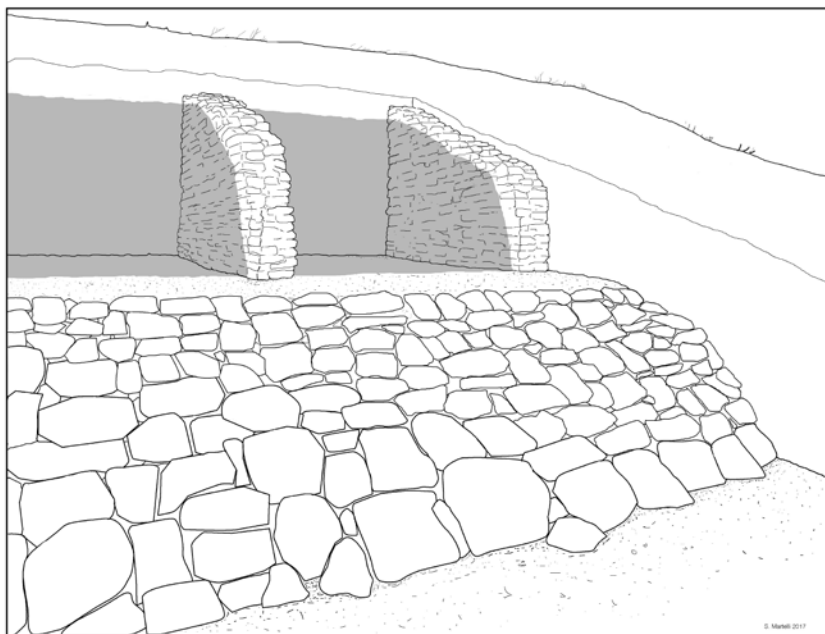

Plan 6: Area C, tentative reconstruction

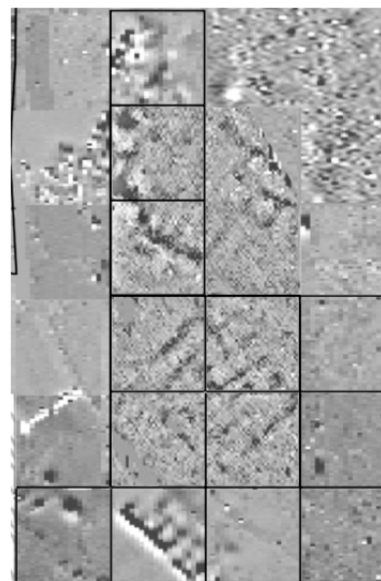

Plan 7: Area A, anomalies registered by the geomagnetic and geoelectric prospection

DEFINING THE UŞAKLI HÖYÜK ARCHAEOLOGICAL SEQUENCE:  
STRATIGRAPHY, CHRONOLOGY AND MATERIALS  
(Anacleto D'Agostino and Valentina Orsi)

*A stratigraphic summary*

Anacleto D'Agostino

The excavations carried out between 2013 and 2015 enabled us to outline an initial general sequence of occupation and connect the evidence scattered on the surface to a general stratigraphic framework. In the light of work carried out at the top of the terrace and on the slope of the high mound, three main periods of occupation have been documented by structures and contextual materials. Architectural remains dating to the Late Bronze Age and Iron Age have been exposed in Area A, C and D whereas those belonging to the Common Era have been identified mainly in Area B (Fig. 1). The results of the preliminary multidisciplinary survey enabled us to allocate the excavation trenches according to the periods to be investigated (D'Agostino, Orsi 2016).

Area A

In Area A the original archaeological context is disturbed by re-use of the older structures in ancient times and by modern mechanical ploughing (Mazzoni, D'Agostino 2015, 160-169; D'Agostino, Orsi 2015). This state of affairs is due to the fact that the remains are not far below the surface in an area until recently used for agricultural purposes and possibly also because for centuries the walls and their elevation were visible and dismantled in order to recycle building materials (Figs 2-4). Below the incoherent agricultural surface, in certain parts of the area, a layer of more compacted soil and stone debris represents the upper archaeological layers (Fig. 3, a). The underlying architectural remains of Building II consist of foundation walls in massive granite stones (Figs 5-7) lying on a sort of under-foundation of medium-sized stones, with a brown soil, of the same texture and characteristics as that on the surface, filling the spaces between the thick walls (Figs 8-13). Over the course of time, some of these irregularly shaped boulders were dismantled and displaced (Fig. 14-16) and others recently moved to the edge of the terrace as they hindered ploughing (Fig. 10, top left and Fig. 17). The stratigraphy is consequently compromised with regard to the original setting and items are not found in primary contexts. The debris from the collapse of the walls has not been preserved either. Small portions of floors in compacted earth have been exposed in two rooms but cannot be firmly ascribed to the original phase of the building (Fig. 18). The excavations enabled us to reconstruct a brief sequence composed of two main phases on the basis of structural modifications: the building phase (Fig. 19) and a few traces of re-use after the abandonment of the building. The latter evidence consisted of irregularly shaped thin walls and small installations (Figs 20 and 21) that were added later and some spaces between the foundation walls converted to a different use, possibly habitations (Fig. 22).

Traces of some preparatory work intended to level and reinforce the area for the building of the structure has been revealed in a small test sounding on the north-eastern side of the building (Fig. 23). Here a sequence of eight cobbled floors separated by thin accumulations of soft clayish earth containing pottery and animal bones has been exposed (Figs 24-25). The texture and consistency of the layers of soil sandwiched between the different cobbled layers are similar to each other and would appear to be the result of intentional filling. The evidence cannot support a convincing interpretation of the area as a sequence of earlier external planking levels but we can suggest that it relates to a preparatory work intended to level, strengthen, or set apart the area before the construction of Building II. However, at the moment we cannot rule out the possibility of a more specific purpose for this work (connected with a ritual to clear or to purify the area?). The pottery sherds found in these layers furnish further elements enabling us to date the construction of the building to the Late Bronze Age.

Among the small finds found in relation to Building II, three miniature vessels (Fig. 26) and two fragments of curved, crescent-shaped 'loom-weights' (Fig. 27) can be assigned to the original occupation phase dating to the Late Bronze Age. Similar objects are well-known in the sites of the central plateau and have been found, for exam-

ple, in Alaca Höyük (Koşay, Akok 1966: lev. 19) and Alişar Höyük (Von der Osten 1937: fig. 300), to quote some parallels but also at Tell Atchana (Akar 2017: 11 and fig. 1.7). In particular, the pinched miniature plate (left, top) finds parallels with specimens found in Boğazköy, in the valley west of Sarıkale, and considered a forerunner type of later votive cups (Schoop 2009: 155 and fig. 15).

#### Area D

In Area D, on the southern slope of the mound, a trench was opened in 2015 within the perimeter of Building III, visible in the geomagnetic plot (Fig. 28). On top of the bed-rock a sequence of successive and alternating layers of brown, grey and yellow clayish soils delineate the groundwork where the building was constructed (Fig. 29). Together with some stone retaining walls, the sequence of the compacted earth accumulation is part of the extensive work involved in levelling and terracing the ancient surface of the natural mound, which was probably irregular and with a different elevation. Part of this groundwork, at a lower level on the slope in comparison to the pavements of the building (+1130.69/99 metres above sea level), is the thick stone wall made of large granitic boulders that marks its southern limit (Figs 30-31) (preserved between +1119.17 asl and +1120.29 asl); the reddish compacted earthen floor south of the wall is +1127.82 asl, thus indicating a difference of about 3.15 m. The small portion of building exposed (Fig. 32) consists of a room and a corridor provided with clay, plastered and cobbled floors (Figs 33-34); below these, there is a series of beaten clayish floors which prepared, together with containing walls, the ground for the construction (Figs 35-39). The soil used to prepare the groundwork, probably part of a terracing system lying on top of the bed rocks and partially the remains of the earlier mound, comes from elsewhere. In fact at the base of both the south wall of boulders and the inner accumulation north of this, there are two strata, one reddish and compacted and one in yellow crushed stone, similar to the virgin soil in this part of the site, which indicate that the filling of clayish soils must have been deposited intentionally and is not part of the earlier sequence cut at the time Building III was erected. This is noteworthy because the filling of alternating layers of brown, grey and yellow clayish soils below the floors and foundations of Building III contains a large amount of sherds of Middle Bronze Age and Early Bronze Age/Middle Bronze Age transition that must have originally accumulated elsewhere (see Orsi, this contribution). This presence of a mixed repertoire of sherds, mainly of earlier dates, in relation to the fillings used in Hittite architecture has been already observed in Boğazköy (Hachmann 1957: 61).

Two building phases have been identified: the phase of construction and first use and a later reuse of some emerging structures in a subsequent period. The walls delimiting the room consisted of foundations made of stones and the upper part in mudbricks, eroded by the sloping ground. The masonry technique of the foundations is characterised by external faces built with a row of medium and small-sized stones without mortar and a core filled with debris and stones; fragmentary mud-bricks are visible on top of the foundations, some of them still in place. This kind of structure with external faces of foundation walls in relatively regular stones and the core filled with other materials, rubble and earth has been documented also in Maşat Höyük (Özgüç 1982: 74). Traces of severe fire have been registered on walls where traces of a layer of plaster are poorly preserved, in the filling of the corridor, consisting of burned red soil and among the materials used to build the core of the walls. The recent phase of use has been identified directly beneath the surface of the slope in the addition of two walls leaning against the thick southern retaining wall (Fig. 40). The evidence suggests a possible date within the Late Bronze Age for the construction of Building III and the Iron Age at the latest for the phase of reuse.

#### Area C

Area C, on the south-eastern slope of the mound, provided us with evidence concerning a composite structure which was adapted to the profile of the previous stratification and gave shape to the present mound (Mazzoni, D'Agostino 2015: 170-175). It is a huge rampart aimed at structurally reinforcing the slope and possibly also

functioning as part of a defensive system of the citadel (Figs 41-42). To summarise, in the articulated stratigraphic relations between the different elements composing this huge structure covering the slope from the base to the top, three main structural phases can be recognised but with several inner sub-phases: the accumulation of layers overlapping the natural bedrock, the building of the rampart and the work undertaken to maintain it.

In this part of the site, on top of the natural soil, a sequence of layers of clayish soil sloping from the centre of the ancient central mound represents the first evidence of anthropic activity (Figs 43-44). The layers containing sherds, a few small stones and a concentration of charcoal fragments in the matrix of the soil represent the surface of the ancient mound at the time of the construction of the rampart. The rampart consists of a sloping stone escarpment covering the lower part of the mound and a superstructure made from an accumulation of soils gridded in a trestle of thin, mud-brick walls. Medium-sized stones with a roughly flattened visible slanting face constitute the escarpment or *glacis*, largely covered by other, fallen stones (Fig. 45). The upper part of the rampart, the bulk of alternating burnt and ashy soils (Figs 46-50), lay directly on the sequence of clayish layers representing the first traces of accumulation in this part of the mound. The earth structure is contained by thin radial walls in fragmentary burned mud-bricks and small/medium sized stones following the incline of the underlying deposit and accumulation of burnt ashy soils and debris in between (Figs 51-53). These thin walls (two of which have been excavated, about 5 meters apart) are not freestanding and were probably erected at the same time as the soil accumulation was created. Burnt soils and debris accumulated here but probably also the fragmentary mud-bricks of the walls, built without mortar, derive from a different and older context, as suggested by the potsherds and fragments of Hittite cuneiform tablets, and represent the material traces of a fire in a building from which they had been removed. This method of accumulating soils and debris from older contexts and include them in the preparatory work for new structure, has been observed also in Area D, in relation to the groundwork of Building III. This is a normal procedure connected with the construction of large and complex structures that necessitate the erection of retaining walls, flattening and terracing the pre-existent irregularity of the mound and obtaining sufficiently large regular surfaces, especially in the case of summits of mounds of limited size, as ours seems to be. At this time the main concern was to enlarge and strengthen the area for construction on top of the mound and allow the creation of a new citadel.

Probably later, the upper part of this retaining structure was restored and maintained in use, with accumulations of earth of different quality and texture and the use of small sized stones for walls which rested upon the emerging rows of those in mud-brick, and were sometimes grafted onto them. These were connected to each other by small orthogonal walls so as to reinforce the surface against ground instability and erosion, almost terracing the slope (Figs 54-55). All these structures and the sequence of layers date to the Middle Iron Age, the later intervention possibly to the Late Iron Age. Stone *glacis* covering the slope of the mound, with the function of protecting against the erosions and strengthening the summit are documented in the area where Uşaklı is located (see D'Agostino Orsi 2015: 179, footnote 300; Mazzoni, this article). A similar structure dating between 7<sup>th</sup> and 6<sup>th</sup> centuries has been exposed also at Boğazköy, in Büyükkale, apparently imitating the Late Bronze age stone-paved *glacis* prototypes (Bittel 1970: 147-148 and plate 27b).

Fragments of wall lime plaster have been found within the layers of burnt ashy soils and debris that are part of the retaining structure exposed in Area C, the origin of which is supposed to be from an older context dating to the Late Bronze Age (Fig. 56). The four small pieces present a polychrome surface with red, black and whitish motifs and with imprints of wicker or vegetal trellis on the back, residuals of a possible wall painting or ornamental decoration of the lower face of the roof or walls. Similar evidence comes from temple and palatial contexts of the Upper city of Boğazköy (Neve 1999: 50 and taf. 31c; 2001: 29, 111 and taf. 48c; Özyar 2006: 131-132): characteristics of some fragments have been interpreted as evidence of an execution in fresco technique (Brysaert 2008: 114-115) whereas other aspects indicate that parts of the paintings were made in *secco* technique (von Rüdén, Jungfleisch 2017: 72-73).

In the superficial layers and among the materials used to build the *glacis*, many fragments of heavy pierced stone tools have been found (Fig. 57). These sort of hammers are made of hard stone, dark grey or green in colour (gabbro or granite/andesite) and present a rough surface, only a few specimens having a regular profile. The inner



surface of the central axial hole is polished and, in some cases, shows traces of drilling. Similar objects come from Boğazköy (Bohemer 1972: taf. LXXXIX-XC; Neve 1983: 450; Schachner 2010: res. 2, 3a-c) and Kuşaklı (Arnhold 2009: taf. 36, 5; Müller-Karpe 2017: 107, abb. 103).

### Area B

In Area B and in the western appendix of Area A (square J18 A1;) layers pertaining to the later periods of occupation have been exposed (Fig. 58). The masonry technique in rough stones and associated materials enabled us to relate the structures discovered in both squares, which are separated by a distance of roughly 10 meters, to the same chronological range. The sequence is currently divided into three phases in line with the results of the 2015 campaign. The early level was identified in area B, in a small section next to the eastern wall of the room, but the size of the sounding is very limited and thus prevents us from understanding the quality and type of the context (Fig. 59). The level precedes the construction of the wall. The other more recent level, consisting of two building phases, is documented through the construction of the rooms and some partial structural modifications concerning walls and the raising of floor levels (Fig. 60). The room and connected installations (a basin in plastered stones, small walls, floors and working areas) excavated during the last campaign relate to the large rectangular Building I identified through the geophysical survey (Mazzoni 2015: 8 and fig. 4). The room identified during the course of the 2014 campaign can be considered contemporary with this, but is probably part of a different building (Fig. 61-65). The filling of the rooms and outer spaces is characterised by soil and debris resulting from the collapse of the upper part of the walls as well as the remains of the roof (tiles).

### The summit of the high mound

Remarks concerning the later levels of occupation have to take into consideration also the anomalies registered during the geomagnetic prospection at the top of the höyük. Here an approximately circular black band has been interpreted as a possible fortification wall following the perimeter of the mound (Mazzoni, D'Agostino 2015: fig. 8-3) and delimiting an area of 0.5 hectares. The cleaning of a small portion of the wall emerging on the surface and part of the circuit, enabled us to observe the use of large boulders sandwiching layers of medium-sized stones (D'Agostino, Orsi 2015: 179 and plate 12). The evidence to date the structure is, at the moment, very scarce and consist of remarks about the masonry technique and some general considerations. The absence of mortar is a feature that distinguishes the building technique of the Uşaklı wall from the citadel wall of Çadır Höyük, for example, dating to the Byzantine period (Steadman et al. 2015: 106-107). At the same time the scarce presence of sherds dating to the later periods on the summit of the mound and along the slopes deprives us of a good argument in support of a later date. This does not, however, in any case represent final proof for excluding a Late Roman date considering the fact that the wall could have contained the scattering and slippage of the sherds in relation with the phase of use on the slope. However, in the central plateau the trend towards living on mounded sites, often fortified, is documented in the course of the Late Iron Age. Whatever the possible date of the circular wall, we must not exclude from any considerations the general similarity with the walled citadel on top of the central mound of Kuşaklı-Sarissa, characterised by a polygonal circuit with towers (Powroznik 2010: 83-104, plan 1-2 and 4). According to the elements currently available to us, the possible date ranges from the very end of the Late Iron Age to the Hellenistic/Roman period. Yet to be investigated is the relation between the Late Iron Age glais and this circular anomaly connected with the probable citadel wall in order to have a stratigraphic framework underpinning and forming a solid base of our speculations.

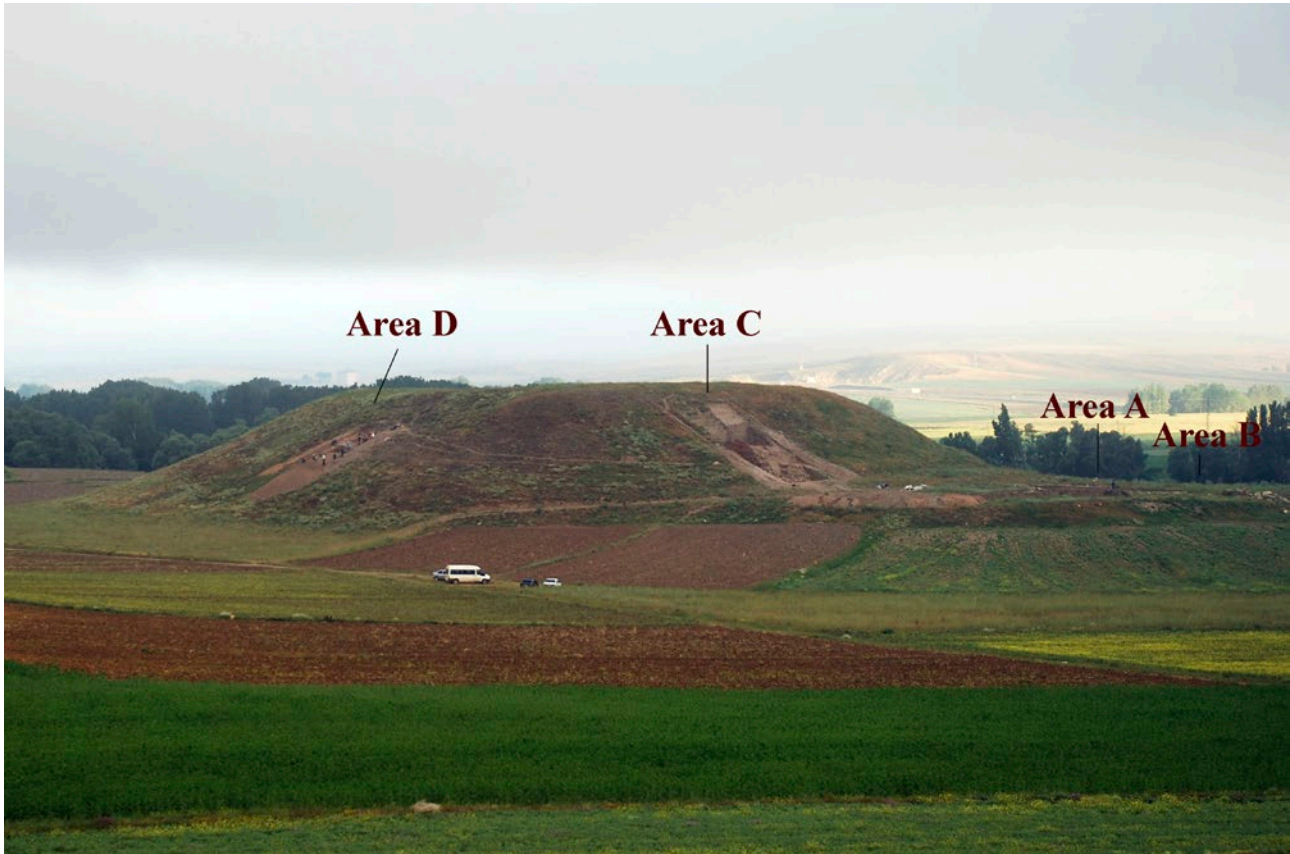

**Fig. 1:** The site of Uşaklı and the excavation areas. From south-east



**Fig. 2:** The first dig operation in Area A opened in 2013 (squares J19 C4 and J19 B4). The pictures a and b are taken from south-east, c and d from north and north-west



**Fig. 3:** The walls of the Building II exposed at the beginning of the 2013 season (room 126, squares J19 C4 and J19 B4)



**Fig. 4:** The southern squares of Area A, in 2015. From south-east



**Fig. 5:** The foundation wall 240 in southern squares. From north-west



**Fig. 7:** The current eastern limit of the Building II. On the left the medium sized stones of the under-foundation structure, below the large boulders. From north-west



**Fig. 6:** Foundation walls in the central squares of the Building II: at the centre the room 134. From north-west



**Fig. 8:** The north-western corner of room 127 (square J19 C4): the foundations composed by large boulders and layers of medium sized stones. From west



**Fig. 9:** The north-eastern corner of the Area A (squares I19 B3-4), with the layers of medium-sized stones and superimposed large boulders. From north-east



**Fig. 10:** The central area of the Building II (room 35, squares I19 B2-C2): portions of the under-foundations were probably removed during the phase of dismantling of the structures. The weight of the boulders caused a compression of the underlying layers of stones. From north-west



**Fig. 11:** One of the elongated spaces on the north-western corner of Area A (room 26, square I19 D1). The picture shows the stratigraphic relation between the under-foundations, the foundation walls, both visible in the sounding, and remains of a beaten earth floor. From north-east



**Fig. 12:** A detail of the foundation structures: the row of large boulder laying on three rows of middle-sized stones (room 127, square J19 C4). From east



**Fig. 13:** A detail of the foundation structures: here the rows of middle-sized stones under the boulders are four (room 127, square J19 C4). From west



**Fig. 14:** Displaced boulders (square I19 D2). From east



**Fig. 15:** Displaced boulders (square I19 D2), in the corner of the area, top left, the rows of small sized stones identify a phase of reuse of this part of Building II, to date probably to the later periods. From west



**Fig. 16:** Displaced boulders within one of the elongated room of the north west wing (room 75, squares J19 A1-2). From south-west



**Fig.17:** The area A at the end of the 2013 season of work. On the left, boulders and stones removed and piled up by the landowner to facilitate his ploughing activity, during the winter of 2012. Picture taken by drone (Kerkenes Project team)



**Fig. 18:** The western elongated room (squares I19 A1, D1) where traces of beaten earth floor have been exposed. From south-west

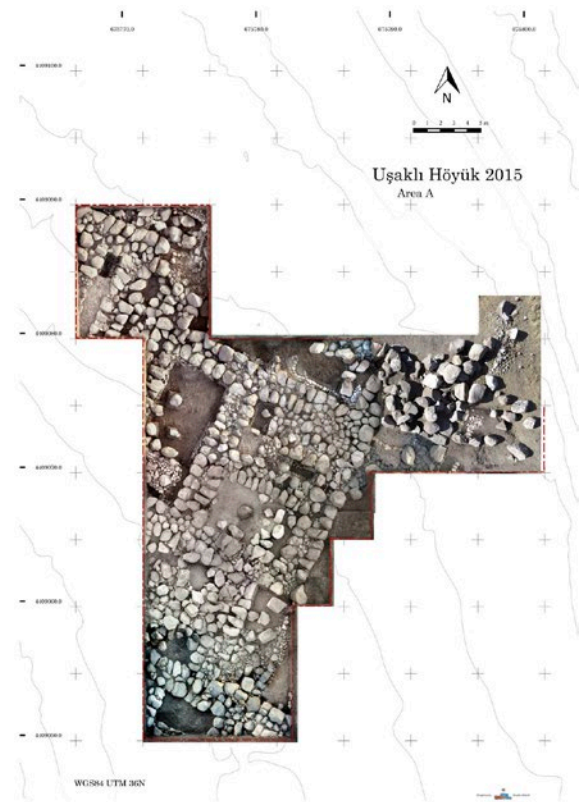

**Fig. 19:** The portion of Building II exposed between 2013 and 2015 campaigns. Orthoimage. composed by R. Trojanis



**Fig. 20:** Traces of the reuse of some portion of the Building II: here half-circle installation in stones (square J19 B3). From north



**Fig. 21:** A flimsy wall made by small and medium sized stones (wall 113, square J20 C1) leaning to the foundation wall 111 of Building II. From east



**Fig. 22:** Walls made by small sized stones on top of large boulders identify the reuse of some remains of Building II dating to later periods. From south-west

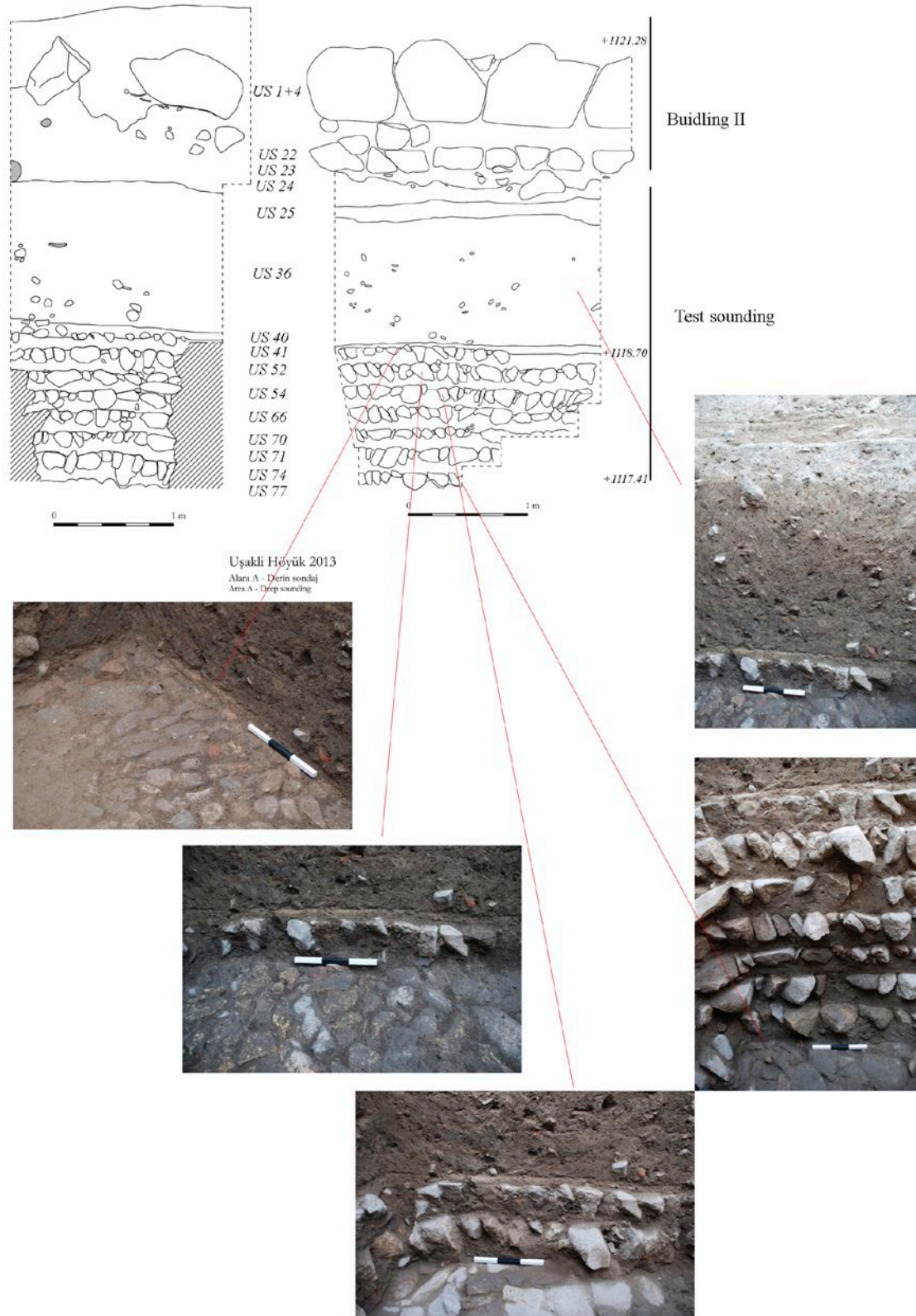

**Fig. 24:** The upper cobbled floor found in the deep sounding. Up, on the right stones and boulders of the Building II. From north-west



**Fig. 23:** 3D model of the structures exposed in 2013 with the location of the deep sounding in room 126, square J19 B4. From east (by G. Carpentiero)





**Fig. 25:** West and south sections of the deep sounding and some picture showing the sequence of cobbled floors below the platform of Building II



**Fig. 26:** Three miniature pots from the Building II, in relation to a fragmented floor and the stone foundations



**Fig. 27:** Two fragmentary crescent-shaped 'loom-weights' in clay, perforated at each end

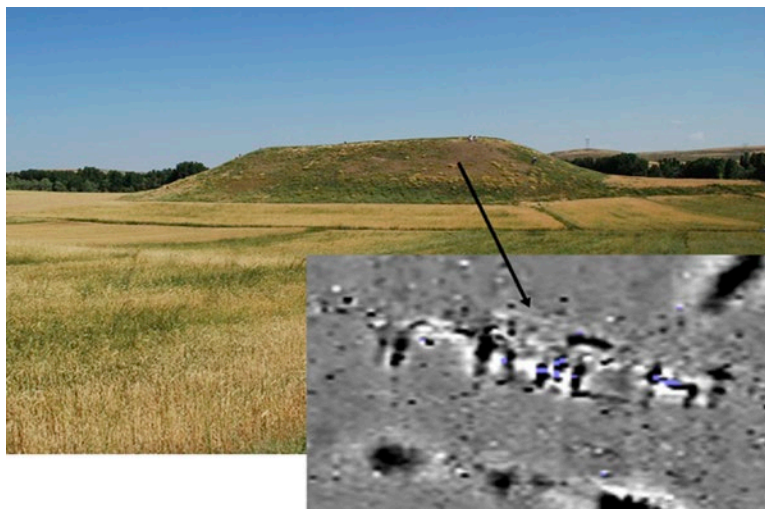

**Fig. 28:** The southern slope of the mound where Area D is located and the plot with the geomagnetic anomalies registered during the surface prospection



**Fig. 29:** The stratification of clayish layers of soils used as groundwork for the Building III, in the small sounding opened through the floors. From south



**Fig. 30:** The southern wall in granitic boulders of the Building III. From south



**Fig. 31:** The southern wall of Building III and the foundations of other walls. The reddish compacted layers visible on the left and at the base of the sounding on the right, represent the floor of the groundwork of which the wall itself and the accumulation of clayish soil are part. From south-east



**Fig. 32:** The Area D and the portion of Building III exposed at the end of the 2015 excavation season. From south



**Fig. 33:** On the left the cobbled floor leaning against a foundation wall of Building III (room 58). The fire of the building left traces also on the soil in contact with the stones of the foundations. From north



**Fig. 34:** At the centre of the picture two portions of the cobbled floor with different texture. On the right, remains of mud bricks on top of the stone foundation. In the background is the foundation of the western wall of room 58 and, on the left, the layer of clayish soils of the groundwork exposed by the erosion along the slope. From east



**Fig. 35:** The foundation walls of room 58 with traces of burned mud-bricks visible, at right. At the centre of the image one of the beaten clayish floor that are part of the groundwork of Building III. From north-east



**Fig. 36:** Foundation walls of Building III and, on the right, the corridor 59. The core of the wall contains stones, ash and fragmentary mud-bricks but burned during the fire



**Fig. 37:** Detail of the foundation wall laying on top of the boulders of the southern retaining wall 8. From east



**Fig. 38:** The cobbled floor 39, on the left of the foundation wall and the floor 27, burned and vitrified during the fire that destroyed the Building III (cut by a pit dating to the Iron Age). From north section



**Fig. 39:** Particular of the beaten clay floor 31 and the vitrified layer. From south-west



**Fig. 40:** The remains of small and middle sized walls lining against the southern retaining wall that identify a later reuse. From south-east



**Fig. 41:** Area C, the remains of the glacis and the grid of thin walls that reinforce the slope of the mound. At the centre of the image, one of the radial wall made by fired mud-bricks and stones part of the structure. From north-east



**Fig. 42:** Area C, some portions of the *glacis* in situ, exposed after the removal of the stones fallen from the upper part of the slope. From north-east



**Fig. 43:** The sounding behind the *glacis*, in Area C: the sequence with clayish grey layers, dating to the Middle Iron Age, on top of the natural rock and the accumulation of burned ashy grey and reddish soils on top of them that contains pottery sherds dating to the Late Bronze Age and a fragment of cuneiform tablet. From north-east



**Fig. 44:** The sounding behind the *glacis*, in Area C: The grey clayish layers on top of the natural rock and the accumulation of ashy grey and reddish soils at the base of the thin wall 31 in burned mud-bricks and stones. From south



**Fig. 45:** Some stones of the *glacis* in place, on the right, below the fallen stones. From east



**Fig. 46:** The accumulation of incoherent reddish and ashy soils between the radial walls of the structure retaining the south-eastern slope of the mound. A fox nest produced the holes visible in plan and in the sections. From east



**Fig. 47:** The accumulation of incoherent soils and the burned mud-bricks of the radial wall. The stone walls climbing the slope are part of the structure that cover this part of the mound. From south-east.



**Fig. 48:** A detail with the stone walls below the surface and the burned red mud-bricks of the wall 31. From south-east



**Fig. 49:** In the sections of Area C are visible the stratification of reddish and grey incoherent. At the base of them are the clay grey layers dating to the Middle Iron Age. From east



**Fig. 50:** The accumulation of incoherent layers of burned soil covered by other grey layers sloping down from the upper part of the mound. All these elements are part of the huge retaining system of the slope dating to the Iron Age. From east-north-east



**Fig. 51:** The accumulation of burned soil in course of removal at the end of 2014 season and the southern side of the wall in mud-bricks and stones. In order to reach the base of the wall a small sounding was opened in the last days of that campaign. From south-east



**Fig. 52:** The accumulation of burned and ashy soils in the compartment north of wall 31. The northern side of the wall 31 is visible on the left. From north-east





**Fig. 53:** A detail with the structure of the wall 31, with stones and fragmentary burned mud-bricks, without mortar. From south



**Fig. 54:** The grid of walls retaining the slope upstream of the *glacis*. The flimsy radial walls delimiting the compartments of the structure (respectively 12 and 45) are visible at the southern and northern edges of the square (in the upper part of the picture). Below the layers of grey soils and the stone walls at the centre of the picture appear the accumulation of reddish ashy soils. From east



**Fig. 55:** The stone walls on top of the *glacis* in course of excavations. At the bottom, on the left, a fragment of heavy green pierced stone, probably a 'hammer'. From north east



**Fig. 56:** Fragments of wall plaster



**Fig. 57:** Fragments of heavy pierced tools in hard stones from the slope of the Area C, in relation with the stone walls of the *glacis* and the upper retaining structure



**Fig. 58:** Location of the Area B, square J18 A1, at the bottom, where structure dating to the later period have been exposed; on the right the north-western wing of the Building II. From south-west



**Fig. 59:** Walls and installations of Area B. The area at the centre of the picture shows structures belonging to the early level here reached, preceding the construction of the room. The walls of the room and the plastered basin are contemporary. From south-east



**Fig. 60:** The room and the plastered basin exposed in Area B. From south-east



**Fig. 61:** The preparation of the square J18 A1 before the beginning of excavation in 2014 season. From south-west



**Fig. 62:** Square J18 A1: the emerging structure directly below the surface. From north-west



**Fig. 63:** Square J18 A1: the room 123 and remains of the walls partially collapsed. From north-west



**Fig. 64:** The room exposed in square square J18 A1 and the stone pavement 124. From south-west



**Fig. 65:** The room 123 and the opening at the bottom of the wall 102, probably a pipe to drain liquids. From north-west

### *Ceramics and materials*

Valentina Orsi

A preliminary assessment of the recovered materials (Charts 1-12) is given here aimed evaluating the various archaeological contexts brought to light in the different sectors of the site in terms of depositional processes, general chronology and, as far as possible, function. With respect to chronological aspects, evidence relating to the periods of use of the structures, as well as about the occupational sequences in the different areas of the site has been gathered. Concerning function, one of the main indicators is represented by the pottery assemblage, evaluated in its context of recovery. Post depositional events related to either ancient or modern times, however, played an important role in the formation process of the archaeological deposits of Uşaklı Höyük. This phenomenon, which is rather common in Central Anatolian sites, required a particularly accurate analysis of the combined evidence of stratigraphy and materials.

Potsherds constituted the most common find category. In most cases, they were not recovered from their last context of use nor, apparently, from their first place of discard. In fact, different series of post depositional events appeared to be substantial in most of the areas of the site. Other common find categories include combusted, melted slags and roof tiles.

**Diagram 1:** Distribution of finds per excavation area<sup>1</sup>

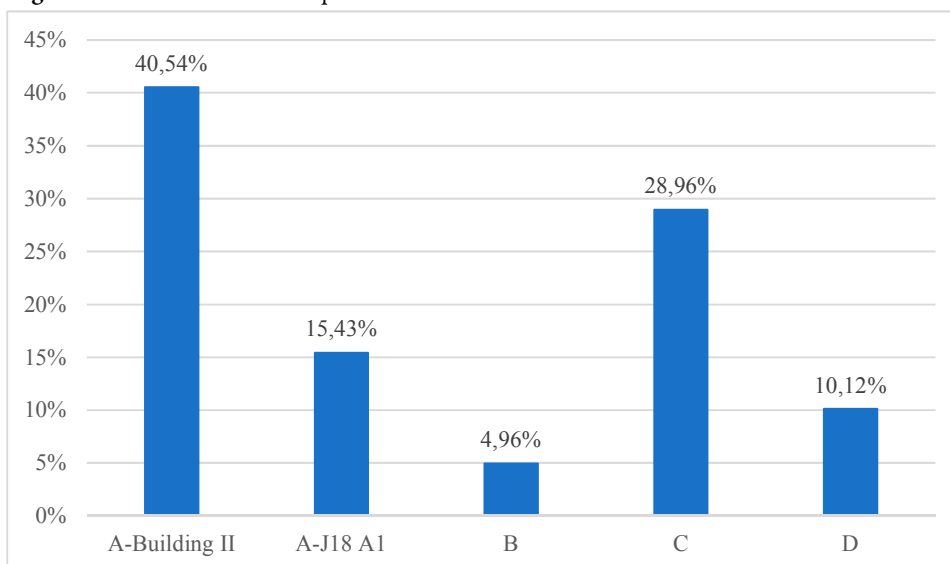

Most of the materials derived from the Area A-Building II, which was the largest excavation area, followed by the Area C step trench. The relatively high percentages of materials deriving from the small Area A-J18 A1 (5x5m), reflect the large incidence of roof-tile fragments recovered in the sector, to be attributed to the late periods.

The slags largely derive from the combustion and melting of clayish artefacts (chiefly pottery, bricks or architectural and structural components), but samples of melted stones have been also recognized.

Structures severely effected by fire were uncovered primarily in the Area D, belonging to the Late Bronze Age Building III, but the concentration of combusted slags in that area is relatively low. A major concentration, in fact, is registered in the Areas C and A (Diagram 2).

<sup>1</sup> Percentage of finds per excavation area on the total amount of finds 2013-2015. The total amount of finds is preliminarily estimated as up to 867.75 Kg.

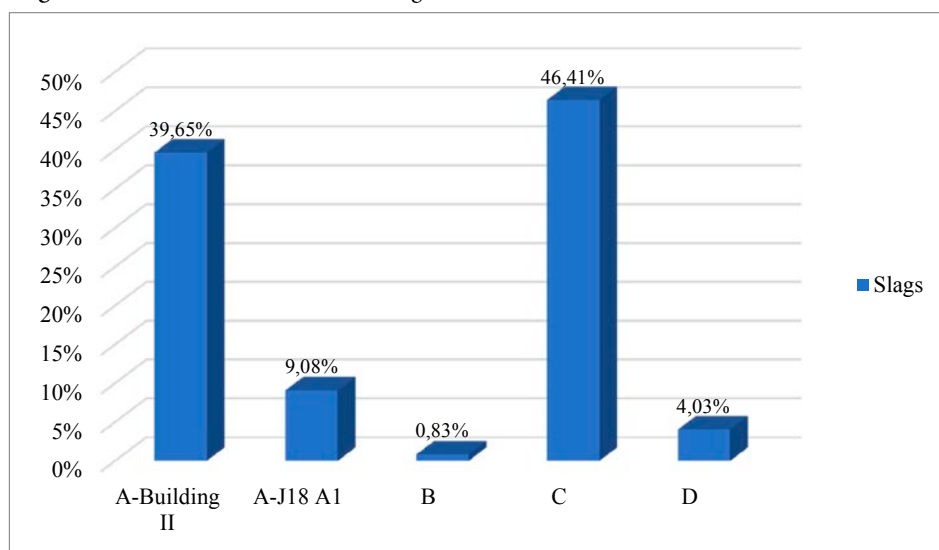
**Diagram 2:** Distribution of combusted slags in the different sectors of excavation<sup>2</sup>

The building activities recorded in Area C are to be entirely attributed to the Iron Age period, but fragmentary burned mud-bricks were reused from some earlier context in the construction of the thin, radial walls on the slope, and layers of burnt and ashy soils containing Late Bronze Age pottery were largely employed in the fillings. The combusted slags in Area C being mainly related to the burnt fillings, they could presumably derive from the same Late Bronze Age burnt context that originated the pottery and, maybe, the burned mud-bricks of the radial walls.

No trace of burnt layers, instead, was uncovered in the Area A, where most of the combusted slags derived from the superficial, mixed fillings.

Therefore, with the exception of a few stratigraphic units from the Area D-Building III, the vast majority of combusted slags was not recovered from primary contexts. Their distribution in the different sectors of excavation, in fact, reflects post-depositional events which took place in the Middle Iron Age in the case of the Area C, and, in the case of the Area A, during the long span of time in which the area of Late Bronze Age-Building II was frequented after the building had lost its primary function.

It was hypothesised that the combusted slags, which constituted one of the registered find categories also during the surface survey, were related to fire events or, less likely, to kiln activities (Mazzoni, D'Agostino, Orsi 2010: 123). Considering the probable chronological range of the heavily burnt structures recovered in the Area D (Building III), as well as of the burnt earth layers accumulated in the Area C, most of the combusted slags recovered on the site seem likely to be related to fire events dating back to the Late Bronze Age.<sup>3</sup>

With regard to roof tiles, even though belonging in principle to the category of building materials, such as bricks or building stones, which were not numbered or weighed, they received more attention by virtue of their chronological significance, which links them to the later periods of occupation on the site. The analysis of their scattering on the surface was of great help in evaluating the representativeness of the different chronological periods in the areas of the site during the preliminary surface survey (D'Agostino, Orsi 2015: 182, 184; Mazzoni, D'Agostino, Orsi 2010: 123). To the same end, their registration was aimed at evaluating the eventuality of later phases of occupation or heavy post-depositional disturbances in the earlier levels.

<sup>2</sup> Distribution of combusted slags per excavation area on the total amount of combusted slags recovered during the excavations 2013-2015. The total amount of combusted slags is preliminarily estimated as up to 15.84 Kg (see Chart 1).

<sup>3</sup> It is worth nothing that also the fragmentary tablet UK09.E.2 (Mazzoni, Pecchioli Daddi 2015: 419, pl. 43), which is the largest fragment of cuneiform tablet found so far, was severely combusted, one of its sides being deformed by fire. The fragmentary tablet, dating to the Late Bronze Age, was found on the southern slope of the lower terrace (Archi et al. 2015: fig. 1).

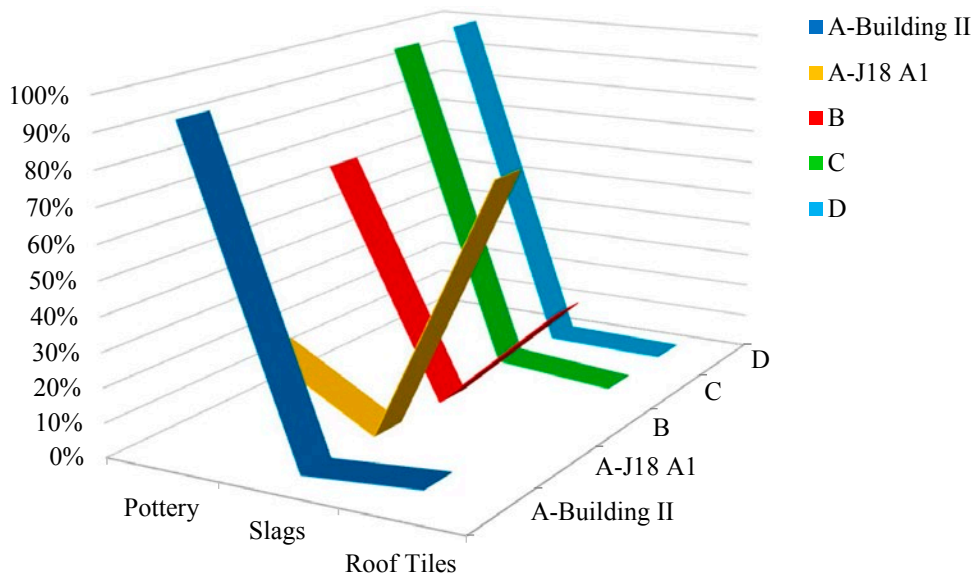
**Diagram 3:** Overview of the finds inventory in the different excavation areas<sup>4</sup>

Excavation Areas (U13-U15)	Pottery	Combusted Slags	Roof Tiles	Total
Area A-Building II	328,63Kg 93,43%	6.280 Kg 1,79%	16.84 Kg 4,79%	351,75Kg 100.00%
Area A-J18 A1	27.37 Kg 20.44%	1.438 Kg 1.07%	105.080 Kg 78.49%	133.89 Kg 100.00%
Area B	28.93 Kg 67.23%	0.131 Kg 0.30%	13.971 Kg 32.47%	43.03 Kg 100.00%
Area C	243.76 Kg 97.00%	7.350 Kg 2.92%	0.190 Kg 0.08%	251.30 Kg 100.00%
Area D	87.14 Kg 99.27%	0.638 Kg 0.73%		87.78 Kg 100.00%

A comparison of the average composition of the finds inventory in the different excavation areas of the site is represented in Diagram 3. Two clusters are evident: while the composition of the finds inventory from Area A-Building II, Area C and Area D is rather similar (cluster 1), characterized by very high percentages of pottery, and only a minimal ratio of combusted slags and roof-tiles, Area B and Area A-square J18 A1 (cluster 2) furnished a different prospectation, characterized by a high incidence of roof-tiles. The two clusters mirror a chronological significance. To the second group belong the excavation contexts where the latest levels have been recovered, while to the first group belong the excavation contexts which revealed more ancient occupational levels.

<sup>4</sup> Percentages are calculated on the total weight of finds per excavation area. For each area, the total is calculated on the weights of main finds categories. Within these, the commonest at Uşaklı are considered: pottery, roof tiles and combusted slags. Since each group is characterised by a significantly different range of weight, the graph is not useful for comparing the ratio of each finds category in relation to the others. Instead it may give an immediate overview of similarities and dissimilarities in the composition of the finds inventory in the different excavation areas.

### The Pottery

Between 2013 and 2015, a total of 22413 potsherds were recovered for a total weight of 716 Kg ca. (Charts 1-2). On the base of preliminary classification, 5384 potsherds have been sorted as diagnostic samples, while 17029, mainly coinciding with plain body-sherds, have been categorised as generic.<sup>5</sup>

**Chart 1:** Uşaklı Höyük 2013-2015. Overview of the materials recovered in the different excavation Areas

Year	Area	Diagnostic Potsherds (Number)	Generic Potsherds (Number)	Potsherds Total (Number)	Slags (Weight in Kg)	Roof Tiles (Weight in Kg)
2013-2015	A - Building II	2052	8175	10227	6.280	16.84
2014	A - J18 A1	149	620	769	1.438	105.080
2015	B	240	775	1015	0.131	13.971
2014-2015	C	2014	5004	7018	7.350	0.190
2015	D	929	2455	3384	0.638	
<b>2013-2015</b>	<b>Total</b>	<b>5384</b>	<b>17029</b>	<b>22413</b>	<b>15.837</b>	<b>136.084</b>

**Chart 2:** Uşaklı Höyük 2013-2015. Qualification of potsherds recovered in the different excavation Areas

Year	Area	Common Ware (Weight in Kg)	Storage Ware (Weight in Kg)	Kitchen Ware (Weight in Kg)	Fine Ware (Weight in Kg)	Pottery Total (Weight in Kg)
2013-2015	A - Building II	210.74	54.55	63.02	0.36	328.63
2014	A - J18 A1	12.36	11.91	3.03	0.07	27.37
2014-2015	C	194.75	19.78	28.35	0.88	28.93
2015	B	25.20	1.16	2.28	0.29	243.76
2015	D	67.37	7.04	12.32	0.407	87.14
<b>2013-2015</b>	<b>Total</b>	<b>510.41</b>	<b>94.45</b>	<b>109.01</b>	<b>1.99</b>	<b>715.83</b>

Macroscopic classification of the vessel's intended use (based on thickness, shape, technological attributes) gave some clues about the possible functional destination of the different sectors of the site throughout the occupational sequence.

Diagram 4 represents a comparison of the composition of the ceramic inventory in the different excavation areas in relation to the main functional ceramic categories. At this stage of the analysis, very generic functional categories have been determined, and include: common ware, storage ware, kitchen/cooking ware, and fine ware.<sup>6</sup> While the ceramic inventories of sector J18 A1 in Area A and, to a lesser extent, the ceramic inventory of Area B are probably the result of a relatively circumscribed series of depositional events, it is worth noting that the ceramic inventories from Area A-Building II and Areas C and D, instead, reflect a long and complex series of depositional events.<sup>7</sup> Nevertheless, some macroscopic feature is detectable.

<sup>5</sup> For a detailed definition of the two groupings of diagnostic and generic potsherds see D'Agostino, Orsi 2015: 42.

<sup>6</sup> For a detailed description and definition of this classification see D'Agostino, Orsi 2015: 43.

<sup>7</sup> The excavation in these areas, in fact, revealed a plurality of activities connected with distinct chronological spans and, moreover, the potsherds were not recovered in their primary context of use. The ceramic inventory, of which Diagram 4 gives an overall overview, does not, therefore, reflect a single phase of occupation but a long series of events. As far as the comparison is concerned, the incidence of a specific class in an inventory is not exactly comparable to the incidence of a different class in the same inventory, while it is perfectly comparable with the incidence of the same class in the ceramic inventory of a different excavation area. The different func-

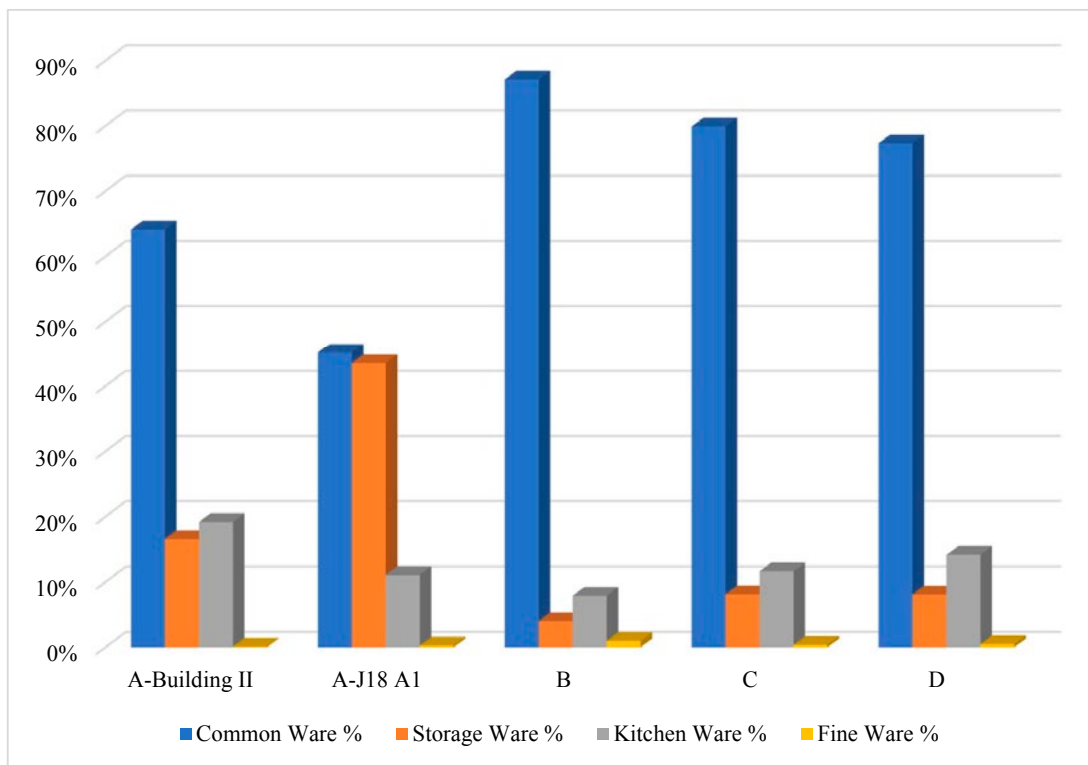
**Diagram 4.** The ceramic inventory of the different excavation areas: preliminary overview.

The common ware, which reflects the largest spectrum of activity, is by far the most frequent functional class of pottery. In this respect, an evident anomaly is represented by the ceramic inventory of Area A-sector J18 A1, where the high incidence of storage ware may reflect an effective functional characterization of the structure uncovered in the area. The inventory of Area A-Building II also slightly diverges from that of areas B, C and D, suggesting the possibility that events connected with storage or cooking activities, over time, played a more substantial role in these sectors than in the others.<sup>8</sup>

As observed elsewhere (Orsi 2018), in consequence of the marked continuity observed in Anatolian ceramic productions and particularly in the Hittite period, quantitative and statistical approaches in ceramic analysis provided more reliable results than qualitative approaches for investigating chronological issues (see Schoop 2006; Schoop 2009: 147; Mielke 2010). An experimental assessment of the possible chronological range of attribution of the ceramic assemblages from the various stratigraphic units, however, has been attempted based on ceramic comparisons.<sup>9</sup>

---

tional classes, in fact, may have considerably dissimilar average weight. Due to the lack of any whole or reconstructable vessel, sherd weight data were not converted into individual vessel estimates, while other procedures to achieve comparable sets of data between different categories (see Rice 1987: 291-293) have not been considered profitable at this stage of the analysis.

<sup>8</sup> For a more precise definition of the functional connotation of the area's ceramic inventory in the different chronological phase, more detailed analysis is in progress.

<sup>9</sup> For an overview on the state of the art with reference to the main sites of comparisons, see D'Agostino, Orsi 2015: 166-180 and Orsi 2018, note 14.



### Area A

The ceramic inventory from the superficial layers of Area A-Building II (Chart 2), is largely mixed. It includes, in fact, ceramic potsherds related to different chronological horizons, attesting to intense post-depositional events.

The large inventory of Late Bronze Age pottery types found in the fillings of the structure, considered in association with its building techniques, size and plan (Mazzoni, D'Agostino 2015: 166; D'Agostino, Orsi 2016: 341), points to the Hittite period as the phase of first and primary use of the building. Additional evidence for this date derives from the ceramic inventory from the deep sounding in the north-eastern sector of the building (square J19-B4) (Orsi 2018).

No materials have been retrieved *in situ*. The set of 3 miniature vessels (Fig. 26), which were recovered in the accumulation layers connected with the building phase belong, however, to cultic pottery equipment of the Late Bronze Age period, providing additional support for the general functional interpretation of the original structure.

The inventory includes principally common and kitchen wares, but a limited quantity of storage ware is also attested. Ceramic types which can be related to the so-called 'drab ware' ceramic production are quite frequent,<sup>10</sup> especially in the shape of simple bowls with plain or slightly in-turned rim and of medium-size jars (Fig. 66). Notable is the presence of the coarse platters, frequently bearing string impressions on the rim, and of large plates with thickened, banded rim (Fig. 67), whose dates range from almost the Old Hittite up to the Empire period.<sup>11</sup>

Red slip ware wheelmade examples,<sup>12</sup> whose apex in terms of quality and quantity is attributed to the Assyrian colony period (1<sup>st</sup> quarter of the 2<sup>nd</sup> millennium BC) and to the early part of the Hittite ceramic sequence (17<sup>th</sup> and beginning 16<sup>th</sup> century BC),<sup>13</sup> are also abundant. They are characterised by a marked variability both in the texture and the quality of the surface finish, which may be the result of a rather long chronological span,<sup>14</sup> while more consistency is visible in the morphological ranges (Fig. 68). Most of the attested variants, like bowls with in-turned upper sections, sometimes showing preserved or partially preserved triangular lugs (Fig. 68, second line), pitchers and spouted vessels, belong to ceramic types bearing a marked continuity in north-central Anatolia from the Assyrian colony period into the early and intermediate stages of the Hittite ceramic sequences (Schoop 2009: 150-151).<sup>15</sup> Curved or carinated bowls where the red slip is limited to a band on the mouth, which are considered a later evolution (14<sup>th</sup>-13<sup>th</sup> cent. BC),<sup>16</sup> are also well attested.

Also significant is the inventory of ceramics from later periods, likely to be related to sparse, secondary use of the area (Figs. 69-71). These include middle and late Iron Age examples, which consist primarily of painted and

<sup>10</sup> The definition of drab ware is largely used in archaeological literature with reference to the predominant fabric type in the ceramic assemblages of the Hittite period in the northern part of Central Anatolia. According to W.-D. Schoop (2011: 242), it is typical of any 'Hittite pottery inventory' found from the beginning of the *karum* period until the end of the Late Bronze Age period. It is wheelmade, unslipped and with a roughly smoothed surface (Schoop 2011: 242). See also Mielke 2017: 130, with specific reference to note 42. As far as the Uşaklı Höyük ceramic inventory is concerned, this term was mainly used in reference to a specific set of ceramic types (D'Agostino, Orsi 2015: 61-64).

<sup>11</sup> As a reference see D'Agostino, Orsi 2015: 170, types 1A-H.

<sup>12</sup> For a detailed characterization of the ware, see D'Agostino, Orsi 2015: 83-91.

<sup>13</sup> Here reference is made to the general subdivision of the Hittite ceramic sequence into three parts as proposed by W.-D. Schoop (2011: 242-243). According to this scheme, the 'early' stage of the Hittite ceramic sequence may be roughly equated with the 17<sup>th</sup> and the beginning of the 16<sup>th</sup> centuries; the 'middle' stage with the 16<sup>th</sup> and 15<sup>th</sup> centuries, and the 'late' stage with 14<sup>th</sup> and 13<sup>th</sup> centuries BC (Schoop 2011: 242). Further local periodization schemes, however, resulted from the analysis of the archaeological sequences at specific sites. Within the ceramic sequence of Kuşaklı/Sarissa West Slope, as example, an 'early' *Westhang* ceramic horizon corresponds to the second half/late 16<sup>th</sup> century BC; a 'middle' ceramic horizon corresponds to the 15<sup>th</sup> and 14<sup>th</sup> cent. BC, and a 'late' ceramic horizon corresponds to the 13<sup>th</sup> cent. BC (Mielke 2006: 170).

<sup>14</sup> Note, however, that a high degree of variability is also recognised as a peculiarity of the red-coated vessels in North-central Anatolia (Schoop 2011: 243).

<sup>15</sup> The wheelmade red slip ware morphologies of the Assyrian colony and Old Hittite period, in addition, find their older predecessor in the handmade red slip ware production of the late Early Bronze Age stages (Schoop 2009: 148-150).

<sup>16</sup> See Schoop 2009: 151 and fig. 13: 7-8; Schoop 2003a: 15 and fig. 19: 4; Schoop 2011: 260 and fig. 1: 3.

burnished ceramics, and of ceramics from later periods, which comprise, in particular, very fine ware samples with orange slipped surface.<sup>17</sup> The same type of fine ware is more widely attested in the Area B-Building I (Fig. 116) and from excavations in the square J18A1, on the western appendix of Area A.

Variable amounts of handmade sherds dating to the end of the 3<sup>rd</sup>-beginning of the 2<sup>nd</sup> millennium BC, with red slip or painted surface, are found scattered in most of the fillings (Figs 72-74). Their relatively high frequency in these contexts of later date might be connected with fairly extended post-depositional events that disturbed their primary context of deposition. These disturbing post-depositional events might be related, in first instance, to the construction of the large Building II. One would be tempted to hypothesize the primary contexts of deposition of these ceramics to have been located in its close vicinity, if not in the same area but, as observed in different contexts, relocation of soil over larger distance cannot be excluded.<sup>18</sup>

As far as chronological aspects are concerned, of great interest is the ceramic *corpus* from the test sounding excavated in room 126 (square J19-B4), in the north-eastern sector of Building II (Mazzoni, D'Agostino 2015: 167-169; D'Agostino, Orsi 2016: 345; Orsi 2018). Indeed, being related to a well sealed archaeological context, it offers a sound reference *post-quem* for the construction of the structure.

The sounding brought to light a series of eight cobbled floors separated by relatively thin earth layers. While the interpretation of the context as a result of subsequent planking levels, each in use at different times, appears unlikely, the quality of the archaeological sequence seems to point to a single set of operations related to the leveling and strengthening of the ground in view of the construction of Building II. The ceramic assemblages of the different stratigraphic units of the sounding are largely mixed, including types characteristic of distinct chronological horizons and of different primary contexts.

Handmade pottery types mainly with red slipped or painted surface (D'Agostino, Orsi 2015: 93-96), typical of the 3<sup>rd</sup>-beginning of the 2<sup>nd</sup> millennium BC, as for related typologies found in the superficial layers of Area A, must be considered intrusive, and testify to disturbing post-depositional events already occurred at the time of the construction of the Building II.<sup>19</sup> The ceramic inventory from the sounding, however, is, for the most part, composed of typical Late Bronze Age typologies (Figs. 75-83).

Quite abundant are coarse, large plates with banded rim (Figs. 75-78), which are considered one of the most characteristic Hittite ceramic products (Mielke 2006: 134; Glatz 2009: 130), and plain ware open shapes. Most common morphologies belong to small or medium sized curved bowls with slightly inturned or inside thickened rim, thus engendering a sort of anti-splash device. Other attested morphologies include deep vessels with outside thickened rims; deep vessels with funnel shaped or straight sides neck and high necked jars with thickened or everted rim. The red slip wheelmade ware (Fig. 82), which is found in association to shapes widespread since the Assyrian Colony period and into the first part of the Hittite ceramic sequence (Schoop 2009: 150-151; Schoop 2011: 245), is also well attested, while only sporadic, instead, are the white slip ware sherds (Fig. 83).

Although the marked continuity in the ceramic production registered so far at Hittite sites hampers the usefulness of the pottery as a dating tool in the Late Bronze Age central Anatolian sites,<sup>20</sup> the preliminary evaluation of the ceramic inventory from the test sounding may, all the same, give some hints for the dating of the construction of the Area A building II, which is likely to be located between the 15<sup>th</sup> and 14<sup>th</sup> century BC (Orsi, 2018).

<sup>17</sup> Or *Orange Slip Ware* in Uşaklı Höyük ceramic registration code, for which see D'Agostino, Orsi 2015: 68-69.

<sup>18</sup> In fact, this is the impression gathered so far from the excavations in Area C, where a large amount of earth seems to have been brought from elsewhere and, presumably, from Area D.

<sup>19</sup> Such disturbing events, in fact, may either have taken place during the very phase of construction of the large Building II, or be related to earlier activities.

<sup>20</sup> At this regard, see in particular Schoop 2008: 44-51.

**Chart 3:** Uşaklı Höyük 2013-2015. Materials recovered in Area A-Building II

Year	Area	Square	Stratigraphic Unit	Diagnostic Potsherds (Number)	Generic Potsherds (Number)	Potsherds Total (Number)	Slags (Weight in Kg)	Roof Tiles (Weight in Kg)
2014	A	J20 C1-3 - J20 B1 -J19 D4 - J20 D1 -K19 A3-4 - J19 A3-4	S	8	12	20	0.057	0.37
2014	A	J20 C1-3 - J20 B1 -J19 D4 - J20 D1 -K19 A3-4 - J19 A3-4	S	27	46	73	0.057	
2014	A	J20 C1-3 - J20 B1 -J19 D4 - J20 D1 -K19 A3-4 - J19 A3-4	S	59	183	242	0.007	0.76
2014	A	J20 C1-3 - J20 B1 -J19 D4 - J20 D1 -K19 A3-4 - J19 A3-4	S	34	83	117	0.320	2.42
2014	A	J20 C1-3 - J20 B1 -J19 D4 - J20 D1 -K19 A3-4 - J19 A3-4	S	21	136	157		1.74
2014	A	J20 C1-3 - J20 B1 -J19 D4 - J20 D1 -K19 A3-4 - J19 A3-4	S	2	2	4		0.15
2014	A	J20 C1-3 - J20 B1 -J19 D4 - J20 D1 -K19 A3-4 - J19 A3-4	S	16	14	30		
2014	A	J19 D4 - J20 D1 - K19 A3-4	3	137	342	479	2.461	4.22
2013	A	J19 D4 - J20 D1 - K19 A3-4	3	4	6	10		
2014	A	J19 B4	5	7	33	40		
2013	A	J19 C4	5	13	42	55	0.026	
2013	A	J19 C4	7	2	7	9		
2014	A	J20 B-C1	9	50	164	214	0.116	2.37
2013	A	J19 B4	10	18	50	68	0.003	0.54
2014	A	J20 B1	10	58	231	289		0.54
2013	A	J19 B4	11	24	89	113		0.33
2013	A	J19 A1 - I19 D1	12	81	745	826	0.204	
2013	A	I19 D1	13	43	195	238		0.30
2013	A	I19 D1	14	7	21	28	0.665	0.19
2013	A	J19 B4	15	25	101	126		1.63
2013	A	J19 B4	16	13	44	57		
2013	A	J19 B4	17	20	92	112		
2013	A	J19 B4	18	47	194	241		
2013	A	J19 B4	23	31	75	106		
2013	A	J19 B4	25	173	549	722		
2013	A	J19 B4	25	9	47	56		
2013	A	J19 A1-2	28	31	97	128	0.039	
2013	A	I19 D1	30	33	160	193	0.037	
2013	A	J19 B3	31	13	90	103		
2013	A	J19 B4	36	31	122	153		
2013	A	J19 C3	37	42	168	210	0.014	
2013	A	I19 D1	38	27	163	190		
2013	A	J19 B4	40	2	5	7		
2013	A	J19 B4	41	8	41	49		
2013	A	J19 B4	44	16	70	86		
2013	A	J19 B4	52	2	32	34	0.006	
2013	A	J19 B4	53	19	77	96		
2013	A	J19 B4	54	1	15	16		
2013	A	J19 B3	55	5	23	28	0.186	
2013	A	J19 B3	60	5	31	36		
2013	A	J19 B4	61	11	62	73		
2013	A	J19 B3	63	12	42	54		

Year	Area	Square	Stratigraphic Unit	Diagnostic Potsherds (Number)	Generic Potsherds (Number)	Potsherds Total (Number)	Slags (Weight in Kg)	Roof Tiles (Weight in Kg)
2013	A	J19 B-C2	65	232	963	1195	0.590	0.09
2013	A	J19 B4	66	5	13	18		
2013	A	J19 B4	69	8	58	66		
2013	A	J19 B4	70	1	6	7		
2013	A	J19 B4	71	7	27	34		
2013	A	J19 B4	73	7	19	26		
2013	A	J19 B4	74	3	9	12		
2013	A	J19 B4	76	7	19	26		
2013	A	J19 B-C2	78	312	1377	1689	0.041	
2013	A	J19 A2	79	6	16	22	0.005	
2013	A	I19 D2	82	12	36	48		
2013	A	J19 A2	83	5	19	24	0.001	
2014	A	J20 C1-2	104	10	7	17		
2014	A	J20 C2	105	3	5	8		
2014	A	J20 C1	110	14	30	44	0.037	
2014	A	J20 C1	113	3	4	7		
2014	A	J20 C1	114	11	25	36	0.049	0.17
2014	A	J20 C1-2	119	32	104	136	0.009	
2014	A	J20 C1	120	63	475	538	0.098	
2014	A	J20 C2-3	136	10	42	52	0.066	
2014	A	J20 C-D1	140		7	7	0.800	
2014	A	J20 C2-3	142	4	12	16		
2015	A	K19 B2	146	9	14	23		
2015	A	K19 A2	147	20	60	80		0.15
2015	A	K19 B-C3-4	150	32	50	82	0.236	0.87
2015	A	K19 C1	151	8	21	29	0.150	
2015	A	K19 C2-3	152	10	7	17		
2015	A	K19 D2	159	31	49	80		

**Chart 4:** Uşaklı Höyük 2013-2015. Qualification of potsherds recovered in Area A-Building II

Year	Area	Square	Stratigraphic Unit	Common Ware (Weight in Kg)	Storage Ware (Weight in Kg)	Kitchen Ware (Weight in Kg)	Fine Ware (Weight in Kg)	Ceramic Total (Weight in Kg)
2014	A	J20 C1-3 - J20 B1 -J19 D4 - J20 D1 -K19 A3-4 - J19 A3-4	S	0.64	0.37	0.14		1.15
2014	A	J20 C1-3 - J20 B1 -J19 D4 - J20 D1 -K19 A3-4 - J19 A3-4	S	3.01	1.11	0.33		4.45
2014	A	J20 C1-3 - J20 B1 -J19 D4 - J20 D1 -K19 A3-4 - J19 A3-4	S	5.41	2.09	0.94	0.01	8.45
2014	A	J20 C1-3 - J20 B1 -J19 D4 - J20 D1 -K19 A3-4 - J19 A3-4	S	3.53	0.71	1.94		6.19
2014	A	J20 C1-3 - J20 B1 -J19 D4 - J20 D1 -K19 A3-4 - J19 A3-4	S	2.95	3.46	1.68		8.09
2014	A	J20 C1-3 - J20 B1 -J19 D4 - J20 D1 -K19 A3-4 - J19 A3-4	S	0.17	0.20	0.01		0.37
2014	A	J20 C1-3 - J20 B1 -J19 D4 - J20 D1 -K19 A3-4 - J19 A3-4	S	1.11	0.35	0.05		1.51
2014	A	J19 D4 - J20 D1 - K19 A3-4	3	12.09	4.95	2.78	0.02	19.84
2013	A	J19 C4	3	0.34				0.34
2014	A	J19 B4	5	0.76	0.00	0.21		0.96
2013	A	J19 C4	5	2.02	0.41	0.27	0.035	2.73
2013	A	J19 C4	7	0.10		0.14		0.24
2014	A	J20 B-C1	9	4.67	1.62	0.90		7.19
2013	A	J19 B4	10	1.94	1.01	0.26	0.000	3.21
2014	A	J20 B1	10	5.51	1.43	1.62	0.05	8.61
2013	A	J19 B4	11	3.79	1.10	0.61	0.012	5.51
2013	A	J19 A1 - I19 D1	12	14.93	3.96	4.50	0.118	23.51
2013	A	I19 D1	13	7.06	1.14	2.28		10.47
2013	A	I19 D1	14	0.75		0.28		1.03
2013	A	J19 B4	15	3.12	0.97	1.03		5.12
2013	A	J19 B4	16	1.16	1.20	0.56	0.008	2.92
2013	A	J19 B4	17	1.92	0.37	1.37		3.66
2013	A	J19 B4	18	3.72	1.27	1.89		6.88
2013	A	J19 B4	23	1.99	0.13	0.27	0.010	2.40
2013	A	J19 B4	25	11.50	3.68	3.17	0.012	18.35
2013	A	J19 B4	25	0.70		0.25		0.95
2013	A	J19 A1-2	28	3.82	0.70	1.03		5.55
2013	A	I19 D1	30	4.93	1.84	1.45		8.21
2013	A	J19 B3	31	2.46	0.36	0.77		3.60
2013	A	J19 B4	36	3.36	0.30	1.16		4.82
2013	A	J19 C3	37	5.41	0.42	1.24		7.07
2013	A	I19 D1	38	4.07	0.88	1.04	0.010	6.01
2013	A	J19 B4	40	0.09				0.09
2013	A	J19 B4	41	0.45		0.26	0,001	0,71
2013	A	J19 B4	44	1,35	0,07	0,07	0,014	1,49
2013	A	J19 B4	52	0,63		0,07		0,70
2013	A	J19 B4	53	1,21	0,39	0,47	0,008	2,07
2013	A	J19 B4	54	0,36			0,003	0,36
2013	A	J19 B3	55	0,61	0,26	0,04		0,91
2013	A	J19 B3	60	0,75		0,50		1,24
2013	A	J19 B4	61	1,37		0,10		1,46
2013	A	J19 B3	63	1,33		0,44		1,77
2013	A	J19 B-C2	65	19,98	7,22	8,04		35,26

Year	Area	Square	Stratigraphic Unit	Common Ware (Weight in Kg)	Storage Ware (Weight in Kg)	Kitchen Ware (Weight in Kg)	Fine Ware (Weight in Kg)	Ceramic Total (Weight in Kg)
2013	A	J19 B4	66	0.19	0.19	0.30		0,69
2013	A	J19 B4	69	1.03	0.35	0.23	0.012	1,61
2013	A	J19 B4	70	0.21		0.03		0,24
2013	A	J19 B4	71	0.30		0.17		0,47
2013	A	J19 B4	73	0.44		0.23	0.012	0,67
2013	A	J19 B4	74	0.26		0.12		0,38
2013	A	J19 B4	76	0.69		0.07		0,76
2013	A	J19 B-C2	78	25.96	6.53	10.87	0.008	43.37
2013	A	J19 A2	79	0.48		0.10		0.58
2013	A	I19 D2	82	3.32	0.13	0.00		3.45
2013	A	J19 A2	83	0.80	0.04	0.04		0.88
2014	A	J20 C1-2	104	0.41		0.06		0.47
2014	A	J20 C2	105	0.10		0.03		0.13
2014	A	J20 C1	110	1.83	0.28	0.22		2.33
2014	A	J20 C1	113	0.23				0.23
2014	A	J20 C1	114	0.73		0.14		0.87
2014	A	J20 C1-2	119	2.97	1.07	0.63		4.66
2014	A	J20 C1	120	10.77	1.31	3.41		15.49
2014	A	J20 C2-3	136	1.51	0.26	0.12		1.89
2014	A	J20 C-D1	140	0.08		0.06		0.15
2014	A	J20 C2-3	142	0.22		0.04		0.26
2015	A	K19 B2	146	0.85	0.17	0.01		1.03
2015	A	K19 A2	147	3.03	0.28	0.40		3.71
2015	A	K19 B-C3-4	150	3.45		0.28	0.01	3.74
2015	A	K19 C1	151	1.03				1.03
2015	A	K19 C2-3	152	0.71		0.05		0.76
2015	A	K19 D2	159	2.12		1.26	0.01	3.40



Fig. 66: Area A: Selection of Plain and *Drab* Wares from the fillings of Building II (SU 17)



Fig. 67: Area A: Selection of Coarse Plates from the fillings of Building II (SU 17)



**Fig. 68:** Area A: Selection of Red Slip Ware sherds from the fillings of Building II (SU 78)





**Fig. 69:** Area A: Selection of Painted Ware sherds from the superficial fillings of Building II (SU 63)



**Fig. 70:** Area A: Selection of Painted Ware sherds from the superficial fillings of Building II (SU 65)



**Fig. 71:** Area A: Selection of Fine, Orange Slip Ware sherds from the superficial fillings of Building II (SU 2)



**Fig. 72:** Area A: Selection of Handmade Red Slip Ware sherds from the fillings of Building II (SU 78)

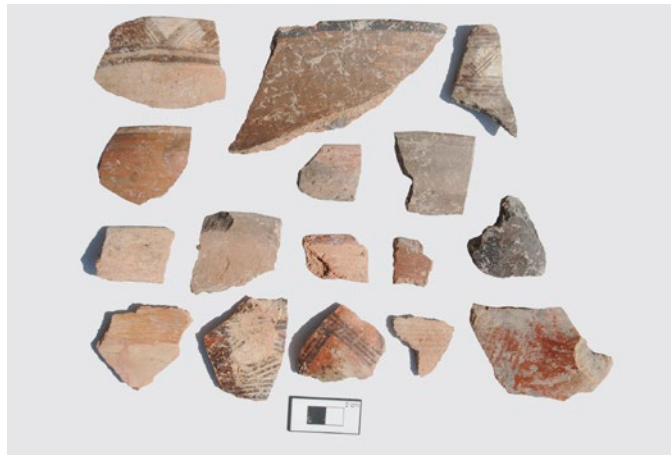

**Fig. 73:** Area A: Selection of Handmade Painted Ware sherds from the fillings of Building II (SU 120)



**Fig. 74:** Area A: Selection of Handmade Painted Ware sherds from the fillings of Building II (SU 17)



Fig. 75: Area A: Selection of Coarse Plates from the deep sounding in room 126, *recto*



Fig. 76: Area A: Selection of Coarse Plates from the deep sounding in room 126, *verso*



**Fig. 77:** Area A: Coarse Plate U13.702, from the deep sounding in room 126, detail of string impressions



**Fig. 78:** Area A: Coarse Plate U13.701, from the deep sounding in room 126, detail of the outer rim



Fig. 79: Area A: Selection of Plain and *Drab* Ware bowls from the deep sounding in room 126 (SU 53): *recto*



Fig. 80: Area A: Selection of Plain and *Drab* Ware bowls from the deep sounding in room 126 (SU 53): *verso*



**Fig. 81:** Area A: Selection of different pottery types from the deep sounding in room 126 (SU 53)



**Fig. 82:** Area A: Wheelmade Red Slip Ware sherd (U13.538) from the deep sounding in room 126



**Fig. 83:** Area A: White Slip Ware sherd (U13.753) from the deep sounding in room 126

### Area D

The ceramic inventory of the surface, sloping fillings above Building III, although clearly mixed, includes a large percentage of painted and burnished pottery types of Middle and Late Iron Age date.

Similarly to Area A-Building II, also in the case of Area D-Building III, the main chronological point of reference for a dating of the structure is constituted by the *terminus post quem* given by the ceramic inventory from the foundation levels of the building. The set of ceramic materials associated with the phase of occupation documented during excavations in 2015, in fact, is very scanty, while most of the pottery derived from the various clayish fillings of the foundations. The attested ceramic types (Figs 84-100) find extensive comparisons with Middle and Late Bronze Age north-central Anatolian ceramic types.

Most of the plain and drab ware samples belong to open shapes and, in particular, to different types of curved bowls with more or less marked anti-splash device, engendered by the thickening of the inner side of the rim profile (Fig. 84: 5, 8-9; Fig. 85: 2-4), and/or by a turning toward the inner side of the vessel of the very upper portion of the wall (Fig. 84: 3, 4, 6). In most cases, the sides have medium-high inclination, then resulting in an intermediate or a rather deep body (Fig. 84: 3-9). More shallow variants, however, are also well attested (Fig. 85: 2-4). The shallow bowl with short banded rim in Fig. 85: 5, which finds some parallel within bowl types S5 (Mielke 2006: pl. 55: 27, type S5-*unicum*; pl. 54: 6, 7, type S5k, Kuşaklı *Westhang*) and S1 (Mielke 2006: pl. 49: 8, type S1a, Kuşaklı *Westhang*; Mühlenbruch 2014: pl. 15: 8, type S1b, Kayalıpınar, *Gebäude B*), bears evident traces of fire on the upper section of the rim and of the sides and, at some point, was most probably used as a lid. The number of large size bowls (Fig. 84: 8-9) is rather limited, while medium (Fig. 84: 6-7) and medium-small size bowls are more numerous (Fig. 84: 3-5; Fig. 85: 1-4).

The large bowls with thick sides and inside thickened rim (Fig. 84: 8-9) belong to morphologies already seen in the test sounding of Area A (Orsi 2018: pl. 1: 7) that are attested throughout the entire Hittite sequence, particularly widespread between the Middle Hittite and the Early Imperial periods, and rooted in the Assyrian colony and Old Hittite ceramic traditions.<sup>21</sup> The morphologies attested here, in particular, recall specimens that seem to be particularly typical of the first part of the Hittite ceramic sequence (cf. Schoop 2006: 228 and fig. 5: H).<sup>22</sup> The variants with thinner walls, which have either medium open (Fig. 84: 3-6) or very open sides (Fig. 85: 2-4), as well as similar types recognised in the test sounding, find comparisons with variants that, despite being attested also in the late stage of the Hittite ceramic sequence, are distinctive of the early and intermediate stages.<sup>23</sup> A relatively

<sup>21</sup> In fact, they are attested throughout the entire Hittite ceramic sequence of central Anatolian sites (Mielke 2006: type S1; Schoop 2006: fig. 4A and fig. 6; Schoop 2008: 47 and figs. 3-4). At Boğazköy Upper City, period 3 (see Müller-Karpe 1988: tab. 29, type S1) and Kuşaklı/Sarissa West Slope (*mittlerer Horizont*) they are particularly widespread between the Middle Hittite and the Early Imperial period (15<sup>th</sup>-14<sup>th</sup> cent. BC), but they are widely attested even earlier, including the Assyrian colony and Old Hittite periods (Mielke 2006: 108 and notes 407-408).

<sup>22</sup> Compare also Fig. 84: 8 with Mielke 2006: pl. 49: 10, 13, type S1b; compare Fig. 84: 9 with Mielke 2006: pl. 49: 20, type S1c. Similarities however are visible also with Parzinger, Sanz 1992: type I2.2b, which was particularly widespread in Boğazköy Upper City period 2.

<sup>23</sup> Most of these samples, in fact, find comparisons with variants identified at Kuşaklı (Mielke 2006), or at Boğazköy (Müller-Karpe 1988) and Kayalıpınar (Mühlenbruch 2014), such as type S12, which is classified as an 'old type' (Mielke 2006: 121), continuing during the entire Hittite sequence and particularly typical of the early and intermediate local ceramic horizons (16<sup>th</sup>-14<sup>th</sup> cent. BC), and type S5, attested during the entire sequence of Kuşaklı West Slope (16<sup>th</sup>-13<sup>th</sup> cent. BC) and particularly typical of the local intermediate ceramic horizon (15<sup>th</sup>-14<sup>th</sup> cent. BC). Comparisons with bowl type S12 are visible in Uşaklı samples shown in Fig. 84: 4 (Müller-Karpe 1988: pl. 40, type S12a, n. 25); Fig. 85: 1 (Müller-Karpe 1988: pl. 40, type S12b, n. 4, Boğazköy *Oberstadt*; Mielke 2006: pl. 57: 23-24, type S12b, Kuşaklı *Westhang*; Müller-Karpe 1988: pl. 40, type S12c, ns. 1-2, Boğazköy *Oberstadt*. Cf. also Fischer 1963: pl. 83: 696-697, Büyükkale lev. IVb). Comparisons with bowl type S5 are visible in Uşaklı samples shown in Fig. 84: 5 (Mielke 2006: pl. 55: 1, type S5p, Kuşaklı *Westhang*; Mühlenbruch 2014: pl. 21: 26, type S5x, Kayalıpınar); Fig. 84: 6 (Mühlenbruch 2014: pl. 21: 31, type S5x, Kayalıpınar. Cf. also Fischer 1963: pl. 86: 743, Büyükkale IVb); Fig. 84: 7 (Mielke 2006: pl. 54, type S5m, Kuşaklı *Westhang*); Fig. 85: 2 (Mühlenbruch 2014: pl. 20: 18, type S5q; pl. 20: 32, type S5s, Kayalıpınar); Fig. 85: 4 (Müller-Karpe 1988: pl. 37, type S5p n.1, Boğazköy *Oberstadt*).



high number of these shapes, in fact, recall also Assyrian colony and Old Hittite period samples.<sup>24</sup> Among these, hemispherical bowls with slightly inturned rim, which are attested both with plain (Fig. 84: 3) or red slipped surface (Fig. 91: 5-6), are considered particularly typical of the first part of the Hittite ceramic sequence, but they derive from handmade Early Bronze Age prototypes, and continue to be attested during the Assyrian colony period (Schoop 2011: 243-245 and fig. 1A).<sup>25</sup> Very thin sided vessels, also classified as *Eggshell Ware*, at Boğazköy appear firstly in 15<sup>th</sup> century contexts, but they are considered more characteristic of the later stages of the Hittite sequence (Schoop 2009: 154-155). The morphological variants of fine ware vessels attested in the foundation levels of Building III (Fig. 84: 1-2), however, seem to find good comparisons also with older typologies, attributed to the Assyrian colony and Old Hittites periods.<sup>26</sup>

Among the closed shapes, thin-sided small jars with curved shoulder and outside thickened or everted rim (Fig. 85: 8) are attested both with plain or red slipped surface, and find comparison from the Assyrian colony and Old Hittite period until the late stages of the Hittite ceramic sequence (see Mielke 2006: type T20, p. 101).<sup>27</sup> High necked jars and jugs (Fig. 85: 6-7) are also documented by rim and rim-and-neck fragments, but the limited portion of preserved profiles do not permit any sound evaluation of the original shape of reference. The rims, however, find comparisons with specimens belonging to shapes that are classified at Kuşaklı under the label of type K2 (Mielke 2006: pl. 4: 55-58, type K2i), K4 (Mielke 2006: pl. 9: 18-19, type K4i) or K6 (Mielke 2006: pl. 10: 34-36 type K6g).

Quite notable seems to be the very low incidence of the kitchen/cooking ware and in particular of coarse plates, of which a single example has so far been documented. Outside thickened rim cooking pots with a ridge on the shoulder (Fig. 85: 9-10) have been found in the Upper City contexts of Boğazköy (Parzinger, Sanz 1992: pl. 2: 6-7; Müller-Karpe 1988: pl. 12, type KT5); the shape is associated with the Upper City period 3 (15<sup>th</sup>-14<sup>th</sup> cent. BC), but it is quite rare (Parzinger, Sanz 1992: fig. 34, types B2a-b).

Quite large, instead, is the inventory of red slip ware (Figs 91-96). The use of the red slip constitutes an aspect of marked continuity in the central Anatolian ceramic productions, being attested from the Early Bronze Age, where it is mainly found in association with handmade pottery, well into the Middle and Late Bronze Ages, and, to some extent, into the Iron Age.<sup>28</sup> Many red slip ware types attested in these levels are common to both the Assyrian colony and the Early Hittite periods, whose ceramic traditions, in fact, are characterised by quite a marked continuity (Schoop 2009: 150-152). The inventory includes examples where the slip covers most the vessels surface (Figs 92, 93, 94- lower rows, 95), more typical of the Assyrian colony period and of the early phases of the Hittite sequence (Schoop 2009: 151), as well as examples where the red slip is limited to a narrow band on

<sup>24</sup> Specifically, Fig. 84: 1 (cf. with Müller-Karpe, V. 2009: fig. 16: 13, Kayalıpınar lev. 5; Orthmann 1963: pl. 30: 270, Boğazköy *NW-Hang*, lev. 8b. See commentary in the text); Fig. 84: 2 (cf. with Müller-Karpe, V., 2009: fig. 16: 15, Kayalıpınar lev. 5. See commentary in the text); Fig. 84: 3 (for which see the commentary in the text); Fig. 84: 4 (cf. Fischer 1963: pl. 88: 759, Boğazköy *Unterstadt*, lev. 4); Fig. 85: 1 (cf. with Orthmann 1963: pl. 36: 339, Boğazköy, *NW-Hang*, lev. 8a; Fischer 1963: pl. 83: 689, Büyükkale lev. IVd); Fig. 85: 3 (cf. with Orthmann 1963: pl. 30: 263-262, Boğazköy *NW-Hang*, lev. 8b)

<sup>25</sup> Similar morphologies at Kayalıpınar are mainly associated with the group of bowls type S12, and in particular to the sub-type S12o (Mühlenbruch 2014: pl. 25: 19, type S12o, Kayalıpınar *Gebäude B*). Related variants, however, appear also within bowl type S5, and in particular within the sub-types S5x (Mühlenbruch 2014: pl. 21: 25) and S5t (Mühlenbruch 2014: pl. 20: 38). Although attested for the entire sequence of Building B, the climax of all sub-variants is attributed to level 4, dating to the Old Hittite period (Mühlenbruch 2014: 292).

<sup>26</sup> Compare Fig. 84: 1 with Müller-Karpe, V. 2009: fig. 16: 13, Kayalıpınar, lev. 5; Orthmann 1963: pl. 30: 270, Boğazköy *NW-Hang*, lev. 8b. Compare Fig. 84: 2 with Müller-Karpe, V. 2009: fig. 16: 15, Kayalıpınar lev. 5. As for later contexts, some related morphologies are classified within types S12 (See Kuşaklı *Westhang*, Mielke 2006: pl. 57: 7, 9, type S12b; pl. 57: 38, type S12c; pl. 58: 26, type S12i; Kayalıpınar, *Gebäude B*, Mühlenbruch 2014: pl. 24: 32, type S12e).

<sup>27</sup> See in particular Mielke 2006: pl. 42: 5, type T20e; Müller-Karpe 1988: pl. 26, type T20f, n. 2; Mielke 2006: pl. 42: 15, type T20g; Mühlenbruch 2014: pl. 11: 13, type T20b; pl. 11: 17, 18, type T20d.

<sup>28</sup> Red slipped wares seem to be less common in the Iron Age than in the Bronze Ages, but they are all the same well attested (see, for example, Genz 2004: pl. 67: 3-4, Middle Iron Age; Genz 2007: 142, Late Iron Age; Kealhofer et al. 2010: 84). Red slip ware sherds, in addition, have been found also at Uşaklı Höyük in the Iron Age levels of Area D during the 2017 excavations.

the mouth (Fig. 91: 7-9; Fig. 94-upper rows), which is a characteristic more common in later assemblages (Schoop 2009: 151).<sup>29</sup> Most common morphologies are referable to carinated bowls, either with elongated (Fig. 91: 10-11) or short upper section (Fig. 91: 7-9). Carinated bowls with elongated upper section (Fig. 91: 10-11, fig. 93-upper row, left side), many of which would have included a horizontal handle with triangular section (see Fig. 93; Fig. 94-lower rows on the right; Fig. 95-upper rows on the right; Fig. 96-lower row on the middle and right), are quite common. The shape derives from the Early Bronze Age handmade prototypes. The wheelmade variant is mainly attested from the Assyrian colony period until the intermediate stage of the Hittite ceramic sequence. In the sequence of Boğazköy, in particular, they sharply decline after the Assyrian colony period. Although in small percentages they are still attested in the contexts dating to the 16<sup>th</sup> century BC, but seem to disappear immediately afterwards (Schoop 2009: 151).<sup>30</sup> S-shaped bowls with thin sides (Fig. 91: 3-4), which are attested also with vertical handle (Fig. 91: 4), although found in some variants in Late Bronze Age contexts<sup>31</sup> seem quite widespread in earlier contexts.<sup>32</sup> Spouted vessels (Fig. 91: 12; fig. 95-third row on the left; fig. 96-lower row on the right) are also quite common, as well as vertical handles (Fig. 92-at the bottom, right side), which may relate to cups or small jars.<sup>33</sup>

Also remarkable is the relatively high incidence of the so-called gold wash ware (Fig. 91: 1-2; Fig. 97. See also D'Agostino, Orsi 2018: fig. 7), which is a particularly fine ware characterized by a thin coat of glistening gold-coloured particles, most probably mica, thin walls and very fine fabric. Although the inventory of Uşaklı Höyük potsherds with glistening, gold-coloured wash is relatively standardized, a few variants may be recognized in terms of both morphology and technology. Most of the gold wash ware samples from Uşaklı Höyük belong to open shapes, and namely to small, thin-walled bowls with carinated sides and vertical or everted upper sections (Fig. 91: 1-2), but a few sherds of small jars are also attested (see as example Fig. 97, U15.1342). In the archaeological literature, it is noted that the morphology of gold wash ware vessels is usually somewhat different from the rest of the assemblage (Schoop 2011: 261), but at Uşaklı some general parallels with red slip ware shapes, namely in the carinated bowls with everted upper sections, seem to be relatively close (compare Fig. 91: 2, in gold wash ware; Fig. 112: 1, in red slip ware, and Fig. 97: U15.1668, with red slipped and gold washed surface, mentioned below. See also D'Agostino, Orsi 2015: fig. 10: 223, 225 [gold wash], and D'Agostino, Orsi 2015: fig. 10: 224, 226, 228 [red slip]). As far as technological aspects are concerned, samples with very fine fabric, dense and well sorted texture, almost no visible inclusions and homogeneously oxidised section<sup>34</sup> are distinguishable from some less fine variants, characterized by the presence of some visible inclusions, mainly small and white in colour, and sandwich fracture, with orange margins and greyish core (see as example U15.1539, Fig. 91: 1 and Fig. 97). Moreover, the gold-coloured wash appears directly over the surface in the finer examples, while it seems to be applied together with an additional whitish wash (Munsell soil colour chart 5YR 8/2 - pinkish white, or 5YR 7/4 - pink) in less fine samples (U15.1539).<sup>35</sup> An additional third variant is testified by a rim-herd (U15.1668, Fig. 97), apparently in common ware, where a whitish/pinkish coat (Munsell soil colour chart 7.5YR 7/3 - pink) with sparkling-gold

<sup>29</sup> At Boğazköy, in particular, the greatest drop in the quantity of red slip ware is registered in the 16<sup>th</sup> century BC, when it falls values of over 20% of the ceramic assemblages to less than 10% (Schoop 2009: 151 and fig. 8).

<sup>30</sup> Cf. Fischer 1963: pl. 88: 765, Boğazköy *Unterstadt*, lev. 4; Orthmann 1963: pl. 31, Boğazköy *NW-Hang*, lev. 8b; Mühlenbruch 2014: pl. 28: 1-19, type S22, Kayalıpınar *Gebäude B*. Some similarity, however, is visible also with specimens classified within types S6 (cf. Fig. 91: 10 with Mielke 2006: pl. 56: 4-5, type S6a) S8 (cf. Fig. 91: 11 with Mielke 2006: pl. 56: 19-20, 24-25, type S8) S18 (cf. Fig. 91: 11 with Mühlenbruch 2014: pl. 26: 17-20, type S18a; 21-24, type S18b) and S12 (Müller-Karpe 1988: pl. 40, type S12e, nos 2-4, 6-7 and 11-12). Some of the variants with short upper section (see Fig. 91: 8) also find good comparisons in the Assyrian colony and Old Hittite periods (Fischer 1963: pl. 88: 758, Boğazköy *Unterstadt*, lev. 5, red slip ware; pl. 85: 724, Büyükkale lev. IVc, plain ware; pl. 88: 760, Boğazköy, *Unterstadt*, lev. 4, red slip ware)

<sup>31</sup> See Mielke 2006: pl. 59: 1, 6, type S18a, S18b; pl. 62: 16, type S10-*unicum*; Müller-Karpe 1988: pl. 38, type S10a, nos 1, 3-brown polished surface; Mielke 2006: pl. 57: 34-35, type S12e.

<sup>32</sup> See Orthmann 1963: pl. 39: 3-4, Alaca Höyük; pl. 40: 4-5, Polatlı; Orthmann 1963: pl. 8: 23-26, Boğazköy *NW-Hang*, lev. 9.

<sup>33</sup> See as a reference for probable shape Fischer 1963: pl. 82

<sup>34</sup> See as a reference D'Agostino, Orsi 2015: pl. 31, K08.1086.

<sup>35</sup> The presence of an additional white or cream slip has already been recorded at other sites, but it is considered rarer: in most cases, in fact, the glistening wash is directly applied to the surfaces (Schoop 2011: 260).

particles is applied over a thin, red slip (Munsell soil colour chart 10R 5/8 - red), whose traces appear quite clearly in correspondence with the inner side carination. This peculiar potsherd, in fact, appears as a sort of combination of red slip ware and gold wash ware attributes: the fabric of the sherd, to the unaided eye, seems to be quite similar to those commonly attested in red slip ware potsherds, and the morphology, which is referable to a carinated bowl with everted upper sides and sharpened rim, is attested in both ceramic classes.

The concurrent use of red slip and gold wash, however, is not isolated at Uşaklı Höyük, finding a comparison in a few body-sherds referable to closed shapes (see here U15.1342, Fig. 97). The resulting appearance recalls, to some extent, the bicolour pattern obtained through the use of double slip (or slip plus paint) in red and whitish/yellow colours (see here U15.1740 and U15.1741, Fig. 93, bottom, left and right sides), or through the sapient use of slip reservation (for which see D'Agostino, Orsi 2015: 84, 173, and 393, pl. 17: 7, K08.1026, K08.1027).

Given the absence of micaceous clays inside the Kızılırmak bend, this specific ware, or the raw material for its coating, is thought to have been imported into Central Anatolia (Matsumura 2005: 123-124): the precise area of origin is not known, but general connections are proposed with southwestern Anatolia productions (Schoop 2011: 261). The differences observed in gold wash potsherds at Uşaklı Höyük, however, testifies to slightly distinguished variants,<sup>36</sup> whose presence leaves space for different explanations. They might be connected to different places of origin and different workshops, or, in the case of a rather circumscribed place of origin, to a relatively low standardized production system. A differentiation between imported examples and local imitations might also be likely, as it seems especially in the case of the common ware bowl with red slipped and gold washed surface (U15.1668, Fig. 97). For each hypothesis mentioned above, an additional chronological differentiation is also possible.

The dating of this specific ware is not perfectly settled, but there is fairly widespread agreement that Late Bronze Age gold wash ware types are substantially typical of the first half of the Hittite ceramic sequence (Schoop 2011: 261) and should not be later than the early Imperial period (Mielke 2006: 41).<sup>37</sup>

The presence of abundant glistening particles, mainly gold-coloured, clearly visible to the unaided eye, however, has been observed elsewhere in the Uşaklı Höyük ceramic production, and namely on the surface, or both on surface and fracture, of Iron Age common ware types (especially bowls with simple, curved profile).<sup>38</sup> It is not possible to tell, at this stage of the study and without the assistance of laboratory analyses, if the glistening appearance of the fine ware types, mainly of Late Bronze Age period, and of the other examples, may be the result of consistency in fabric composition and/or production technique.<sup>39</sup> Nevertheless, it seems worth noting the recurrence, over a long span of time, of a predilection for a shining superficial appearance.

Early Bronze Age/Middle Bronze Age handmade red slip and painted wares (Figs 98-100), in addition, constitute a relatively large component of the inventory of the Building III foundations.

Overall, despite the large number of parallels that may be ascribed to the first half of the Hittite ceramic sequence, their long range of attestation in North-Central Anatolian sites prevents a precise dating of the foundation assemblage on the sole basis of comparisons. On preliminary evaluation, if compared to the ceramic inventory recovered from the test sounding under Area A Building II, the presence of a large set of red slip ware, most common in the Assyrian colony period and in early phases of the Hittite ceramic sequence (Schoop 2011: 243), together with the limited quantity of drab ware types more typical of the latest phases, however, may be the evidence of

<sup>36</sup> A similar variability, however, can also be noted at other sites. At Böğazköy, for example, similar morphologies are reported with brown slipped surface (Fischer 1963: pl. 98: 899), with a thin silvery-yellow slipped surface (Fischer 1963: pl. 98: 895) and with a white slipped surface (Fischer 1963: pl. 98: 888).

<sup>37</sup> See D'Agostino, Orsi 2015: 65-66 for a more extensive overview of references.

<sup>38</sup> This seems to find a comparison at Kaman-Kalehöyük, where wares that seem to be related to the Late Bronze Age gold wash ware are reported also in the 1<sup>st</sup> millennium BC. Namely, two variants are reported: one with evident gold coloured particles, and a second with gold coloured particles invisible to the unaided eye (Matsumura 2005: 123-124).

<sup>39</sup> A peculiarity to consider in this respect is also that, whilst the Late Bronze Age gold wash ware samples (or some of them) must be considered as imports at Uşaklı Höyük, the later potsherds with glistening particles, appearing as a common ware kind of production, seem more probably to have been produced locally.

an earlier range of dating.<sup>40</sup> The chronological relation between the ceramic inventory deriving from the foundations of Building III and its actual construction, as well as in the case of Area A Building II and the material of the test sounding, may be either of contemporaneity or of posteriority. Of some interest also seems to be the relatively high frequency of fine wares, here including the gold wash ware, which might be related to a functional connotation of the area of origin of the sherds.

**Chart 5:** Uşaklı Höyük 2013-2015. Materials recovered in Area D

Year	Area	Square	Stratigraphic Unit	Diagnostic Potsherds (Number)	Generic Potsherds (Number)	Potsherds Total (Number)	Slags (Weight in Kg)	Roof Tiles (Weight in Kg)
2015	D	O15 A2	1	12	30	42	0.016	
2015	D	O15 A-B2	3	120	347	467	0.012	
2015	D	O15 A-B2	4		3	3		
2015	D	O15 B-C2	11	7	25	32		
2015	D	O15 B2-3	12	67	174	241	0.008	
2015	D	O15 B-C2	14	5	13	18		
2015	D	O15 A2-3	20	40	111	151	0.283	
2015	D	O15 A-B3	21	149	392	541		
2015	D	O15 A-B3	22	5	17	22		
2015	D	O15 A3	25	5	16	21		
2015	D	O15 A3	28	3	5	8		
2015	D	O15 A3	29	2	1	3		
2015	D	O15 A3	32	1	2	3		
2015	D	O15 A3	38	7	16	23	0.005	
2015	D	O15 A3	40	8	12	20		
2015	D	O15 A-B3	44	78	203	281		
2015	D	O15 A-B3	48	49	201	250		
2015	D	O15 A-B3	49	61	175	236		
2015	D	O15 A3	52	16	64	80		
2015	D	O15 A2	57	4	16	20	0.071	
2015	D	O15 A-B3	62	11	63	74		
2015	D	O15 A-B3	63	35	111	146		
2015	D	O15 A-B3	64	12	14	26		
2015	D	O15 A-B3	67	59	76	135		
2015	D	O15 A-B3	69	4	12	16		
2015	D	O15 A-B3	70	9	24	33		
2015	D	O15 A3	71	6	33	39		
2015	D	O15 A-B3	73	36	97	133		
2015	D	O15 A-B3	74	12	25	37		
2015	D	O15 A-B3	75	14	52	66		
2015	D	O15 A-B3	S-Kova 3-selection	37	46	83		
2015	D	O15 A3	S-Kova 4	9	13	22	0.071	
2015	D	O15 A3	S	32	66	98	0.172	
2015	D	O15 A3	S-Locus 3	14		14		

<sup>40</sup> A more precise range, however, will be hopefully obtained from the dendrochronological analysis of carbon samples recovered during the 2017 excavation season and associated with the construction of the Building, which should provide a sound reference *ante quem* for the ceramic inventory of the foundations.

**Chart 6:** Uşaklı Höyük 2013-2015. Qualification of potsherds recovered in Area D

Year	Area	Square	Stratigraphic Unit	Common Ware (Weight in Kg)	Storage Ware (Weight in Kg)	Kitchen Ware (Weight in Kg)	Fine Ware (Weight in Kg)	Ceramic Total (Weight in Kg)
2015	D	O15 A2	1	1.07		0.25		1.32
2015	D	O15 A-B2	3	10.17	1.84	1.25	0.02	13.28
2015	D	O15 A-B2	4	0.12				0.12
2015	D	O15 B-C2	11	0.64		0.17		0.81
2015	D	O15 B2-3	12	5.19	1.15	1.33	0.014	7.68
2015	D	O15 B-C2	14	0.40		0.08	0.002	0.48
2015	D	O15 A2-3	20	2.86	0.50	0.69	0.007	4.05
2015	D	O15 A-B3	21	10.83	0.89	2.14	0.04	13.90
2015	D	O15 A-B3	22	0.67				0.67
2015	D	O15 A3	25	0.44		0.04		0.47
2015	D	O15 A3	28	0.12				0.12
2015	D	O15 A3	29	0.09				0.09
2015	D	O15 A3	32	0.22				0.22
2015	D	O15 A3	38	0.26			0.006	0.27
2015	D	O15 A3	40	0.53		0.03		0.56
2015	D	O15 A-B3	44	4.83	0.42	0.71	0.137	6.09
2015	D	O15 A-B3	48	4.82		0.40	0.040	5.25
2015	D	O15 A-B3	49	3.80	0.25	1.50		5.55
2015	D	O15 A3	52	1.31	0.82		0.087	2.22
2015	D	O15 A2	57	0.40				0.40
2015	D	O15 A-B3	62	1.10	0.10	0.83		2.02
2015	D	O15 A-B3	63	2.43		0.33	0.022	2.78
2015	D	O15 A-B3	64	0.39	0.27			0.66
2015	D	O15 A-B3	67	4.28		0.37	0.027	4.68
2015	D	O15 A-B3	69	0.30		0.18		0.48
2015	D	O15 A-B3	70	0.38		0.23		0.60
2015	D	O15 A3	71	0.46		0.22	0.004	0.68
2015	D	O15 A-B3	73	2.35		0.46		2.81
2015	D	O15 A-B3	74	0.35		0.11		0.46
2015	D	O15 A-B3	75	0.65		0.30		0.95
2015	D	O15 A-B3	S-Kova 3-selection	2.73		0.17		2.90
2015	D	O15 A3	S-Kova 4	0.50		0.28		0.78
2015	D	O15 A3	S	2.04	0.82	0.18		3.04
2015	D	O15 A3	S-Locus 3	0.66		0.08		0.74

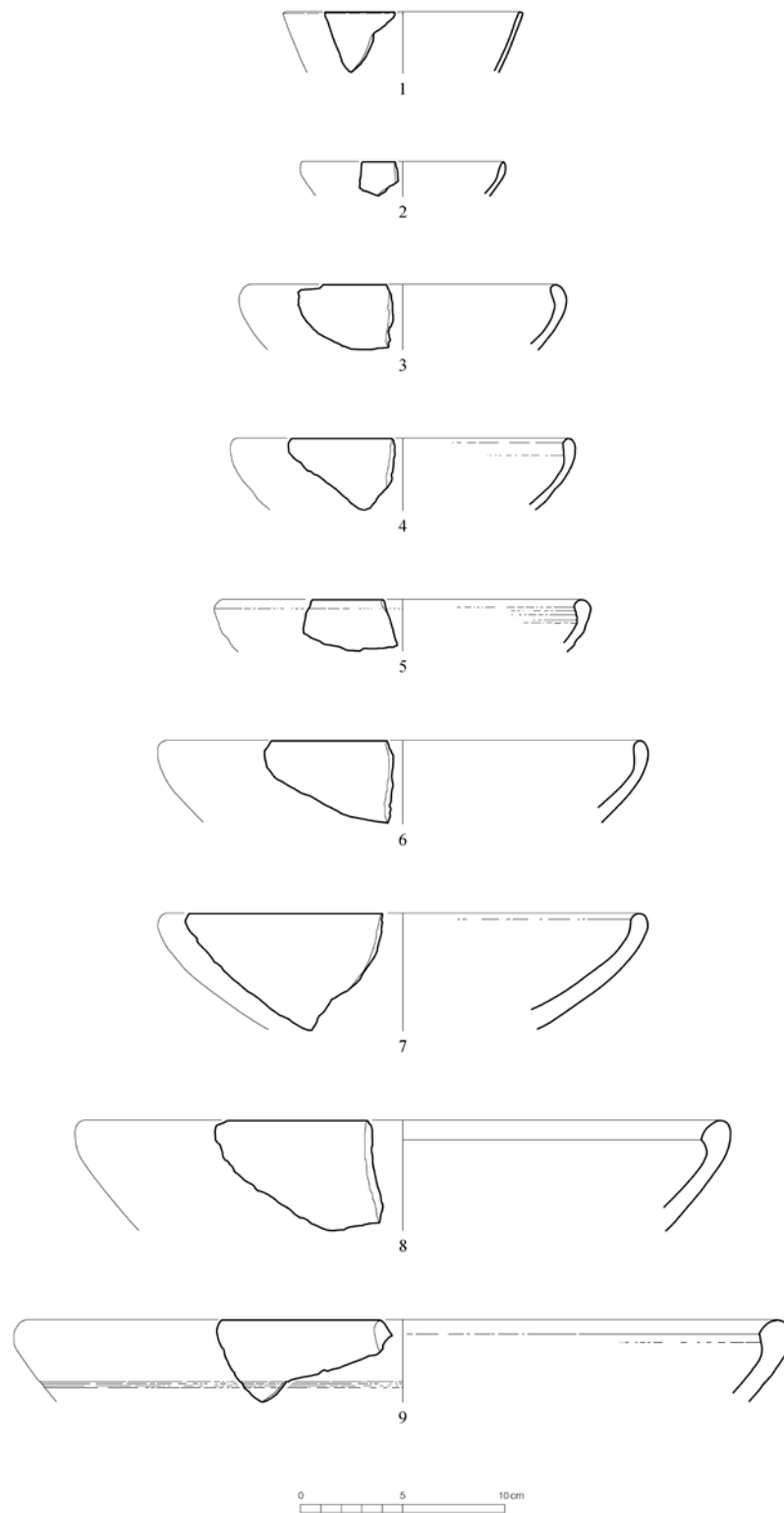

**Fig. 84:** Area D: Selection of Plain and *Drab* Ware bowls from the foundation levels of Building III, rooms 58 and 59

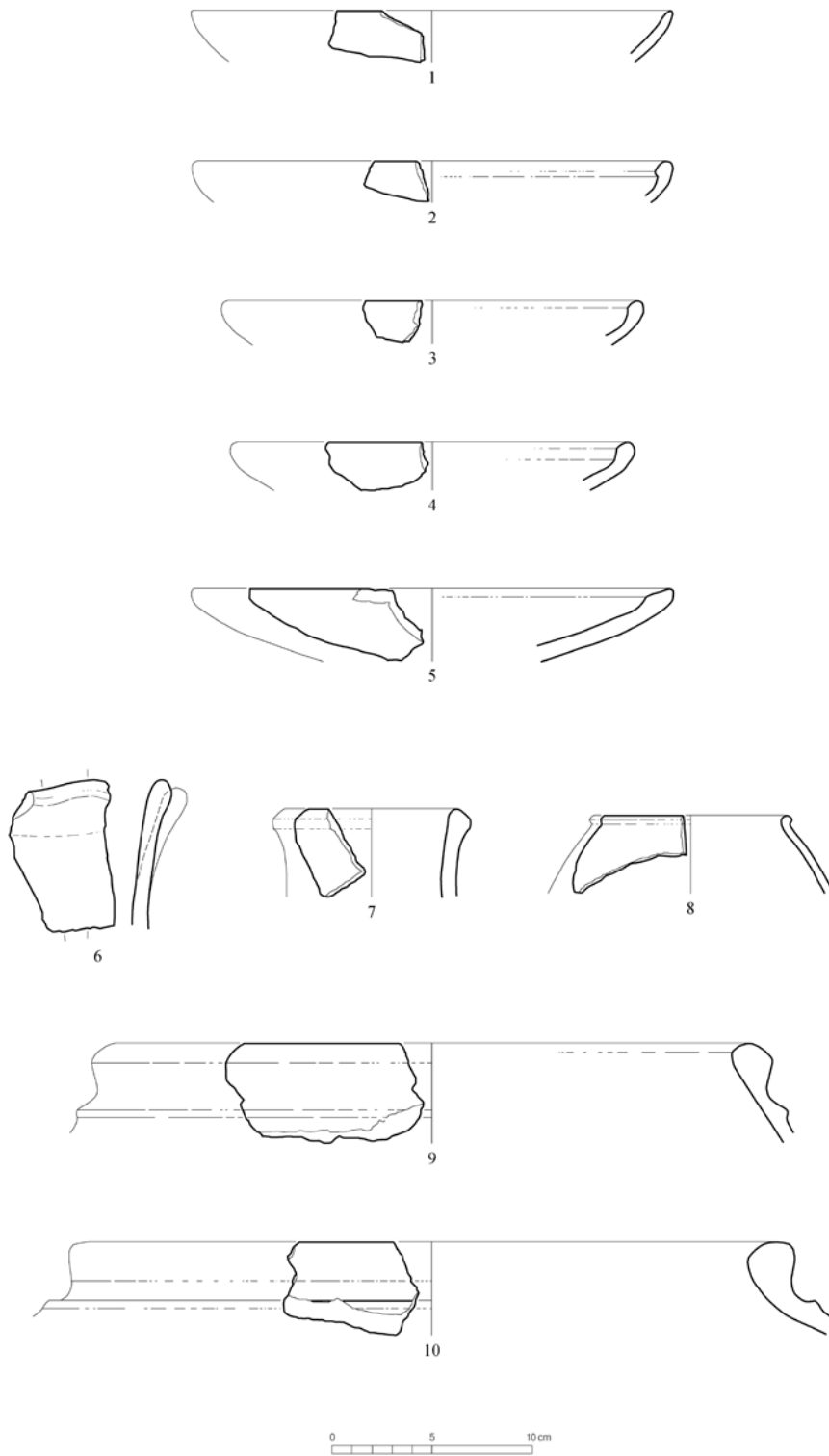

**Fig. 85:** Area D: Selection of Plain and Kitchen Ware sherds from the foundation levels of Building III, rooms 58 and 59



**Fig. 86:** Area D: Selection of pottery sherds from the foundation levels of Building III, room 59 (SU 3)



**Fig. 87:** Area D: Selection of pottery sherds from the foundation levels of Building III, room 58 (SU 48)



**Fig. 88:** Area D: Selection of pottery sherds from the foundation levels of Building III, room 58 (SU 67)

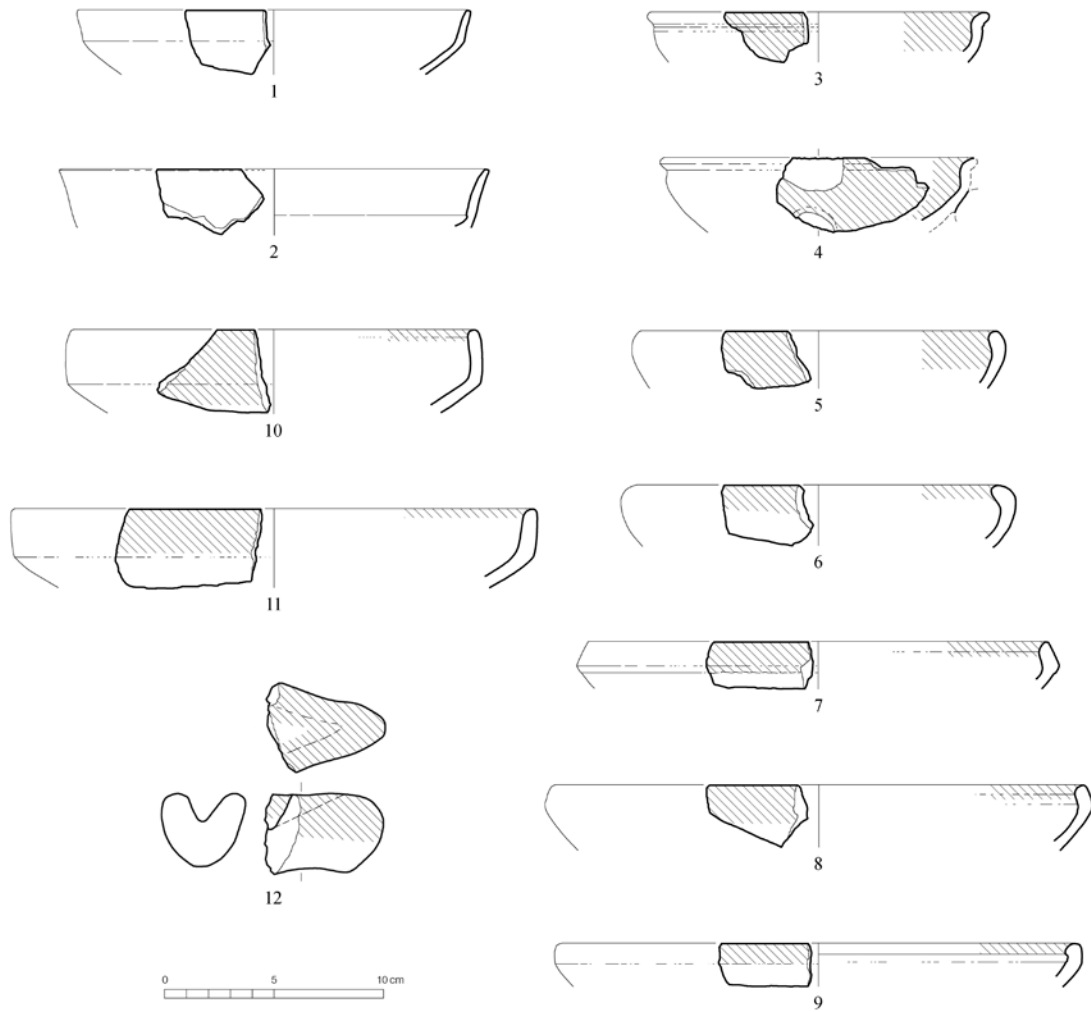

**Fig. 89:** Area D: Detail of a Drab Ware bowl from the foundation levels of Building III, room 58 (SU 73)



**Fig. 90:** Area D: Detail of a Drab Ware bowl from the foundation levels of Building III, room 59 (SU 3)





**Fig. 91:** Area D: Selection of *Gold Wash Ware* sherds (nos 1-2) and *Red Slip Ware* sherds from the foundation levels of Building III, rooms 58 and 59



**Fig. 92:** Area D: Selection of *Red Slip Ware* sherds from the foundation levels of Building III, room 58 (SU 69)



**Fig. 93:** Area D: Selection of *Red Slip Ware* sherds from the foundation levels of Building III, room 58 (SU 73)



**Fig. 94:** Area D: Selection of Red Slip Ware sherds from the foundation levels of Building III, room 58 (SU 44)



**Fig. 95:** Area D: Selection of Red Slip Ware sherds from the foundation levels of Building III, room 58 (SU 67)



**Fig. 96:** Area D: Selection of Plain and Red Slip Ware sherds from the foundation levels of Building III, room 58 (SU 3)



**Fig. 97:** Area D: Gold Wash Ware potsherds from the foundation levels of Building III, room 58 (U15.1538; U15.1539, SU 63), room 59 (U15.1342, SU 3) and from SU 12 (U15.1668)



**Fig. 98:** Area D: Selection of Handmade sherds from the foundation levels of Building III, room 59 (SU 3)



**Fig. 99:** Area D: Selection of Handmade Painted Ware sherds from the foundation levels of Building III, room 58 (SU 73)



**Fig. 100:** Area D: Detail of a Handmade Painted Ware potsherd from the foundation levels of Building III, room 58 (SU 63)

### Area C

Excavations in Area C revealed a large and interesting sequence of mainly Middle Iron Age ceramics deriving from clayish accumulation layers which lay directly over the virgin soil (Fig. 101-102).<sup>41</sup> The inventory includes a large number of painted examples. Judging on the basis of the relative regularity of the mouth, and of the thickness of the walls, they appear generally wheelmade, but the extensive use of burnishing for the treatment of the surface makes it difficult, in some cases, to give a sound evaluation of the building technique. A mixed building technique might be also likely, especially in case of large vessels. The painted decoration, as with the main Middle Bronze Age North-Central Anatolian ceramic assemblages, is primarily monochrome, but several bicolour sherds were also found. In the sherd U15.641 (Fig. 101: 5), for example, a red paint was used at the crossing of the lines which framed the reticulated rhombs, while for all the other motifs the more common darkish-brown colour was used. Although in south-eastern central Anatolia a bichrome painted decoration style is already attested in the Early Iron Age (Genz 2003: 185), especially exemplified by Kaman-Kalehöyük levels IId 1-3 and Porsuk IV (Matsumura 2008), the appearance of bichrome painted pottery in central-north Anatolia is usually located in the Middle Iron Age. In particular, on the hill of Büyükkale, it starts to be attested with the Büyükkale-II stage that, following the Büyükkaya stage, assigned to the 9<sup>th</sup> century BC by radiocarbon dates (Seeher 2000: 20), constitutes the second phase of the local Middle Iron Age sequence (Genz 2000: 38 and fig. 8: 7-10; fig. 16; Genz 2001: 160).<sup>42</sup> The darkish, mat paint is the most frequent (Munsell soil colour chart 7.5YR 4/1 - dark grey; 7.5YR 2.5/1 - black; 7.5YR 3/2 - dark brown), but a brownish purple variant (5YR 3/3 - dark reddish brown; 5YR 3/1 - very dark grey; 10R 2.5/1 - reddish black) is also well attested. The fabrics are usually brownish or orange in colour, sometimes with a darker core indicating a nonoptimal firing process. Yellowish fabrics are also attested. The surfaces of the vessels are frequently yellowish, brownish or reddish brown in colour. Brownish and reddish surfaces are frequently simply burnished, while the yellowish colours may be more frequently the result of a thin slip. The painted patterns are predominantly geometric, made of a combination of straight and wavy lines or bands and short strokes. Although quite rare, animal 'silhouette' motives typical of the Alişar IV period, which were not attested from the surface inventory (D'Agostino, Orsi 2015: 71, 176), have been uncovered in these layers (Figs 102 and 105). A fine-grained chronology for this pottery type is still under discussion,<sup>43</sup> but its main diffusion seems to be attributed primarily to the 9<sup>th</sup> cent. BC (Kealhofer, Grave 2011: 427).

The animal silhouettes, in darkish, mat paint, are in association with concentric, double circles, which are frequently used as filling motif also in the non-naturalist, geometric combinations. Unpainted, wheelmade examples, which are also well attested, usually present a burnished surface.

Most common shapes include curved bowls with slightly-thickened or thickened rim (Fig. 101: 1-4) and craters with grooves on the inside of the rim (Fig. 101: 5-6). Painted sherds of spouts (Fig. 103) and handles, belonging to craters (Fig. 104) or jugs and pitchers are also quite frequent.

<sup>41</sup> Since a generally accepted chronological system for Iron Age Central Anatolia is still lacking, and a fine-grained correlation between historical, ceramic and absolute sequences is problematic (Summers 2008; Kealhofer, Grave 2011: 417-420), here reference is made primarily to the relative sequence of pottery style as summarized by H. Genz (Genz 2011: 332-335). For the Iron Age pottery in general see Genz 2004, 2005, 2007, 2011.

<sup>42</sup> Originally ascribed primarily to the 8<sup>th</sup> century BC (Genz 2001: 160; Genz 2004: tab. 6), the dating of the Büyükkale-II stage has been slightly extended backward to include the 9<sup>th</sup> century on the basis of subsequent refinement of the Central Anatolian chronologies (Genz 2006: 133; Kealhofer et al. 2009: tab. 1).

<sup>43</sup> At Böğazköy, monochrome, strictly geometric decoration is associated with the Büyükkaya stage, which represents the first Middle Iron Age stage in the local sequence; silhouette style motifs, together with the bichrome painting, instead, start to be attested only in the following Büyükkale II-stage (Genz 2000: 38; Genz 2001: 160), to be attributed to the 9<sup>th</sup> and 8<sup>th</sup> centuries BC (see previous note). An additional point of reference for the diffusion of Alişar IV silhouette motifs is their attestation in the Early Phrygian Building level V of Gordion that, on the basis of the revised local chronology, is attributed to the second half of the 9<sup>th</sup> century BC (Sams 2012: 61-63). The development of the Alişar IV painted style has been located in the bend of the Kızılırmak river during the Early Iron Age (Summers 2009: 661, quoting Seeher 1998 and Genz 2000. See also Matsumura 2008). 10<sup>th</sup> and 9<sup>th</sup> centuries BC have been recently suggested as the main period of circulation and popularity of the type (D'Alfonso et al. 2016: 602) but, as highlighted by G. Summers (Summers 2009: 660) it seems to be well attested until the 7<sup>th</sup> century BC (and spec. 9<sup>th</sup>-7<sup>th</sup> cent. BC). For general considerations on Alişar IV style pottery see Summers 2014: 45; Summers 2009: 660-662; Matsumura 2008, 42; Bossert 2000: 46-51; Genz 2000: 38.

In the same fillings, a few handmade sherds and potsherds with reddish paint might be ascribed to the Early Iron Age central-north Anatolian ceramic horizons (for which see Genz 2003; Genz 2004: 24-28). Although probably to be considered intrusive in these later layers, they would constitute a first trace of occupation of the site during the Early Iron Age, clear evidence of which had not been registered during the surface survey (D'Agostino, Orsi 2015: 169, 175).<sup>44</sup>

Of particular note is the ceramic inventory provided by the bulk of alternated burnt and ashy soils (SU 28, SU 69 and SU 70), which cover and are covered by the clayish layers (Figs. 106-114). This, in fact, consists mainly of Middle and Late Bronze Age types, including typical plain drab ware and red slip ware examples. Red slip ware types and morphologies widespread from the Assyrian colony period and into the first part of the Hittite ceramic sequence are well attested (Fig. 112: 4-5; Fig. 113), together with probable later types, like the bowls where the red slip is limited to a band on the vessel's mouth (see Schoop 2003a: 15; Schoop 2009: 151). Red slip ware carinated bowls with everted sides (Fig. 112: 1), for example, are attested in the 14<sup>th</sup> century contexts of the valley west of Sarikale, at Boğazköy (Schoop 2003a: fig. 19: 13).

Plain ware types belong to typologies widespread in different parts of the Hittite ceramic sequence, most of them already attested in the test sounding of Area A (see Orsi 2018). Noteworthy, however, is the presence of types more frequent in the late stages of the Hittite sequence: deep vessels with outside thickened, squared rim (Fig. 106: 7), seem to be mainly widespread in contexts of 13<sup>th</sup> cent. BC (cf. Müller-Karpe 1988: 61, type T1;<sup>45</sup> Mielke 2006: 86, and Annex 6, type T 1; Schoop 2003b: fig. 4: 2), and the morphology of the coarse plates (Fig. 106: 9) finds comparisons with variants that are typical of the later stages.<sup>46</sup>

In addition, a few sherds probably to be related to the ceramic horizon of the so-called Red Lustrous Wheel-made Ware spindle bottles have been recovered from the same fillings (D'Agostino, Orsi 2018: fig. 6).<sup>47</sup> This pottery type, which is characterized by very fine and compact fabric, bright orange colour and well-levigated surface, is thought to be a non-local production in the Central Anatolian area where, although appearing since the beginning of the 15<sup>th</sup> century, it seems to be typical of contexts dating from 14<sup>th</sup> and 13<sup>th</sup> centuries BC.

As for many other contexts from Area A-Building II (Figs. 72-74) and Area D-Building III (Figs. 98-100), intrusive handmade sherds in red slip or geometric painted ware from earlier periods are abundant also in the burnt and ashy fillings from the Area C (Fig. 115).

**Chart 7:** Uşaklı Höyük 2013-2015. Materials recovered in Area C

Year	Area	Square	Stratigraphic Unit	Diagnostic Potsherds (Number)	Generic Potsherds (Number)	Potsherds Total (Number)	Slags (Weight in Kg)	Roof Tiles (Weight in Kg)
2014	C	M18 C2-4	S	51	128	179	0.082	
2014	C	M17 C3	4	34	92	126		
2014	C	M17 C3	7	3		3		
2014	C	M17 C4	8	33	57	90	0.083	
2014	C	M17 C4	10		2	2		
2014	C	M17 C4	15	9	37	46		

<sup>44</sup> Additional and more substantial evidence of occupation during the early stages of the Iron Age, however, has been gathered in the course of the last two excavation seasons (2016 and 2017) in the Area D, where a collection of typical Early Iron Age potsherds was uncovered. The results of the 2016 and 2017 excavations will be the object of future reports.

<sup>45</sup> In the contexts of the Upper City of Boğazköy, Type T1 is mostly widespread in period 2. Only a minor percentage, instead, derives from period 3 (Müller-Karpe 1988: 61).

<sup>46</sup> See Müller-Karpe 1988: pl. 32, type S2b; Schoop 2003b: fig. 4: 4.

<sup>47</sup> For a detailed description of the ware, which in terms of Uşaklı Höyük ceramic registration code is registered as *Orange Fine Ware*, see D'Agostino, Orsi 2015: 69-70.

Year	Area	Square	Stratigraphic Unit	Diagnostic Potsherds (Number)	Generic Potsherds (Number)	Potsherds Total (Number)	Slags (Weight in Kg)	Roof Tiles (Weight in Kg)
2014	C	M17 C4	17	5	9	14		
2014	C	M17 C4	18	20	26	46		
2014	C	M17 C4	20	8	13	21		
2014	C	M17 C4	22	15	40	55	0.005	
2014	C	M17 C4	23A	61	141	202	0.060	
2014	C	M17 C4	23B	20	117	137	0.193	
2014	C	M17 C4	24	10	28	38	0.112	
2014	C	M17 C4	25	4	9	13		
2014	C	M17 C4	26	8	12	20		
2014	C	M17 C4	27	4	8	12		
2014	C	M17 C4	28A-D	38	316	354	0.306	
2014	C	M17 C4	28E	34	117	151	0.695	
2014	C	M17 C4	28I	1	19	20	0.016	
2015	C	M17 C4 - M18 C1	28I+28J-sieve	71	163	234	1.520	
2015	C	M17 C4 - M18 C1	28IJ+28IJ-sieve	48	146	194	0.555	
2014	C	M17 C4	28J	4	24	28		
2014	C	M18 C1-2	32	5	3	8		
2014	C	M18 C2	33	14	51	65		
2015	C	M17 C4 - M18 C1-2	33	139	293	432	0.391	
2014	C	M18 C2	34	23	116	139	0.456	
2014	C	M18 C2	35	10	16	26		
2014	C	M18 C2	36	26	75	101	0.051	
2015	C	M17 C4 - M18 C1	38A	38	27	65		
2015	C	M17 C4 - M18 C1	38B	41	59	100		
2014	C	M18 C1-2	39A	16	51	67	0.106	
2015	C	M17 C4 - M18 C1	39A	83	194	277	0.005	
2014	C	M18 C1-2	39B	5	16	21	0.016	
2015	C	M17 C4 - M18 C1	39B	140	417	557	0.108	
2014	C	M18 C2	40	2	6	8		
2015	C	M17 B3-4 - M18 B1-4	43	107	175	282	0.021	0.190
2015	C	M17 B3	44	11	4	15		
2015	C	M17 B4 - M18 B1-2	46	93	144	237	0.090	
2015	C	M17 B4 - M18 B1-2	47	134	274	408		
2015	C	M17 B4 - M18 B1	48	30	65	95	0.080	
2015	C	M18 B3	53	59	107	166	0.014	
2015	C	M18 B2-3	54	48	79	127	0.072	
2015	C	M18 B1	55	4	19	23		
2015	C	M18 B3-4	56	11	21	32		
2015	C	M18 C2-3	67	1	11	12		
2015	C	M17 B4 - M18 B1	68	35	63	98		
2015	C	M18 B1	69	22	48	70		
2015	C	M18 B1	70	126	255	381	0.004	
2015	C	M18 B2	74	1		1		
2015	C	M18 C1-2	77	2	9	11		
2015	C	M18 C1-2	78	175	477	652	0.571	
2015	C	M18 C1-2	79	73	261	334	1.609	
2015	C	M18 C1-2	80	58	158	216	0.129	
2015	C	M18 C1-2	82	1	6	7		

**Chart 8:** Uşaklı Höyük 2013-2015. Qualification of potsherds recovered in Area C

Year	Area	Square	Stratigraphic Unit	Common Ware (Weight in Kg)	Storage Ware (Weight in Kg)	Kitchen Ware (Weight in Kg)	Fine Ware (Weight in Kg)	Ceramic Total (Weight in Kg)
2014	C	M18 C3	S	5.40	0.53	0.83		6.76
2014	C	M17 C3	4	3.01	0.79	0.64		4.45
2014	C	M17 C3	7	0.03	0.25	0.46		0.73
2014	C	M17 C4	8	1.52	0.33	0.00		1.86
2014	C	M17 C4	10	0.05		0.00		0.05
2014	C	M17 C4	15	1.09	0.16	0.21		1.46
2014	C	M17 C4	17	0.50		0.05		0.55
2014	C	M17 C4	18	1.07		0.33		1.40
2014	C	M17 C4	20	0.71	0.13	0.02		0.86
2014	C	M17 C4	22	0.92		0.57		1.49
2014	C	M17 C4	23A	3.98	0.50	1.29		5.77
2014	C	M17 C4	23B	2.20	0.40	0.85		3.45
2014	C	M17 C4	24	0.85		0.14		0.99
2014	C	M17 C4	25	0.41		0.02		0.43
2014	C	M17 C4	26	0.28		0.06		0.34
2014	C	M17 C4	27	0.24		0.14		0.38
2014	C	M17 C4	28A-D	8.16	1.47	1.96	0.008	11.59
2014	C	M17 C4	28E	4.12	0.62	1.32	0.013	6.07
2014	C	M17 C4 - M18 C1	28I	0.53				0.53
2015	C	M17 C4 - M18 C1	28I+28J-sieve	5.95		0.54		6.48
2015	C	M17 C4 - M18 C1	28I+28J-sieve	5.77		0.33	0.024	6.13
2014	C	M17 C4	28J	1.16		0.25		1.41
2014	C	M18 C1-2	32	0.47		0.02		0.49
2014	C	M18 C1-2	33	1.35		0.43		1.78
2015	C	M17 C4 - M18 C1-2	33	12.76	1.06	1.68	0.143	15.64
2014	C	M18 C2	34	2.77	1.12	0.62		4.51
2014	C	M18 C2	35	1.11		0.14		1.25
2014	C	M18 C2	36	2.33	0.11	0.40	0.007	2.84
2015	C	M17 C4 - M18 C1	38A	3.37		0.60	0.023	3.99
2015	C	M17 C4 - M18 C1	38B	5.38		0.43		5.80
2014	C	M18 C1-2	39A	1.90	0.29	0.37		2.56
2015	C	M17 C4 - M18 C1	39A	7.81	0.42	0.94	0.035	9.21
2014	C	M18 C1-2	39B	0.50		0.17		0.67
2015	C	M17 C4 - M18 C1	39B	16.56	0.34	1.87	0.03	18.80
2014	C	M18 C2	40	0.13		0.03		0.16
2015	C	M17 B3-4 - M18 B1-4	43	9.38	2.45	0.48	0.060	12.37
2015	C	M17 B3	44	0.82		0.23		1.06
2015	C	M17 B4 - M18 B1-4	46	8.32	1.71	0.98		11.01
2015	C	M17 B4 - M18 B1-2	47	12.22	1.67	1.44	0.320	15.65
2015	C	M17 B4 - M18 B1-2	48	2.47	0.18	0.35		3.00
2015	C	M18 B3	53	5.55	0.86	0.24		6.65
2015	C	M18 B2-3	54	3.76	0.42	0.98	0.01	5.18
2015	C	M18 B1	55	0.60				0.60
2015	C	M18 B4	56	1.84			0.03	1.87
2015	C	M18 C2-3	67	0.42		0.04		0.46
2015	C	M17 B4 - M18 B1	68	2.78	0.26	0.80	0.067	3.91
2015	C	M18 B1	69	2.39	0.44	0.55	0.012	3.38
2015	C	M18 B1	70	12.98	0.88	2.42	0.029	16.30



Year	Area	Square	Stratigraphic Unit	Common Ware (Weight in Kg)	Storage Ware (Weight in Kg)	Kitchen Ware (Weight in Kg)	Fine Ware (Weight in Kg)	Ceramic Total (Weight in Kg)
2015	C	M18 B2	74	0.05				0.05
2015	C	M18 C1-2	77	0.48				0.48
2015	C	M18 C1-2	78	15.18	1.36	1.26	0.05	17.836
2015	C	M18 C1-2	79	6.62	0.56	0.58	0.01	7.77
2015	C	M18 C1-2	80	4.21	0.48	0.32		5.01
2015	C	M18 C1-2	82	0.33				0.33

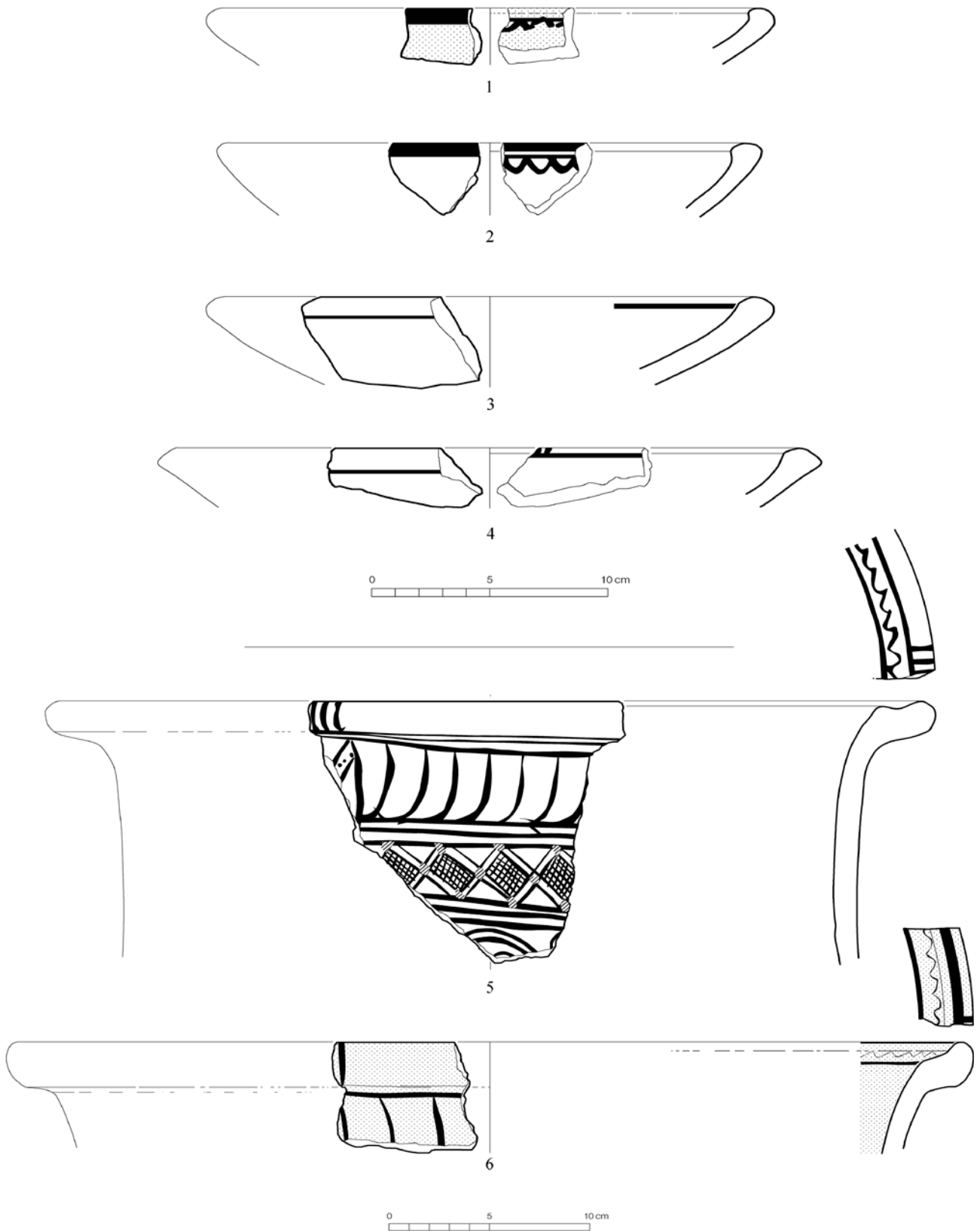

Fig. 101: Area C: Selection of Middle-Iron Age Painted sherds (SU 38 and 39)



**Fig. 102:** Area C: Selection of Painted sherds (SU 33)



**Fig. 103:** Area C: Detail of a spout in Painted Ware (SU 33)



**Fig. 104:** Area C: Detail of a carinated handle in Painted Ware (SU 33)



**Fig. 105:** Area C: Detail of a Painted Ware sherd with *silhouette* motive (or *Alişar IV style*) (SU 33)



**Fig. 107:** Area C: Detail of a coarse plate with string impression on the rim from the ashy and burnt heart layers (SU 38b)

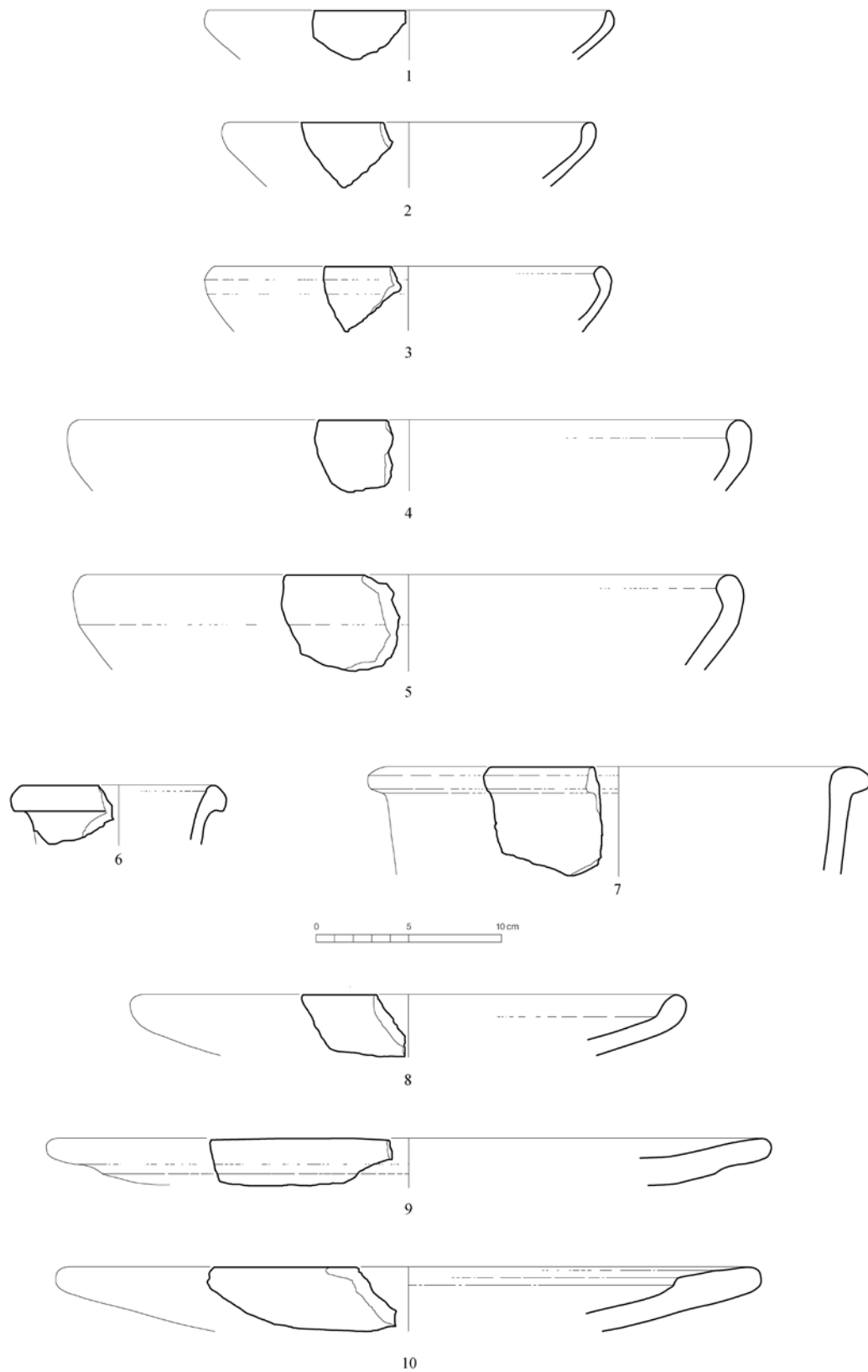

**Fig. 106:** Area C: Selection of typical Late Bronze Age Plain, Drab Ware sherds and coarse plates from the ashy and burnt heart layers



**Fig. 108:** Area C: Selection of Late Bronze Age Common Ware from the ashy and burnt heart layers (SU 28i-interface j)



**Fig. 109:** Area C: Detail of a coarse plate (SU 28i-interface j)



**Fig. 111:** Area C: A combusted slag from the ashy and burnt heart layers (SU 28e)



**Fig. 110:** Area C: Selection of Red Slip Ware, Plain Ware and Coarse plates sherds from the ashy and burnt heart layers (SU 28e)

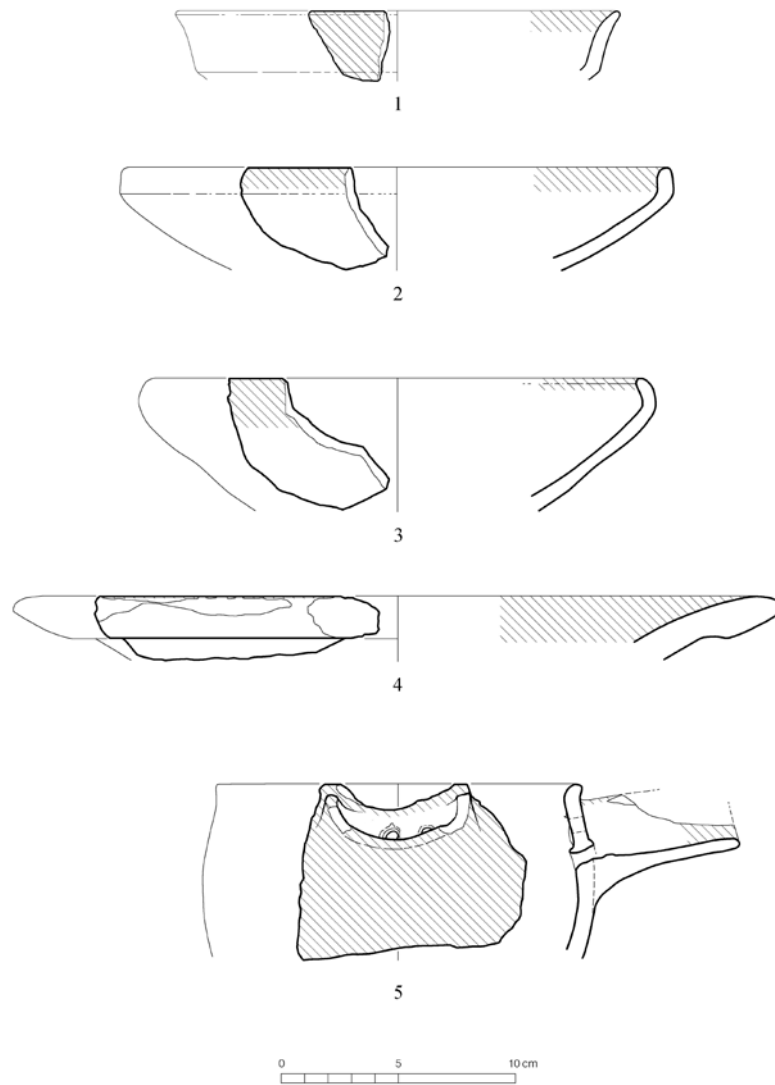

**Fig. 112:** Area C: Selection of Red Slip Ware ceramic types from the ashy and burnt heart layers (SU 28)

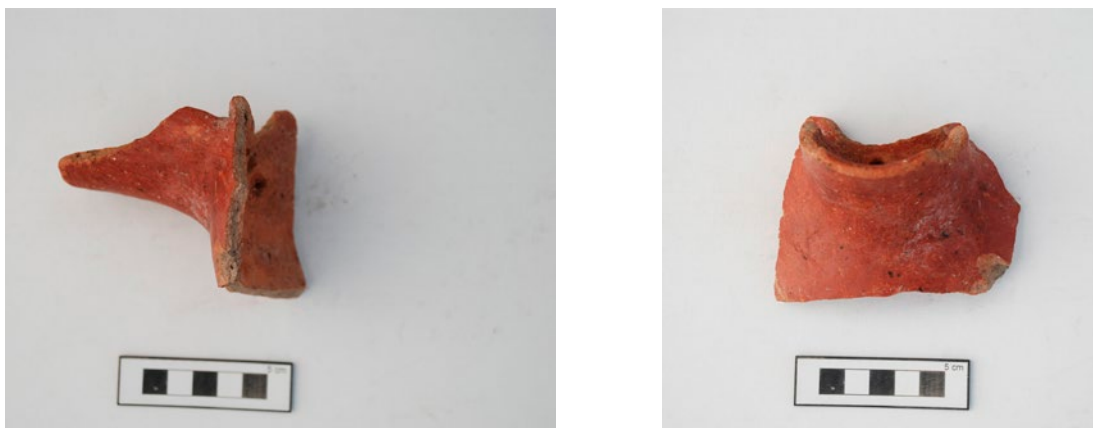

**Fig. 113:** Area C: Detail of a Red Slip Ware teapot (SU 28i)



**Fig. 114:** Area C: Selection of Red Slip Ware samples from the ashy and burnt heart layers (SU 39a)



**Fig. 115:** Area C: Selection of Handmade Red Slip Ware sherds (SU 33)

### The Area B and Area A J18A1

Despite the presence of sparse ceramic examples from earlier periods, the vast majority of the potsherds from Area B-Building I and from excavations in the square J18A1, on the western appendix of Area A, belongs to the later periods (Fig. 116): in the absence of other clear internal evidence, the evaluation of a precise dating is challenging, but preliminary comparisons with ceramic inventories from nearby sites point to the Hellenistic and Roman periods. To the Hellenistic period, in particular, should be dated a series of examples characterized by a particularly fine paint in a purple colour. A large number of fragments of roof tiles, some of which almost entirely preserved, were found in both areas, and particularly in square J18A1.

**Chart 9:** Uşaklı Höyük 2013-2015. Materials recovered in Area A-Sector J18 A1

Year	Area	Square	Stratigraphic Unit	Diagnostic Potsherds (Number)	Generic Potsherds (Number)	Potsherds Total (Number)	Slags (Weight in Kg)	Roof Tiles (Weight in Kg)
2014	A	J18 A1	103	28	70	98	0.029	18.36
2014	A	J18 A1	107	49	198	247	1.333	34.57
2014	A	J18 A1	108	40	146	186	0.057	1.58
2014	A	J18 A1	109	6	18	24		0.36
2014	A	J18 A1	115	2	11	13		0.09
2014	A	J18 A1	116	4	30	34		0.05
2014	A	J18 A1	117	9	53	62	0.005	3.28
2014	A	J18 A1	121	11	94	105	0.014	46.80

**Chart 10:** Uşaklı Höyük 2013-2015. Qualification of potsherds recovered in Area A-Sector J18 A1

Year	Area	Square	Stratigraphic Unit	Common Ware (Weight in Kg)	Storage Ware (Weight in Kg)	Kitchen Ware (Weight in Kg)	Fine Ware (Weight in Kg)	Ceramic Total (Weight in Kg)
2014	A	J18 A1	103	1.31	0.25	0.27	0.01	1.84
2014	A	J18 A1	107	4.52	3.30	0.82	0.01	8.65
2014	A	J18 A1	108	2.15	3.97	0.98	0.052	7.14
2014	A	J18 A1	109	0.47		0.16		0.64
2014	A	J18 A1	115	0.24		0.03		0.27
2014	A	J18 A1	116	0.39	0.10	0.33		0.82
2014	A	J18 A1	117	1.86	3.84	0.24		5.94
2014	A	J18 A1	121	1.41	0.45	0.21		2.07

**Chart 11:** Uşaklı Höyük 2013-2015. Materials recovered in Area B

Year	Area	Square	Stratigraphic Unit	Diagnostic Sherds (Number)	Generic Sherds (Number)	Total Sherds (Number)	Slags (Weight in Kg)	Roof Tiles (Weight in Kg)
2015	B	H19 C1	5	2	12	14		
2015	B	H18 C4 - H19 C1	7	35	54	89		4.674
2015	B	H18 C4	8	24	81	105		4.016
2015	B	H18 C4 - H19 C1	12	27	104	131		
2015	B	H19 C1	16	13	38	51	0.095	4.974



Year	Area	Square	Stratigraphic Unit	Diagnostic Sherds (Number)	Generic Sherds (Number)	Total Sherds (Number)	Slags (Weight in Kg)	Roof Tiles (Weight in Kg)
2015	B	H18 C4 – H19 C1	17	52	231	283	0.032	
2015	B	H19 C1	18	4	10	14		
2015	B	H18 C4 - H19 C1	19	40	101	141		0.307
2015	B	H18 C4 - H19 C1	20	19	69	88		
2015	B	H18 C4 - H19 C1	23		3	3	0.004	
2015	B	H18 C4 - H19 C1	24	3	6	9		
2015	B	H19 C1	25	21	66	87		

**Chart 12:** Uşaklı Höyük 2013-2015. Qualification of potsherds recovered in Area B

Year	Area	Square	Stratigraphic Unit	Common Ware (Weight in Kg)	Storage Ware (Weight in Kg)	Kitchen Ware (Weight in Kg)	Fine Ware (Weight in Kg)	Ceramic Total (Weight in Kg)
2015	B	H19 C1	5	0.16	0.46	0.02	0.004	0.65
2015	B	H18 C4 - H19 C1	7	4.25	0.25	0.01	0.08	4.59
2015	B	H18 C4	8	2.05		0.31	0.02	2.38
2015	B	H18 C4 - H19 C1	12	5.62	0.25	0.88	0.082	6.84
2015	B	H19 C1	16	0.74		0.04	0.033	0.81
2015	B	H18 C4 – H19 C1	17	4.96	0.21	0.17	0.020	5.35
2015	B	H19 C1	18	0.43				0.43
2015	B	H18 C4 - H19 C1	19	3.43		0.51	0.04	3.97
2015	B	H18 C4 - H19 C1	20	1.56		0.34	0.005	1.90
2015	B	H18 C4 - H19 C1	23	0.33				0.33
2015	B	H18 C4 - H19 C1	24	0.10				0.10
2015	B	H19 C1	25	1.58		0.01	0.004	1.59



**Fig. 116:** Area B: Selection of Fine Ware with orange slipped surface (SU 12)

### *Acknowledgements*

We express our sincere gratitude to the Directorate of Cultural Heritage and Museums, to the Director of the Excavations and Surveys Department, Melik Ayaz, for the invaluable support and constant advice. We remain deeply indebted to the Yozgat Director of Culture and Tourism, Lütfi Ibiş, and to the director of the Yozgat Museum, Hasan Şenyurt, and the staff of the Museum; to the Sorgun District Governor, the İlçe Kaymakam, Levent Kiliç, and the Mayor of Sorgun, Ahmet Şimşek, who generously offered their kind support to the field work at Uşaklı Höyük. Without the committed and wise action of Dr. Metin Kayaçağlayan our work would not have reached its goal in the 2013-2015 campaigns. We warmly thank the director of the Italian Institute of Culture at Ankara, Gianluca Biscardi; we owe to his commitment some of the furniture of the mission's house acquired from the then closed Institute.

In 2013 the excavations were a joint project of the University of Florence and the Museum of Yozgat, under the co-direction of Stefania Mazzoni and Hasan Şenyurt, director of the Yozgat Museum, represented by Gülüzar Kaçmaz, with the participation of Çigdem Maner of the Koç University, and started on July 10th. In 2014 the permit to excavate was delivered to Florence University, under the direction of Stefania Mazzoni, with Gülden Ekmen (Bülent Ecevit University, İncivez, Zonguldak) and Anacleto D'Agostino (University of Pisa) as deputy directors. In 2014 and 2015 our representatives were Özgür Hacikerimli (Kahramanmaraş Museum) and Ertan Yılmaz (Kaman Museum) and in 2014 Mustafa Günaydın was appointed as guardian of the site and the Mission House.

While the study of the epigraphic materials was carried out by the Hittitologists Franca Pecchioli Daddi, Giulia Torri, Carlo Corti, Alfonso Archi, the field and filing activities were coordinated by Valentina Orsi (University of Siena), and carried out by the archaeologists Giuseppe Minunno, Melissa Ricetti, Silvana Rubanu, Chiara Spinazzi Lucchesi, Francesca Simi, Margherita Dallai, Marta Aquilano, and the students Giuseppe Mancuso, Giuseppe Marchese, Vincenzo Ippolito, Guido Della Lena Guidiccioni, Federico Devoto, Raffaele Ranieri, Else Bracali, Maria Francesca Pullia, Clizia Murgia, Livio Warbinek, Diletta D'Antoni, Anna Maria Nardon, Margherita Forni, Alessandro Salotti, Iolanda Cacoza, Caterina Fantoni, Margherita Carletti, Anete Mezmaca and Anne Laure Lardièrre. In 2014 the students of the History Department of the Bozok University of Yozgat tutored by Aslı Kahraman Çınar took part in the field activities: Adnan Güzel, Kübra Yildirim, Ali Yildirim, Emre Çevik, Tolgahan Arun, Fatih Güleç, Ertuğrul Sözügeçer, Ali Ataş, Nasir Şen, Yasemin Yurt, Hümeyra Özkan, Merve Ayaz, Fatma Yikici, Duygu Özkan, Tolga Mehmet Aksay.

Financial support for the campaigns has been granted by the Ministero degli Affari Esteri (DGSP VI), Ministero dell'Istruzione, dell'Università e della Ricerca (PRIN 2009), Fondazione OrMe, Oriente Mediterraneo and Università di Firenze.

### *Bibliography*

- Akar M. 2017, Pointed Juglets as an International Trend in Late Bronze Ritual Practices: A View from Alalakh. In Ç. Maner, M.T. Horowitz and A.S. Gilbert (eds.), *Overturing Certainties in Near Eastern Archaeology. A Festschrift in Honor of K. Aslıhan Yener*, Leiden-Boston: 1-24.
- Archi A., Corti C., Pecchioli Daddi, F. Torri, G. 2015, Epigraphic findings, in S. Mazzoni and F. Pecchioli Daddi (eds.), *The Uşaklı Höyük Survey Project (2008-2012). A final report*, Studia Asiana 10, Firenze: 349-363.
- Arnhold S. 2009. *Das hethitische Gebäude E auf der Akropolis von Kuşaklı*, Kuşaklı-Sarissa Band 4, Rahden/Westf.
- Bittel K. 1970. *Hattusha. The Capital of the Hittites*, New York.
- Boehmer R. M. 1972. *Die kleinfunde von Boğazköy. Aus den grabungskampagnen 1931-1939 und 1952-1969*, Wissenschaftliche Veröffentlichung der Deutschen Orient-Gesellschaft 87, Boğazköy-Hattuša: Ergebnisse der Ausgrabungen VII, Berlin.
- Bossert E.-M., 2000, *Die Keramik phrygischer zeit von Boğazköy: Funde aus den Grabungskampagne 1906, 1907, 1911, 1921, 1931-1939 und 1952-1960*, Boğazköy-Hattuša: Ergebnisse der Ausgrabungen XVIII, Mainz am Rhein.

- Brysbaert A. 2008, *The power of technology in the Bronze age eastern mediterranean. The case of the painted plaste*, Monograph in Mediterranean Archaeology, London.
- D'Agostino A., Orsi V. 2015, The archaeological survey, in S. Mazzoni and F. Pecchioli Daddi (eds.), *The Uşaklı Höyük Survey Project (2008-2012). A final report*, Studia Asiana 10, Firenze: 35-343.
- D'Agostino A., Orsi V. 2016, Researches at Uşaklı Höyük (Central Turkey): survey, surface scraping and first digging operations, in R.-A. Stucky, O. Kaelin, H.-P. Mathys. (eds.), *Proceedings of the 9th International Congress on the Archaeology of the Ancient Near East. June 12, 2014: Universität Basel (Switzerland)*, Wiesbaden: 333-346.
- D'Agostino A., Orsi V. 2018, The 2013-2015 excavation seasons at Uşaklı Höyük (Central Turkey)', in B. Horejs, C. Schwall, V. Müller, M. Luciani, M. Ritter, M. Guidetti, R.-B. Salisbury, F. Höflmayer and T. Bürge (eds), *Proceedings of the 10th International Congress on the Archaeology of the Ancient Near East, 25-29 April, Vienna, Vol. 2*, Wiesbaden: 485-496.
- D'Alfonso L., Gorrini M.-E., Mora C. 2016, The Early Iron Age and the Hellenistic Period at Kınık Höyük, South Central Anatolia. Report of the 5th Campaign (2015), *Athenaeum* 104/2: 598-612.
- Fischer F. 1963, *Die hethitische Keramik von Boğazköy*, Wissenschaftliche Veröffentlichung der Deutschen Orient-Gesellschaft 75, Boğazköy-Hattuša: Ergebnisse der Ausgrabungen IV, Berlin.
- Genz H. 2000, Die Eisenzeit in Zentralanatolien im Lichte der keramischen Funde vom Büyükkaya in Boğazköy/Hattuša, *TÜBA-AR* III: 35-54.
- Genz H. 2001, Iron Age pottery from Çadır Höyük, *Anatolica* 27: 159-70.
- Genz H. 2003, The Early Iron Age in Central Anatolia, in B. Fischer, H. Genz, É. Jean, K. Köroğlu (eds.), *Identifying Changes: The Transition from Bronze to Iron Ages in Anatolia and its Neighbouring Regions, Proceedings of the International Workshop, Istanbul, November 8-9, 2002*, Istanbul: 179-191.
- Genz H. 2004, *Büyükkaya. I. Die Keramik der Eisenzeit. Funde aus den Grabungskampagnen 1993 bis 1998*, Boğazköy-Hattuša: Ergebnisse der Ausgrabungen XXI, Mainz.
- Genz H. 2005, Thoughts on the origin of the Iron Age pottery traditions in central Anatolia, in A. Çilingiroğlu, G. Darbyshire (eds.), *Anatolian Iron Ages 5. Proceedings of the Fifth Anatolian Iron Ages Colloquium held at Van, 6-10 August 2001*, London: 75-84.
- Genz H. 2006, Die eisenzeitliche Besiedlung im Bereich der Grabungen am mittleren Büyükkale-Nordwesthang 1998-2000, in J. Seeher (ed.), *Ergebnisse der Grabungen an den Osteichen und am mittleren Büyükkale-Nordwesthang in den Jahren 1996-2000*, Boğazköy-Berichte 8: 98-158.
- Genz H. 2007, The Late Iron Age occupation on the northwest slope at Boğazköy, in A. Çilingiroğlu, A. Sagona (eds.), *Anatolian Iron Ages 6. The Proceedings of the Sixth Anatolian Iron Ages Colloquium held at Eskişehir, 16-20 August 2004*, Leuven, Paris, Dudley: 135-151.
- Genz H. 2011, The Iron Age in Central Anatolia, in G.-R. Tsatskheladze (ed.), *The Black Sea, Greece, Anatolia and Europe in the First Millennium BC*, Colloquia Antiqua 1, Leuven, Paris, Walpole MA: 331-368.
- Glatz C. 2009, Empire as Network: Spheres of Material Interaction in Late Bronze Age Anatolia, *Journal of Anthropological Archaeology* 28: 127-41.
- Hachmann R. 1957, Prähistorische Funde von Cıradere, in K. Bittel, R. Naumann, Th. Beran, R. Hachmann, R.-G. Kurth 1957 (eds.), *Bogazkoy III, Funde aus den Grabungen 1952- 1955*, Ausgrabungen der Deutschen Orient-Gesellschaft und des Deutschen Archäologischen Instituts, Abhandlungen der Deutschen Orient-Gesellschaft 2, Berlin: 62-66.
- Kealhofer L., Grave P., Genz H., Marsh B. 2009, Post Collapse: The Re-Emergence of Polity in Iron Age Boğazköy, Central Anatolia, *Oxford Journal of Archaeology* 28(3): 275-300.
- Kealhofer L., Grave P., Marsh B., Steadman S.-R., Gorny R.-L., Summers G.-D. 2010, Patterns of Iron Age interaction in central Anatolia: three sites in Yozgat province, *Anatolian Studies* 60: 71-92.
- Kealhofer L., Grave P. 2011, The Iron Age on the Central Anatolian Plateau, in S.-R. Steadman and G. McMahon (eds), *The Oxford Handbook of Ancient Anatolia*, Oxford: 415-442.
- Koşay H.-Z., Akok M. 1966, *Türk Tarih Kurumu tarafından yapılan Alaca Höyük kazisi. 1940-1948 deki çalışmalara ve kesiflere ait ilk rapor / Ausgrabungen von Alaca Höyük. Vorbericht über die Forschungen und Entdeckun-*

- gen von 1940-1948*, Türk Tarih Kurumu Yayınlarından V. Seri – Sa. 6, Ankara.
- Krause K. 1940, *Boğazköy, Tempel V. Ein Beitrag zum Problem der hethitischen Baukunst*, Istanbulischer Forschungen, Forschungen, Bd. 11, Keilschrifturkunden aus Boğazköy, Berlin.
- Matsumura K. 2005, Die eisenzeitliche Keramik in Zentralanatolien aufgrund der Grundlage der Ausgrabung von Kaman-Kalehöyük, PhD Dissertation, Freie Universität Berlin.
- Matsumura K. 2008, The Early Iron Age in Kaman-Kalehöyük: the search for its roots, in D. Bonatz, R.-M. Czi-  
chon, F.-J. Kreppner (eds.), *Fundstellen. Gesammelte Schriften zur Archäologie und Geschichte Alt Vorderasiens ad  
honorem Hartmut Kühne*, Wiesbaden: 41-50.
- Mazzoni S. 2015, Uşaklı Höyük and its hinterland. The 2008-2012 Survey, in S. Mazzoni and F. Pecchioli Daddi  
(eds), *The Uşaklı Höyük Survey Project (2008-2012). A Final Report*, Firenze: 1-17.
- Mazzoni S., D'Agostino A. 2015, Researches at Uşaklı Höyük (Central Anatolian Plateau), in S.-R. Steadman, G.  
MacMahon (eds.), *The Archaeology of Anatolia: Current Work (2013-2014)*, Cambridge: 149-179.
- Mazzoni S., D'Agostino A., Orsi V. 2010, Survey of the archaeological landscape of Uşaklı/Kuşaklı Höyük (Yoz-  
gat), *Anatolica* 36: 111-163.
- Mazzoni S., Pecchioli Daddi F. 2015 (eds.), *The Uşaklı Höyük Survey Project (2008-2012). A Final Report*, Firenze.
- Meriggi P. 1971, Ottavo e ultimo viaggio anatolico, *Oriens Antiquus* 10: 57-60.
- Mielke D.-P. 2006, *Die Keramik vom Westhang. Kuşaklı-Sarissa 2*, Rahden-Westphalia.
- Mielke D.-P. 2010, Kuşaklı und Boğazköy (Türkei) – Zwei Ansätze zur Bearbeitung großer Keramikmengen aus  
hethitischen Kontexten, in B. Horejs, R. Jung, P. Pavúk (eds.), *Analysing Pottery. Processing – Classification –  
Publication*, Bratislava, Slovakia: 187-208.
- Mielke D.-P. 2017, From 'Anatolian' to 'Hittite'. The Development of Pottery in Central Anatolia in the 2nd Mil-  
lennium BC, in A. Schachner (ed.), *Innovation versus Beharrung: Was macht den Unterschied des hethitischen  
Reichs im Anatolien des 2. Jahrtausends v. Chr.*, Byzas 23, Veröffentlichungen des Deutschen Archäologischen  
Instituts Istanbul, Istanbul: 121-144.
- Mitchell St. 1993, *Anatolia. Land, Men, and Gods in Asia Minor. I. The Celts and the Impact of Roman Rule*, Mit-  
ford.
- Mühlenbruch T. 2014, *Hethitische Keramik im Kontext. Das Gebäude B von Kayalıpınar und die Nutzung institu-  
tioneller Gebäude des 2. Jt.s v. Chr. Im ostmediterranen Raum*, Marburger Studien zur Vor- und Frühgeschichte  
26; Kayalıpınar Band 1, Rahden/Westf.
- Müller-Karpe A. 1988, *Hethitische Töpferei der Oberstadt von Hattuša. Ein Beitrag zur Kenntnis spät-großreichs-  
zeitlicher Keramik und Töpferbetriebe unter Zugrundelegung der Grabungsergebnisse von 1978–82 in Boğazköy*,  
Marburg.
- Müller-Karpe A. 2017, *Sarissa. Die Wiederentdeckung einer hethitischen Königsstadt*, Zaberns Bildbände zur  
Archäologie, Darmstadt.
- Müller-Karpe V. 2009, Frühhethitische Keramikfunde, *Mitteilungen der Deutschen Orient Gesellschaft* 141: 200-  
206.
- Neve P. 1983, Die Ausgrabungen in Boğazköy-Hattuša, *Archäologischer Anzeiger* 1983: 427-454.
- Neve P. 1999, *Die Oberstadt von Hattuša. Die Bauwerke I. Die Bebauung im Zentralen Tempelviertel*, Boğazköy-  
Hattuša XVI, Berlin.
- Neve P. 2001, *Die Oberstadt von Hattuša. Die Bauwerke II. Die Bastion des Sphinxtores und die Tempelviertel am  
Königs- und Löwentor*, Boğazköy-Hattuša XVII, Mainz am Rhein.
- Orsi V. 2018, Reading the Late Bronze Age Ceramic Evidence at Uşaklı Höyük (Central Turkey). The Pottery  
from the Area A Test Sounding, *Anatolica* 44: 179-211.
- Orthmann W., 1963, *Frühe Keramik von Boğazköy aus den Ausgrabungen am Nordwesthang von Büyükkale*, Berlin.
- Özgülç T. 1982, *Maşat Höyük II: A Hittite center northeast of Boğazköy*, Türk Tarih Kurumu Yayınlarından, V. Dizi  
– Sa.38a, Ankara.
- Özyar A. 2006, A Prospectus of Hittite Art Based on the Statue of our Knowledge at the Beginning of the 3<sup>rd</sup>  
Millennium AD, in D.-P. Mielke, U.-D. Schoop and J. Seeher (eds.), *Strukturierung und Datierung in der*

- hethitischen Archäologie / Structuring and Dating in Hittite Archaeology*, Byzas 4, Veröffentlichungen des Deutschen Archäologischen Instituts Istanbul, Istanbul: 125-148.
- Parzinger H., Sanz R. 1992, *Die Oberstadt von Hattuša: hethitische Keramik aus dem zentralen Tempelviertel. Funde aus den Ausgrabungen 1982-1987*, Boğazköy- Hattuša: Ergebnisse der Ausgrabungen XV, Berlin.
- Pecchioli Daddi F. 2015, The Economical and Social Structure of a Holy City: the Case of Zippalanda, in A. Müller Karpe, E. Rieken, W. Sommerfeld (eds.), *Saeculum - Gedenkschrift für Heinrich Otten anlässlich seines 100. Geburtstags*, StBoT 58, Wiesbaden: 153-164.
- Pecchioli Daddi F. 2016, Zippalanda and the Cities of Central Anatolia: Economic and Religious Connections, in Š. Velhartická (ed.), *Audias fabulas veteres. Anatolian Studies in Honor of Jana Součková-Siegelova*, Leiden/Boston: 296-308.
- Pecchioli Daddi F., Torri G., Corti C. 2014, The Survey in the Area of Usakli Hoyuk (Yozgat): Archaeologic and Epigraphic Findings, in P. Taracha (ed.), *Proceedings of the Eighth International Congress of Hittitology, Warsaw, 5-9 September 2011*, Warsaw: 671-681.
- Poetto M. 2015, Bulla with Anatolian Hieroglyphs, in S. Mazzoni and F. Pecchioli Daddi (eds.), *The Uşaklı Höyük Survey Project (2008-2012)*, Studia Asiana 10, Firenze: 345-348.
- Powroznik K.-J. 2010, *Die Eisenzeit in Kuşaklı*, Kuşaklı-Sarissa band 5, Rahden/Westf.
- Rice P.-M. 1987, *Pottery Analysis. A Sourcebook*, Chicago and London.
- Sams K. 2012, The new chronology of Gordion and Phrygian Pottery, in C. Brian Rose (ed.), *The Archaeology of Phrygian Gordion, Royal City of Midas*, Gordion Special Studies 7, Museum Monographs 136, Philadelphia: 56-66.
- Schachner A. 2010, Hattusa Kayalardan Şekillendirilmiş Bir Şehir. 1, *Çorum Kazı ve Araştırmalar Sempozyumu*, Çorum: 111-136.
- Schachner A. 2011, *Hattuscha. Auf der Such nach dem sagenhaften Grossreich der Hethiter*, München.
- Schoop U.-D. 2003a, Erste Beobachtungen zum Keramikinventar aus dem Tal vor Sarıkale, in: J. Seeher, Die Ausgrabungen in Boğazköy-Hattuša 2002, *Archäologischer Anzeiger* 2003: 14–20.
- Schoop U.-D. 2003b, Pottery Tradition of the Late Hittite Empire: Problems of Definition, in B. Fischer, H. Genz, É. Jean, K. Köröglü (eds.), *Identifying Changes: The Transition from Bronze to Iron Ages in Anatolia and its Neighbouring Regions, Proceedings of the International Workshop, Istanbul, November 8-9, 2002*, Istanbul: 215-238.
- Schoop U.-D. 2006, Dating the Hittites with Statistics: Ten Pottery Assemblages from Boğazköy-Hattuša, in D.-P. Mielke, U.-D. Schoop and J. Seeher (eds.), *Strukturierung und Datierung in der hethitischen Archäologie*, Byzas 4, Veröffentlichungen des Deutschen Archäologischen Instituts Istanbul, Istanbul: 215-239.
- Schoop U.-D. 2008, Wo steht die Archäologie in der Erforschung der hethitischen Kultur? Schritte zu einem Paradigmenwechsel, in G. Wilhelm (ed.), *Hattuša-Boğazköy. Das Hethiterreich im Spannungsfeld des Alten Orients. 6. Internationales Colloquium der Deutschen Orient-Gesellschaft 22.-24. März 2006, Würzburg*, Wiesbaden: 35-60.
- Schoop U.-D. 2009, Indications of Structural Change in the Hittite Pottery Inventory at Boğazköy-Hattuša, in F. Pecchioli Daddi, G. Torri and C. Corti (eds.), *Central-North Anatolia in the Hittite Period. New Perspectives in Light of Recent Researches (Acts of the International Conference held at the University of Florence, 7-9 February 2007)*, Studia Asiana 5, Roma: 145-167.
- Schoop U.-D. 2011, Hittite pottery: a summary, in H. Genz and D.-P. Mielke (eds.), *Insights into Hittite history and archaeology (Colloquia Antiqua 2)*, Leuven, Paris, Walpole: 241-274.
- Seeher J. 1998, The Early Iron Age Settlement on Büyükkaya, Boğazköy: First Impressions, in N. Tuna, Z. Aktüre, M. Lynch (eds.), *Thracians and Phrygians: Problems of Parallelism*, Ankara: 70-78.
- Seeher J. 2000, Hattuša/Boğazköy'ün Yerleşim Tarihine Yeni Katkılar: Büyükkaya Kazılarında Toplu Bir Bakış, *TÜBA-AR* III: 15-34.
- Steadman R.-S., McMahon G., Ross J.-C., Cassis M., Şerifoğlu T.-E., Arbuckle B.-S., Adcock S.-E., Alpaslan, Roodenberg S., von Baeyer M., Lauricella A.-J. 2015, The 2013 and 2014 Excavation Seasons at Çadır Höyük on the Anatolian North Central Plateau, *Anatolica* 41: 87-123.

- Strobel K. 2002, State Formation by the Galatians of Asia Minor, *Anatolica* 28: 1-46.
- Strobel K. 2009, The Galatians in the Roman Empire. Historical Tradition and Ethnic Identity in Hellenistic and Roman Asia Minor, in T. Derks, N. Roymans (eds.), *Ethnic Constructs in Antiquity. The Role of Power and Tradition*, Amsterdam Archaeological Studies 13, Amsterdam: 117-144.
- Strobel, K., Gerber Ch. 2007, Tavium (Büyüknefes, Provinz Yozgat). Bericht über die Kampagnen 2003-2005, *Istanbul Mitteilungen* 57: 547-621.
- Strobel K., Gerber Ch. 2010, Tavium (Büyüknefes, Provinz Yozgat) und seine Region. Bericht über die Kampagnen 2006-2009, *Istanbul Mitteilungen* 60: 291-338.
- Summers G.-D. 2008, Periodisation and Technology in the Central Anatolian Iron Age. Archaeology, History and Audiences, *Ancient Near Eastern Studies* 45: 202-17.
- Summers G.-D. 2009, Between Urartu and Phrygia. The North-Central Anatolian Plateau in the Iron Age, in H. Sağlamtimur, et al. (eds.), *Studies in Honour of Altan Çilingiroğlu: a life dedicated to Urartu on the shores of the Upper Sea*, Arkeoloji ve Sanat, Istanbul: 657-671.
- Summers G.-D. 2014, East of the Halys: Thoughts on Settlement Patterns and Historical Geography in the Late 2<sup>nd</sup> Millennium and First Half of the First Millennium B.C, in H. Bru, G. Labarre (eds.), *L'Anatolie des peuples, des cités et des cultures* (II<sup>e</sup> millénaire av. J.-C. – V<sup>e</sup> siècle ap. J.-C.), Paris: 41-51.
- Summers M.-E.-F., Summers G.-D., Ahmet K. 1995, The Regional Survey at Kerkenes Dağ: an Interim Report on the Seasons of 1993 and 1994, *Anatolian Studies* 45: 43-68.
- Torri G. 2015, Epigraphic evidence about Zippalanda, in S. Mazzoni and F. Pecchioli (eds.), *The Uşaklı Höyük Survey Project (2008-2012). A final report*, Studia Asiana 10: 365-367.
- von der Osten H.-H. 1937, *The Alishar Hüyük Seasons of 1930-32*, Part II, Oriental Institute Publications XXIX, Chicago.
- von Rügen C., Jungfleisch J. 2017, Incorporating the Other: A Transcultural Perspective on some Wall Painting Fragments from Hattusha, in A. Schachner (ed.), *Innovation versus Beharrung: Was macht den Unterschied des hethitischen Reichs im Anatolien des 2. Jahrtausends v. Chr.? Internationaler Workshop zu Ehren von Jürgen Seeher - Istanbul, 23.-24. Mai 2014*, Byzas 23, Veröffentlichungen des Deutschen Archäologischen Instituts Istanbul, Istanbul: 61-83.