

STUDIA ASIANA

- 10 -

STUDIA ASIANA

Collana fondata da Alfonso Archi, Onofrio Carruba e Franca Pecchioli Daddi

Comitato Scientifico

Alfonso Archi, Fondazione OrMe – Oriente Mediterraneo

Amalia Catagnoli, Università degli Studi di Firenze

Anacleto D'Agostino, Università di Pisa

Rita Francia, Sapienza – Università di Roma

Gianni Marchesi, Alma Mater Studiorum – Università di Bologna

Stefania Mazzoni, Università degli Studi di Firenze

Valentina Orsi, Università degli Studi di Firenze

Marina Pucci, Università degli Studi di Firenze

Elena Rova, Università Ca' Foscari – Venezia

Giulia Torri, Università degli Studi di Firenze

The Uşaklı Höyük Survey Project (2008-2012)

A final report

Edited by
STEFANIA MAZZONI, FRANCA PECCHIOLI DADDI

FIRENZE UNIVERSITY PRESS

2015

The Uşaklı Höyük Survey Project (2008-2012) : a final report /
edited by Stefania Mazzoni, Franca Pecchioli Daddi. – Firenze
: Firenze University Press, 2015.
(Studia Asiana ; 10)

<http://digital.casalini.it/9788866559023>

ISBN 978-88-6655-901-6 (print)
ISBN 978-88-6655-902-3 (online)

Graphic design: Alberto Pizarro Fernández, Pagina Maestra
Front cover photo: View of Uşaklı Höyük, from North (August 2009)

The volume was published with the contribution of *Ente Cassa di Risparmio di Firenze*.



P. Watson edited the English text, N. Birgen translated the summaries in Turkish

Picture and illustration credits

The pictures of sites, landscapes, objects and sherds in plates 1-4, 8-43 were taken by A. D'Agostino a part Pl. 3.1a, 3.2, and 13.5 taken by S. Mazzoni, Pl. 3.3 taken by F. and G. Summers Pl. 42 and 43.1 taken by S. Martelli; those in plates 5-7 were taken by R. Salvini.

Line drawings of ceramic sherds and objects are by S. Martelli. Illustrations, graphic visualization and GIS data processing concerning the collecting units, scattering of sherds and archaeological materials have been drawn by S. Bernardoni and R. Trojanis – Studio KULLA (studiokulla.com); the topographic plan used in those visualizations has been realised by E. Mariotti, the geophysics plots by G. Carpentiero; A. D'Agostino and V. Orsi have elaborated the ceramics database.

Composition of all plates and figures of the volume are by A. D'Agostino.

Peer Review Process

All publications are submitted to an external refereeing process under the responsibility of the FUP Editorial Board and the Scientific Committees of the individual series. The works published in the FUP catalogue are evaluated and approved by the Editorial Board of the publishing house. For a more detailed description of the refereeing process we refer to the official documents published on the website and in the online catalogue of the FUP (www.fupress.com).

Firenze University Press Editorial Board

G. Nigro (Co-ordinator), M.T. Bartoli, M. Boddi, R. Casalbuoni, C. Ciappei, R. Del Punta, A. Dolfi, V. Fargion, S. Ferrone, M. Garzaniti, P. Guarnieri, A. Mariani, M. Marini, A. Novelli, M.C. Torricelli, M. Verga, A. Zorzi.

This work is licensed under a Creative Commons Attribution 4.0 International License
(CC BY 4.0: <http://creativecommons.org/licenses/by/4.0/legalcode>).

CC 2015 Firenze University Press
Università degli Studi di Firenze
Firenze University Press
Borgo degli Albizi, 28 50122
www.fupress.com
Printed in Italy

CONTENTS

| | |
|--|----|
| PREFACE | IX |
| <i>Stefania Mazzoni</i> | |
| UŞAKLI HÖYÜK AND ITS HINTERLAND THE 2008-2012 SURVEY | 1 |
| <i>Stefania Mazzoni</i> | |
| 1. Introduction: methodology and programme of the 2008-2012 operations | 2 |
| 2. The name of the site | 3 |
| 3. Uşaklı Höyük and its hinterland | 3 |
| 3.1 The setting: the river and the plain | 3 |
| 3.2 The survey in the territory | 4 |
| 3.2.1 The southern sector | 4 |
| 3.2.2 The northern sector | 5 |
| 3.3 Descriptive list of sites and archaeological features | 5 |
| 4. Surveying the site | 6 |
| 4.1 Morphology and surface features | 6 |
| 4.2 The geophysical survey | 7 |
| 4.3 Interpreting the buried structures | 8 |
| 5. First explorations on the site | 9 |
| 6. The settlement and its historical context | 10 |
| References | 12 |
| Figures | 15 |
| FIRST RESULTS FROM TOPOGRAPHIC AND GEOLOGICAL MAPPING IN THE AREA OF UŞAKLI HÖYÜK | 19 |
| <i>Riccardo Salvini, Maria Cristina Salvi, Alice Cartocci, Eleonora Magnani</i> | |
| 1. Introduction | 19 |
| 2. Materials and Methods | 21 |
| 2.1 GPS survey | 21 |
| 2.2 Images orientation and stereorestitution | 21 |
| 2.3 Production of digital terrain model and orthoimages | 22 |
| 2.4 Topographic mapping | 22 |
| 2.5 Preliminary geological mapping | 22 |
| 3. Results and discussion | 22 |
| 4. Conclusions | 23 |
| Acknowledgements | 24 |
| References | 24 |
| INFORMATION FROM THE SURFACE. TOPOGRAPHICAL SURVEY AT UŞAKLI HÖYÜK | 29 |
| <i>Emanuele Mariotti</i> | |
| 1. Foreword | 29 |
| 2. The topographic survey at Uşaklı Höyük | 30 |
| 2.1 Methodology and purposes | 30 |
| References | 31 |
| Figures | 32 |

| | |
|---|-----|
| THE ARCHAEOLOGICAL SURVEY: METHODS AND MATERIALS | 35 |
| <i>Anacleto D'Agostino, Valentina Orsi</i> (with the collaboration of Guido della Lena Guidiccioni) | |
| 1. Introduction | 36 |
| 2. Uşaklı Höyük | 37 |
| 2.1 Methodology and activities | 37 |
| 2.1.1 Surface collecting | 37 |
| 2.1.2 Surface scraping on the slope of the high mound | 39 |
| 2.1.3 Test soundings on the mound | 40 |
| 2.2 The pottery assemblage | 41 |
| 2.2.1 The Pottery analysis | 42 |
| 2.2.1. ₁ Function | 43 |
| 2.2.1. ₂ Morphology | 43 |
| 2.2.1. ₃ Technology | 46 |
| 2.2.2 Fabrics | 48 |
| 2.2.3 Wares | 58 |
| 2.2.3. ₁ Brown Burnished Ware [Bb] | 59 |
| 2.2.3. ₂ Coarse Grained Ware [Cg] | 60 |
| 2.2.3. ₃ Drab Ware [D] | 61 |
| 2.2.3. ₄ Glazed Ware [Gl] | 64 |
| 2.2.3. ₅ Gold Wash Ware [Gw] | 65 |
| 2.2.3. ₆ Grey Ware [G] [Gp] [Gr] | 66 |
| 2.2.3. ₇ Kitchen Ware [K] | 67 |
| 2.2.3. ₈ Orange Slip Ware – [Os] | 68 |
| 2.2.3. ₉ Orange Fine Ware [O] | 69 |
| 2.2.3. ₁₀ Painted Wares | 70 |
| 2.2.3. ₁₁ Pink Slip Ware [Ps] | 81 |
| 2.2.3. ₁₂ Plain Ware [P] | 81 |
| 2.2.3. ₁₃ Pseudo-Brittle Ware [Br] | 82 |
| 2.2.3. ₁₄ Red Slip Ware [Rs] | 83 |
| 2.2.3. ₁₅ Reddish Brown Ware [Rb] | 91 |
| 2.2.3. ₁₆ Yellow Slip Ware [Ys] | 91 |
| 2.2.3. ₁₇ Handmade wares | 92 |
| 2.2.3. ₁₈ Other sites | 96 |
| 2.2.4 The typology | 98 |
| 2.2.4. ₁ Ceramic Classification Codes | 98 |
| 2.2.4. ₂ Morphological types | 99 |
| 2.2.4. ₃ Other morphological components | 160 |
| 2.2.5 Comparisons and tentative dating | 166 |
| 2.2.5. ₁ The earlier phases of occupation: from the faint traces of Late Chalcolithic to evidence of the Early Bronze Age/Middle Bronze Age transition | 166 |
| 2.2.5. ₂ The 2 nd millennium BC occupation, between the karum and Hittite periods | 169 |
| 2.2.5. ₃ The Iron Age occupation | 174 |
| 2.2.5. ₄ The Later Periods: from the second half of 1 st millennium BC to the modern occupation | 177 |
| 2.3 Small objects and other finds | 180 |
| 2.4 Scatters of sherds and other materials | 182 |
| 3. Other noteworthy identified sites: survey methods and findings | 184 |
| 3.1 Taşlık Höyük (site no. 3) | 185 |
| 3.2 Aşağı Karakaya Höyük (site no. 9) | 186 |
| 4. Concluding remarks | 188 |
| References | 190 |

| | |
|---|-----|
| General Charts of materials recovered on the site of Uşaklı Höyük | 195 |
| List of Diagrams | 199 |
| List of Schemes | 200 |
| List of Charts | 200 |
| Catalogue of Plates | 201 |
| Figures | 213 |
| | |
| BULLA WITH ANATOLIAN HIEROGLYPHS | 345 |
| <i>Massimo Poetto</i> | |
| References | 346 |
| Figures | 348 |
| | |
| EPIGRAPHIC FINDINGS | 349 |
| <i>Alfonso Archi, Carlo Corti, Franca Pecchioli Daddi, Giulia Torri</i> | |
| 1. Tablet UK09.E.2 | 350 |
| 2. Tablet UK12.E.3 | 351 |
| 3. Tablet UK12.E.4 | 352 |
| 4. Tablet UK12.E.5 | 352 |
| 5. Tablet UK14.E.3 | 352 |
| 6. Tablet UK15.E.62 | 353 |
| 7. KBo 52.280 | 353 |
| References | 356 |
| Figures and copies | 357 |
| | |
| EPIGRAPHIC EVIDENCE ABOUT ZIPPALANDA | 365 |
| <i>Giulia Torri</i> | |
| References | 366 |
| | |
| GENERAL BIBLIOGRAPHY ON UŞAKLI HÖYÜK | 369 |
| | |
| SURVEY EXPEDITION TEAM MEMBERS (2008-2012) | 373 |
| | |
| PLATES | 375 |
| | |
| CONTRIBUTORS | 421 |

THE ARCHAEOLOGICAL SURVEY: METHODS AND MATERIALS

Anacleto D'Agostino, Valentina Orsi
(with the collaboration of Guido della Lena Guidiccioni)¹

Abstract

The team of Florence University carried out an archaeological survey at Uşaklı Höyük, the largest site by area on the upper course of the Eğri Öz Dere, north of the Kerkenes Dağ, and its catchment area within a 5km range [1]. The aim of the research was to attempt to determine the date of occupation at the site and place it in a wider regional and chronological context, pinpointing the presence of further nearby sites and the development of settlement pattern over the course of time [2].

Combining extensive and intensive methods and varying sampling strategies, mounded sites, fields, grazing land, uplands and valley floors were explored over the course of five work seasons [2.1]. Along with collecting archaeological materials, focused scraping operations on the steep slope of the high mound were planned in order to obtain more information on the settlement sequence.

An intensive sampling strategy of all the artefacts relating to the main topographical or surveyed units had the initial aim of obtaining a detailed scatter of the different categories of finds. In each of the surveyed units we marked, mapped and picked up all of the artefacts found on the surface. This systematic collection yielded a sufficient amount of pottery to identify the ware and shape groups and, accordingly, to date the occupation of the site in terms of wide chronological periods [2.2]. Moreover, the dispersal of specific categories of materials provided an indication of areas where some of these periods may be better documented [2.3]. The surveying and collecting carried out in the field enabled us to sketch a rough history of settlement in the area, from the Late Chalcolithic to the Ottoman period [3]. According to our results, the site of Uşaklı shows an intensive phase of occupation dating to the 2nd millennium, and evidence for a significant settlement dating to the 1st millennium [4].

Özetçe

Arkeolojik arařtırmalar: yöntem ve buluntular. Floransa Üniversitesi'ne baėlı bir ekip tarafından gerekleřtirilen arkeolojik arařtırmalar, Eğriöz deresinin yukarı ıėırı boyunca ve Kerkenes Daėı'nın kuzeyinde yer alan ve bölgedeki en geniř yüzölçümüne sahip sit olma özelliėini taşıyan Uşaklı Höyük ile onu çevreleyen 5 km yarıaplı havzası üzerinde odaklanmıřtır [1].

Arařtırmanın hedefi, sit yakınında sonraki dönemlerde bařka yerleřmelerin de gözleendiėine ve yerleřim düzeninin zaman ierisindeki geliřimine dikkat ekerek, sit kapsamındaki yerleřmeyi tarih- lenmek ve daha geniř bir bölgesel ve kronolojik baėlam ierisinde deėerlenmektir [2].

Yaygın ve yoėun yöntemleri birleřtirmek ve farklı örnekleme stratejilerinden yararlanmak suretiyle tümsekli araziler, tarlalar, otlaklar, yaylalar ve alak vadiler beř alıřma sezonu boyunca dikkatle arařtırılmıřtır [2.1]. Arkeolojik buluntuların toplanmasına en olarak, yüksek höyüėün dik yamacı boyunca gerekleřtirilen odaklı yüzey kazıma operasyonları ile yerleřim sekansına dair daha fazla bilgi elde edilmesi planlanmıřtır.

¹ A. D'Agostino wrote §§ 1, 2.1, 2.2, 2.2.5, 2.3, 3; V. Orsi wrote §§ 2.2.1, 2.2.2, 2.2.3, 2.2.4 and developed the diagrams, bar charts and tables; they co-authored of §§ 2.4 and 4. G. Della Lena Guidiccioni entered the information in the catalogue of potsherds. Line drawings of ceramic sherds and objects (Figs 1-40) are by S. Martelli. Illustrations concerning the collecting units, scatterings of sherds and archaeological materials (Figs 41-91) were drawn by S. Bernardoni and R. Trojanis – Studio KULLA; the topographic plan used in these representations as drawn up by E. Mariotti, the geophysics plot by G. Carpentiero; A. D'Agostino and V. Orsi created the ceramics database used for the GIS.

Başlıca topografik veya araştırmaya tâbi ünitelerle ilişkilendirilen tüm artefaktları kapsayan yoğun bir örnekleme stratejisi ile, öncelikle farklı buluntu kategorilerinin ayrıntılı bir saçılımını elde edebilmek hedeflenmiştir. Araştırılan her bir ünite için yüzeyden elde edilen tüm artefaktlar işaretlenmiş, haritalandırılmış ve toplanmıştır. Bu sistematik buluntu toplama işlemi sayesinde teşhis edilerek şekillere göre gruplandırılmak için yeterli sayıda çanak çömlek ele geçirilmiş olup, buradan hareketle alandaki yerleşmenin daha geniş bir kronolojik dönem içerisinde tarihlendirilmesi mümkün olmuştur [2.2].

Buna ek olarak, belirli kategorilerdeki buluntuların dağılım düzeni, tarihi dönemlerden bazılarının daha iyi tespit edilmesinin mümkün olacağı alanların varlığına işaret etmektedir [2.3]. Yürütülen araştırma ve toplama çalışmaları sayesinde, alanın yerleşim tarihinin genel hatlarıyla Geç Kalkolitik Çağı ile Osmanlı Dönemi arasında uzandığı belirlenmiştir [3]. Elde edilen sonuçlar doğrultusunda, Uşaklı sitinin M.Ö II. milenyuma uzanan yoğun bir yerleşim sürecinden geçtiğini ve M.Ö I. milenyuma tarihlendirilebilen önemli bir yerleşim düzeninin varlığına dair kanıtlar sunduğunu söylemek mümkündür [4].

1. Introduction

The archaeological survey carried out by the team of Florence University concerned Uşaklı Höyük, the largest site by area on the upper course of the Eğri Öz Dere, north of the Kerkenes Dağ, together with its catchment area within a 5kms range. The aim of our research activity was to determine a date for the occupation at Uşaklı and place it in a wider regional and chronological context, pinpointing the presence of other nearby sites and the development of settlement pattern over the course of time.

Within the area selected for the prospection, some villages and sparse farms mark the current anthropic landscape together with agricultural fields; tracks and paved routes, a couple of small sized dams and reservoirs and little bridges across the streams complete the picture. The local rural economy is based mainly on intensive farming and breeding activities. The survey region comprises an undulating hilly area dotted by rocky spurs, crossed by streams and divided into small, often interconnected valleys. The soil quality is good, springs are common, trees grow along the banks of streams and building stones are readily and easily available. All of these natural elements occur together within a relatively short range from the site of Uşaklı.

In the last three years the physical landscape of the area has undergone continuous and rapid change, mainly due to the extensive engineering works involved in the laying of the Ankara-Sivas high-speed railroad (bridges and viaducts; opening of quarries; new routes and tracks for heavy vehicles between building sites and soil, stones and concrete aggregates quarries, crossing fields and flanking hills; relocation of inert debris) and the construction of new reservoirs for agricultural purposes (the main one being next to the village of Küçük Taşlık). These are profoundly altering the topography and consequently the traditional rural paths and communication network. The Yozgat-Sorgun highway² passes through the territory where the survey was carried out cutting it in two. The persistence of the communications network has been partially maintained over the centuries, and modern Turkish routes often retrace routes in use since ancient times. In this case the highway is located in a east-west oriented valley which, since at least Roman time if not earlier, has provided a main communications route between eastern and south-eastern regions of the Central Plateau, intersecting with an important south/north-western itinerary near Sorgun. The importance of this area within the regional systems of tracks undoubtedly held true also for ancient periods (see chapters by Mazzoni, Archi *et al.*, this volume) when the visibility of important landmarks from the valley floor of the Eğri Öz Dere, such as the Kerkenes Dağ (Summers 2014: 41-44) and also the mountains around Yozgat, provided firm visual reference points along the itinerary from Boğazköy towards Kayseri area.

Combining extensive and intensive methods and varying sampling strategies, mounded sites, fields, grazing, uplands and valley floors have been explored over the course of four work seasons but, on the whole, little evidence has been gleaned regarding the inter-sites variability and settlement pattern. This notwithstanding, the surveying and collection of materials in the field have enabled us to sketch a history of occupation of the valley from the Late Chalcolithic to the Ottoman period. Clearly it is a history told through glimpses of different sequences interspersed by collections from single period sites,

² The route E88-D200 is part of the international E-road network linking Ankara to Sivas and to Refahiye, in the Erzincan province.

and is very fragmentary from a chronological point of view. In fact, as concerns the periods attested by the collected materials some gaps remain but this is probably due to the nature of the surface survey research which has produced a partial and not entirely representative picture, as well as the particular character of the ceramic horizons of the north Central Anatolian Plateau. Here the development of the pottery production is shaped by a robust conservatism in morphology and techniques over the centuries, with the result that it is hard to identify fine-tuned repertoires for single, limited periods. Moreover, for the earlier periods, but not only, the marked regional character of the ceramic repertoire and the limited archaeological evidence often prevent any firm comparisons between materials from sites located in different though relatively close valleys. However, within these limits, and as a result of the Uşaklı Höyük Survey Project (hereinafter UHSP) we have been able to define the main phases of occupation and suggest an outline of the local settlement history.

2. Uşaklı Höyük

2.1 Methodology and activities

2.1.1 Surface collecting

After the first extensive territorial coverage we decided to concentrate our efforts on the main and largest site of the area with a focused survey of surface artefacts. Systematic collecting first concerned large portions of the site which had furnished more productive evidence during the geophysics prospection, namely the eastern sector of the flat terrace. Furthermore the flat area on the western edge of the terrace, where geomagnetic anomalies were weaker, was surveyed to test the quality of findings in a sector of the settlement which may have been different in terms of function or, at least, of archaeological deposit compared with the eastern portion. The aim of this approach was to have a representative sample of the different areas of the site that would enable us to delineate a framework of the settlement history.

The large extended terrace at the foot of the high mound and the slope of the high mound have been considered more productive for the collection of materials relating to structures identified under the topsoil by the geomagnetic and resistivity reconnaissance. The survey, in fact, focused on the north and north-eastern portions of the terrace and its E-SE low, slightly sloping base, where buried walls and structures have been identified. Furthermore, part of the southern and south-eastern slopes of the mound were explored in order to collect initial evidence concerning the chronological phases attested there.

An intensive sampling strategy of all the artefacts relating to the main topographical or surveyed units had the initial aim of producing detailed spreadsheets of the different categories of finds. As is generally known, the means of estimating the size of a multi-period site in each period of occupation is through systematic collection of all the artefacts aimed at establishing their spatial range. Through analysis of their scatter we are able to understand if there is a differentiation in the distribution pattern of different categories of finds and hence infer chronological and functional information regarding the superficial archaeological deposit. Obviously, there are various difficulties in putting the theory into practice. It is worth mentioning here that serious limits to a correct understanding of the initial location of artefacts, and the original distribution and composition of the archaeological record are posed by post-depositional activities such as human intervention and natural events. In particular, previous visits to the site and collections carried out in past years, intense agricultural activities and erosion could have resulted in quite marked modifications of the original location of the artefacts and their consistency³. In the case of Uşaklı all these factors have been documented and observed.

The area had already been partially surveyed by unsystematic explorations conducted by travellers and scholars and, in recent times, by American and British colleagues. The collections of surface sherds carried out by M. Balance and R. Gorny (Summers *et al.* 1995: 59) and then by G.D. and M.E.F. Summers, in the framework of the Kerkenes Dağ Survey Project (Summers *et al.* 1995: 53-59), provided us with the first organised pieces of information concerning the main phases of occupation. From these initial collections of data it was possible to establish that the major period of occupation was the 2nd

³ It is also true that, in the case of a multi period and extended site, erosion and ploughing affect the archaeological deposit but, at the same time, expose archaeological remains through the removal of vegetation and the disturbance of buried strata, periodically bringing new sherds to the surface.

millennium BC, followed by a later occupation (Iron Age, including Achaemenid up to the Roman/ Byzantine periods) mainly involving the high mound and portions of the lower terrace, the limits of which have not yet been determined.

Keeping this in mind, and conscious of possible bias in the displacement of artefacts, we decided to start the intensive collection, even though the position and concentration of sherds could only provide us with a map of areas in which the reliability of the deposit had to be verified by statistical analysis, separating possibly those elements that had come from buried strata of the deposit as a result of disturbance. We should also note that the intensive collection strategy applied could help, in part, to decrease the disadvantages caused by the limited visibility of surface finds (due to residual crops, ears, stems and dry straw as well as some herbaceous plants) over most of the terrace during the 2008 campaign. We opted for partially clear each square of vegetation with the use of rakes, being careful not to remove sherds or other artefacts: in so doing, the heap of vegetation removed was also examined for possible sherds that had been unintentionally dug up. This method was applied to the single collecting units and progressively adjusted to the different circumstances encountered over the course of the fieldwork. During the 2009 campaigns, the increased visibility resulting from an absence of residual crops and recent ploughing activity over a large portion of the lower terrace facilitated the collection of sherds and made our task both easier and quicker. Otherwise, the 2010 campaign was problematic due to the compact soil and dense vegetation covering the portion of the high mound slope surveyed which greatly reduced the visibility of archaeological artefacts.

The collection was carried out on separate portions of the flat surface constituting the top of the terrace and its gradual slope which descends to the valley floor and on the south-eastern slope of the high mound (Pl. 8). During a preliminary extensive inspection, these portions of the site showed a major concentration of sherds whereas the other sectors of the sites were characterised by a very low presence of materials. Only a handful of noteworthy sherds were gathered from other sectors of the site and located on the map with the total station.

The field method involved sampling survey units established on the basis of the morphological characteristics of single plots and following, on the flat areas, the general topographical grid. The method applied was based on dividing the surface into squares or irregular discrete units from which all the artefacts and diagnostic sherds scatters were collected during systematic field-walking. This intensive collecting concerned full coverage of 39 squares of 20x20m, 6 main survey sectors on the low slope (lots), leading off fanwise from the edge of the terrace, and 4 sectors on the high mound (Fig. 41). As regards the top of the terrace and the low northern slope, within the 20x20 m squares used for the geomagnetic investigations, we laid out smaller regular units, sixteen for each square, measuring 5x5 m. Differently, we decided to divide the six radial sectors (lots 1-4, -1, -2) on the E-SE slope respectively into five, four and three bands, irregularly shaped (like segments of a circumference, concentric with respect to the curve of the main mound and lower terrace) in order to fit the collecting grid to the morphology of the slope⁴, for a total of 27 collecting units. Similarly, the four elongated trapezoid sectors on the south-eastern slope of the high mound (lots 5-6, 7-8; trapezoid opening proceeding towards the foot of the mound) were divided respectively into seven and nine horizontal bands of different area⁵, for a total of 32 collecting units. In the case of the terrace slope we considered as limits of the single unit the main changes in level and agricultural field boundaries. These limits were, instead, completely arbitrary in the case of the south-eastern slope of the high mound because the sloping gradient is regular. The entire surveyed area where intensive collection was carried out totalled 3.2ha ca. equalling a little over 32% of the site coverage.

The fieldworker team in charge of gathering archaeological evidence consisted, on average, of seven operators during the 2008 campaign, five operators in the 2009 campaign and eight in the 2010 campaign; plus a member in charge of work at the total station. Shovels and rods were used to clean the soil of any residual vegetation not removed with the rakes. During 2008 campaign the surveyors took nine days to cover the entire area arranged for the collection; seven days during the 2009 campaign and again in 2010. Even so, as the low visibility fields could not be avoided, we attempted to compensate for this bias by reducing size of the area to be surveyed by one person. As regards the 2008 campaign, the average surface area intensively surveyed each day was c. 1511m² of which 1200m² on the slope; in 2009 the

⁴ The dimensions of these units (each lot is divided into different bands, coinciding with different collecting units) vary from 5x30m to 30x50m. The first band of units, near the edge of the terrace, is narrower; the dimensions increase as we move towards the valley floor. The particular form of sectors -1 and -2 is due to the curvature of the foot of the high mound.

⁵ Dimensions of units vary from 4x10m to 7x27.50m.

figure was 2216m² of which 388m² on the slope and in 2010, 336m² only on the slope of the high mound⁶. Over the course of the 2008 season each fieldwalker attained an average rate of coverage on the terrace of approximately 216m² per day, of 443m² in 2009 and 43m² in 2010. On the slope the average rate was respectively of 171m², 77,5m² and 43m². Generally the best visibility was registered on the slope of the lower terrace, regularly ploughed before our field season. The lowest level of visibility was found on the slope of the high mound which is not farmed and was covered by thick vegetation, mainly herbaceous plants⁷.

In each of surveyed units we marked, mapped and picked up all the artefacts from the surface⁸. Diagnostic artefacts, that is to say artefacts giving possible information regarding the chronology and function of the assemblage, all fragments and lithics, were systematically collected for each surveyed field unit as well as fragments of roof tiles and baked-bricks⁹. Also slags were collected and weighted. This sample includes various melted combustion residuals of building materials, like clay, bricks and stones (Pls. 34 and 35). The nature of the primary artefacts is often not clearly recognisable but a clay material origin is in the majority of cases the category most likely to be best documented. Among these, abundant remains of burnt bricks and wall elements, identified by the presence of reed impressions on the surface, have been recovered on the south-eastern terrace and on the southern terrace slope. A small number of burnt and melted stones have also been found. Along a middle band of the slope of the mound in particular and along the slope of the terrace, in correspondence with various animal lairs (fox dens), burnt red soils with ashes and fragmentary burned bricks have been observed which might be evidence of destruction by fire of those sectors of ancient settlement. The kinds of residuals seem to be very similar, soils and bricks having same inclusions, texture and macroscopic features, and the hypothesis of a single fire having involved large parts of the site is not, therefore, to be excluded.

2.1.2 Surface scraping on the slope of the high mound

Along with the collecting of archaeological materials, new systematic and integrated methods of surface survey were introduced in the course of the 2012 season, some of this are more invasive in nature¹⁰. A series of targeted activities were conducted on the high mound in an attempt to answer some of the questions posed by the initial research on the surface of the site. The issues concerned the chronological characterization of the occupation of high mound and the quality of architectural features which it should have been possible to identify under the topsoil according to the results of the geophysical prospection. Bearing this in mind, focused operations of scraping on the steep slope of the high mound were planned so to obtain further information regarding the settlement sequence. In particular, the scraping on the southern side of the high mound was aimed for gathering evidence for a general and preliminary date of the large building that appears so clearly in the geomagnetic survey. Here a large anomaly reveals the plan of a huge building at least 60 m long and 15 m wide, consisting of large halls or rooms with a regular plan (see the contribution of S. Mazzoni, this volume, § 4.2-3).

The presence of relatively dense vegetation, principally herbaceous plants, over most of the slope (Pl. 9: 1-3; Pl. 10: 4) had prevented good visibility of the soil during the previous surface survey campaigns. The slopes of Uşaklı were never used for agriculture or crops and had been never ploughed; consequently, the topsoil was very hard and showed very few exposed materials. Removing the topmost layer of soil by scraping was, therefore, the best method for obtaining results from the surface (Pl. 9 and 10). We decided to clear the soil of vegetation with the use of sickles and rakes and proceed with intense surface scraping with trowels and shovels in order to collect materials associated with

⁶ Total of surveyed units in 2008 is c. 1,3ha; in 2009 c. 1,5ha; in 2010 c. 2359m². Generally eight hours work per day was dedicated to the field activities.

⁷ These counts are offered here only as general indicators. The difference of coverage is also due to the fact that during the second part of the 2008 season more time was dedicated exclusively to the collection of sherds rather than other activities, such as the arrangement of the topographical grid and geomagnetic investigations that took up part of the team in the afternoons during the first days. During the 2009-2010 campaigns more time was dedicated to weighing, counting and recording pottery sherds.

⁸ The collection units were given individual names with the use of numbers and letters (20x20 m square labelled with letters and main units of the mound slope labelled as lots 5-8; those of the terrace slope as lots 1-4, -1 and -2; 5x5 m square and single small units of the slope labelled with numbers).

⁹ In the square J19, with the use of a total station we mapped the location of all the artefacts, diagnostic and not, so as assess the feasibility of a very intensive collecting approach. The difficulty of assigning the small body sherds to precise categories and wares led us to abandon this method as it was unproductive in terms of more detailed distribution maps.

¹⁰ The 2011 season was dedicated to completing the geomagnetic survey of the site.

the geomagnetic anomalies, located in the upper portion of the slope and possibly to expose the upper surface of sizeable archaeological features (namely traces of collapsed mud brick walls, ash pits, baked bricks). The method of collection involved the gridding of the slope into bands of various sizes or irregular discrete units from which all artefacts were picked up (Fig. 42).

The southern and south-eastern slope of the high mound were divided respectively into two elongated trapezoid sectors (Lot 9, Lot 11) and one sub-rectangular sector (Lot 12). Scraping activity was carried out where anomalies registered by geomagnetic prospection returned evidence of conspicuous buried features; single lots were then separated respectively into 9, 9¹¹ and 6 horizontal bands of irregular shape and extension. The area scraped totalled 1281.5 m².

The team, consisting of twenty operators (archaeologists and students) and two workers, proceeded together along a east-west line, progressively scraping the slope from top to bottom and collecting the surface materials in an integrated manner. The average amount of surface intensively surveyed each day was c. 107m² and each operator had an average rate of coverage of c. 5.3m². This low coverage is due to the lengthy and progressive activities involved: cutting herbaceous plants and their roots, pulling out grass, removing loose topsoil with buckets, scraping eroded soil until compacted hard soil first appear. As a result of removing a superficial layer, we exposed spots of mud bricks (bands 3-7 of lot 9), delimited patches of brown and red soils, and a few alignments (bands 4, 5, 8 of lot 11), probably remains of the upper surface of mud bricks walls, although with less detectable outer limits (Pl. 11: 1). The locations of these features were photographed, drawn and the plot overlapped with the anomalies clearly visible on the geomagnetic survey (Figs. 92 and 93). In some cases a direct connection between spots of burnt red bricks with some registered anomalies are identified; in others there is no relation between the two phenomena.

Also on the south-eastern slope of the mound, within a sector already surveyed in the previous years, a vertical band measuring 5x25m was cleaned and prepared for intense scraping (Pl. 10: 5-6). The area overlaps lots 5 and 6 of the 2010 survey where a few anomalies can be interpreted as a structure with 5 or 6 long rooms (approximately 30x22m). Remains of a little wall of rough, small stones in a single row were found on the western edge of the area.

The considerations concerning the main phases of occupation reached by intensive collecting of surface sherds were confirmed by the results of the scraping. The scraping did, however, partially modify the previously held interpretation arrived at following the intensive survey, providing a good repertoire both of handmade sherds dating to the transition between 3rd and 2nd millennium and of 2nd millennium BC types, previously underrepresented in this part of the site where the material dating to the 1st millennium onward seemed to be prevalent. The composition of the archaeological repertoire depends, obviously, on post-depositional activities, particularly natural events, in the case of the steep slopes of the höyük. Despite this, and the slipping of soil and materials due to surface erosion, the later deposits did not prevent us from seeing conspicuous 2nd millennium BC materials; on the contrary these materials are well documented and represent a significant portion of the artefacts collected from the south slope. A further relevant result of the scraping activity was the finding of three fragments of cuneiform tablets in possible relation to buildings located on the mound (see article by Archi *et al.*, this volume).

2.1.3 Test soundings on the mound

The 2012 field research program included two small focused 'superficial' dig operations: cleaning the granitic blocks on the surface of the north-west edge of the höyük; and testing the depth of the lower large anomaly at the foot of the southern slope of the main mound.

The first operation was carried out on the very top of the mound where different sections of a strong pseudo-circular anomaly are clearly visible and could belong to a fortification wall, assigned preliminarily to the later phase of occupation, the Roman/Byzantine period (Pl. 12). A small part of a wall, part of the north-west circuit system, was visible on the surface and consists of a parallelepiped granitic block and a few flat slabs adjoining it on the east. An area of about 5x1.50m (SW-NE oriented) and the stones whose upper side were visible on the surface were thoroughly cleaned with trowels, removing grass and superficial soil, in order to expose a small segment of the wall (Operation 1) and documented by drawing the visible architectural elements. The portion of wall exposed consists of two rows of ashlar separated by rough medium-sized stones, as a shallow sounding along its outer line indicates. The structure seems to have been built with dry stone walling. It is worth mentioning here that a slight

¹¹ The collecting focused only on the 7 lower bands, excluding the two above.

depression on the surface and a path are visible respectively in front of and next to this portion of the wall and diagonally along the slope, probably the remains of a path to the top (Pl. 2: picture at the bottom, on the left). At the moment we can only speculate about the existence of a path in correspondence to a possible gate, but we have no evidence about its possible date.

A second small 2x1.70m sounding (Operation 2; E-W oriented) was opened at the foot of the southern slope of the mound in order to identify elements pertaining to the large geomagnetic anomaly visible on the plot and/or possible components altering the signal within the soil matrix (Pl. 11: 2). Such a signal (3/4 m thick on the plot) probably refers to a structure running NW to SE. Excavations carried out in correspondence with an irregularly shaped stone only went down at a depth of about 1.20 m (+1118,90 a.s.l.) in a fairly homogeneous soil deposit with very few sherds worn by surface exposure, but no further elements were found. As an initial result of this small sounding, we can exclude the possibility that the structure producing the large anomaly lies close to the surface. The origin of this anomaly may be due to the accumulation of materials falling down from the top, but it could also have been caused by the presence of a revetment or a city wall at the base of the mound or an emerging natural spur of rock (see S. Mazzoni, this volume, § 4.2-3).

2.2 *The pottery assemblage*

Notwithstanding all the above-mentioned elements of disturbance, which result in the survey data being markedly biased, it has been possible to collect a good representative sample of ceramics. The site is characterised by relatively medium density and spatially extensive scatters. Systematic collection yielded a sufficient amount of pottery to enable us to identify the ware and shape groups and, accordingly, to date the occupation of the site in terms of broad chronological periods. Moreover, the dispersal of specific categories of materials indicated potential areas where some of these periods are better documented and conceivably archaeological structures could be in close proximity to the topsoil.

In the case of surface collections the relative date of the different assemblages relies on comparisons with dated finds whose chronology has been established in stratified deposits from nearby sites. This task is simplified when there are long exposed sequences and sites of short-lived occupation whose sequences partially overlap. This is not, however, the case of the region under examination. Dating surface pottery is a challenge, particularly in areas where there is no continuous stratified sequence nearby which has been excavated or, as is the case with the Central Anatolian Plateau, we do not yet know enough about the different assemblages, as U.-D. Schoop (2009: 146) noted, due to the marked homogeneity that characterised most of the pottery production over a long period of time. Thus, typological continuity and the slow development of types from the *karum* period onwards limit considerably our ability to date survey collections. Moreover we lack certain information about the true extent to which several wares and types were used. Comparisons from Uşaklı sherds and those recovered from stratified excavated contexts showing similar characteristics, such as profile, fabric and surface treatments, constitute the basic method used to date our material. This is possible only in cases of clear typological identification of the artefact and not, obviously, with the very small sherds or portions of walls, that make up most of our collection. Only in a limited number of cases did the presence of painted decorative motifs, or characteristic surface finishing or specific textures enable us to assign the specimen to a general category and propose a rough date for it. It is, however, worth mentioning that the chronology of the settlement has to be defined based on only a limited set of pottery types, given the marked conventionalism of Central Anatolia pottery production and the continuity of shapes and manufacturing techniques over the centuries. For many other types here are no parallels to be drawn with the repertoire excavated in other sites of the region.

Some fundamental points concerning the chronological assignment of certain pottery types have been determined, but it has not proved possible to distinguish different tempers for individual periods. In fact, fabrics continue to have a similar composition and similar inclusions and texture over the course of time. The possibility of assigning some common shapes in plain ware to a precise period is also still problematical. For all these reasons, the bulk of the pottery collection represented by body sherds is hard to date. A considerable proportion of the types collected can only be dated to very broad periods, or overlap two or more periods. In the figures and tables we have assembled a sample of sherds that are representative of different typologies found during the survey but, as noted above, the ceramic production is conservative and forms continue unchanged for many centuries. Below is an annotated reasoning about possible comparisons for main morphological types and wares. Not all the sherds in the figures will be commented upon. Only a limited series of types is evaluated as being reliable markers of specific chronological ranges. For these types we provide an interpretation of spreadsheets in a

specific section of this article (see § 2.3), where we also provide the rough scattering of the main and well-attested categories which cannot be defined more precisely from a chronological point of view.

Before we go any further, a last introductory remark is required. For different types only general and not systematic references are given. When parallels for one of our types are documented in one or two stratified sequences, this is considered sufficient to assign it to the corresponding general chronological framework; approximate and not complete series of parallels to all sites where a given type is attested are provided in the text. Let us examine the collections of sherds in turn.

2.2.1 *The Pottery analysis*

All of the potsherds identified on the surface were collected and processed. In the processing method, a distinction was made between diagnostic and generic sherds. Within the category of diagnostic sherds, samples were sorted out which would be more useful for morphological or stylistic investigations, mainly items comprehensive of rim, base, handle, spouts, decorated body-sherds or other plastic elements. The category of generics essentially includes undecorated body sherds, which are less informative. All of them were washed, counted and weighed, distinguished on the basis of ware and functional horizon. Diagnostic sherds, in addition, were filed and given a further, more specific classification. A selection was also drawn and photographed. The data were entered in a FileMaker Pro database and subsequently integrated on a GIS platform for the elaboration of the spreadsheets. At present, the collection is stored in the depot of the Uşaklı Höyük expedition's house in the village of Taşlık Köy (Yozgat/Sorgun), sorted into bags and boxes according to collecting units.

The analysis of the Uşaklı Höyük surface ceramic inventory had the main aims of investigating chronological distinctions, in order to trace a sequence of occupation at the site, evaluating the consistency of each phase and eventually locating areas in which individual phases may be more highly represented. Although numerous post-depositional events might have displaced the ceramic inventories from the spot where first they entered the archaeological deposit, uneven distributional patterns of identified chronological groups over the surveyed area might reflect the localization, concentration and/or accessibility of concealed archaeological remains of that phase. At the same time, marked differences in the occurrence of the different groups may be related to the importance or accessibility of the archaeological phase.

The identification of any potential generic functional differentiation of different areas of the site was also investigated.

The typology and the registration code were developed by the authors in the course of the archaeological expeditions undertaken between 2008 and 2013¹². The coding system was developed progressively in the field, and refined at the end of the survey project. Its basic principles satisfy the dual aim of recording surfaces ceramic finds and serving as a basis for the registration of the ceramic material that will be collected in future, planned excavations at the site¹³. In the analysis, priority was given to variables and attributes which were considered most informative in term of chronological differentiation, primarily those that could be connected with clearly datable specimens already known from the archaeological literature. Some difficulties arose, however, due to the nature of ancient central Anatolian pottery traditions, which show a high degree of continuity both in terms of technology (manufacturing and finishing techniques, selection of rough materials) and morphology¹⁴.

Three main aspects have been investigated: function, morphology and technology.

¹² The morphological classification has furthermore envisaged two revisions based on the drawings, a first undertaken during the archaeological field season 2013 and a second, definitive revision, in Florence, in winter 2013-2014. The preliminary systematization undertaken in the field season 2013 of the drawings of 2010 and 2012 ceramic materials envisaged the participation of students and other team members: Vincenzo Ippolito, Raffaele Ranieri, Margherita Dallai and Francesca Simi. Together with the authors of the present study, Guido Della Lena Guidiccioni contributed to the recording of the diagnostic sherds; Raffaele Ranieri (2009-2010), Martina Di Marcoberardino (2008), Vincenzo Ippolito (2010) and Guido della Lena Guidiccioni (2009-2012) to the preliminary registration (counts and weight) of pottery; Silvana Rubanu (2015) to the final revision of the counts of generic sherds. All of the team members contributed to the collecting, washing and storing of the pottery, and to entering the data. In line with the revision, the description of a smaller quantity of ceramic samples already published in previous preliminary reports has been modified and updated. Giacomo Casucci helped in the revision of cross references between inventory numbers.

¹³ Some groupings which do not immediately appear to be particularly significant for the present study (like statistically non-significant or markedly in depth differentiation of morphological sub-categories) have been kept in view of any future recovery of stratified materials.

¹⁴ Bearing this in mind, we decided not to limit our published sample only to the already acknowledged ceramic typologies, but to consider enlarged groups of types that include other variants with rather close similarities. We

2.2.1., *Function*

A generic functional classification has been adopted in order to identify the possibly macroscopic functional connotations of specific areas on the site. A very broad functional context of reference was indicated for each ceramic sherd according to macroscopic visual evidence of the piece. These refer to morphological, dimensional and technological attributes. The functional categories of reference isolated on this basis are a) Fine; b) Common; c) Storage; d) Kitchen.

The storage ware includes medium/long term storage vessels. Major principles for the sorting of ceramic sherds within storage ware relate to their size. The sherds sorted within this category in fact pertain to large vessels, with large rim-diameter and thick walls. The fabric, however varied, is consequently characterized by a relative abundance of inclusions.

The kitchen ware includes vessels presumably used in processing foods on fires and related to cooking activity. It can be recognised from technological aspects (temper, surface treatment), shape (good conducting shapes) or evidence of use (traces of fire). It includes sherds with walls varying in thickness from thin to medium, usually with low density fabrics.

With the definition of 'common ware', we intend to sum up all of the other ceramic sherds presumably pertaining to other functional categories that require further and more in-depth analysis¹⁵ (short term storage, processing without heat, medium and short distance transfer, tableware etc.)¹⁶. The range of functions of the common ware is extremely wide, as are the varieties in shapes and technological attributes. Overall, it comprises sherds with thin to medium-thick walls.

Fine ware is distinguished from all of these 'utilitarian classes' on the basis of its presumed connection with elite, ceremonial, non-utilitarian, display or special-purpose contexts. It is typically more finely made or elaborately decorated ('labor-intensive', Rice 1987: 210). It mainly includes sherds with thin to medium thickened walls, usually with highly depurated fabrics¹⁷.

The vast majority of the inventory pertains to the common ware ceramic horizon, while minor percentages are storage and kitchen wares. A limited number of fine ware examples were also found. Some of these correspond to specialised ceramic classes, like gold wash ware, orange ware and orange slip ware; others belong to larger ceramic classes, such as red slip ware, brown burnished ware, painted ware and yellow slip ware.

2.2.1., *Morphology*

As far as the morphology is concerned, we followed an intuitive classification process, developing a hybrid system which integrates qualitative and quantitative variables. The classification used here implies the combination of a use-oriented system (see Rice 1987: 215-217) with a solid geometry reference system (see Rice 1987: 217-222), the former mainly as a basis for the general labelling of large morphological categories and ceramic types, the latter to be used in sorting and separating variants. The solid geometry reference system adopted here conforms to the vessel contour classification proposed by A. O. Shepard (Shepard 1985: 225-229). In the classification of our profiles (see below), continuous profiles correspond to shapes where the sides extend continuously (inward or outward) without characteristic points other than end-points, thus without any point of vertical tangency, corner or inflection. Discontinuous profiles are those that present one or more characteristic points other than the end points. A sharp discontinuity corresponds to a corner point; a gentle discontinuity mainly corresponds to a vertical tangency or inflection point. Classification was carried out by visual inspection, that is, without the support of precise measurements.

The ceramic typology is essentially based on pot-sherds, related to more or less well-preserved sections of the vessel profiles¹⁸. Their classification into morphological categories is, therefore, greatly in-

hope a large repertory of ceramics might be of some use to future studies in order to isolate potential ceramic provinces once further ceramic types have been identified in stratigraphic contexts.

¹⁵ Such as laboratory analysis of trace elements, in-depth technological analysis and comparisons with clearly functionally characterized inventories.

¹⁶ For a classification of possible functions of vessels see, for example, Rice 1987: 208-210.

¹⁷ As far as the distribution charts and tables are concerned (Pls. 84-85), the fine ware has been counted and weighed together with the common ware. Its quantitative relevance was, in fact, too limited to be appreciated on the spreadsheets.

¹⁸ Unfortunately, they may provide incomplete or even debatable information about the general shape, function and even the technology used to produce the vessel they belonged to. However, most archaeological ceramic inven-

fluenced by the state of preservation of the samples. Popular terms with generic functional connotations such as 'plates', 'bowls', 'jars' etc., have been employed to indicate wide morphological categories and for the purposes of description. Despite the ample space this allows for subjectivity, it does help in defining what a particular ceramic type looks like (for comparison with the modern world) and how they 'may' have been used (Rice 1987: 211-212)¹⁹. General referential shapes are inferred on the basis of comparisons with suitable parent vessels from Central Anatolian sites. No specific attempt has been made to investigate the relation between shapes and specific functions, or inferences drawn as to how the ancient users perceived the vessels.

Each type is defined by an alphanumeric code. The number in the first position indicates the general morphological category to which the sherd might be related. The letter in the second position indicates a main morphological variant within the general group, while the subsequent numbers and small-case letters correspond to two grades of sub-variants.

A main distinction is between open shapes, where the minimum mouth diameter approximately corresponds to the maximum width of the vessel, and closed shapes, where the minimum mouth diameter is consistently less than the maximum width of the vessel²⁰. Plates, bowls and large, deep, open containers belong to the first category whilst, in the second we have pots, jars and large, deep, closed containers. Rim sherds that could be related to goblets and craters should be considered intermediate between open and closed shapes given the fact that although their general morphology may resemble a closed shape, the large mouth places them in relation to open forms. Functionally more specific types, such as lids, stands and strainers, stand alone, while other categories are represented by different variants of undetermined shapes. Variants and sub-variants are sorted on the base of the profile, attributes and components of the vessels.

As far as profiles are concerned (see scheme 1), a main distinction is between homogeneous/unbroken and discontinuous/broken profiles: the profile of a vessel is defined 'homogeneous' when it follows a single directrix (or reference line), whereas it is considered 'discontinuous' when the presence of more than one directrix divides the vessel body into different geometrical volumes. These may correspond to different structural sections of the vessel (e.g. body and neck of a jar, for which see scheme 2) or to two different portions of a same section (e.g. the upper and lower part of a carinated bowl or the upper and lower part of a biconical body in a jar). Location (in the upper, middle or lower part of a vessel or of a vessel's section) and quality (sharp, thus resulting in a carination, or gentle, thus resulting in a curve) of the discontinuity are also considered variables of interest. Both the sections above and below the discontinuity are subsequently arranged on the basis of their profile (straight, concave/flaring or convex/rounded/curved), orientation (very open; open/everted; almost vertical; vertical; closed/inturned)²¹, and extent (short, medium, long)²².

tories are primarily composed of sherds rather than of whole vessels, so a number of methods have been developed in order to determine shapes on the basis of fragmentary elements (see, for example, Hagstrum, Hildebrand 1990, with related bibliography, and Rice 1987: 222-224). Only sporadic complete profiles have been found on the surface and, since these are too few to justify a separate typology, these have been sorted into the general sherd typology. No complete vessel has yet been found.

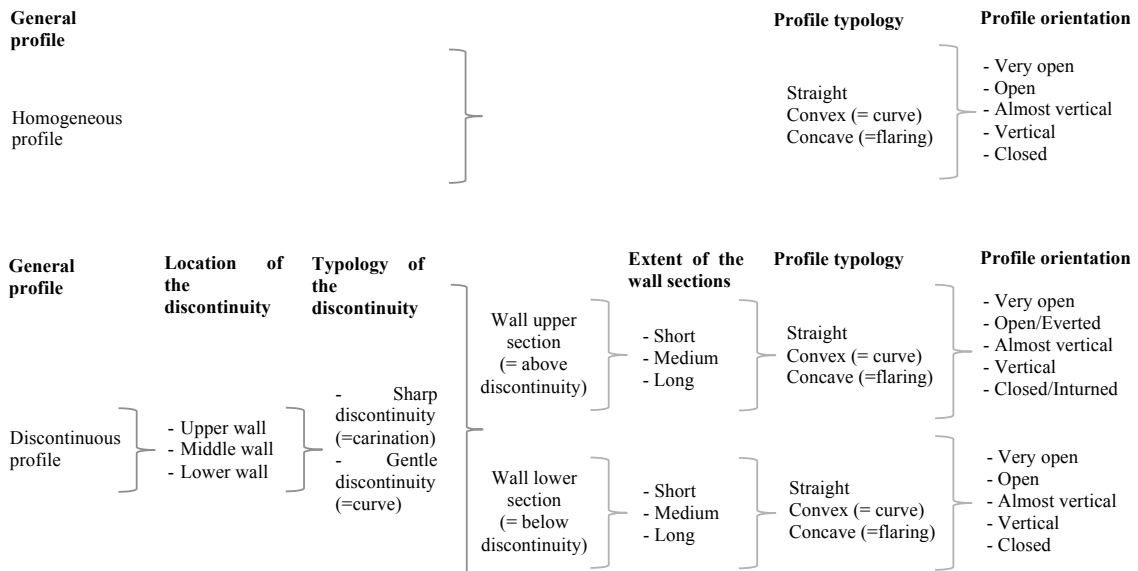
¹⁹ From a technical point of view, it would have been appropriate to name the sherd morphological series on the basis of their orientation (that is 'open', 'closed' etc. See, for example, Rova 2003) instead of referring to a general shape category not ascertained by a complete profile. Our choice, however, is dictated by our aim of offering a more immediate perception (through the use of familiar – if not precise – categories) of what the ceramic inventory looks like.

²⁰ Mouth diameters are one of most informative attributes as far as general function is concerned, since they reflect the accessibility of the vessels' contents. Usually, a more precise ratio is applied when distinguishing open from closed shapes. According to Hendrix (*et al.* 1996: 28-29), for example, an open shape is one, 'the minimum mouth diameter of which is 50% or more than the maximum diameter of the vessel. A closed vessel is one, the minimum opening of which is less than 50% of the vessel's maximum diameter'. As a survey ceramic inventory is mainly composed of fragmentary sherds, such measurements cannot be properly estimated and therefore, in our case, we opted for more general terms. Our distinction between open and closed shapes thus aims at providing a general functional interpretation rather than a quantitative classification in the hope that the published material will consequently be more readily usable.

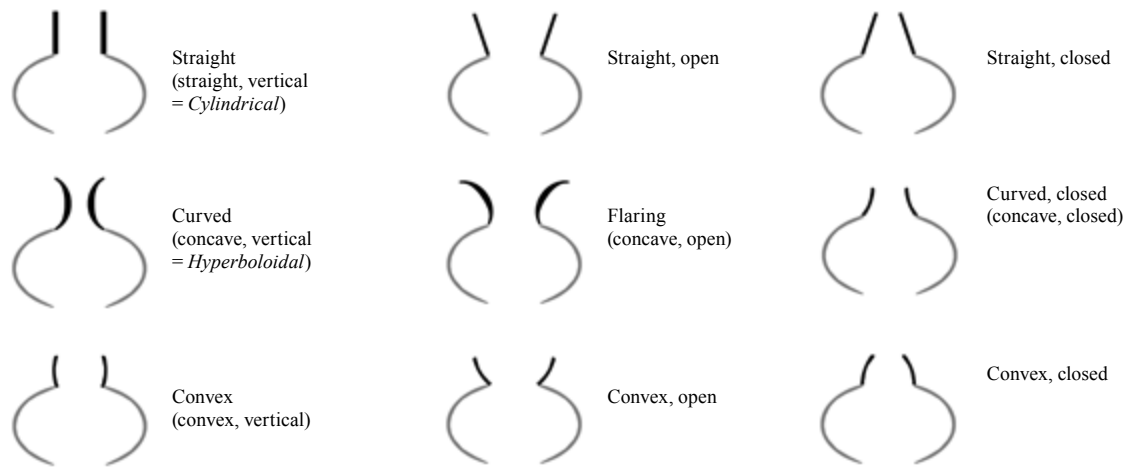
²¹ The wall of an open sherd, or one of its sections is said to be 'vertical' when the inclination of the sides is around 90°; it is said 'open' when the inclination of the sides is around 135° and 'very open' when the inclination of the sides is consistently greater than 135°, around 157.5°. 'Inclination' indicates the angle between the wall and the horizontal plane or base. The same principles are observed in the case of closed shapes in the description of the shoulders of the vessels, which may be 'almost vertical', with inclination around 90°, 'almost horizontal' or 'upraised', with inclination close to 0°, or 'intermediate' (simply described as 'closed'), with inclination around 45°.

²² According to these principles, bowls with continuous profile are distinguished between straight sided (= conical bowls), convex sided (= curved bowls) or concave sided (= flaring bowls), each variety orientation possibly being open (or 'very open'), or vertical (or 'almost vertical'). In bowls with discontinuous profile, the lower section

When the discontinuity is located in proximity of the vessel's mouth, however, problems may arise in the distinction between a discontinuity of the upper section of the vessel's wall and a discontinuity dividing the upper section of the vessel's body from the rim. Distinctions of this type imply an interpretative choice, and are most appropriate when the original function of the vessel is known. In our case, where only very general functional implications may be inferred (on the basis of visual analysis of morphological and technological aspects, since complete vessels are rare, the pieces are found out of context and there has, as yet, been no laboratory analysis), these are to be considered as relating more to 'terminology' rather than to the vessel's nature or to the way in which the vessel was perceived by ancient potters or users, aspects which are beyond the scope of this study.



Scheme 1: Typology of vessel profiles.



Scheme 2: Typology of neck profiles.

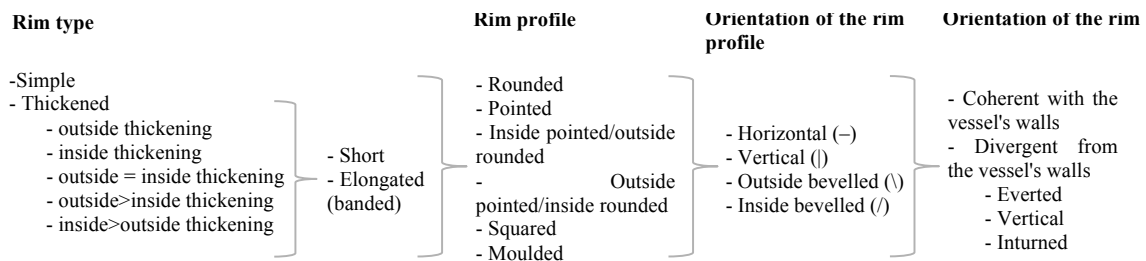
In identifying and sorting varieties within the general ceramic types, together with major profile variants, primary importance is given to rim typology. Being evidently affected by technology, envisaged function and style (Shepard 1985: 245-247), rim varieties are usually good indicators, in terms of visibility and recording, of general cultural aspects of chronological significance. The main principles

of the sides is categorised in the same fashion as homogeneous profile bowls (straight, curved or flaring; open or vertical), and in a similar way the upper section profile is recorded (straight, convex or concave; everted [= open], vertical or inturned).

of rim categorization (see scheme 3) are orientation, that is to say, the direction in relation to the contour of the vessel side, and thickness, as related to the thickness of the wall (see also Shepard 1985: 246).

As far as orientation is concerned, the rim may be coherent with the direction of the vessel side²³, or divergent. The divergence may be oriented outward, upward (vertically) or inward²⁴. On the basis of the presence or absence of an increased thickness as compared to that of the vessel's wall, the rim is defined as 'thickened' or 'simple' (that is 'non-thickened'). In thickened rims, an additional differentiation is made on the basis of the location of the thickening with respect to the body of the vessel: inside, outside and both inside and outside. In this last case, we further distinguish between predominantly outside or inside thickening and equally outside and inside thickening. The second analysed element is the rim profile (rounded, squared or bevelled, sharpened or pointed): in the case of complex rim morphologies the upper, lower, outer and inner section of the profile are described individually.

A major distinction is made between principle categories, those of 'plain' and of 'composite' rims. A rim is defined as 'plain' when shaped in continuity with the vessel's body (that is, same thickness and directrix profile between rim and vessel wall). A rim is, instead, defined as 'composite' when, in order to obtain a more articulated mouth, technical devices are employed such as thickening, grooves, or deviations from the directrix of the vessel wall (thickened rims, grooved rims, everted or inturned rims). This second category, which is obviously quite large in terms of variants, has however its own homogeneity with respect to the first²⁵. Technically different (or 'apparently' different) devices, that sometimes may even be quite difficult to single out, may convey a comparable appearance, thus suggesting the possibility of a comparable cultural choice underlying their shape²⁶. At the same time, comparable morphologies may relate to a shared functional sphere whilst the use of distinct technical devices may reflect a difference in other cultural spheres, possibly of chronological significance.



Scheme 3: Typology of rim profiles.

2.2.1.3 Technology

The technological classification is based on the methods of manufacture and finishing techniques, and it has been carried out in order to investigate the presence of culturally distinctive 'technologies', possibly to be evaluated in terms of chronology or of geographical characterization.

A main sampling has been made on the basis of wares. The concept of ware has been broadly employed in ceramic studies, frequently entailing different connotations (Shepard 1985: 318-319; Rice 1987: 286-287). In our study, the term 'ware' defines more or less broad ceramic classes isolated on the basis of diagnostic features. The system, therefore, does not constitute nor pretend to provide a uni-

²³ Corresponding to the 'direct' rim of A. O. Shepard (1985: 246).

²⁴ This mainly corresponds to the 'deviated' rim of A.O. Shepard (1985: 246). Among diversion categories of A.O. Shepard, however, a larger range of variables are numbered (inward, outward, up, horizontal and down), some of which in our categorization system fall within the 'profile orientation' classification.

²⁵ Often, for example, a slightly outside thickened rim has approximately the same appearance as a simple (= non-thickened) everted rim, or of a simple rim with a single outside groove. At the same time, bowls with inside thickened rims (see for instance no. 139) may be quite close to bowls with simple (= non-thickened) inturned rim (see for instance no. 147), thus suggesting possible behavioral relations.

²⁶ Due to the time/results ratio established for this specific study, an in-depth analysis of shaping techniques has not yet been carried out and it would, therefore, be appropriate to add the term 'apparently' when speaking of 'different technical devices' (that is, 'apparently different technical devices'). The detection of shaping techniques on the basis of a visual analysis is not always possible or precise, consequently, the readings proposed in this text, must be considered as suggestions.

form level of generalization (see at this regard Shepard 1985: 319). Major relations are connected with technological attributes, but the degree of specificity is extremely variable. Moreover, in order to facilitate the reader in the tasks of recognition and comparison, attention has been paid to well defined ceramic classes already known in archaeological literature which, when possible, have been integrated within the classification of the wares.

Manufacturing technology and surface treatment are principle attributes permitting distinctions to be made, followed by fabric, colour or function. A chief differentiation relates to types without additional surface treatment other than smoothing²⁷, which we sum up as simple wares, and types characterized by an additional treatment, such as coating, polishing, and painting²⁸.

Among simple wares, five main variants have been identified: plain ware, kitchen ware, drab ware, pseudo-brittle ware and coarse grained ware.

Among the other wares, thirteen main variants have been identified; handmade and wheel-made red slip wares, handmade and wheelmade painted wares, gold wash ware, orange fine ware, pink slip ware, brown burnished ware, yellow slip wares, grey wares, orange slip ware, reddish brown ware and glazed ware.

Descriptions of the technological attributes are based on visual and tactile examinations of the surfaces and of the fresh breaks, obtained by snipping off a small section of the sherd with a pair of pincers.

A first grouping of sherds into families was made on the basis of visual inspection of macroscopic characteristics: production technique (handmade or wheelmade); presence/absence of a slip or painting, colour of slip/painting and/or of uncoated surfaces, secondary surface treatment (trimming, smoothing, burnishing or polishing) and general evaluation of fabrics (fine, medium or coarse). A x5 hand-held magnifying glass was then used to detect wares and fabrics more carefully²⁹. Once a large sample of reference was established, the recording of individual sherds was carried out by naked-eye comparison with the reference samples³⁰.

When speaking about 'fabrics' we refer to a general classification of the final clay body of the fired sherds. Fabric is affected by the nature of the clayish matrix, temper (or added inclusions) and firing temperature and conditions. Visual analysis with the naked eye is not reliable in describing the clay matrix, nor in detecting a comprehensive range of tempering materials. Hence, observations in our report are to be considered as referring only to the relatively sizeable features of the paste. In addition, due to the intrinsic difficulties in distinguishing added elements from those naturally present in the original clay matrix (see Rice 1987: 406-413), we generally refer to 'inclusions' rather than to 'temper'³¹.

Munsell soil colour charts (2000 edition) have been employed as a reference for the registration of colours. The analysis was carried out under strong artificial light with a daylight bulb. The colours assumed by a pottery sherd depend chiefly on the size, amount and distribution of iron and organic material within the clay body, and on the time, temperature and atmosphere of the original firing (Rice 1987: 333).

²⁷ In the case of the kitchen ware, a burnish may be present, but this specific superficial treatment is mainly connected with the common functional destination. The burnishing or polishing of slipped wares not included in the group of simple wares, instead, may reflect more direct connections with cultural spheres other than function, mainly relating to styles.

²⁸ Painting is more frequently considered within other more clearly decorative attributes, such as incisions, excisions, applications or corrugations. In the analysis of our ceramic inventory, however, which is based on visual observations, some difficulties were encountered when making a distinction between red painting, basically rarer, and red coating, which is far more common.

²⁹ The sorting out of wares and fabrics was carried out at different stages in the course of the project. A preliminary grouping dates back to the first field season, in 2008. A main review was undertaken during the field season 2010, whereas a final check was made in May 2015.

³⁰ Such a strategy obviously depends on the specific amount of time we estimated could be devoted to registering the pottery sherds.

³¹ The term temper, even though widely employed in the archaeological literature with a general meaning, in fact implies a specific behavior, which involves the addition of specific elements to the natural clay matrix in order to modify the physical properties of the clay body. The term inclusions, instead, indicates components of the final clay body be these natural or voluntarily added (see Rice 1987: 407-411; Rye 1981: 31-32). In addition to inferences in the sphere of the intended use of the vessel, one of the principle factors in the choice of inclusions, of major interest in our study are implications in the sphere of style and technology. Differences of inclusions in a fabric, whether natural (that is, mainly connected with different clay sources), or added (that is, connected with behavior and technology) may indifferently determine groupings of cultural significance (in this regard see also Rice 1987: 409).

Organic material may result in grey, black or dark brown colours whilst iron contributes to red, yellow or brown colours if oxidized and grey, black or bluish when reduced.

A difference between surface and matrix colours may indicate a short lived change in firing conditions, while a difference between the inner and the outer margins in a sherd section may suggest that the mouth of the vessel was closed during firing, maybe because it leant, inverted on the kiln floor or was sealed by other vessels stacked above it. The presence of a dark core in the centre of a cross section, is frequently the result of organic materials present in the clayish matrix that have not been completely burnt during firing³². In these cases, we know that firing conditions, including temperature, duration and atmosphere, were not adequate for carbonaceous elements to be entirely removed (Rice 1987: 334). When observed on the ceramic inventory, this state has been generally summarised as 'low firing', 'incomplete firing' or 'inaccurate firing'³³. The firing conditions essential to obtain a complete oxidation of organic inclusions varies from ware to ware, depending on the original quantity of organic components of the clay, the nature of the other mineral inclusions and the thickness of the vessels walls. In coarse ware, carbonaceous particles start to be eliminated by fire even at relatively low temperatures. They burn more slowly in fine and dense fabrics because of the limited void space through which gases and particles can move (Rice 1987: 334-335). In the Uşaklı Höyük ceramic inventory a darkish core is very frequent in medium to thin walled vessels, suggesting recurrent technological behaviours.

Most of the wares identified have a consistently vitrified surface, so that porosity is considerably low. The same feature is obtained through burnishing, which is also quite frequent. The largest section of the ceramic inventory belongs to the family of simple ware, but the use of slip, especially red, as well as the use of paint, represents a significant part of the corpus. Incised decoration is quite rare, almost limited to simple horizontal or light, wavy lines. A few potsherds with stamp impressions have been recovered, predominantly pertaining to red slip ware body sherds (Pl. 20). Pot marks, instead, are sporadic.

2.2.2 *Fabrics*

Most diagnostic fabric types and variants have been catalogued with a serial number³⁴. For each fabric type and variant, a general tag is specified in italic print with its major attributes. References are given to the principles aspect of the matrix as visible to the unaided eye (sandy, gritty etc.), and to the nature of the most representative inclusions (mineral, vegetal or mineral and vegetal). Analysis using a x5 magnifying glass have been reported for the reference samples of the main fabric types³⁵. Fabric analysis is structured according to the following scheme:

- Texture (general evaluation of the paste grain)
 - Fine
 - Medium
 - Coarse
- Density (compactness/porosity)³⁶
 - Low [porous]
 - Medium
 - High

³² Organic (carbonaceous) matter is quite common in raw clays, and at the same time vegetal inclusions were frequently used as tempering material in ancient pottery productions. Heated in an oxidizing atmosphere, the carbon contained in the organic matter gradually decomposes, burning out from the interior to the surface of the piece in the form of CO₂ gas. Incomplete burning leads to grey colours.

³³ With this term, therefore, we intend to refer to a large range of circumstances including temperature not high enough; high enough temperature but not maintained as long as necessary, or insufficient oxygenation of the firing atmosphere.

³⁴ The classification represents a summary of major fabric types associated with the wares as observable to the unaided eye or with the help of a x5 magnifying glass. It is organized in order to provide a tool for an initial archeological registration of ceramic samples and designed for more in-depth archaeometrical analysis, checking and refinement.

³⁵ In the detailed description of the visible fabric components, the general term 'inclusions' has been used in reference to mainly small elements, while the term 'grit' has been employed to indicate larger elements. The term 'micaceous particles' refers to very small elements whose shape and colour can only be detected through a sparkling refraction of light. The definitions 'white' and 'whitish' have been employed to indicate respectively almost white elements from others whose colours include different nuances of white (like yellowish-white, pinkish-white etc.). References to the close-ups of freshly broken cross sections (not to scale) are provided for more significant samples.

³⁶ See Rice 1987: 231.

- Sorting (homogeneity in size of the inclusions)³⁷
 - Very poor
 - Poor
 - Fair
 - Good
 - Very good
- Inclusions
 - Quality:
 - Nature (Mineral, Vegetal)
 - Colour
 - Tentative qualification of rounding (Angular, Sub-angular, Rounded, Irregular, Flat)³⁸
 - Size
 - Frequency:
 - Abundant
 - Moderate
 - Sparse

Gritty fabrics, when characterized by large white or clear white angular grits and, especially, red angular grits, have been observed to be particularly frequent in the painted or yellow slip ware sherds most likely belonging to the 1st millennium ceramic horizons (Pl. 30). Sandy or small grit fabrics, instead, are more frequent in 2nd millennium red slip ware and drab ware sherds. Fine ware fabrics, depurated, with only minor visible inclusions, are chronologically transversal, while a higher variability is observed in coarse ware fabrics. Overall, the most of the ceramic inventory has mineral fabric, while large chaff inclusions are almost limited to the earliest and handmade production, referable to the 3rd and very early 2nd millennium BC.

Fabric Type 0: Medium grained, mineral. Grey and white inclusions, small, moderate frequency, micaceous particles, rounded voids of small size. The fabric has medium texture, medium density, fair sorting and moderate frequency of small inclusions. To the unaided eye, overall the prevailing inclusions appear white and grey. Grey inclusions are rounded, of small size, with moderate-high frequency. Among the white inclusions it is possible to isolate some whitish variants (mainly pinkish), with rounded shape, low sphericity, small size, with sporadic frequency. Other elements include white inclusions, clear, sub-angular shape, high sphericity, large size; white inclusions, rounded, very small size. The fabric is typical of red slip ware.

References (close-ups of cross sections Pl. 28, K08.2137, see below)

K08.728 (Fig. 26: 494, type ZA.2c, red slip ware)

K08.290 (Fig. 29: 557, type W, red slip ware). Analysis under magnifying glass – Texture: medium; density: medium; sorting: fair: moderate frequency of small inclusions. Visible inclusions and components include: voids, very small size, slightly elongated shape, moderate-high frequency³⁹; reddish-brown inclusions, rounded shape, very small size, moderate-high frequency; white inclusions, sub-angular shape, moderate/moderate-low frequency; darkish grey inclusions, rounded shape, very small size, moderate frequency; colorless inclusions (mainly taking grey colour with light), lamellar shape, sparse. To the unaided eye, the prevailing inclusions are the white, of rounded shape, small dimension, moderate frequency, and the colorless ones (or grey), glistening. Sands particles are visible, as well as voids of elongated shape, medium-small dimension, in moderate frequency.

K08.2137 (Pl. 28; Fig. 7: 157, type 2A.19a, red slip ware) is an example with slightly coarser texture and sorting approximately poor.

Fabric Type 1: Medium-fine grained, mineral. Prevailing inclusions of white colour (dull or clear, taking up a white colour under light), rounded shape, high sphericity, medium to medium-large size, moderate frequency. Examples are attested with slightly lower frequency of inclusions. Other components include micaceous particles and voids, elongated, very small, sporadic. Small grey grains, usually not visible to the unaided eye, may also be attested. It is typical of red slip ware.

³⁷ See Orton, Hughes 2013: Fig. A.6, with reference to Barraclough 1992.

³⁸ Qualification is considered 'tentative' when based on observation carried out with a x5 magnifying hand lens or on the close-ups of the cross sections. Terms are after Orton and Hughes 2013, with reference to Barraclough 1992.

³⁹ It is not clear whether these are related to small vegetal inclusions.

References (close-ups of cross sections Pl. 28, K08.1558; K08.2109)

K08.858 (Pl. 20: 1; Fig. 34: 632, red slip ware). Analysis under magnifying glass – Texture: medium-fine/fine; density: medium/medium-high; sorting: poor (fine grained particles matrix and relatively larger inclusions). Description of inclusions: whitish, rounded, low sphericity, small, moderate/abundant; white, rhomboidal, low sphericity, moderate; micaceous particles, moderate; voids, elongated, small, sporadic. Greyish core with orange margins.

K08.261 (Pl. 16: 1; Fig. 11: 272, type 2B.4b, red slip ware): prevailing inclusions are the whitish ones, mainly yellowish, with rounded shape, high sphericity, medium size, frequent. Low micaceous particles are visible. A few dark grey inclusions also seem to be present but when observed with a magnifying glass, these are not really clear: it is possible they are colorless particles taking the colour of the clay.

K08.1558: (Pl. 28; Fig. 11: 249, type 2B.2c, red slip ware): prevailing inclusions are white; sporadic larger white inclusions are present. Greyish grits are visible on the close-up of the cross sections but not to the unaided eye.

K08.2109 (Pl. 28; Fig.11: 271, type 2B.4b, red slip ware).

Fabric Type 2: *Medium/medium-fine sandy fabric, mineral. Prevailing white inclusions of small and very small size, rounded shape with high sphericity or flake shape.* Small micaceous particles are frequently visible, together with sporadic elongated voids, of small and very small size (maybe from vegetal inclusions). Other inclusions may be attested like small grey grains. Texture varies from fine to medium; density varies from high to medium; sorting ranges from fair to poor (fine or very fine grained matrix with larger inclusions). Overall it is quite close to the fabric type 1. It is attested in red slip ware.

References (close-ups of cross sections Pl. 29, K08.1747)

K08.1747 (Pl. 29, type ZA.1 red slip ware). Analysis under magnifying glass – Texture: medium; density: medium/medium-high; sorting: fair; inclusions: moderate-high frequency of small mineral inclusions. Description of inclusions: white, angular, very small, abundant; grey, angular, small and very small, moderate frequency; sparse micaceous particles. It is worth noting that sandy particles are clearer on the close-ups of the cross section. The white and grey particles visible under a magnifying glass are angular, low sphericity grits. In addition to these, whitish, reddish and clay coloured grits are also visible.

K08.806 (Type 2A.4c, red slip ware).

K08.1821 (Fig. 11: 261, type 2B.4a, red slip ware).

K09.314 (Fig. 11: 262, type 2B.4a, red slip ware).

K09.659 (Fig. 12: 298, type 2B.8, red slip ware).

Fabric Type 2.1: *Sandy fabric, mineral. Prevailing white inclusions from small to medium-small size.* The fabric has medium texture, low density and good sorting. It is a close variant of fabric type 2, from which it is distinguished by the slightly coarser fabric, with higher frequency of white inclusions of slightly larger size. It differs from fabric type 1 in the sandy fabric. It is attested in red slip ware.

References

K08.1549 (Fig. 26: 492, type ZA.1, red slip ware). Analysis under magnifying glass – Texture: medium; density: low; sorting: good. Description of inclusions: white, rounded, high sphericity, small and very small, abundant; white, sub-angular, low sphericity, small, moderate frequency; sand particles.

Fabric Type 3: *Small grit fabric, mineral. Prevailing white inclusions, rounded, high sphericity, medium/medium-large size, attested mainly in high frequency.* The fabric has medium texture, medium density and fair sorting. Close similarities are visible with fabric type 1, from which it is distinguished because the white inclusions are mainly dull, and not clear. It is attested in red slip ware.

References

K09.1277 (Pl. 17.3; Fig. 20: 459, type 6D, red slip ware). Analysis under magnifying glass – Texture: medium; density: medium; sorting: fair. Description of inclusions: prevailing white, sub-angular, high sphericity, medium/medium-large size, abundant; reddish brown grits, angular, medium size; linear voids, small, sparse (possible chaff).

Fabric Type 4: *Sandy fabric, mineral. Prevailing medium size white inclusions; grey-brownish inclusions. Possible sporadic vegetal inclusions.* The fabric has medium/medium-coarse texture; medium density and fair sorting. It is quite similar to fabric type 3, but distinguished by the presence of visible darkish grits. Moreover, texture in fabric type 4 seems to be slightly coarser than in fabric type 3. It is attested in red slip ware.

References (close-ups of cross sections Pl. 28, K08.1039)

K08.1039 (Pl. 28; Pl. 16: 3; Fig. 13: 318, type 2B.15b, red slip ware). Analysis under magnifying glass – Texture: medium/medium-coarse; density: medium; sorting: fair. Description of inclusions: prevailing white, rounded, both high and low sphericity, from medium to small size, moderate-high frequency; reddish-brown/greyish, angular, small size inclusions, moderate to low frequency; voids, elongated, small, sporadic.

Fabric Type 5: *Small grit fabric, mineral. White inclusions and darkish inclusions (darkish grey/darkish brown colour), mainly small size; sporadic medium-large size inclusions.* White, dark grey and dark brown inclusions, from small to medium-large size, abundant; possible mica, sparse; voids of very small dimensions, apparently of irregular shape. The fabric includes a small percentage of micaceous particles. It is attested in red slip ware.

References

K09.3 (Pl. 17: 4; Fig. 29: 541, type 20.A2, red slip ware). Analysis under magnifying glass – Texture: medium; density: medium/medium-high; sorting: fair. Description of inclusions: white inclusions, rhomboidal, small size, moderate frequency; brown grits, angular, small size, moderate frequency; grey, both angular and laminated shape, small size, moderate frequency; white, laminar shape, medium size, sparse; brown grits, angular, large size, sparse; white, rectangular, large size, sparse.

Fabric Type 5.1: *Small grit fabric, mineral. White inclusions and darkish inclusions (darkish grey/darkish brown colour), mainly of small size; sporadic medium-large size inclusions; sporadic reddish-brown inclusion of medium-large or large size.* Sporadic small, elongated voids, possibly deriving from vegetal inclusions. It is a close variant of fabric type 5, distinguished by the presence of sporadic reddish-brown inclusions of medium-large or large size and by sporadic elongated voids. It is attested in red slip ware.

References

K09.1274 (Pl. 17: 6; Fig. 12: 304, type 2B.11a, red slip ware).

Fabric Type 6: *Mineral fabric. Darkish inclusions prevailing (darkish grey/darkish brown colour); white inclusions, mainly small.* Similarities are evident with fabric type 5, from which it differs in overall prevalence of darkish inclusions over white ones, and in the absence of sporadic large inclusions. It is attested in red slip ware.

References (close-ups of cross sections Pl. 29, K08.1638)

K08.1638 (Pl. 29; Fig. 26: 500, type ZA.3b, red slip ware).

K08.929, (Fig. 20: 446, type 6C.6a, red slip ware): Analysis under magnifying glass – Texture: medium-fine; density: medium-high; sorting: fair; inclusions: dark-grey grits, rounded, high sphericity, small (and very small), abundant (larger samples of the same type are sparse); white, rounded, high sphericity, very small, moderate frequency (larger examples of the same type but with low sphericity – white, rounded, low sphericity, medium-small size – are sparse); voids, rounded, small, moderate frequency; yellowish inclusions, rounded, high sphericity, small, moderate-sparse frequency; micaceous particles, very small, sporadic.

K08.1907 (Pl. 20: 1; Fig. 34: 627, type W, red slip ware).

K09.08 (Pl. 20: 1; Fig. 34: 633, red slip ware)⁴⁰.

Fabric Type 6.1: *Mineral fabric. Darkish inclusions definitely predominant (darkish grey/darkish brown colour); low frequency of small, white inclusions. Sporadic elongated voids, medium-small size.* It is a variant of fabric type 6, distinguished by the clear predominance of darkish inclusions whereas the white ones are sparse. It is attested in red slip ware.

References

K08.2048 (Pl. 16: 1, type H7 red slip ware). Analysis under magnifying glass – Texture: medium/medium-fine; density: medium-high; sorting: fair. Description of inclusions: dark grey inclusions, small (and very small), abundant (larger examples of the same type are sparse); white, small, sparse; voids, elongated, small, sparse; micaceous particles, very small, sporadic.

⁴⁰ Both K08.1907 and K09.08 have a slightly denser and finer fabric compared to K08.929, with inclusions that are generally smaller, but overall they seem to pertain to the same group.

Fabric Type 7: *Small grits fabric, mineral. Clear white, white, and darkish grey inclusions.* Different variety of white inclusions, some of which glistening; darkish small grits. On the whole, darkish and whitish grains have approximately the same frequency. Mainly rough fabric. It is intermediate between fabric type 1, with which it shares the clear white inclusions, and fabric type 6, with which it shares the abundance of darkish grey grits. It is attested in red slip ware.

References

K08.1730 (Pl. 16: 1, type 2B.4a, red slip ware). Analysis under magnifying glass – Texture: medium/medium-coarse; density: low; sorting: good. Description of inclusions: grey/dark-grey, rounded, high sphericity, small, abundant; white, flake shape, small, moderate frequency; colorless, glistening flakes (probable mica), small, sparse; yellowish-pinkish, rounded, high sphericity, small, moderate frequency; voids, rounded, high sphericity, very small, abundant; voids, elongated, very small, moderate frequency (not clear whether connected with vegetal inclusions). Abundant darkish, reddish-brown, and white grits are visible to the unaided eye on external surfaces.

Fabric Type 8: *Sandy fabric, mineral. White and darkish grains, sporadic micaceous particles.* Similarities are visible with fabric type 5, from which it differs in a lesser variety of inclusions and absence of sparse, large inclusions, and with fabric type 6, from which it differs in the absence of a clear majority of darkish inclusions. It is attested in red slip ware.

References

K08.424 (Fig. 29: 546, type 20C.1, red slip ware). Analysis under magnifying glass – Texture: medium/medium-coarse; density: medium/medium-low; sorting: fair. Description of inclusions: white, rounded, high sphericity, small, moderate frequency; darkish, rounded and angular, high sphericity, small, moderate frequency; micaceous particles, small, moderate/moderate-low frequency; voids, irregular shape, small, moderate frequency.

Fabric Type 9: *Fine grained fabric, mineral. Low visible inclusions, mainly white and small; micaceous particles. Darkish grey very small inclusions may be attested.* It is attested in red slip ware.

References

K09.1 (Pl. 16: 1; Fig. 12: 301, type 2B.9, red slip ware).
 K08.1780 (type 2A.2, red slip ware).
 K08.1236 (Pl. 17: 1; Fig. 16: 346, type 3A.1, red slip ware).
 K08.993 (type 2A.1a, red slip ware).
 K10.67 (Pl. 16: 1, type H7, red slip ware).
 K10.66 (type 20B.1, red slip ware). Analysis under magnifying glass – Texture: fine; density: high; sorting: good. Description of inclusions: colorless, glistening inclusions, lamellar shape, small, sparse; micaceous particles, very small, sparse; white, rounded, very small, sporadic; voids, irregular, very small, sporadic.

Fabric Type 9.1: *Fine grained, mineral. Low visible inclusions: white, small; clear white, small; micaceous particles; darkish grey, very small; voids, elongated, very small, sporadic.* Slightly coarser variant of fabric type 9, characterized by higher frequency of visible inclusions. It is attested in red slip ware.

References

K09.1256 (Pl. 20: 1; Fig. 34: 631, red slip ware).
 K08.1673 (Pl. 16: 6, type B10, red slip ware).

Fabric Type 10: *Large grits fabric, mineral. High frequency of large size grits, angular shape, with low sphericity, whitish, white, clear white, light grey and grey.* Sporadic reddish-brown inclusions may be attested⁴¹. Smaller inclusions are whitish, white, clear white and darkish grey. Micaceous particles (both clear white or darkish) may be attested. Orange or red matrix. It seems to be very close to fabric type 7, but consistently distinguished by the average size of inclusions, which are larger in fabric type 10. It is attested in red slip ware and painted ware.

The group is not homogeneous: some minor variations are, in fact, registered among samples ascribable to fabric type 10. Overall they are characterized by an abundance of grits of large size (aver-

⁴¹ Since the reddish-brown inclusions are sporadic when encountered, it is not clear whether their presence should be considered as indicative of a significant variant or not.

age size, 1mm) and usually prevailing white grits, both dull and clear, rounded or, more frequently angular. Grey grits of the same typology may be numerous as well.

References

K09.623 (Fig. 11: 254, type 2B.3, red slip ware): represents a medium-medium/fine variant, with medium-fine freshly broken fracture. The colour of outer and inner matrix is 2.5YR 5/8, red; the colour of the nucleus is 7.5YR 5/6, strong brown. Analysis under magnifying glass – Texture: medium, medium fine; density: high; sorting: poor/very poor (fine grained matrix with larger inclusions, and inclusions of different size); inclusions: on the whole considerably abundant, both large and medium size, mineral prevalence. Description of inclusions: white, very large (up to 2 mm), rounded, low sphericity, sparse (probably limestone); white/clear-white rhombs, from small to medium large size, abundant (possible calcite); clear, flat inclusions, medium-large, sparse; grey, angular, low sphericity, large/very-large, sporadic (possible rock fragment); yellowish, rounded, high sphericity, medium size, sporadic; micaceous particles, small, moderate frequency; voids from vegetal inclusions, elongated with striations, large (up to 2 mm), sporadic; reddish-brown grits, middle/large size, angular, sparse.

K09.158 (Pl. 24: 7, Fig. 27: 525, type ZA.9, painted ware).

K08.1682 (Pl. 17: 1, type 2C.2, red slip ware): represents a slightly coarser variant, with irregular freshly broken section.

Fabric Type 10.1: *Large grits fabric, mineral. High frequency of large size, dull grits.* This seems to be a close variant of fabric type 10, sharing with the group the high variability of large, mineral inclusions, but distinguished by the higher frequency of whitish, dull inclusions compared to clear ones. Medium coarse texture, medium low density, poor sorting. The fabric of the reference pieces is grey. It is attested in red slip ware and in brown burnished ware.

References (close-ups of cross sections Pl. 29, K08.2030)

K08.2030 (Pl. 29; Fig. 26: 497, type ZA.2c, red slip ware).

K09.1231 (type 2B.5a, brown burnished ware).

Fabric Type 10.2: *Medium grit fabric, mineral. High frequency of medium and medium-large size grits of various quality, whitish, greyish and clear.* This is a close variant of fabric type 10, from which it differs in the reduced range of variety of the mineral inclusions. Reddish-brown grits are absent. Medium/medium-coarse texture, medium density, poor sorting. It is attested in painted ware.

References

K09.800 (Pl. 25: 6, painted ware).

K09.654 (Pl. 24: 5, painted ware).

Fabric Type 10.3: *Medium/Medium-fine grit fabric, mineral. Medium-high frequency of medium/medium-small size grits of various quality, whitish and greyish grits prevailing, sparse clear inclusions.* This is a close variant of fabric type 10.2, from which it is distinguished by the slightly smaller dimension of inclusions and the sparse presence of clear inclusions. Medium/medium-fine texture, medium-high density, poor sorting. It is attested in painted ware.

References

K10.39 (Pl. 24: 5, painted ware).

K10.40 (Pl. 24: 5, painted ware).

Fabric Type 10.4: *Medium/Medium-fine grit fabric, mineral. High frequency of medium/medium-small size grits of various quality. Greyish inclusions prevailing, whitish inclusions, sparse clear inclusions.* This is a close variant of fabric type 10.3, from which it is distinguished by the higher frequency of greyish inclusions over the whitish ones. Medium/medium-fine texture, medium-high density, poor sorting. It is attested in painted ware.

References

K10.1 (Pl. 24: 5, painted ware).

Fabric Type 10.5: *Grit fabric, mineral. Very high frequency of medium size grits, of prevailing clear white colour and flattened shape. Whitish and light grey inclusions are also attested.* It is a close variant of fabric type 10, from which it is distinguished by the different rate and frequency of grit inclusions. It has medium-coarse texture, low density and poor sorting. It is attested in painted ware and red slip ware.

References (close-ups of cross sections Pl. 30, K09.958)

K09.598 (Pl. 30; Pl. 24: 3; Fig. 33: 609, Type H15, painted, bichromic ware).

K08.1485 (type ZA.6b, light brown and red slip ware): it is distinguished for prevailing grits of grey colour.

Fabric Type 10.6: *Medium Grit fabric, mineral. High frequency of small and medium-large size grits of various qualities. White and whitish inclusions prevail; greyish, reddish brown inclusions and micaceous particles are sparsely found.* The fabric is characterized by high frequency of small size grits and moderate frequency of medium-large size grits. It has medium/medium-fine texture, with medium/medium-high density, and poor sorting. It is attested in painted ware.

References (clos-ups of cross sections Pl. 30, K09.677)

K09.677 (Pl. 30; Pl. 23: 4; Pl. 24: 3, painted ware).

Fabric Type 10.7: *Grit fabric, mineral. Very high frequency of medium and medium-small size grits. Prevailing inclusions are whitish grits of irregular shape, medium size, abundant. Other inclusions include: moderate frequency of light grey inclusions of angular shape and of reddish brown inclusions; sparse micaceous particles.* The fabric has medium texture, medium density and poor sorting. It is a close variant of fabric type 10.6. It is attested in coarse grained ware and brown burnished ware.

References (close-ups of cross sections Pl. 31, K09.213; Pl. 32, K09.230)

K09.213 (Pl. 31, type 2A.14a, coarse grained ware).

K09.230 (Pl. 32, Pl. 27: 1, Fig. 33: 606, type H13, coarse grained ware).

Fabric Type 10.8: *Grit fabric, mineral. High frequency of inclusions, from small to large size. Prevailing inclusions are medium size white grits of angular shape. Abundant clear, flattened inclusions of medium-large size; sparse whitish inclusions and grey grains of medium small size; sparse buff grains.* The fabric has medium, medium/medium-high density and very poor sorting. It is a close variant of fabric type 10.5. It is attested in coarse grained ware.

References (clos-ups of cross sections Pl. 31, K09.209; Pl. 32, K09.533, K09.172)

K09.209 (Pl. 31, type H6, coarse grained ware).

K09.533 (Pl. 32, type H6, coarse grained ware).

K09.172 (Pl. 32, Fig. 32: 595, type H6, coarse grained ware).

Fabric Type 10.9: *Grit fabric, mineral. Very high frequency of different mineral inclusions of medium and large size. White, angular and clear, flattened grits prevail.* Other visible inclusions include: whitish grits, large, sparse; moderate frequency of small size grey inclusions; sparse large angular grey grits. The fabric has medium-coarse/coarse texture, medium-low density, poor sorting. It is a close variant of fabric types 10.5 and 10.7. It is attested in coarse grained ware.

References (close-ups of cross sections Pl. 32, K09.163, K09.409)

K09.163 (Pl. 32, Pl. 27: 1, Fig. 32: 586, type H3, coarse grained ware).

K09.409 (Pl. 32, type H6, coarse grained ware).

Fabric Type 11: *Grits fabric, mineral. Abundant whitish and darkish grey mineral inclusions of different size. Intermediate between fabric type 10 and 5.* It differs from fabric type 2 in a higher variability and frequency of mineral inclusions; it differs from fabric types 3 and 4 in a greater variety of mineral inclusions, as well as the presence of elongated voids; it is quite close to fabric type 10, but differs in a lower frequency of clear and glistening inclusions in favor of whitish ones. It is quite close to fabric type 5, from which it seems to be distinguished by a higher frequency and possibly a slightly greater variety of grits inclusions. It is attested in red slip ware.

References

K08.1590 (Pl. 16: 1, type H7, red slip ware). Analysis under magnifying glass – Texture: medium; density: medium high; sorting: very poor (fine grained matrix with larger inclusions; inclusions of different size); inclusions: overall abundant, both medium and small size, mainly mineral, whitish. Description of inclusions: irregular lumps of whitish (mainly yellowish) colour, medium, small and very small size, overall abundant (possible limestone?); darkish grey inclusions, very small, moderate frequency; darkish grey large grits, rounded, low sphericity, sparse; micaceous particles, very small, moderate/low frequency; elongated voids, small, sparse.

Fabric Type 12: *Sandy fabric, mineral. Abundant white and whitish small inclusions, various sand particles, micaceous particles.* Similarities are visible with fabric types 2.1 and 4, from which it is distin-

guished by overall higher frequency and variety of sandy components; it is close to fabric type 11, but distinguished by the sandy appearance, higher frequency of small compared to medium size inclusions and a higher frequency of micaceous particles. It is attested in red slip ware and coarse grained ware.

References (close-ups of cross sections Pl. 29, K08.237)

K08.237 (Pl. 29; Fig. 26: 512, type ZA.7, Red-slip). Analysis under magnifying glass – Texture: medium/medium-coarse; density: medium-low; sorting: fair; inclusions: mainly mineral, overall abundant, prevailing whitish, of small size. Description of inclusions: white, very small, apparently rounded, high sphericity, abundant; whitish (yellowish), angular, high sphericity, small, abundant; reddish brown grits, rounded, low sphericity, medium/medium-small, sparse; darkish grey grits, small, moderate-sparse frequency; white, clear rhombs, medium size, sparse; micaceous particles, small, moderate frequency; elongated voids, small, sporadic.

Fabric Type 12.1: *Sandy/grit fabric, mineral. Abundant white and whitish medium size inclusions; various sand particles, mainly of greyish colour.* It is a coarser variant of fabric type 12, distinguished from this latter by the size of inclusions which, in 12.1 are larger, and by a slightly higher frequency of greyish grits. It is attested in red slip ware, typical of the large storage jars with buff and red slip.

References

K08.1026 (Pl. 17: 7; Fig. 24: 484, type 8B.2, red slip ware).

Fabric Type 13: *Small sandy fabric, mineral. Small white inclusions with sporadic, small chaff. Micaceous particles.* It is quite close to common red slip ware fabric like fabric types 1 and 2, but differs in the clearly visible, if sporadic, small chaff inclusions. It is attested in red slip ware.

References

K08.1921 (type 20C, red slip ware). Analysis under magnifying glass – Texture: medium/medium-fine; density: medium; sorting: good. Description of inclusions: white, very small, moderate frequency; whitish, small, sporadic; voids, elongated with striations down length (chaff), medium-small, sporadic; micaceous particles, very small, sparse.

Fabric Type 14: *Medium grained fabric, vegetal. Medium and large vegetal inclusions, abundant, and small white grains.* It is attested in handmade red slip ware.

References

K08.1275 (Pl. 16: 1; Fig. 6: 122, type 2A.16, red-slip handmade ware). Analysis under magnifying glass – Texture: medium-coarse; density: medium/medium-low; sorting: poor. Description of inclusions: vegetal inclusions (elongated voids with striations down length), from small to medium, large and very large size (up to 6.5 mm), abundant; white and whitish inclusions, rounded and angular, low sphericity, small and very small, moderate frequency.

Fabric Type 15: *Fine fabric, mineral. Very dense and fine fabric with moderate frequency of small darkish grey inclusions.* It is attested in yellow slip ware.

References

K08.797 (Fig. 30: 560, type W, yellow slip ware). The sherd has a very plastic matrix, with perfectly smooth fracture, slightly curved. Analysis under magnifying glass – Texture: very fine; density: very high; sorting: fair/good; inclusions: moderate frequency of inclusions of small size. Description of inclusions: darkish grey, mineral, angular, low sphericity, small, moderate frequency; white, very small, sporadic; micaceous particles, sporadic.

Fabric Type 16: *Fine fabric, plastic. Very dense and fine fabric, with smooth freshly broken section. To the unaided eye, it shows no clearly visible inclusions, apart from sporadic very small white particles or micaceous particles.* The same fabric is attested in gold wash ware, orange ware, red slip ware and brown burnished ware. It is registered also for the orange slip ware, but there no micaceous particles seem to be attested, and average density of the fabric is not exactly ‘high’, but ‘medium-high/high’.

References (close-ups of cross sections Pl. 29, K08.287; Pl. 31, K08.1086, K08.1606)

K09.1280 (Pl. 16; Fig. 32: 584, type H1, red slip ware). Analysis under magnifying glass – Texture: very fine; density: very high; sorting: very good; inclusions: sporadic visible inclusions of white colour, very small; micaceous particles: sporadic. The colour of the matrix is light brown (7.5YR 6/4).

K08.287 (Pl. 29; Pl. 17: 2, type 2A.6, orange slip ware).

K08.1606 (Pl 31, type 2B.1, gold wash ware).

K08.1086 (Pl. 31; Pl. 26: 1; Fig. 10: 223, type 2B.1, gold wash ware).

K09.1140 (Fig. 10: 225, type 2B.1, red slip ware).

K09.1145 (Fig. 10: 233, type 2B.1, red slip ware).

K08.375 (Pl. 17: 2, type 2B.1, red slip ware)

Fabric Type 16.1: *Fine fabric, plastic. Very dense and fine fabric, with smooth freshly broken section. To the unaided eye, it shows very small white inclusions, micaceous particles, and small voids with darkened borders.* It is a slightly coarser variant of fabric type 16, from which it is distinguished by the slightly higher percentages of visible inclusions. It is attested in painted ware of the so-called 'Galatian ware' horizon.

References (close-ups of cross sections Pl. 30, K09.589)

K09.589 (Pl. 30; Pl. 26: 4, painted 'Galatian' ware). Analysis under magnifying glass – Texture: fine; density: high; sorting: good. A low number of inclusions is visible: white, very small, sporadic; micaceous particles, sporadic; voids, both elongated or irregular, small, moderate frequency. Further small reddish lumps are visible on the close-ups of the cross section. Greyish core fracture.

Fabric Type 17: *Hard grit fabric, mineral. High frequency of different mineral inclusions, from small to large size. Reddish brown, greyish and white inclusions.* The peculiarity of this fabric is the presence of reddish/reddish brown inclusions. Both dusky red angular grits of medium size and reddish-orange rounded inclusions are attested. Medium fine-texture, high density, poor sorting. It presents some similarities with fabric type 10, with which it shares the dusky red grits. It is attested in yellow slip ware and brown burnished ware.

References (close-ups of cross sections Pl. 30, K09.297)

K09.297 (Pl. 30, yellow slip ware). Analysis under magnifying glass – Texture: medium-fine; density: high; sorting: poor; inclusions: mineral, abundant, various size and quality. Description of inclusions: reddish, angular, large, sparse; reddish, rounded, large, sparse; reddish, rounded, small, moderate-high frequency; white, very large, angular, flattened, sparse; white, angular, medium size, flattened, moderate frequency; clear, angular, flattened, medium size, moderate-low frequency; grey and darkish grey, angular, medium size, high frequency; micaceous particles, sporadic.

Fabric Type 17.1: *Grit fabric, mineral. Moderate-high frequency of different mineral inclusions, from small to medium size. Reddish brown medium size sporadic inclusions, white and grey inclusions from very small to medium size, micaceous particles.* The greyish inclusions are mainly flattened and glistening. As for fabric type 17, 17.1 presents typical reddish brown mineral inclusions, but in a lower frequency, whereas micaceous particles are substantial. Close similarities are visible with fabric type 10.6: they present the same range of inclusions, but in different ratios: the frequency of inclusions in 17.1 is lower, and the fabric is generally finer. The fabric has medium/medium-fine texture, medium density and poor sorting. It is attested in painted ware and brown burnished ware.

References (close-ups of cross sections Pl. 30, K09.789)

K09.789 (Pl. 30; Pl. 23: 1; Pl. 23: 3; Fig. 12: 275, type 2B.5a, painted monochrome ware).

Fabric Type 18: *Sandy fabric, mineral. High frequency of mineral inclusions, primarily of small size. Very high frequency of small and medium size light grey/clear white, sparkling particles; moderate-low frequency of large and flattened light grey/clear white sparkling particles.* Moderate frequency of small, white inclusions; sparse, angular, small grey inclusions; sparse large whitish grits. The fabric has medium texture, medium/medium-low density and very poor sorting. It is attested in coarse grained ware.

References (close-ups of cross sections Pl. 32, K09.1003)

K09.1003 (Pl. 32, type H3, coarse grained ware). Analysis under magnifying glass – Texture: medium; density: medium/medium-low; sorting: poor; inclusions: high frequency of mineral inclusions of small and medium size. Description of inclusions: clear (light grey/white) sparkling particles, angular, flattened, small and medium size, abundant; whitish and greyish inclusions, small, abundant; medium-large inclusions, clay coloured, sparse. A larger number of grits are visible on the close-ups of the cross section.

Fabric Type 19: *Medium-fine sandy fabric, mineral. Moderate/moderate-low frequency of small and very small grey inclusions, sparse white inclusions, sporadic micaceous particles.* The fabric has medium/medium-fine texture, medium/medium-high density; fair sorting and moderate/moderate-low frequency of visible inclusions of small size. It is typical of drab ware.

References (close-ups of cross sections Pl. 31, K08.1085)

K08.1085 (Pl. 31, type 2A.17b, drab ware). Analysis under magnifying glass – Texture: medium/medium-fine; density: medium/medium-high; sorting: fair; inclusions: moderate/moderate-low frequency of visible inclusions of small size. Description of inclusions: grey and darkish grey, small and very small, angular and rounded shape, moderate frequency; white, small and very small, rounded shape, moderate-low frequency; micaceous particles, sporadic⁴².

Fabric Type 19.1: *Medium sandy fabric, mineral. Moderate/moderate-high frequency of small and very small grey and whitish inclusions.* The fabric has medium texture; medium density; fair sorting and moderate frequency of small and very small visible inclusions. A more complex composition can be detected on the close-ups of the cross section, where the small and very small grey mineral inclusions observed with the unaided eye can be seen to be: small grits of rounded shape and low sphericity, darkish grey and grey, in moderate/moderate-high frequency; small grits of rounded shape and low sphericity, clay coloured, in high frequency. It is a close variant of fabric type 19, though slightly coarser and with larger grains. It is typical of the drab ware.

References (close-ups of cross sections Pl. 31, K08.1019, K08.271)

K08.1019 (Pl. 31, Pl. 18: 1, Fig. 3: 28, type 2A.1a, drab ware).

K08.271 (Pl. 31, type 2A.14a, drab ware).

Fabric Type 19.2: *Medium sandy fabric, mineral. Moderate/moderate-high frequency of medium size white and whitish inclusions.* The fabric has medium texture; medium density; fair-poor sorting and moderate/moderate-high frequency of medium size inclusions. Description of inclusions: whitish, small and medium size, angular shape, moderate/high frequency; white, small size, moderate frequency; clear white, medium-small size, sparse; grey and darkish grey, small, moderate-low frequency. It is a slightly coarser variant of the fabric type 19.1, from which it is distinguished by the higher frequency of white inclusions, more clearly visible to the unaided eye. Close similarities are visible with fabric type 1, typical of red slip ware, and with fabric type 20, which is typical of kitchen ware. Fabric type 19.2 is typical of drab ware.

References (close-ups of the cross sections Pl. 33, K08.362a)

K08.362a (Pl. 33, Pl. 18: 5, Fig. 5: 87, type 2A.10, drab ware).

Fabric Type 20: *Medium grit fabric, mineral. Moderate-high/high frequency of white, whitish and clear white inclusions of medium size.* Sparse micaceous particles. Sporadic large, white grits. The fabric has medium/medium-coarse texture; medium density; poor sorting and moderate-high frequency of medium size inclusions. It bears some similarities with some sub-variants of fabric type 10, like 10.8 and 10.9, typical of coarse grained ware (with which it shares the medium size white grits), and with fabric type 19.2, typical of drab ware (with which it shares the variety of inclusions). It is typical of kitchen ware.

References (close-ups of the cross sections Pl. 33, K08.2205)

K08.2205 (Pl. 33, Fig. 2: 18, type 1D, kitchen ware). Analysis under magnifying glass – Texture: medium/medium-coarse; density: medium; sorting: poor; moderate-high frequency of medium size inclusions. Description of inclusions: medium/medium-large whitish (yellowish) grits, angular, with low sphericity, moderate frequency; medium white inclusions, angular, with low sphericity, moderate frequency; clear white particles, small size, sparse; white, flake shape, small, moderate-high frequency; darkish grey inclusions, small, moderate frequency; micaceous particles, sparse.

Fabric Type 20.1: *Medium-coarse grit fabric, mineral. High frequency of whitish grits, whitish and greyish inclusions, clear white particles.* Sporadic large, white grits. The fabric has medium-coarse texture; low density; very poor sorting and high frequency of medium and small size visible inclusions. Inclusions visible on the close up of the cross section include: high frequency of whitish angular grits; moderate frequency of clay coloured angular grits; moderate frequency of white, grey, and darkish grey angular inclusions; sporadic reddish lump. It is a variant of fabric type 20, from which it is dis-

⁴² It is worth noting that a greater variety and frequency of mineral inclusions is visible in the close-ups of the cross section that cannot be detected with the unaided eye or under analysis with a x5 magnifying glass. Among these are sporadic yellowish inclusions of angular shape and small size; sparse reddish clusters of rounded shape, of medium and small size. Moreover, the frequency of the grey particles is considerably higher in the close-ups of the cross-section than in the result of hand lens analysis.

tinguished by higher frequency of inclusions, both medium and small size, and by the lower density of the paste. It is typical of kitchen ware.

References (close-ups of the cross section Pl. 33, K08.1816)

K08.1816 (Pl. 33, type 5A.8a, kitchen ware).

Fabric Type 20.2: *Medium grit fabric, mineral. High frequency of medium-small size white inclusions; moderate-high frequency of medium-small size darkish grey inclusions; abundant clear white particles.* Sporadic large, white grits. The fabric has medium/medium-coarse texture; medium-low density; fair-poor sorting and high frequency of medium-small size mineral inclusions. Inclusions visible on the close-up of the cross section include: moderate frequency of medium-small size white grits of angular shape, with low sphericity; high frequency of whitish and clay coloured inclusions of angular shape; moderate-high frequency of grey and darkish grey inclusions with angular shape; moderate frequency of small size white inclusions of angular shape. It is a close variant of fabric type 20.1, from which it is distinguished by the smaller average size of inclusions, a higher average frequency of darkish grey inclusions and a slightly denser texture. It is typical of kitchen ware.

References (close-ups of the cross section Pl. 33, K08.1)

K08.1 (Pl. 33, type 6B.3, kitchen ware).

Fabric Type 20.3: *Sandy fabric, mineral. Moderate frequency of small size white and grey inclusions. Sparse micaceous particles.* The fabric has medium/medium-fine texture; medium/medium-low density; fair sorting and moderate frequency of small size mineral inclusions. It is typical of the kitchen ware, but distinguished from the other kitchen ware fabrics 20, 20.1 and 20.2 by the sandy paste which renders this fabric similar to other plain and red slip ware fabrics.

References (close-ups of the cross section Pl. 33, K08.1995)

K08.1995 (Pl. 33, Fig. 20: 3, type 5A.9, kitchen ware).

2.2.3 Wares

In the analysis, the following wares have been distinguished (in alphabetic order):

- Brown Burnished Ware [Bb]
- Coarse Grained Ware [Cg]
- Drab Ware [D]
- Glazed Ware [Gl]
- Gold Wash Ware [Gw]
- Grey Ware:
 - Grey Ware [G]
 - Grey Ware, Painted [Gp]
 - Grey Ware, Rough [Gr]
- Kitchen Ware [K]
- Orange Slip Ware [Os]
- Orange Fine Ware [O]
- Painted Ware, Handmade:
 - Handmade, Painted Ware [Pt-Hm]
 - Handmade, Geometric Painted Ware ('Cappadocian') [C]
- Painted Wares, Wheelmade:
 - Wheelmade Painted Ware, Generic [Pt]
 - Wheelmade Painted Ware, Polychromic (= groups of painted wares n. 4, 10) [Pt-p]
- Pink Slip ware [Ps]
- Plain Ware:
 - Handmade Plain Ware [P-Hm]
 - Wheelmade Plain Ware [P]
- Pseudo Brittle Ware [Br]
- Red Slip Ware:
 - Handmade Red Slip Wares [Rs-Hm]
 - Wheelmade Red Slip Ware [Rs]
- Reddish Brown Ware [Rb]
- Yellow Slip Wares [Ys]

2.2.3., *Brown Burnished Ware [Bb]*

A relatively large number of sherds characterized by brown surface with polished or burnished finish has been assigned to the category of brown burnished ware.

The range of the surface colours includes different variants of light brown, mainly corresponding to the reddish yellow and the yellowish red of the Munsell soil colour chart (5YR 5/6 or 5/8, yellowish red; 5YR 6/6 and 7.5YR 6/6, reddish yellow or 6/4, light brown). The matrix may have a more reddish colour. With the exception of a few specimens, the difference between fabric and surface colours does not seem related to a slip, but to finishing techniques. In many cases, the presence of a self slip is more likely.

Finishing techniques usually consist of a rather accurate burnishing, generally horizontally directed. Samples with a slightly polished or carefully smoothed surface, however, have been occasionally recovered that appear to belong to the same category.

Great variability can be noted in the fabrics. Very fine samples are found with depurated fabric, fine texture, medium-high density, good sorting and only very scarce white, mineral inclusions of small size, mainly assigned to fabric type 16 (Pl. 29, K08.587, K08.264). Medium grit fabrics are quite common, characterized by large and small grey and red angular grits (Pl. 29, K08.665). These mainly relate to fabric types 17, 17.1, and 10.7, which, overall, show higher frequencies in first millennium ceramic types. Intermediate, sandy fabrics with a medium frequency of small mineral inclusions are also common (Pl. 29, K08.1851).

Both thin walled fine ware and common ware examples with roughly medium thickened walls are included in the inventory of brown burnished ware.

Although the range of morphological types is quite wide in terms of minor varieties, shapes are relatively standardised. Most of the sherds pertain to open vessels. Finer examples include small plates with convex sides (Fig. 2: 35), one of which is attested with a tripod base (Fig. 31: 582, Pl. 26: 2, K08.587); very thin walled, vertical, pointed rim bowls (Fig. 3: 51-52, type 2A.2), which correspond to a shape common also in other wares; bowls with thickened, outstretched rim (Fig. 10: 212, type 2A.29), and carinated bowls with everted upper sides (Fig. 20: 230-231, type 2B.1). Other shapes include simple bowls or plates with convex upper sides (Fig. 3: 63, type 2A.3; Fig. 12: 274, 280, type 2B.5), simple bowls with vertical upper sides and rounded rim (Fig. 6: 117-118, type 2A.16) and thick, carinated bowls with vertical upper sides (Fig. 10: 236-237, type 2B.2b). Particularly significant is the inventory of bowls with slightly thickened rim, usually with pointed profile (Fig. 5: 92, type 2A.11a; Fig. 8: 162, 167, 169, type 2A.19; 185, type 2A.22; 177, 180, 181, type 20; Fig. 9: 195-198, type 2A.23), or with carinated body (Fig. 13: 308-309, type 2B.12b). The inventory of closed vessels is limited to large-mouthed pots (Fig. 19: 395, type 5A.11), a few small jars (Fig. 19: 404, 414) and some high-necked jars (Fig. 20: 438, 440, 448). Ring bases also seem to be typical (Fig. 31: 572, 574).

The brown burnished ware would appear to be mainly related to the fine and common ware ceramic horizons.

Some variations, mostly encountered in fabrics, could suggest that the brown burnished ware might be related to different ceramic horizons. Some of the shapes of reference (see spec. shape type 2B.2b), are common to the red slip ware inventory, suggesting a possible relation, but major connections appear with yellow slip and wheelmade painted wares of the 1st millennium BC, with which they share different variants of bowl types (see above the references for bowls with thickened rim) and gritty fabrics.

References

Pl. 21: 7, K09.1101; Pl. 26: 2, K08.262, K08.587; Pl. 26: 4, K09.746; Pl. 27: 7, K09.1247; Pl. 29, K08.665, K08.2064, K08.1851, K08.587

Fig. 1: 5 (K12.1712, type 1A.3); Fig. 2: 35 (K12.1375, type 1J.1); Fig. 3: 41 (K12.1883, type 2A.1a), 45 (K10.71, type 2A.1b), 51-52, 57 (K12.2051, K10.4, K08.1851, type 2A.2), 63 (K12.1674, type 2A.3); Fig. 5: 92 (K12.197, type 2A.11a); Fig. 6: 117-118 (K12.195, K12.6, type 2A.16); Fig. 8: 162-167 (K12.123, K08.665, type 2A.19c), 169 (K12.553, type 2A.19d), 177 (K12.333, type 2A.20c), 180 (K12.423, type 2A.20d), 181 (K08.2064, type 2A.20e), 185 (K12.332, type 2A.22a); Fig. 9: 195-198 (K10.118, K09.1101, K09.966, K12.842, type 2A.23); Fig. 10: 212 (K08.262, type 2A.29a), 216 (K12.131, type 2A.29b), 236-237 (K12.7, K12.830, type 2B.2b); Fig. 12: 274 (K09.87, type 2B.5a), 280 (K12.49, type 2B.5b); Fig. 13: 308-309 (K12.15, K12.217, type 2B.12b), 311 (K12.435, type 2B.14); Fig. 18: 395 (K12.2061, type 5A.11); Fig. 19: 404 (K10.9, type 6A.4); Fig. 20: 438, 440 (K12.846, K12.66, type 6C.3), 448 (K12.573, type 6C.6b); Fig. 21: 464 (K08.1819, type 7A); Fig. 28: 535 (K08.855, type ZA.11), 537-538 (K12.236, K09.875, type ZC); Fig. 29: 556 (K09.1247, type W); Fig. 31: 572, 574 (K12.236, K09.875, type B5), 582 (K08.587, type B10+1J.1)

2.2.3., Coarse Grained Ware [Cg]

The label coarse grained ware refers to a group of sherds characterized by a rough surface, almost abrasive to the touch, with gritty and rather dense fabric, of reddish or greyish colour. It is fairly similar to the pseudo-brittle ware, from which it has been distinguished on the basis of more conspicuous wall thickness and fabric.

Although a thin, grey, watery wash seems to be attested in some samples, surfaces are mainly bare, with visible throwing lines.

Two main variants are attested, one with a reddish surface (2.5YR 5/6, red) and another with a mainly greyish surface, varying from grey, to light brownish grey, to yellowish (10YR 5/2, greyish brown; 6/2, light brownish grey; 5/1, grey). The fabric of the red surface variant may be either red (K09.213, Pl. 31) or, more frequently, sandwich, with a large greyish core and reddish margins. The matrix colour of the greyish surface variant is, instead, mainly buff, but fractures are frequently sandwich, with a large grey core and buff margins.

The fabrics are mainly gritty, with an abundance of both large and small mineral inclusions. A survey of the fabric sample is given in Pls 31-32 (see references list below). The texture is usually medium. The density varies from medium/medium-low (Pl. 32, K09.230, K09.162) to medium-high (Pl. 32, K09.172), with poor sorting. Visible inclusions are mainly abundant, including large white grits, large and smaller inclusions of various types. Among other inclusions there is a significant presence of light grey/clear white, sparkling particles (fabric type 18); white, angular, and clear flattened grits (fabric type 10.9); grey and buff medium-small grains (fabric type 10.8); reddish brown inclusions (fabric type 10.7).

We may associate the bowls K09.231 (Fig. 9: 209, type 2A.27b), K09.19 and K09.156 (Fig. 12: 286-287, type 2B.6, Pl. 26: 7) with the same group. They present the same rough surface appearance and approximately the same fabric as the other coarse grained ware sherds but differ in the presence of a buff slip, partially preserved. K12.440 (Fig. 20: 451) does not perfectly match the rest of the group, although the surface treatment is quite similar. The surface has a deep yellowish colour that recalls some of the coarse grained ware greyish samples, which frequently present various yellowish shades on the surface and have a buff fabric.

The range of shapes is not very large. Handles, usually with medium-large and flattened section, constitute a large percentage of sherds pertaining to the coarse grained ware, frequently with central concavity (see nos. 585, 589, 595, 596, 606; handles type H3, H5b, H6, H13). Bowls with anti-splash orifice and outer thickened rim or band under the rim (shape type 2A.27b and 2B.6) are typical. Sporadic open shapes include large bowls with a deep groove under the rim (shape type 2B.14), conical bowls (shape type 2A.11b) and curved bowls with thickened and grooved rim (shape type 2A.28). Closed shapes include large mouthed jars (see no. 429, shape type 6B.7), trefoil jars (no. 455, shape type 6C.9) and short necked jars (no. 416, shape type 6b.4).

Similarities are evident with some plain, drab and kitchen ware in terms of the coarse surface appearance, but this type is set apart by its specific range of colours and fabrics.

On the whole, the group hints at a rather standardized and fast manufacture, suggesting a relatively large scale of production. Despite some similarities with the kitchen ware production, to which some of the samples may be attributed, the general horizon of reference is that of the common ware.

Close similarities are visible with the ceramic production of the Survey Site 9. With the exception of a few sherds, however, no direct correspondence has been observed. The closest examples are the small jar K09.599, which has the same fabric type as the average Site 9 production, and K09.1185, a rim fragment of a jar with implanted, large handle. This last example is considerably thicker than the average ceramic production of Site 9, and the fabric is also slightly different, being sandier and with a lower frequency of grits, but the decoration consisting of incised dots is distinctive of the Site 9 inventory, making it likely that they are from the same chronological horizon.

K12.1514 (Pl. 17: 5, Fig. 34: 636), in plain ware, is another piece whose fabric and surface, together with the typical light impressed and excised decorative pattern, recall the main pottery production from Survey Site 9.

The fabric of K09.947 (Pl. 32, Pl. 27: 3, Fig. 32: 594) is slightly different from the rest of the coarse grained ware, but both shape and surface treatment seem coherent with the same ceramic horizon, as again also for K09.329 (Pl. 32, Pl. 27: 3).

As far as the other coarse grained ware samples are concerned, an interpretation within a chronological horizon close to that of the Survey Site 9 seems probable.

References:

Pl. 22: 4, K09.878; Pl. 26: 5, K09.949, K09.982, K09.802; Pl. 26: 7, K09.19, K09.1056; Pl. 27: 1, K09.163, K09.230, K09.948, K09.155, K09.515, K09.1172, K09.287, K09.945, K08.2181, K09.213; Pl. 27: 3, K09.947, K09.329; Pl. 27: 7, K09.1185, Pl. 31, K09.209, K09.213; Pl. 32, K09.329, K09.533, K09.230, K09.172, K09.163, K09.947, K09.409, K09.1003

Fig. 5: 94 (K09.949, type 2A.11b); Fig. 9: 209 (K09.231, type 2A.27b), 211 (K09.802, type 2A.28); Fig. 12: 286 (K09.19, type 2B.6), 287 (K09.1056, type 2B.6); Fig. 13: 312 (K09.287, type 2B.14); Fig. 19: 416 (K09.878, type 6B.4); Fig. 20: 429 (K09.1172, type 6B.7), 451 (K12.440, type 6C.7), 455 (K09.515, type 6C.9); Fig. 26: 509 (K09.982, type ZA.6a); Fig. 32: 586 (K09.163, type H3), 589 (K09.1185, type H3), 594 (K09.947, type H5.b), 595 (K09.172, type H5b), 596 (K09.948, type H6); Fig. 33: 606 (K09.230, type H13).

2.2.3.3, *Drab Ware [D]*

A sizeable number of samples in the larger family of simple wares is most likely to be interpreted within the so-called drab ware horizon.

The definition of drab ware is largely used in archaeological literature in reference to the predominant fabric type in the ceramic assemblages of the Hittite period in the northern part of Central Anatolia. It is typical of any 'Hittite pottery inventory' found from the beginning of the *karum* period until the end of the Late Bronze Age period. It is wheelmade, unslipped, with a roughly smoothed surface (Schoop 2011b: 242).

As far as the UHSP ceramic inventory is concerned, together with morphological comparison with stratified and classified materials from other sites, the main distinguishing factors for the attribution to the drab ware class are some particularities of the surface to which reference is most frequently made in archaeological literature. This, in fact, is characterized by evident rilling, resulting from wheel-throwing, and by trimming marks, left by the use of a sharp tool over the surface in order to remove excess clay and imperfections from a vessel, usually (see Rice 1987: 137) when it is leather-hard⁴³. Trimming traces include simple scratched lines or broader strokes, obliquely or, more rarely, vertically oriented (Pl. 31, K08.271). Despite trimming, small lumps of clay and other irregularities are still visible on the surface of some samples (see K08.1096, Pl. 18: 2, Pl. 31).

The colour of the paste and surface is most frequently brown (7.5YR 5/2 or 5/3, brown); less frequent are buff, brownish-orange (5YR 5/4, reddish brown) or light brown examples (7.5YR 6/3 or 6/4, light brown).

Typical Hittite drab ware, as described by W. D. Schoop, is characterized by a 'completely oxidized biscuit and buff colouring'. Dark cores and grey surfaces, instead, on the basis of the ceramic inventory of the Upper City of Boğazköy (Müller-Karpe 1988: 161-162; Parzinger, Sanz 1992: 68-70) as well as of Norşuntepe (Korbel 1985: 126-128), are considered the signs of a technical deterioration accompanying the later stages of the sequence (Schoop 2011b: 242)⁴⁴. The majority of our drab ware inventory do have a darkish core, indicating careless or poor firing, and brown surfaces that seem to suggest closer similarities with the later rather than the earlier production. The numerous similarities (see § 2.2.5.2) which the pottery inventory of Uşaklı displays with the earlier stages of the Hittite sequence does not, however, seem to support a date for our drab ware solely within the later stages of the sequence. Although such a scenario cannot be excluded, at present it seems more likely that this difference is to be explained not in terms of chronology but of a slight variation in the technological and productive sphere, denoting less careful production methods. This, moreover, finds a parallel in the red slip ware repertoire, where the frequency of dark cores is similarly very high.

The fabrics are overall medium/medium-fine, sandy, with mineral inclusions. They have medium/medium-fine texture, with medium density and fair or fair to good sorting. Visible inclusions, usually small or very small, are of medium to low frequency. Most of the inclusions coincide with white and grey particles, while micaceous particles are sporadically attested. In most cases, darkish grey particles of angular shape prevail.

⁴³ On the basis of this choice, the frequency of the drab ware samples among the ceramic inventory of Uşaklı Höyük may have been slightly underestimated: very close samples whose technological properties do not satisfy the established parameters have, in fact, been sorted into the more general group of plain ware. To compensate for this, however, morphological variants without exact comparisons with other stratified samples but with matching fabric and surface appearance have been assigned to the group of drab ware.

⁴⁴ In the Upper City of Boğazköy this late and coarser production has, in fact, been separated from the classical drab ware group as 'Töpferofenware' or 'pottery kiln ware' (Müller-Karpe 1988: 161-162; Parzinger, Sanz 1992: 68-70).

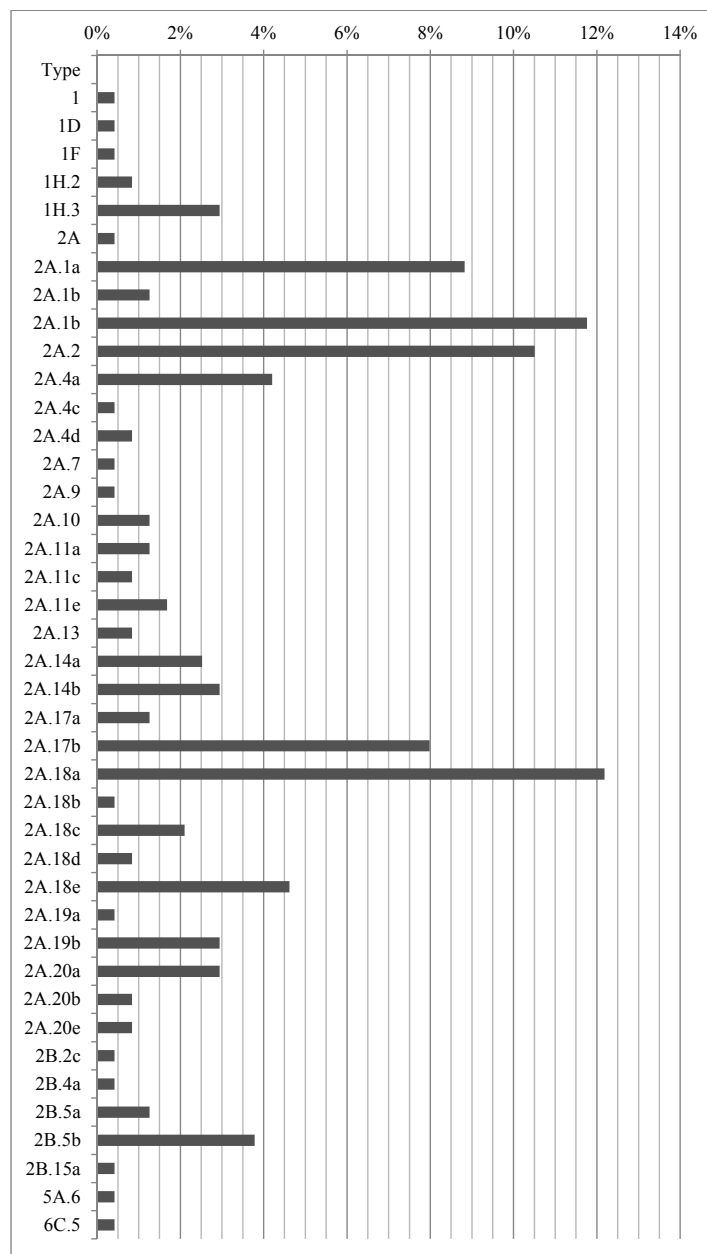


Diagram 1a: The range of morphological types in drab ware⁴⁵ – Code layout.

Typical fabrics are type 19 (Pl. 31, K08.1085) and the coarser variants types 19.1 (Pl. 31, K08.1019, K08.271) and 19.2 (Pl. 33, K08.362a). There are, however, similarities with fabric types more frequently found in other wares. Affinities are evident between finer drab ware fabrics and some of the red slip ware fabrics (see fabric type 1, Pl. 28, K08.1558; K08.2109, or fabric type 8), from which they are distinguished mainly by a lesser frequency and variety of inclusions. Coarser drab ware fabrics, instead, are closer to kitchen ware fabrics (see fabric type 20, Pl. 33, K08.2205), which usually present a higher frequency of grits inclusions.

Overall, the range of shapes attested in drab ware mainly relate to small or medium-large size bowls with light anti-splash morphological elements such as slightly diverted upper section of the sides or inside thickening of the rim. In terms of UHSP registration code, the set of morphological variants is quite large, comprising up to forty-one types (see Diagrams 1 for the complete list). In many cases, how-

⁴⁵ Percentages are calculated on the total of 238 drab ware diagnostic sherds with identified morphology. For the description of the codes listed in the diagrams, see § 2.2.4.₂ - Morphological types.

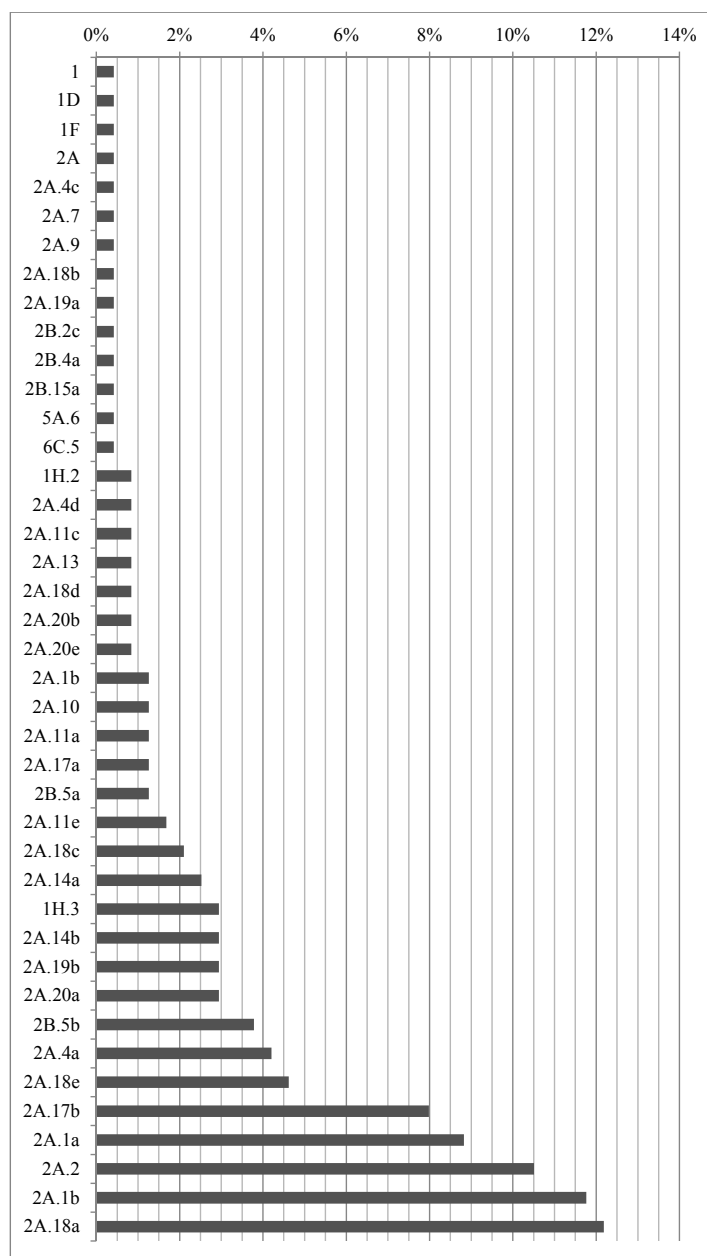


Diagram 1b: The range of morphological types in drab ware – *Bottom-up layout*.

ever, is it a matter of sparse samples or general types⁴⁶ which, taken alone, are not particularly significant in terms of frequency. More indicative is an intermediate group of types whose frequency ranges from 2% to 5% of the total of diagnostic drab ware sherds. On the Diagram 1b they range from shape type 2A.18c up to 2A.18e. They include plates or shallow bowls with inside thickened rim (type 1H.2 and 3); simple bowls with the rim thickened inside and outside bevelled profile (type 2A.14); simple bowls with curved sides and outside pointed rim (type 2A.19a and 19b) and simple bowls with inside thickened rim (type 2A.20a and 2A.4a).

In addition, a series of carinated bowls are attested, such as upper closed, convex sides bowls (2B.5), or sporadically, upper side or short upper side closed bowls (2B.4a, 2B.2c). Large carinated bowls with vertical upper sides (type 2B.15a) are sporadically attested: close variants with sharp and marked car-

⁴⁶ See Diagram 1b: 14 types, from 1 to 6C.5, relate to sporadic attestations of single sherds (0.4% of the sum of the diagnostic drab ware sherds), while a further 13 types, from 1H.2 to 2A.11e, relate to sparse attestations of two (0.8%), three (1.3%) and four (1.7%) sherds.

ination (see types 2B.16-18) have been sorted into the more general category of plain ware, but fabrics and surfaces are frequently very close to that drab ware⁴⁷.

Bowls of type 2A.18, with simple profile and convex upper sides are quite frequent, with the large variant (type 2A.18a) occurring most often, followed by the medium and small size variant (2A.18c and 2A.18e) whilst examples with squared rim (2A.18b) and small bowls with inturned rim (2A.18d) are only sporadic.

Among the most representative shapes (see Diagram 1b, from type 2A.17b to type 2A.18a) we find some varieties of thin walled bowls, simple, with hemispherical body (types 2A.1a and 2A.1b) or with vertical, pointed rim (type 2A.2). Most frequent, however, are the medium and medium-large bowls with convex upper sides of type 2A.18a, of which a smaller variant is also quite well attested (type 2A.17b).

Despite some varieties in shapes and fabrics, which, to some extent, might reflect chorological or functional differentiations, the group of drab ware is relatively homogeneous. Close similarities are, however, visible with the more general group of the plain ware. The drab ware is to be interpreted within the common ceramic production, and suggests a rapid and, to some extent, mass production system.

References

Pl. 18: 1, K08.776, K08.1019, K08.897; Pl. 18: 2, K08.1085, K08.1096; Pl. 18: 3, K08.1177, K08.827; Pl. 18: 4, K08.764, K08.1583, K08.1035, K08.363; Pl. 18: 5, K08.348, K08.362a; Pl. 18: 6, K08.1197; Pl. 26: 5 K09.911; Pl. 31, K08.1019, K08.1085, K08.271; Pl. 32, K08.1019; Pl. 33, K08.362a

Fig. 2: 30 (K12.1957, type 1H.2), 32 (K08.1132, type 1H.3); Fig. 3: 38 (K08.1019, type 2A.1a), 44 (K12.820, type 2A.1b), 50, 58, 62 (K12.2133+2134, K08.1303, K08.415, type 2A.2); Fig. 4: 69 (K08.779, type 2A.4a), 74-75 (K08.1213, K08.784, type 2A.4d), 84 (K08.348, type 2A.9); Fig. 5: 87 (K08.362a, type 2A.10), 91 (K08.925, type 2A.11a), 93 (K09.911, type 2A.11b), 95 (K12.2041, type 2A.11b), 97, 100 (K12.2143, K12.1937, type 2A.11c), 104 (K08.697, type 2A.11e), 109 (K08.454, type 2A.4a); Fig. 6: 123, 125, 126 (K08.787, K08.1096, K12.9, type 2A.17a), 136-139 (K08.1239, K12.2142, K12.981, K08.369, type 2A.18a); Fig. 7: 140-143 (K08.2100, K08.1517, K08.764, type 2A.18a), 145 (K08.363, type 2A.18b), 147 (K08.1748, type 2A.18c), 149-150 (K12.1581, K08.418, type 2A.18d), 151-154 (K08.387, K09.1074, K08.396, K08.428, type 2A.18e); Fig. 8: 171 (K08.298, type 2A.20a), 174-175 (K12.819, K08.817, type 2A.20b), 182 (K12.336, type 2A.20e); Fig. 10: 234 (K10.56, type 2B.2a)

2.2.3.4 Glazed Ware [Gl]

The inventory of glazed ware is limited to 6 rather small potsherds, which were found between the upper slopes of the höyük and the lower terrace. Most of the recovered samples (4 sherds) present the same variety of green glaze (Pl. 33, K12.30). Of these, one is a fragment of a disc based bowl, while the others are simple body sherds. Three were recovered on the southern upper slopes of the höyük (Lot 9, Bands 1 and 2), and one on the lower terrace east (survey unit J19). A single sample of body sherd, recovered on the north-western sectors of the lower terrace (survey unit L5) presents a reddish brown glaze. A small fragment of a ring base bowl was found on the lower terrace east (survey unit L9), and is characterized by a white glaze with blue decorative patterns covering both the outer and inner surfaces (K09.960, Fig. 32: 576; Pl. 33). The fabric is quite a fine and depurated, well fired and of homogeneous buff colour (7.5YR 7/4, pink). The texture, however, is rather porous, with sandy appearance. The green and brown glazed samples, instead, have a coarser sandy fabric, red or light red in colour (2.5YR5/6, red, or 2.5YR 6/8, light red). While the white and blue glazed sherd may be related to the fine wares production, the green glazed samples seem closer to the common wares.

References

Pl. 33, K09.960, K12.30

Fig. 32: 576 (K09.960, type B5)

⁴⁷ In this case, the established parameters for attribution to the drab ware group were not fully satisfied, but these bowls may be considered borderline examples. However, space is left for future revision of the parameters, should stratified materials be recovered. It is worth noting, in fact, that an attribution to the drab ware group includes a specific chronological attribution, and, since here we are dealing with surface samples, we decided to apply very strict parameters. The nature of the UHSP morphological inventory of drab ware, which includes almost exclusively open shapes, is also affected by the choice of parameters. It is likely that closed shapes might also have pertained to the same ceramic production but, to all appearances, the sections of the vessels retained for diagnostics (that is, rims or rims plus necks), did not show comparable attributes in terms of appearance and comparisons.

2.2.3.5 *Gold Wash Ware [Gw]*

A small group of sherds probably pertains to a production known in archaeological literature as Gold Ware (Bittel 1937: 37; Gorny 1995, 162, 164 and fig. 12), Gold Wash Ware (Matsumura 2005: 123-24) or Gold-mica Ware (Schoop 2011b: 260; Mielke 2006: 27, 39-41).

These are characterized by a thin coat of glistening gold-coloured particles, most probably mica⁴⁸, thin walls and very fine fabric.

The sample from Uşaklı survey is limited to 5 pieces. Of these, one is a body sherd, while the other 4 are rim sherds of carinated bowls with slightly everted upper section (Fig. 10: 223, 225 and Pl. 26: 2 K08.1086, K08.1606, shape type 2B.1).

Among the bowls, two different types have been observed (see Pl. 31, K08.1086 and K08.1606).

The gold wash is most evident in bowl K08.1086 (Pl. 31, Fig. 10: 223). The surface of the upper section of the bowl, both outside and inside, is entirely covered with glistening gold coloured particles, apparently applied together with a thin, clear buff slip. The glistening wash, instead, is slightly less marked on the outer lower section of the bowl surface. The fabric (fabric type 16) is homogeneously red, with very fine texture, very dense and very well sorted. No inclusions are visible to the unaided eye.

The other bowls are slightly different in terms both of surface finish and of fabric. The surface of the sherd K08.1606 (Pl. 26: 2, Pl. 31) presents a cream slip, on which glistening gold colour particles are sparsely found. The surface treatment of K09.1140 (Fig. 10: 225, type 2B.1) is not perfectly preserved: large spots of whitish incrustations are found over the outer surface and cover most of the inner surface. However, among the spots of the inner surface which are free from incrustations, a clear slip (7.5YR 8/2, pinkish white), rich in glistening particles, is unmistakably visible. Instead, only a very thin, almost transparent wash covers the outer surface, letting the colour of the reddish matrix below show through.

The presence of an additional white or cream slip has already been recorded at other sites, but it is considered rarer: in most cases, in fact, the glistening wash is directly applied over the surfaces (Schoop 2011b: 260).

The fabrics are very fine, with fine texture, very dense and well sorted. A few small and very small white inclusions, however, are visible to the unaided eye and, unlike K08.1086, where the gold wash was more evident, these two other samples present a sandwich fracture, with buff (K08.1606) or orange margins (K09.1140) and greyish core.

The difference between the two groups might be explained in terms of their state of preservation, but the fact that a difference is visible also in the fabrics (as also, thought to a lesser extent, in shapes)⁴⁹, makes us consider the possibility of two distinct variants. The sample analysed is, however, too small to permit any firmer conclusions.

The perishable nature of the gold wash recognized at other sites (Schoop 2011b: 260) finds confirmation at Uşaklı: in our case, the wash appears best preserved on the inner surface of bowls, and especially at the junction between lower and upper section.

On the basis of the published examples from different sites in central Anatolia⁵⁰, D.P. Mielke suggests a date range from the Old-Hittite period to the early Imperial (Mielke 2006: 41), while a slightly earlier range is given by U. D. Schoop, essentially limited to the first half of the Hittite ceramic sequence (Schoop 2011b: 261). At Kaman-Kakehöyük, however, wares that seem to be related to the gold wash ware are reported also in 1st millennium BC (Matsumura 2005: 123-124)⁵¹.

The type is thought to have been imported into Central Anatolia (Matsumura 2005: 123-124): the precise area of origin is not known, but general connections are suggested with southwestern Anatolia productions (Schoop 2011b: 261).

This is obviously a fine ceramic production. An intentional parallel with sheet metal vessel is thought to be most likely, probably more evident at the time in which the vessels were in use, when the glistening gold appearance would have been more marked (Schoop 2011b: 261)⁵².

⁴⁸ For discussion and earlier literature see Mielke 2006: 27, and Matsumura 2005: 123-124.

⁴⁹ K08.1086 (Fig. 10: 223) is slightly larger and the section above the carination is slightly longer than in the other examples, which correspond better to Fig. 10: 225.

⁵⁰ Mainly Büyükkale (Bittel, Güterbock 1935; Neve 1982: 36), Bogazköy (Bittel 1937: 37; Fischer 1963) and Alishar (Gorny 1995: 162).

⁵¹ Namely, two variants are reported for Iron Age Kaman-Kakehöyük: one with evident gold coloured particles, and a second with gold coloured particles invisible to the unaided eye.

⁵² For extensive analysis and comparisons see Matsumura 2005: 123-124, and Mielke 2006: 39-41.

References:

Pl. 26: 2 (K08.1086, K08.1606), Pl. 31 (K08.1086, 1606)

Fig. 10: 223 (K08.1086, type 2B.1, Pl. 26: 2), 225 (K09.1140, type 2B.1), K08.1606 (Pl. 26: 2, Pl. 31, type 2B.1)

2.2.3._c Grey Ware [G] [Gp] [Gr]

A relatively small inventory of grey wares has been found. Monochrome grey wares are typical of Western Central Anatolia in the Middle Iron Age period (Genz 2011: 346-349), and grey burnished wares are typical of Late Iron Age Periods (Genz 2011: 349). The sample from Uşaklı Höyük clearly does not pertain to a single tradition: different fabrics and surface finishing have, in fact, been observed. To this group we have attributed the sherds with grey surface and fabric, indicative of a reduction firing. The surface of most of the samples is at least partially polished or burnished, but simply smoothed surfaces are also attested. The fabrics vary between very fine and coarse texture, mainly of grey colour⁵³. Two main distinctions have been made between a finer variant, indicated as grey ware [G] and a coarser one, indicated as grey rough ware [Gr]. A few samples have been isolated that present some painted patterns and are classified as grey painted ware [Gp]: most of these, however, are also related to the group of the painted wares.

Surface colours range from light grey (5Y 6/1, grey) and light brownish grey (2.5Y 6/2 light brownish grey, see Pl. 21: 4, K09.491) to grey (10YR 5/1, grey) and darkish grey (Gley1 4/N, dark grey).

As far as fabrics are concerned, both very fine and rough samples are relatively few. The majority of the samples is divided between medium sandy fabrics and medium grit fabrics.

Among the finer variants, a minority of examples has a polished darkish grey surface (Gley1 4/N, dark grey) and very fine plastic fabric, with no visible inclusions (fabric type 16)⁵⁴. Small glistening particles and white flakes, instead, characterize the fabric of the ring base K09.51 (Pl. 21: 4, type B5, grey painted ware). The upper surface is unevenly polished. In the preserved portion, the light grey colour of the surface (2.5Y 7/1, light grey) is limited to a wide circular band between darkish grey painted sections (5YR 3/1, very dark grey), probably other bands⁵⁵. The motif recalls the typical pattern of the so-called 'Galatian Ware' and the sherd is, therefore, probably to be attributed to the same ceramic horizon.

A sporadic example is also the grey ware painted sherd K12.2 (Fig. 5: 89), with polished surface.

A larger group presents a grey or light grey surface, lightly polished/burnished, and fine, compact fabric, with only small visible inclusions, mainly mineral in nature (K09.1138, Pl. 32, Pl. 21: 4). Also K09.65 (Pl. 21: 3, type 2A.2) has a fine plastic fabric with only a few very small white inclusions visible. The colour of the matrix, however, is not grey but homogeneously brownish (10YR 4/2, dark greyish brown), suggesting closer similarities with the group of the plain ware.

Coarser samples usually have simply smoothed surfaces (K09.616, Pl. 21: 4; Pl. 32) or coarsely polished surfaces (K09.1032, Pl. 21: 4). The fabric (Pl. 32, K09.616) is medium/medium-coarse, with a high frequency of medium and small mineral inclusions, mainly white. Quite abundant also are silver coloured glistening inclusions, of medium-small to small in size, angular and flattened.

A large section of the inventory has medium or also medium/fine grit fabric, with a high frequency of visible mineral inclusions of small and medium size (Pl. 21: 4 K09.574, K09.868; Pl. 32, K09.806). They largely consist of white, angular grits. Small grey grains are also quite frequent, as well as small sparkling particles. The density of these fabrics is usually quite high and the colour is light grey. Some similarities are visible with some coarse grained ware fabrics. The fabric of K09.806 (Pl. 32), in particular, seems quite close to the fabric type 10.8 (Pl. 31, K09.209), typical of the grey and yellowish variant of the coarse grained ware. In fact, it shows similar matrix colours (light grey and buff), relatively high density and a main range of mineral inclusions, consisting mainly of white, angular and flattened grits, grey grits and clear flattened particles. The surface of the sherd is well smoothed and presents burnished stripes alternated with unburnished sections, creating a decorative effect. Another sizeable group of sherds with medium grit fabric is characterized by minor frequency of inclusions, but these are larger in size (Pl. 32, K09.762). These consist mainly of white and whitish angular grits, moderate

⁵³ Many examples are attested with grey or greyish burnished surface and buff of light brownish fabric, but in this case they have been sorted into the group of plain ware, (see, for example Pl. 21: 4, K09.378, Fig. 22: 471).

⁵⁴ The reference for this group is K12.360, type 2B, not shown.

⁵⁵ They are most probably painted concentric bands, but the preserved section of the vessel is not large enough to make out the lower and upper margins.

frequency of white rounded inclusions and silver coloured sparkling flakes. Additional grit variants are visible on the close-ups of the cross section, and not detectable at x5 magnification, like angular grits of grey or clay colour. The surface is roughly polished.

A last sub-variant (K09.1272, Pl. 21: 3, Fig. 10: 220) includes sherds with medium sandy fabric, characterised by medium or medium/high frequency of small rounded, white inclusions, corresponding to the general fabric type 2. The surfaces are generally well burnished.

K12.447 (Fig. 35: 670, type 6B) is an atypical sample. Both surface and fabric have a very light grey colour. It has a fine fabric, with very high density, and medium frequency of visible small and medium-small inclusions. The main inclusions are small white and grey particles. Sporadic white lumps are also visible, together with sparkling particles. The surface is highly polished, but the small section preserved does not enable us to determine whether it was handmade or wheelmade. The shape, however, is far more common among handmade ceramics.

As with fabrics and surface finishing, the range of shapes is also quite varied. Most of the grey ware samples pertain to body sherds, while diagnostic sherds pertain to simple bowls with convex upper sides (Fig. 4: 72), with outer thickened, tapered rim (Fig. 5: 102) or with inner thickened, squared rim (Fig. 6: 115); curved bows with outside pointed rim (Fig. 8: 164); S-shaped bowls (Fig. 10: 220); carinated bows with upper vertical sides (Fig. 11: 251) or with outer thickened, squared rim (Fig. 13: 306); high necked jars with thickened, squared rim (Fig. 20: 450) and shape types ZA (Fig. 35: 670). A single example is attested of a body sherd with a decorated band of excised triangles (Fig. 34: 637, Pl. 21: 5, K12.1513).

With the exception of a few sherds, most of the grey ware is to be interpreted as falling within the common ware production.

References

Pl. 21: 3, K09.1272, K09.65; Pl. 21: 4, K09.491, K09.868, K09.776, K09.51, K09.574, K09.1138, K09.616, K09.1032; Pl. 21: 5-6; Pl. 32, K09.806, K09.762, K09.1138, K09.616

Fig. 4: 72 (K12.41, type 2A.4b); Fig. 5: 102 (K12.556, type 2A.11d); Fig. 6: 115 (K12.14, type 2A.14e); Fig. 8: 164 (K12.200, type 2A.19c); Fig. 10: 220 (K09.1272, type 2A.30); Fig. 11: 251 (K10.130, type 2B.2c); Fig. 13: 306 (K12.216, type 2B.12a); Fig. 20: 450 (K12.254, type 6C.7); Fig. 28: 530 (K09.776, type ZA.10); Fig. 31: 571 (K08.1024, type B5); Fig. 34: 637 (K12.1513); Fig. 35: 670 (K12.447, type 6B)

2.2.3., Kitchen Ware [K]

A series of examples are ascribed to the group of kitchen ware as they were probably intended to be used on fires, an assumption essentially based on technological and morphological characteristics associated with specific traces of fire. Traces of fire and/or darkened surfaces constitute the key feature. A range of recurring colours, surface treatments and fabrics has been identified but this is not entirely distinctive as many of the traits are also shared by other large ceramic classes, like plain and drab wares. The fabrics are mainly sandy, with medium/medium-high frequency of visible inclusions. Inclusions are mineral in nature and most often medium/medium-small in size. The surface treatment is rather coarse and the surfaces are mainly uncoated, although a sort of self-slip seems to be present in some samples. They appear un-smoothed and are rough to the touch. The recovered samples are predominantly wheelmade.

The range of surface colours is quite wide, varying from different nuances of grey to different brownish shades, with light brown variants (7.5YR 6/3, light brown), being among the most frequent. Completely darkened samples are also attested (Fig. 18: 386, Pl. 21: 1, K08.1579, K08.761). The fractures have frequently a sandwich appearance: the colour of the clayish matrix is reddish or brownish, while the core is grey.

Most of the kitchen ware fabrics, exception made for the sporadic presence of very large grits, are not substantially different from other fabrics found in red slip or drab ware sherds. The range of visible inclusions in fact is reasonably similar, key differences lying mainly in their frequency and ratio. The frequency of inclusions is, in fact, mainly medium-high/high. Major visible inclusions are the white and whitish particles, from small to medium size, and clear, sparkling inclusions. Minor inclusions consist of small, grey inclusions and different kinds of large size grits.

Two main groups have been observed. Coarser variants (fabric type 20 and 20.1) are characterized by a high frequency of small mineral inclusions, mainly white or clear, and of medium-large grits, mainly white and whitish. Finer variants (fabric types 20.2 and 20.3) have medium grit or sandy fabric which, to the unaided eye, appear quite similar to that of drab ware sherds, characterized by medium or medium-high frequency of small and very small white inclusions and clear, sparkling particles.

The first category mainly includes pots with outside thickened, pointed rim and thickened band over the shoulder (shape type 5A.8a, Fig. 18: 385-386; Pl. 21: 1, K08.618, K08.1579). They have a medium-coarse sandy or gritty fabric, with medium-coarse texture, medium-low density and poor sorting. There are abundant mineral inclusions and medium-high frequency of white and whitish grits of medium size. Clear, glistening medium-small flakes are attested with a medium-high frequency. Large and very large grits are sporadically recorded. An average high frequency of sparse large and very large grits is attested in large pots with thickened, pointed rim of type 5A.6 (Fig. 17: 378-379, K09.600, K12.16) and 5A.7 (Fig. 18: 383-384, K08.772, K08.1056). A marked coarse temper recurs in pots with outside thickened, rounded rim of shape type 5A.3. It is characterized by medium-coarse/coarse texture, low density, poor sorting and a high frequency of grits, chiefly large white and whitish grits and sparse large grey grits.

Finer fabrics are found in low necked jars of type 6B.2 (Fig. 19: 411). They have sandy fabric, with medium or medium-fine texture, medium density and fair or poor sorting. Visible inclusions vary from medium-low to medium-high frequency, usually of small size. Major inclusions consist of small and very small white inclusions, attested from low to medium high frequency, and small clear glistening particles, usually attested in high frequency. Minor inclusions comprise small, whitish and darkish grey inclusions of rounded shape.

The thickness of the walls varies in accordance with the variations in vessel size.

Among shapes, those that recur most frequently are pots with outside thickened rim, with either rounded or pointed profile (shapes type 5A.2-8a). Medium-small neckless jars with everted rim (shape type 6A.1a) or outside thickened rim (shape type 6A.3), and medium-small jars with short neck (shape type 6B.1-2, 4-5) are also quite frequent. Fairly small vessels, almost intermediate between bowls and small pots (shapes types 5A.9, 5A.12) are only found occasionally. Most of the large, simple plates of shape type 1A, plates with large thickened rim of type 1B as well as most of the simple plates with rope impression (shape type 1G) also pertain to the kitchen ware category.

Overall, the group of the kitchen ware is not completely homogeneous, probably indicating the presence of different traditions and to be related to different chronological horizons. A relatively quick process was used to produce them.

References

Pl. 19; Pl. 21: 1-2; Pl. 33, K08.2205, K09.1242, K08.1816, K08.1995, K08.1

Fig. 1: 1-3 (K12.639, K12.2045, K12.894, types 1A), 4 (K08.1904, type 1A.2); 6 (K12.1998, type 1A.3), 8 (K08.2000, type 1B), 9-13 (K09.382, K09.755, K08.2202, K12.1877, K12.1843 type 1B), 14-15 (K08.2201, K08.430, type 1C); Fig. 2: 16 (K09.934, type 1C), 18 (K08.2205, type 1D), 21 (K09.859, type 1F), 22-28 (K09.279, K09.106, K09.49, K12.750, K12.1464, K12.397, K12.1038 type 1G), 29 (K08.1302, type 1H.1); Fig. 5: 105 (K12.895, type 2A.11e); Fig. 6: 127 (K12.896, type 2A.17a); Fig. 16: 358 (K08.44, type 3A.3); Fig. 17: 364 (K12.174, type 5A.1), 366-367 (K12.175, K08.906, type 5A.2), 371-372 (K09.901, K09.184, type 5A.3), 374-375 (K08.767, K08.551, type 5A.4), 376 (K12.481, type 5A.5), 378-379 (K09.600, K12.16, type 5A.6), 382 (K08.426, type 5A.7); Fig. 18: 383-384 (K08.772, K08.1056, type 5A.7), 385-386 (K08.618, K08.1579, type 5A.8a), 390 (K08.1995, type 5A.9), 393 (K09.599, type 5A.10), 396 (K08.775, type 5A.12); Fig. 19: 398 (K09.925, type 6A.1a), 402 (K12.100, type 6A.3), 407-410 (K09.792, K12.29, K12.96, K12.293, type 6B.1), 411 (K08.19, type 6B.2), 417-418 (K12.291, K12.99, type 6B.4), 422-423 (K12.63, K12.97, type 6B.5).

2.2.3._g Orange Slip Ware – [Os]

The orange slip is a very fine ware, characterized by orange fabric and surface.

No variation is registered among the fabrics of the sherds pertaining to this ware, all classified within fabric type 16. They are characterized by fine texture, medium-high/high density and very good sorting. It is quite well depurated, with sporadic visible inclusions. To the unaided eye, only very small white particles are sometimes visible, with sporadic frequency. Small voids of irregular shape, mainly elongated, are also sporadically registered (Pl. 29, K08.287).

The sherds appear perfectly oxidized: the colour of the fracture is always homogeneously orange, indicative of a good firing process. In terms of the Munsell soil colour chart, the fracture is 5YR 6/6 (reddish yellow).

The colour of the surface is usually quite close to that of the matrix, but different shades are attested, ranging from orange to reddish orange (5YR 6/8, reddish yellow; 2.5YR 5/8, red). Surfaces seem to be slipped, a sort of thin, watered coat being visible in most cases. The surface appearance may be either

dull or partially glossy, but it is always well vitrified and non-porous. It frequently presents evident traces of fast throwing, but burnishing is also attested. The burnishing is usually irregular, appearing in the shape of horizontal stripes that do not cover the entire surface. Usually the burnished stripes are alternated with close throwing lines. In the interior of bowl K09.944 (Pl 26: 1; Fig. 4: 77) traces of two different burnishing activities are attested. A first burnishing activity has been executed with a thin instrument, obliquely applied; a second burnishing activity, which partially obliterates the first, has been executed with a slightly larger instrument, horizontally applied.

A slightly different variant is attested that is characterized by the presence of mainly dull dark reddish brown slip. The colour of the slip, probably as a consequence of changing firing conditions, may vary over the surface of a sherd from dark reddish brown, to reddish brown and red (2.5YR 3/1, dark reddish grey; 2.5YR 4/4, reddish brown; 10R 4/8, red) (K09. 900, Fig. 4: 80, type 2A.6; K09.971, type 2A.6). With the exception of the surface colour, however, the other technological and morphological properties are coherent with the group of orange slip ware, suggesting that this variant pertains to the same production horizon. The surface finish of this second variant is, in fact, the same as that of the main group: fabric types and colours are perfectly coherent, as it is the morphological range.

The range of attested shapes is limited to conical bowls with simple, rounded rim and flattened base (K09.944, Fig. 4: 77, type 2A.5) and conical bowls with thickened rim (Fig. 4: 79-80, K09.370, K09.900; Pl. 26: 1; K08.287, Pl. 17: 2 and Pl. 29; K09.487⁵⁶, type 2A.6). Very small, curved bowls with outside thickened rim (K09.986, Pl. 26: 1) are sporadic, as are thin, curved bowls with pointed rim of type 2A.2 (K09.112, Pl. 26: 1, type 2A.2).

Slightly dubious is the attribution to the same group of bowl type 2A.2 (K09.1122, Pl. 26: 1) which, given the well burnished/polished surface finish appears intermediate between orange slip ware and orange ware.

Some doubts arise also regarding the attribution of bowl K09.953 (Pl. 26: 1; Fig. 4: 78) and of K09.1225 (Pl. 26: 1; Pl. 29). The bowl presents a slightly different range of both matrix and surface colours, mainly darker than the classical orange slip ware, but surface finish and matrix type seem coherent with the group. K09.1225, instead shows the same range of colour as classical orange slip ware, but has a slightly coarser fabric, sandier and with a higher frequency of small, white mineral inclusions (Pl. 29).

With the exception of the presence of a single variant distinguished by the colour of the slip, the group of orange slip ware appears quite homogenous, reflecting a standardized production. The quality is very high, relating to the fine wares production.

Comparable variants of fine red and brown wares are recorded in stratum 6 of Alişar Höyük, where they are related with the *terra sigillata* or pseudo-*sigillata* (Schmidt 1933, 101)⁵⁷.

In terms of the UHSP ceramic inventory, close similarities are visible with the group of orange wares.

References:

Pl. 17: 2 (K08.287); Pl. 26: 1; Pl. 29 (K08.287, K09.1225)

Fig. 4: 77 (K09.944 type 2A.5), 80 (K09.900 type 2A.6)

2.2.3., Orange Fine Ware [O]

Under the general label of orange ware, a limited group of sherds has been sorted which present many similarities with those described here above and assigned to the category of orange slip ware.

The orange ware is a very fine production, characterized by deep orange/red surface and fabric (2.5YR 5/8 or 4/8, red). The surface is not slipped, but it is usually perfectly smoothed and well burnished, non-porous and with a glossy appearance.

The fabric is very fine and depurated (fabric type 16). The texture is very fine, with high density and very good sorting. With the exception of very small and sporadic white particles, no inclusions are visible to the unaided eye. Small irregular voids are sporadically attested (K08.556, Fig. 31: 581; K10.134).

Most of the sherds pertaining to this category consist of generic body sherds, whereas the number of diagnostic sherds is quite restricted. The range of attested morphologies is, in fact, limited to a conical

⁵⁶ Not shown.

⁵⁷ Together with the fineness of the fabric, a direct correspondence between Uşaklı Höyük orange slip ware and the red and brown fine wares of Alişar Höyük is proved by the surface appearance, showing 'various shades due to the varying thickness of the pigment coating, conditioned by the irregularities of the wheel-marked surface' (Schmidt 1933: 101).

cal pedestal base (K08.556, Fig. 31: 581, base type B7) and to a handle with rounded-flattened section (K10.134, handle type 13).

The colour of the fracture is perfectly homogeneous, mainly orange/red (2.5YR 5/8, red) indicating completion of the oxidation process. Considering the high density and fine grain of the fabric, the homogeneous red colour of the fracture and the scarcity of pores all denote accurate mixing and forming processes, as well as good firing technology. Altogether, the use of a depurated matrix, the high level of technology applied in the firing, and the time-consuming surface finish indicate a special production within the horizon of fine wares.

As far as we can tell from the recovered sample, the production is quite well standardized.

Some doubts arise in attributing some of the sherds that have the same surface appearance as classical orange ware samples but show a definitely coarser fabric. In K09.1225 (Pl. 26: 1, Pl. 29, shape type W), in addition to small white particles with medium frequency, small greyish inclusions and micaeous particles are also visible. K08.312 (shape type ZA.3b), instead, has a definitely gritty fabric (fabric type 10). The range of shapes is different from that of orange ware proper, but the small size of the sample prevents any more certain evaluation. Given all of these factors, we are dealing here either with a variant within the same production, or a different production.

Close connections are visible between the orange ware and the orange slip ware. There are, however, some marked differences in surface finish, fabrics and colours⁵⁸, thus denoting a different production.

While the orange slip ware could be considered of 'late' date in virtue of its resemblances with Roman *Terra Sigillata*, the orange ware may correspond to one of the red fine wares already identified at many sites in the region and characteristic of the second millennium BC. In particular, technological aspects and morphological range point to the Red Lustrous Wheelmade Ware⁵⁹. This kind of pottery, in fact, is characterized by very fine and compact fabric, almost without visible inclusions, bright orange colour and well-levigated surface. Slightly coarser variants have been detected through laboratory analysis. It is widely distributed in the eastern Mediterranean during the Late Bronze Age, and the bulk of finds in Central Anatolia, where it appears around the beginning of the 15th century, date to the 14th and 13th centuries BC. The low number of shapes attested in the region, almost limited to spindle bottles and libation harms, supports the hypothesis of a non-local production whose original manufacturing centres, on the basis of mineralogical studies, should be sought on the south Anatolian coast and in northern Cyprus⁶⁰.

References:

Fig. 31: 581 (K08.556 type B7)

2.2.3.₁₀ *Painted Wares*

Among the family of painted wares, a main distinction has been made between handmade painted wares, mainly pertaining to the so-called 'Cappadocian Ware' horizon, and wheelmade painted wares, mostly to be located within the ceramic horizon of the 1st millennium BC. Whereas the group of handmade painted wares is quite restricted and relatively homogeneous⁶¹, the group of wheelmade painted ware is rather large and heterogeneous both in terms of technology and of decorative patterns.

2.2.3._{10.1} *Wheelmade Painted Wares [Pt]*

On the basis of recurring finishing techniques, fabrics, colours of the surface and of the paints, a set of ten large groupings has been distinguished.

In principle, the more a group is internally homogeneous and divergent from others, the greater is the likelihood that it will reflect a distinct ceramic production, in terms of chronology, function and/or

⁵⁸ The orange slip ware is most probably slipped, with alternate glossy and dull appearance, whereas the orange ware is more probably bare, with extended glossy areas. Orange slip ware fabrics are slightly less dense than those of the orange ware, while the colours of orange ware surface and fabric are slightly darker than those of the orange slip ware.

⁵⁹ The recovered fragments belong, in fact, to a pedestal base and to a handle with rounded-flattened section, which could pertain to a spindle bottle, one of the typical shapes in Red Lustrous Wheelmade Ware. The recovery during the 2013-2015 seasons of other orange ware sherds pertaining to tubular bodies, carinated shoulders, tapering neck and thin disc-shaped rim, seems to confirm the hypothesis that Uşaklı Höyük orange ware is to be identified with the Red Lustrous Wheelmade Ware group.

⁶⁰ On Red Lustrous Wheelmade Ware, see in particular Eriksson 1993; Kozal 2003; Mielke 2007 and Manuelli 2009.

⁶¹ See § 2.2.3._{17.1}, *Handmade Painted Ware [Pt-Hm] [C]*.

culture. Inversely, internally heterogeneous groups or different groups sharing several elements would more probably reflect different ceramic productions, more or less similar to each other.

Group 1

A first group has been identified which is characterized by a yellowish slip and a monochrome, blackish paint (Pl. 23: 1). A slight difference has been noted between very pale slips (Pl. 23: 1) and deep buff slips (Pl. 23: 6). Among very pale slip sherds (see spec. Pl. 23: 1, K09.781 and K09.320), the colour of the slip ranges from light grey (10YR 7/2, light grey) to very pale brown (10YR 8/2, very pale brown). In a few cases, it is almost whitish (2.5YR 7/1, light grey) (see as example K09.727, Pl. 23: 1). The quality of the surface treatment may vary: usually it is smooth to the touch. The finishing, however, is dull.

Among deep buff slip sherds (see spec. Pl. 23: 6, K09.309, K10.224, K10.125 and K09.621), the colour of the slip is typically very pale brown (10YR 7/4), and the surface is usually burnished or lightly polished, resulting in a glossy appearance. The paint, instead, is always dull. In fact, it is always found above the burnished slip, indicating that the vessels were painted after the surface had been burnished/polished.

A number of intermediate samples are attested whose slips are close to the 'very pale brown' (10YR 7/3) (Pl. 23: 1, K09.796, K09.620, K09.1109, K09.750, K09.537, K09.1104) or 'pink' (7.5YR 7/3) (Pl. 23: 1, K09.789; Pl. 23: 6, K08.990) in the Munsell soil colour chart. The surface treatment may vary, but it usually includes at least partial burnishing/polishing.

The paint is usually thick and dull, of blackish or darkish brown colour (7.5YR 4/1, dark grey; 7.5YR 2.5/1, black; 7.5YR 3/2, dark brown).

Painted motifs are primarily geometric. They seem to be quite strictly linked to the morphology of the vessel, of which they emphasize the volumetric sections. The painted pattern has a high decorative value. One of the very few elements evoking natural or descriptive spheres, possibly part of an antler, is found on K10.224 (Pl. 23: 6). However, as far as we can estimate from the small sherd preserved, it seems used in a decorative sense, as are the concentric circles which are next to it, all of them inscribed within bands of neat, parallel lines.

The most common elements are bands of parallel lines or stripes. These may be found alone, marking the different sections of the vessel (K09.796), or as the basis of more complex patterns (K10.224). When found alone they are usually thicker, ranging from medium (4.5mm, see Pl. 23: 1, K09.796) to medium-large width (8 or 8.5mm, see Pl. 23: 1, K09.1109 and K09.620). When they are combined in more complex designs, they are thinner (2mm, see Pl. 23: 6, K10.224, K09.309; 1.5mm, see Pl. 23: 1, K09.789, Fig. 12: 275), and more precise. In this case they frequently serve as the base on which the space is structured. Parallel short strokes (Fig. 8: 187; Fig. 28: 529), or short strokes alternated with solid rectangles (Fig. 9: 204; Fig. 27: 520) are frequently found on the upper profile of the rims in thickened rim bowls, small jars (Fig. 16: 362), or possible craters (shape type ZA). Triangles and chevrons are found on closed shapes (Pl. 23: 1, K09.320 and K09.485). Concentric circles are usually located between bands of thin, parallel lines (Pl. 23: 6, K10.224, K09.799), and are found on the outer surface of closed shapes. Thin wavy lines, resting on straight parallel lines, are typically located along the outer and inner rim of the small bowls (K09.789: Pl. 23: 1, Pl. 23: 3, Fig. 12: 275) or on carinations (Pl. 23: 1, K09.1104). Exceptionally they have also been found close to the base section (Fig. 31: 562). Coarser wavy lines are found on the inner/upper profiles of the rim of shapes type ZA (Fig. 27: 518). Crossing lines forming hatched triangles decorate large handles (Pl. 23: 6, K08.990), whereas smaller handles with rounded section are decorated with parallel and perpendicular lines alternated with solid painted spaces (Pl. 23: 6, K10.225). Triangles with an elongated cathetus are a variation of triangle motifs. If compared with the so-called silhouette cluster, typical of Alişar IV⁶², they appear very close, in term of style, to some of the distinctive animal profiles⁶³. As with the classical animal silhouettes, they decorate large craters (usually two-handled in the parallels) with grooves on the inside of the rim. However, while Alişar IV animal silhouettes are mainly located on the shoulders of the vessels, the triangles with elongated sides are essentially located on their large necks, emphasizing the verticality of this section of the vessel⁶⁴.

The sherds K12.408 and K12.409 (Pl. 25: 5) present a more complex pattern. The theme is based on the crossing of bands and lines creating rhomboidal shapes and frames. These are alternatively left

⁶² See cited references in Genz 2001: 160.

⁶³ See as example Alişar, Schmidt 1932: Fig. 323; Schmidt 1933: Figs. 421-424.

⁶⁴ The animals depicted on the so-called silhouette style are most frequently stags and wild goats, often surrounded by concentric circles. They are usually in dark, matt paint, located on the shoulders of large craters with grooves on the inside of the rim (Genz 2001: 160).

blank, covered with paint, covered with other motifs of crossing lines (forming a *quadrillé*) or bands (forming a chess motif), or further divided into other frames and spaces. This compositional scheme is more frequent in other groups of painted wares, but the surface finish (yellow slip and blackish paint, smoothed but dull) is closer to group 1.

The fabric of medium thick sherds is mainly gritty, with an abundance of white and clear white inclusions, usually small/medium-small and with greyish inclusions, both small and dull or flattened and glistening, and micaceous particles. Among other inclusions reddish-brown grits may be attested. On the whole, fabrics are of medium texture, with medium/medium-low density and poor sorting. Fabric type 10.2 is quite common. Finer pastes are, however, attested, characterized by medium-fine texture, medium-high density and good/fair sorting (Pl. 23: 6, K10.28). The fabric is similar in thinner walled sherds, characterized by a lower frequency of inclusions. A different fabric (fabric type 17.1) is registered for the small bowl K09.789 (Pl. 30; Pl. 23: 3; Fig. 12: 275), with finer texture. The colour of the fracture is frequently homogeneous, reddish (5YR 6/6, reddish yellow; 2.5YR 5/6, red) or brownish (7.5YR 5/4, brown); a more brownish nuance may be registered on the inner margin, but on the whole the firing seems to be of medium to high accuracy. Extensive greyish cores indicative of inaccurate firing are, in fact, rare.

Overall, the group of blackish painted wares points to at least two distinct productions: one coarser and another more refined. Apart from this distinction, the two productions show a medium, medium-high degree of standardization. The inventory of small bowls constitutes the finest example, but the group is mainly to be related to a common ceramic production.

Clear connections are visible with the decorative patterns of group 2 and 3. The colour of the paint is the same found in some variants of group 4.

References:

Pl. 23: 1, K09.781, K09.320, K09.727, K09.796, K09.620, K09.1109, K09.750, K09.537, K09.789, K09.1104; Pl. 23: 3; Pl. 23: 6, K09.309, K09.621, K10.224, K10.225, K09.799, K10.28, K08.990

Fig. 8: 189 (K12.342, type 2A.22b); Fig. 9: 204 (K08.649, type 2A.27a); Fig. 12: 275 (K09.789, type 2B.5a); Fig. 16: 362 (K12.1339, type 3A.4); Fig. 20: 444 (K09.796, type 6C.5); Fig. 27: 516 (K09.309, type ZA.8), 518 (K12.1005, type ZA.8), 519 (K10.86, type ZA.8), 520 (K12.609, type ZA.8), 521 (K12.610, type ZA.8); Fig. 28: 529 (K12.255, type ZA.10); Fig. 31: 562 (K12.615, type B1); Fig. 33: 608 (K12.1751, type H14); Fig. 34: 612 (K10.224), 614 (K08.2022).

Group 2

The second group that has been distinguished is characterized by the brownish colour of surfaces and the colour of the paint, which tends to brownish purple. It is not clear if all of the sherds assigned to this group do have a proper slip. In some cases, the presence of a coat is quite evident (see as example Pl. 25: 1, K09.1105, Fig. 28: 533; K09.773, Fig. 27: 515). In other cases the colour of the surface is quite close to that of the fabric, and it is not clear if the slight difference is given by a thin slip of the same quality as the clayish fabric, by a sort of self-slip, or by the burnishing effects that gave the pieces a glossy appearance. The colour of the surface is usually brownish (5YR 6/4, light reddish brown; 7.5YR 5/4, brown). Finishing mainly includes burnishing.

In terms of the Munsell soil colour chart, the colour of the paint is around weak red (10R 4/2) or dark reddish grey (10R 3/1 or 4/1). As with the first group, it is always dull, and usually thick. Nevertheless, more weakened samples are attested.

Among the painted patterns, those recurring most frequently are medium thick bands (around 5mm) located on the neck of jars (K09.1110, Pl. 25: 1, type 6A.1a) or of possible craters of type ZA.8 and ZA.10 (Pl. 25: 1, K09.1105, Fig. 28: 533, type ZA.10; K09.772+783; K09.773, Fig. 27: 515, type ZA.8). Unlike most of the samples of group 1, these are not vertical, but horizontal and are not particularly precise: the thickness of the trait is slightly irregular, as is the direction. Groups of thin parallel lines (K08.680, Pl. 25: 1, Fig. 28: 527) or of short strokes (K09.110) alternated with large solid and vertical bands decorate in a modular pattern the bulging rims of craters and the simple everted rim of necked jars (Pl. 25: 1, K09.1110). In association with this motif, loose wavy lines are located on the inner/upper side of craters with everted rim (Pl. 25: 1, K09.1133; K09.570; K08.680, Fig. 28: 527). Shorter, thinner and more precise wavy lines resting on straight parallel lines, already found on the small curved bowl no.275 (K09.789) of group 1, are also found on the inner side of curved bowl with S profile, under the flaring rim (type 2A.30) (K09.528; Pl. 23: 2; Pl. 25: 2; Fig. 10: 219), or in association with detached parallel lines on the inner side of bowl type 2A.19c (Fig. 8: 163). Concentric arcs of circles inscribed within straight lines are frequently associated with the short, wavy lines, and located on the inner/outer side

of the bowls with flaring rim (Pl. 5: 1, K09.528, K09.390). Similar groups of short strokes decorate the rounded upper profile of bowls with thickened rim (Pl. 25: 1, K09.269, type 2A.23), or of bowls with S profile (Fig. 10: 221). Narrow, neat horizontal lines may decorate the inner upper section of small bowls with rounded sides (K09.368, Pl. 25: 1; Fig. 3: 47, type 2A.1b). Other motifs include lozenges between bands of thin, parallel lines, located on the upper side of the rim of bowls with S profile (Fig. 10: 221), solid triangles with oblique (K09.1089) or criss-cross lines (K09.1001). Sherds with a more complex pattern of straight lines, wavy lines and concentric circles (K10.53) might be attributed to the same group.

Fabrics are less homogeneous than in group 1: they all have mineral inclusions, but the quality, frequency and rate of these is extremely variable. White, medium-sized inclusions are usually prevalent. Sporadic reddish-brown grits are also attested, but the clear and micaceous inclusions typical of group 1 seem to be only sporadic. Among recurring fabric types, the variants 12.1 and 10.6 are quite frequent, but also some finer pastes, like fabric type 5, are attested. The colour of the fracture is mainly reddish or brownish. Noticeably darker cores are not recorded, suggesting a medium-high accuracy in firing.

The group of painted wares with brownish slip and brownish purple paint suggests a lesser degree of standardization compared to the first group and, with the exception of the small bowls, a slightly 'faster' style of decoration. Apart from the inventory of the small bowls, which might be allocated to the fine wares, the group mainly reflects a common ceramic production, with visible similarities with group 1 and 3.

References:

Pl. 23: 2, K09.528; Pl. 25: 1, K09.1105, K09.772+783, K09.1133, K09.570, K08.680, K09.773, K09.1110, K10.53, K09.269, K09.655, K09.368, K09.180, K09.1089, K09.1001, K09.516, K09.528, K09.390.

Fig. 8: 163 (K12.189, type 2A.19c), 179 (K08.692, type 2A.20d), 188 (K12.920, type 2A.22b); Fig. 9: 194 (K10.81, type 2A.23); Fig. 10: 218 (K12.1334, type 2A.30), 219 (K09.528, type 2A.30), 221 (K12.757, type 2A.30); Fig. 27: 514 (K08.2021, type ZA.8), 515 (K09.773, type ZA.8); Fig. 28: 527 (K08.680, type ZA.10), 528 (K12.138, type ZA.10), 533 (K09.1105, type ZA.10); Fig. 34: 613 (K10.53).

Group 3

Within the group 3, painted sherds with reddish/reddish brown fabric and surface have been grouped. As with the second group we isolated, it is not always easy to tell with the naked eye whether the vessels are coated or not. In most cases, the surface is evenly burnished, and the glossy and un-porous aspect gives the appearance of a sort of coating. The closeness of fabric and surface colours however, together with the absence of clearer traces, obliges us to consider the possibility of a self-slip or of the absence of slip. In some cases, instead, the absence of a slip is evident.

In terms of the Munsell soil colour chart, the colour of the surface ranges from reddish yellow to reddish brown (5YR 6/6, reddish yellow; 5YR 5/6, yellowish red; 5YR 5/4, reddish brown), and is usually burnished or polished. The paint associated with reddish/reddish brown sherds is typically darkish purple, quite close to the paint of group 2 but darker (5YR 3/3, dark reddish brown; 5YR 3/1, very dark grey; 10R 2.5/1, reddish black). There are some examples with reddish paint (10R 4/4, weak red): K09.963 (Pl. 25: 2; Fig. 17: 369) is a sample of sherd without slip, whereas K08.566 (Pl. 25: 2; Fig. 19: 399) seems intermediate between groups 2 and 3.

Painted patterns are usually very basic, restricted to more or less regular, horizontal or vertical bands, short strokes, large (K09.963, Fig. 17: 369; Pl. 25: 2) or thick (K09.1250, Pl. 25: 2) criss-cross marking. When the pattern is more complex, the painting technique is generally coarse. A simple, large reticulated pattern of lines decorates the upper section of neckless jars (K09.963, Pl. 25: 2, Fig. 17: 369). Medium thick painted bands mark the mouth profile and the junction between neck and shoulder of medium size jars (Fig. 19: 424), or of large mouthed jars (K08.566, Pl. 25: 2, Fig. 19: 399), while straight lines divide small handles, both vertically and horizontally (K09.833, Pl. 25: 2). Bands of thick, parallel lines or short strokes are found on the upper profile of the rim of thickened rim bowls (K09.1073, type 2A.23, Pl. 25: 2), sometimes alternated with solid rectangles (Fig. 8: 186) as in group 2. The same bands of short strokes, inscribed within two horizontal parallel lines that run perpendicularly, decorate the upper profile of the rim in shape types ZA (Fig. 27: 522), together with horizontal bands located on the neck. The sherd no. 526 (Fig. 28: 526), pertaining to the shape type ZA has been attributed to group 3 on the basis of surface colours but, if compared to the other samples of group 3, it has a more complex profile, and the painting appears to be more carefully applied. Together with the motif of painted short strokes on outer side rim profiles, common in group 3, a thin, wavy line is located on the rim upper side, inscribed within two parallel, horizontal lines. As in group 2, a large concentric arc of circles may be located on the inner/upper surface of the rim of bowls with S profile (Fig. 10: 217). Small

circles with solid nucleus are found, though very faint, under the rim of bowl K09.1214 (Pl. 25: 2, Fig. 8: 190, type 2A.22c). More complex designs are rarely found and these include cross-hatched triangles (or, more probably, obliquely crossed lines forming hatched rhombs) filled with *quadrillé* between parallel lines (K09.1250, Pl. 25: 2) or other variants of X motifs (Pl. 25: 3).

A very peculiar example is also assigned to group 3 (Fig. 34: 621), showing an articulated combination of motifs: a reticulate band is disposed horizontally between parallel stripes, whereas a short wavy line along one of the horizontal lines frames the upper section of a narrative motif.

The fabrics are not perfectly homogeneous, suggesting the group may include different ceramic productions. On the whole the matrix is gritty with variable frequency of medium-large mineral inclusions. Fabrics with high frequency of inclusions are recurrent. Prevailing inclusions are white, clear white or grey, although a medium to low frequency of samples with reddish brown inclusions is also attested. A relatively large sample of sherds pertaining to group 3 can be attributed to fabric type 10.5: the quality of inclusions is the same, but here with a lower average frequency (see Pl. 25: 2, K09.1250, K09.833, K09.36). Other samples are closer to fabric type 10.6 (Pl. 25: 2, K08.566). K09.1088, originally sorted into group 3, should perhaps be considered separately since it has a very distinctive fabric, close to fabric type 17. Very fine fabrics, with few mineral inclusions, are sparse (Pl. 25: 2, K09.812). The colour of the fracture is usually reddish, but slightly bicolour or sandwich fractures are quite frequent, suggesting somewhat inaccurate firing.

On the basis of varied painted patterns and fabrics, the group of painted wares with reddish surface might include different productions. The main cluster, however, relates to a slightly coarse/fast manufacture within the common ware production.

Connections are visible with the decorative patterns of group 1 and 2, whereas the reddish surface colour recalls that of group 7.

References:

Pl. 25: 2; Pl. 25: 3

Fig. 8: 186 (K08.523, type 2A.22a), 190 (K09.1214, type 2A.22c); Fig. 10: 217 (K12.1853, type 2A.30); Fig. 17: 369 (K09.963, type 5A.2); Fig. 19: 399 (K08.566, type 6A.1a), 424 (K12.860, type 6B.6); Fig. 27: 522 (K12.1342, type ZA.8); Fig. 28: 526 (K08.548, type ZA.10); Fig. 34: 621 (K12.1704)

Group 4

Group 4 includes polychromic painted sherds (Pl. 24: 1). They are characterized by the presence of blackish and reddish paint patterns, not particularly accurate, over a yellowish/whitish slip. The group includes different variants of production.

Some samples have completely mat finishing (Pl. 24: 1, K10.45, K10.27): the surface is well smoothed, but not burnished. The paint, red (10R3/4, dusky red) and black (10YR 3/1, very dark grey), is very thin and weak, its state of preservation extremely poor. Painted motifs are substantially geometric, but K10.45 might include a naturalistic component. Despite the use of two colours, the lines of the picture are largely irregular in the trait, suggesting quite a fast decorative process. The paint is located over an almost whitish slip (10YR 8/2, very pale brown).

K09.81 and K09.336 represent a slightly different variant. They have a yellowish slip, with traces of burnishing. The paint consists of the typical blackish colour (7.5YR 4/1, dark grey), similar to that of group 1, and reddish-brown colour (2.5YR 6/4, light reddish brown). If compared to the previous types, the paint is slightly thicker and better preserved. The red paint, however, is more watery than the darkish one. The lines are irregular. The reddish paint is mainly used for solid coverings, whereas the blackish shade is used both for outlines and for solid coverings. The same use of the two colours, with the blackish as main colour and the reddish as secondary, is found in group 10. Solid coverings are not particularly accurate: traces of the red paint, evidently applied only after the darkish one, are frequently visible over the edges.

Other samples are attested with more lustrous finish and a slightly different range of colours (see K10.27 and K08.362b). The slip is mainly yellowish (10YR 8/3, very pale brown), thick, and painted motifs are weak red/purple (10R 3/4, dusky red) and black (2.5Y 2.5/1, black). Traces of polishing are preserved on the surface. This is not very carefully applied, but this impression might be the consequence of a bad state of preservation. Remarkably, both the slip and the paint have the same glossy appearance, suggesting that polishing was done after the paint had been applied. The relatively small size of the recovered sherds prevents us from delineating any more precisely the true nature of the painted motifs, but they would seem to be mainly geometric. In the case of the sherd K10.27, the section preserved should correspond to the edge of a bicolour frame, enclosing a panel in the whitish slip;

in K08.362b a section of a more complex pattern is preserved, including a large, horizontal, blackish band and a geometric sketch in red colour and blackish dots.

K08.585 represents a variation of the production described above. The sample have a thick buff slip (7.5Yr 8/2, pinkish white) over which a black (7.5YR 2.5/1, black) and a red paint (10R 4/6, red) have been applied. As with the previous group of sherds, both the paint and the slip have a glossy appearance, suggesting that the polishing was carried out after painting. The paint, although the red is more watery than the darkish shade, is generally thicker than in the previous groups. Once more, traces of red over the black indicate the red was applied after the black.

The surface finish of no. 558 (Fig. 30: 558, Pl. 24: 1) is similar to that of the painted wares of group 1. It presents a thick, whitish-yellow slip (2.5Y 8/3, pale yellow), evenly burnished. Red (2.5YR 4/4, reddish brown) and darkish brown lines (7.5YR 3/2, dark brown), not particularly well preserved, highlight the shape.

In the sherd K09.1186 (Pl. 24: 1), in addition to the reddish and the black paint over the whitish-yellow slip, a further chromatic element is attested, given by a strong brown burnishing preserved over a small section of the fragment. It is not clear whether it is a proper slip or the effect of burnishing over the bare surface. Interestingly, the black and the white sectors have a dull appearance, whereas the reddish ones, together with the brownish, have a glossy appearance.

Fabrics are mainly gritty, mineral, with medium texture and density. The sorting is largely fair or poor. A medium-high frequency of white and clear white inclusions is recorded, of both small and medium-large size. Reddish brown inclusions are sporadic. An exception is represented by K09.1186, which presents a medium-fine sandy fabric, with fine texture. The fractures are usually reddish, but slightly darker cores are also attested.

All of the samples recovered that could pertain to this group consist of body sherds or minor components, so information regarding shapes is lacking. Most of the sherds, however, seem to relate to closed vessels.

On the basis of different surface finishing and thickening and colorimetric variations of the paint, the group seems to include different productions among a shared tradition of polychromic paintings. Together with the use of two coloured paint in association with a whitish-yellowish slip (which could be considered time-consuming in terms of common ware production), they also appear to share a less than careful execution of the decorative elements.

The use of two main colours, the darker shade being the main colour and the reddish tone the lesser, is common also to group 10.

References:

Pl. 24: 1

Fig. 30: 558 (K09.899, type W); Fig. 34: 626 (K09.81)

Group 5

Within group n. 5 of painted wares, examples with a characteristic thick and glossy or lustrous slip have been grouped, characterized by decorations in a reddish brown colour over a buff base. The examples that can be assigned to this group are few and all consist of body sherds, so no precise information about shapes can be gleaned. The recovered sherds can, however, be related to closed shapes, and K09.9 pertains to a necked jar.

Main surface colours are the whitish-yellow (10YR 8/3, very pale brown) and a deep dark-reddish brown (2.5YR 3/4, dark-reddish brown) (see especially K09.677, K09.9, K09.976). Other shades of brown are sometimes recorded in addition to the main colours, but it is not always clear whether they are to be considered as slips, self-slips or paints. The patterns are mainly geometric, whereas the application of the paint denote a medium-high accuracy.

In K09.9, a whitish-yellow panel inscribed in a large dark-reddish brown frame holds the main painted motif of the preserved section. Within the panel, another motif in dark-reddish brown paint is inserted. Two thin, wavy lines crossing each other shape a series of elongated 'almond like' forms, alternately covered in paint and reserved. The panel covers most of the surface of the sherd, but in a small section further bands and lines in reddish brown colour (5YR 4/4, reddish brown) are visible over a light brown base (5YR 5/6, yellowish red). As far as we can judge at x5 magnification, the light brown base and the whitish-yellow colour constitute two different coatings directly applied to the surface in different sections of the pot. The dark-reddish brown and the reddish-brown colours were then applied on top of these. The glossy finish covers the entire surface, indicating that this was applied after the painting.

In K10.113 the colour of the panel is slightly different from the white-yellowish section of the other examples, being almost white. As in K09.9, however, the main surface colour seems to be light brown.

The thick whitish slip (10YR 8/3, very pale brown), the neat paint traits and the gritty fabric of K12.1131 (Pl. 23: 5; Fig. 29: 552) suggest an association with this ceramic group, but the surface finish is slightly less lustrous than in the other sherds. The colour of the paint is also slightly different (5YR 3/3, dark reddish brown).

K12.1131 (Pl. 23: 5; Fig. 29: 552) has a thick whitish slip and a brown paint. The finish is homogeneously glossy, but less lustrous than the other examples.

Among fabrics, both gritty (K09.677, fabric type 10.6) and fine fabrics (K09.9) are attested. All of them have mineral inclusions, medium and medium-large or small. The nature of the inclusions varies from white, clear white, and grey. Reddish-brown inclusions are sporadic.

The fractures are mainly reddish in medium thickness examples. Sherd K09.9, instead, which has a fine and medium-high density fabric, presents a greyish core, indicating incomplete oxidation.

The small group of painted wares with thick and glossy paint is quite homogenous in terms of surface finish and painted patterns, whilst the fabrics are less so. The surface treatment is quite accurate and the fabrics, firing technology and wall thickness essentially point to a common ceramic production.

References:

Pl. 23: 4; Pl. 23: 5; Pl. 24: 3, K09.677, K09.09, K10.113, K09.976

Fig. 29: 552 (K12.1131, type 9); Fig. 33: 605 (K12.2200, type H12)

Group 6

Group n. 6 includes different variants of painted sherds characterized by accurate surface finish and painted patterns of bands and lines (Pl. 24: 5-6).

A very fine group of sherds with polychrome paint has been isolated on the basis of distinctive recurring elements such as polished brownish surface and the presence, among reddish and greyish painted bands, of a characteristic white band. This might correspond to the so-called 'Galatian Ware' (Pl. 24: 6).

Sherds pertaining to this group have a very fine fabric, with fine texture, high density and good sorting. Visible inclusions are rare, mainly white and very small (fabrics are usually 9 or 16). The fractures appear quite well oxidized, from light red (2.5YR 6/8) to a reddish yellow colour (5YR 6/8). The surface treatment is very accurate: surfaces appear well polished, with a slightly lustrous appearance. The colour of the surface, apparently un-slipped, is mainly brownish (5YR 5/6, reddish yellow). The distinctive traits are the polychrome painted bands in white, red, and greyish colours. The paint is usually very thin, almost transparent in some cases⁶⁵. The red and the greyish bands may be very narrow (1-2 mm) and neat, while the white ones are wider. Different arrangements are registered: red and greyish bands may be present in the same piece in an alternation of narrower and slightly wider bands, closely juxtaposed or alternated with a reserved band in a brownish colour or with a wide white band. White bands are always found between two bands of other colours.

Most of the recovered fragments consist of body-sherds, mainly pertaining to very open shapes (apparently plates or bowls), with painted decorations located on the inner side (see as example Pl. 24: 6, K12.1133, K12.773 and K12.317). In other cases, the painted decoration is located on the outer side (see Pl. 24: 6, K12.496 and K12.218; Pl. 24: 5, K09.76). A single rim-sherd is attested that pertains to the same category (Pl. 24: 6, K12.218), and is part of a curved bowl with upper convex sides (type 2B.5b). In this case, the red band is wide and continues onto the lip and the outer upper section of the wall. The disc base sherd K09.51 (Pl. 21: 4) is probably also to be attributed to the same pottery production⁶⁶.

The sherd K12.1133 is slightly thicker and has a slightly coarser fabric (fabric type 9.1) compared to the other examples, but the surface treatment and the typology of the painted bands are the same.

Although the white band is not preserved, K09.589 (Pl. 26: 6; Pl. 30) should also probably be attributed to the same group: the inner side surface and the fracture are greyish, probably as a consequence of an alteration in firing atmosphere. The fabric is quite fine, but various inclusions are visible and the fracture is smooth (see fabric 16.1). Together with K12.773, they are distinguished from the others by the very thin and precise bands (1mm *ca*) and the incompletely oxidised fabric⁶⁷. Other fine

⁶⁵ In terms of the Munsell soil colour chart, the red band mainly appears 2.5YR 4/6, red, or 2.5YR 4/4, reddish brown; the darkish one appears mainly 7.5YR 5/3, brown, or 7.5YR 5/1, grey.

⁶⁶ See § 2.2.3., *Grey Ware [G] [Gp] [Gr]*.

⁶⁷ In both cases, small voids with darkish contour are visible on the freshly broken sections, suggesting the presence of incompletely burned carbonates.

ware sherds with neat and thin painted bands in red colour (without greyish and white bands) (Pl. 24: 6, K12.1137) present the same fine fabric as the 'Galatian' group, suggesting a close connection. Other sherds with greyish and red bands consistent with the typical painted pattern and fabric of the 'Galatian' group, but lacking the white band, probably pertain to the same class (Pl. 24: 6, K12.1343). The absence of the white band might be due to the state of preservation. Where white bands are preserved, in fact, they are usually almost transparent, suggesting that the paint is less durable than that used to the red and greyish bands.

Different variants of painted band sherds with a similar brown polished surface are attested that seem to be quite close to the group described here but, on principle, we decided not to attribute any sherds without the typical white band to this category. The surface is polished, with slightly lustrous appearance, brownish in colour. The painted bands are quite neat, monochrome, red or reddish brown in colour (Pl. 24: 5, K10.203, K09.312, K10.155, K09.654, K09.639, K10.40, K09.76). The fabric of the sherds, however, is completely different, being markedly richer in mineral inclusions of different qualities. The fabric of the sherd K12.267 (Pl. 24: 6) which, given the bichrome red and greyish bands, seems extremely close to the group of 'Galatian' ware (two greyish bands alternated with a red one and two reserved ones), corresponds to this second group.

References:

Pl. 24: 5-6

Group 7

A small sample of sherds have been placed in group 7, characterized by blackish paint on whitish slip over the reddish surface of the vessel (Pl. 24: 2).

The typology and the colours of both the blackish paint (5YR 2.5/1, black) and the whitish slip (10YR 8/3, very pale brown) are similar to those of group 1. As in some variants of group 1, traces of burnishing are attested on the whitish slip, but the paint is above it, thus giving a dull finish. The painted traits are generally accurate. Painted patterns include geometric motifs, chiefly composed of bands of parallel, oblique traits disposed between two horizontal lines. This specific theme occurs over horizontal, thickened bands (K09.702), according to a fashion already known from other groups of painted wares (see K10.224, Pl. 23: 6, Fig. 34: 612; K08.2164, Pl. 25: 2). According to the state of preservation of the recovered sherds, the vessel surface is not slipped, but bears traits of polishing/burnishing, producing a sort of glossy appearance. The colour of both matrix and surface is red (5YR 5/6, yellowish red; 2.5YR, 5/8, red).

Fabrics are mainly gritty, mineral. The texture varies from medium-fine (K09.702) to medium, with medium or medium-high density and fair sorting. The quantity of inclusions is medium. They consist of white and clear white small grits (fabric type 10.5) or small darkish grey inclusions.

The fractures are fairly homogeneously reddish, attesting to a fair-good control of firing processes.

Most of the recovered samples pertain to body sherds or to other minor components of the vessels but they mainly indicate closed shapes.

Overall, despite some variations in fabrics, the group of painted sherds just described seems to reflect a homogeneous production, but closely related to other groups already observed. It bears close similarities to the deep buff slip sherds of group 1, with which it shares the colour and typology of both the slip and the paint, and with group 3, with which it shares roughly the main surface colour and the absence of a definite slip.

References:

Pl. 24: 2

Group 8

Within group 8 are a series of examples with brownish paint characterized by the use of both reddish and whitish slip (Pl. 24: 7).

A distinctive pattern has been isolated in the use of three main colours: white, red and brown. The brown, or reddish brown, is always the colour of the painted motifs. It is not always clear, instead, whether the white and red shades are slip or actual paint.

In K09.1246 (Pl. 24: 7, Fig. 28: 531, type ZA.10), most of the preserved surface bears a buff slip (10YR 8/3, very pale brown), quite thick and evenly burnished. The buff slip is replaced by a red slip (2.5YR 5/6, red) in the lower section of the inner side surface. Simple, geometric painted motifs, consisting of a single line running along the upper pointed profile of the lip and a short stroke on the outer side of the rim profile, are found over the buff slip, unburnished.

In other examples the main slip is light brown (7.5YR 6/4, light brown) (see K09.158, K09.181), and it is replaced by a red slip (2.5YR 5/6, red) on the inner and outer side of the rim. On the neck of K09.158 (Pl. 24: 8, Fig. 27: 525, type ZA.9), a red colour is also applied over the light brown slip, in a fashion that, as far as we can tell from the preserved section, is quite similar to that of a paint.

Major decorative patterns are represented by reddish brown painted motifs (5YR 4/3, reddish brown) over a white panel (10YR 8/3, very pale brown) (K09.181, Pl. 24: 8, Fig. 27: 523, type ZA.8).

Among recurring motifs, series of concentric circles are frequent. If compared to similar figures found in other groups, it is worth noting that the concentric circles found here are larger, and inserted in a white panel. The decoration of K08.549 (Pl. 24: 7, Fig. 34: 624), seems to be related to a similar pattern, and is characterized by markedly accurate lines.

The fabrics are mainly gritty, with medium texture. The density varies from medium to medium-high. Prevailing inclusions are white and clear white, of medium size. Among recurring fabrics, type 10 is quite frequent, as is a slightly finer variant of fabric type 10.5, characterized by the presence of inclusions of the same quality but in a lower frequency.

The fractures are mainly reddish, suggesting a good degree of control of firing processes, but completely greyish cores are also attested (K09.181).

The range of shapes includes primarily shape types ZA.8 and ZA.9.

Despite some variation in fabrics, the group seems to reflect a rather homogeneous production that is, however, closely related to other isolated groups. Close similarities with group 2 are found from the morphological point of view, whereas painted patterns and colours find connections with groups 1, 2, 3 and 7.

References:

Pl. 24: 8; Pl. 24: 7, K09.158; K09.1246, K08.549

Fig. 27: 523 (K09.181, type ZA.8), 525 (K09.158, type ZA.9); Fig. 28: 531 (K09.1246, type ZA.10); Fig. 34: 624 (K08.549).

Group 9

Within group 9, different painted samples have been included, characterized by brownish/grey surfaces, evenly burnished (Pl. 25: 4).

Some samples are clearly not slipped (K09.1054, K09.116, K09.107), while in other cases a very thin slip seems to be present. The surface appearance is largely glossy. For this reason it is not always easy to identify the manufacturing technique, but some of the samples seem to be at least partially hand-made (see K09.692).

The colour of the surfaces varies from greyish (10YR 6/2, light brownish grey; K09.116), to greyish-buff (10YR 6/2, light brownish grey; K09.107) and brown (7.5YR 4/3, brown; K09.692).

The paint is mainly dark brown (7.5YR 3/2, dark brown; 5YR 3/2, dark reddish brown), usually showing a glossy finish that suggests burnishing took place after the painting. The patterns are largely geometric and simple, including horizontal lines and bands, thick frame circles, short strokes, single crossed lines (K09.961, K09.116) and criss-cross rhombs (K09.961). Large parallel bands are located on the outer and inner upper side of bowls (K09.967, Pl. 25: 4, Fig. 8: 184, type 2A.22a), together with small parallel short strokes on the upper rim profile (K09.107, Pl. 25: 4, Fig. 8: 187, type 2A.22b). Irregular bands may be located at the junction between neck and shoulder in medium size jars (K09.692, Pl. 25: 4, Fig. 20: 458, type 6C.9). In shape type ZA, wavy bands are located on the inner/upper side of the stepped rim marking the step, possibly the support for a lid. At the same time, thin parallel and perpendicular lines appear on the neck section of the vertical and the horizontal parts of the upper section of the vessel (K09.324, Pl. 25: 4, Fig. 27: 513, type ZA.8). With the exception of a few examples (K09.324, Fig. 27: 513, type ZA.8), the nature of the painted traits is mainly coarse, suggesting rapid decoration.

Fabrics are mainly gritty, including different variants of type 10 fabrics, such as 10.4, 10.3 and 10.6. Other more sandy fabrics are also attested, like fabric type 7 (K09.692). The texture is usually medium or medium-coarse, with medium density and fair/poor sorting.

The colour of the matrix is highly variable, ranging from brown/reddish brown (mainly 7.5YR 4/3, brown; see K09.692, K09.1100, K09.1054), to light yellowish brown (10YR 6/4, light yellowish brown; K09.116, K09.107), light brown (7.5YR 6/6, reddish yellow; K09.961) and reddish (10R 6/6, light red; K09.967). Completely grey matrix is also attested (2.5Y 6/1, grey; K09.324).

The fractures frequently show traces of non-homogeneous firing. Both in open and closed shapes, the inner-side margins are usually darker in colour than the outer, indicating a different level of oxidation.

Shapes includes bowls with thickened rim, shape type ZA and, though only sporadically, jars with short neck.

Overall the group appears slightly heterogeneous. It probably includes different productions, but all of the sherds share aspects of coarseness (in firing, shaping, or painting) suggesting a somewhat fast production process. Clear elements of continuity, visible both in morphological and in decorative patterns, are attested with groups 1, 2 and 3.

References:

Pl. 25: 4

Fig. 8: 184 (K09.967, type 2A.22a), 187 (K09.107, type 2A.22b); Fig. 20: 458 (K09.692, type 6C.9); Fig. 27: 513 (K09.324, type ZA.8); Fig. 34: 618 (K12.923)

Group 10

Within the group 10, we have placed polychrome painted sherds characterized by the use of brownish and reddish-brown paint over a buff base. It constitutes a close variant of group 4, from which it is distinguished by the specific range of colours, the accuracy of the traits and the thickness of the paint (Pl. 24: 4, Pl. 24: 3, K09.958).

The vessels have a thick buff slip (10YR 8/3, very pale brown; 2.5Y 8/3, pale yellow). Traces of burnishing are sometimes attested (K12.494), while in other cases the surface appears mainly well smoothed (K12.177). K12.178 instead has an unusual vitrified surface.

The painted decoration was evidently applied after the burnish, the paints having, in fact, a generally dull appearance.

The main colour of the paint is darkish brown (7.5YR 3/2, dark brown), which is used for both outlines and coverings. The reddish brown colour (5YR 4/4, reddish brown) is used for coverings and for minor filling in motifs. As for most examples in group 4, the red was applied after the main colour. The lines are firm and quite thin, but generally not particularly precise.

Painted patterns are rather dense and exclusively geometric. These include: horizontal series of rhombs, alternatively covered with red paint or filled in with a dense darkish brown criss-cross pattern; horizontal and vertical stripes, marking the main sections of the design; and short wavy lines, and chessboard motifs (K12.594), with rhombs alternatively covered in red or darkish brown. K12.177 shows a peculiar 'fabric like' motif, with a reticulate of quadrangles filled in with alternating vertical (darkish brown) and horizontal (red) lines that recall a warp and weft pattern. Unusually, in K09.598 (Pl. 24: 3, Fig. 33: 609, type H15), the red colour has also been used for the main outline. The pattern, consisting of a geometric sketch of zigzag lines between stripes filled in with small dots, also appears to have been quite accurately produced.

As far as fabrics are concerned, fabric type 10.5 (K09.598) is sporadic, while fabric types like 10.1 and 10.6 are more common. Overall, texture is medium, with medium density and average medium frequency of inclusions. Most common inclusions are white grits of medium-medium/large size. Clear white inclusions and grey grits are, however, also frequent.

The fractures are generally a homogeneous reddish colour, attesting almost complete oxidization.

Since most of the samples recovered pertain to body sherds, we have no clear evidence regarding the precise morphological range, but large vessels, possibly large mouthed jars or shape types ZA, are likely.

Overall, despite some discrepancy between fabrics, the group 10 indicate a homogeneous production, close in continuity with others groups of painted wares. The use of primary yellowish slip and blackish paint inserts is in the same tradition as group 1. The use of two main colours for the painting is shared with group 4, as are some of the general decorative motifs.

The ceramic production attested with group 10 is mainly to be considered within the horizon of common ware. The painted decoration is not particularly accurate, but the nature of the painted patterns, which include the use of two colours, thin and thick lines, suggests a relatively time-consuming activity.

References:

Pl. 24: 3, K09.598; Pl. 24: 4

Fig. 33: 609 (K09.598, type H15); Fig. 34: 622, 623, 625 (K12.177, K12.178, K12.494)

Sporadic painted samples

A few sherds have been recovered that do not fit the general groupings described above. Among others, K08.2199 (Pl. 25: 3, Fig. 34: 617), presents an unusual pattern, composed of alternated bands of (probable) painted triangles and triangles covered with lines parallel to the sides. K09.800 (Pl. 25: 6) has a thick slip with glossy finish: the painted motif, consisting of two irregular wavy lines within

painted bands, is not attested elsewhere in the surface repertoire of Uşaklı Höyük, but the range of colours and surface finish are not very different from other painted sherds collected within the group 9.

K09.919 (Fig. 8: 178) presents irregular darkish horizontal lines it appears possible to interpret as paint. However, no other sherd of the same type has been found on the surface.

Moreover, a few sporadic painted sherds have been found in grey ware [Gp].

Remarks

The painted wares just described represent a large part of the Uşaklı Höyük surface inventory. Clearly, different painted productions are attested, but there are significant elements of continuity to be noted in the painted motifs, which recur in different combinations.

Naturalistic or descriptive themes are sporadic, but one example may be K08.1908 (Fig. 34: 615)⁶⁸. The sherd has a brownish slip and the surface is not perfectly smoothed but it is unusually highly vitrified. The paint, of reddish-brown colour, is dull and applied over the vitrified surface. The marks have clearly been rendered quickly, the thickness of the colour continuously varying. The design might represent a tree, but the preserved section is too small for us to be certain of this⁶⁹. Similar motifs are found on K10.45 (Pl. 24: 1, group 4), but inscribed within a geometric frame.

The painted patterns of the Uşaklı Höyük surface inventory generally do have, instead, high decorative value. A marked connection can be observed between paint and morphology, with specific painted motifs recurring in association with specific morphological sections of the vessel, highlighting their volumetric components. The designs are essentially geometric.

Simple lines and bands are most frequent, found alone or as the foundation for more complex designs. Horizontal bands are found on the necks or under the rims, while bands of radial short strokes are found over the upper profile of thickened rims. A band consisting of two horizontal lines filled in with oblique short strokes is frequently found on relief bands (K10.124, K08.990, Pl. 23: 6; K09.702, Pl. 24: 2; K08.2164, Pl. 25: 2).

Wavy lines are found over or under the rims, or vertically, joining groups of straight lines. Small concentric circles are found in groups 1-3, while they are large (and very large in some cases) in group 8.

A recurring motif (especially in group 1) is that of series of triangles with an elongated cathetus on the neck of shape type ZA (K09.727, Pl. 23: 1; K09.621, Pl. 23: 6; maybe K09.309, Pl. 23: 6).

Many designs are built on crossing bands and lines that create rhomboidal shapes and frames, which become the base for criss-cross, reticulates, chessboard motifs or more complex designs (see Pl. 25: 5). Simple X motifs are found on flattened handles or on the short neck of jars (K08.990, Pl. 23: 6; K12.39, Pl. 25: 3; K09.116, K09.961⁷⁰, Pl. 25: 4).

Criss-cross pattern is found usually in monochrome blackish paint as filling in motifs of rhombs (Pl. 24: 4; K09.1001, Pl. 25: 1; K09.1250, K09.812⁷¹, Pl. 25: 2) and, more rarely, bands (Fig. 34: 621).

Reticulates or chessboard motifs are frequently built on crossed lines, and developed alternating red, black and yellowish-reserved coverings (K09.81, K09.336, Pl. 24: 1; Pl. 24: 4). The same pattern is used for the filling of alternating, oblique bands (K12.494, Pl. 24: 4).

On the basis of the surface finish and the painted pattern, groups with monochrome paint 1-3, 7 and 9 seem to be considered close variants within a shared painted tradition. Similarities are also, however, clearly visible with the polychrome group 10 and with some variants of group 4, suggesting a form of continuity. Groups 5 and 6, distinguished on the basis of the particularly accurate surface finish and painted patterns, differ rather more.

Surface colours vary from yellowish (whitish yellow, or buff), light brown to reddish brown. Often there is a coat: most of the sherds with yellowish surface are slipped, whereas the light brown or red-

⁶⁸ This sherd represents one of a number of cases where attribution to one of the other main groups failed. The colour of the slip is close to that most common in group 2, but the unusual vitrified finish does not find any parallel. The fabric, instead, is slightly closer to that of the sherds in group 1.

⁶⁹ On the basis of the thickness/weakness of the paint, the 'branches' on the right side of the 'trunk', seem to have been painted from the lowermost (if our orientation of the fragment is correct) to the uppermost in groups of three, the painted line going from the left (that is, from the 'trunk') to the right side. This can be seen in two complete sets of 'branches' each consisting of three lines, the lowest having the thickest paint and the uppermost the faintest, with the deepness of the colour gradually decreasing as well. Assigning a value of 3 to the thickest painted branches, of 2 to the medium branches and 1 to the faintest, the sequence observed on the preserved sherd is, from bottom to top, as follows: 2, 1 – 3, 2, 1 – 3. The same sequence is not observed on the left side.

⁷⁰ Not visible in the picture, the paint is located on the side not shown.

⁷¹ Not visible in the picture, the paint is located on the side not shown.

dish brown surfaces may also be bare. Polishing/Burnishing finish are quite frequent. With the exceptions of groups 4 and 6, where it is fairly accurate, the quality, intensity and location of the polish/burnish vary greatly. In the case of the partially slipped vessels, the paint is always applied over the slip and, remarkably, after the surface finish, keeping a dull appearance. The majority of the examples are monochrome, the main colour of the paint being blackish (different shades of darkish brown), while a brownish purple variant is also frequent and red is more rarely found. Polychromes are less frequent but well attested. In polychrome sherds the main colour is also blackish, used for both outlines and coverings. The second colour, mainly used for minor filling in motifs and for coverings, is red or a shade of red. Frequently, the two colours are applied over a yellowish/white base, which constitutes a third colour either in the form of a slip or, apparently more rarely, of paint. Further chromatic variations are sometimes created by variations of the reddish/reddish-brown slip.

A large percentage of recovered painted examples are body sherds: the majority belong to closed shapes although we cannot be more precise as to which shapes exactly. The range of attested morphologies is not very wide. Among recurrent shapes, small bowls with rounded sides, curved bowls with thickened rim, type ZA shapes and some varieties of short necked jars are attested. Pots without neck are sporadically found.

There is a medium high variability in fabric types, but overall they are largely gritty, with prevailing white and clear white grits. Grey grits are also well attested, while reddish brown grits are sparse. Average quality of the painted production is medium: the vast majority of recovered sherds have medium thick walls, with medium texture and density, and fair sorting. Finer examples are attested, but generally, it appears that the painted wares are to be ascribed to the common production.

2.2.3.₁₁ *Pink Slip Ware [Ps]*

The pink slip ware is a minor wheelmade variant distinguished by the presence of a pink slip that cannot be better related to other clusters. However sporadic, the group is quite heterogeneous, suggesting that the samples collected might pertain to different ceramic traditions. Overall, they belong to the common ware ceramic horizon. The colour of the slip is generally 7.5YR 7/4 or 5YR 7/4 (pink), applied in the form of a thin layer with almost irregular covering. Surfaces may be simply smoothed or burnished. Clay colours in section are usually reddish or brownish, with a rather homogenous core. Both sandy and gritty fabrics are attested, with medium or medium-high frequency of mineral inclusions. No specific recurrence of fabric has, however, been recorded. Attested shapes include curved bowls (shape type 2A.11c or 2A.26, Fig. 9: 203), high necked jars (Fig. 20: 432) and large mouthed vessels (Fig. 26: 506; Fig. 27: 524).

References

Pl. 18: 5, K08.2049 (type 2A.11c); Pl. 21: 7, K09.958; Pl.22: 6, K09.985
 Fig. 9: 203 (K12.1956, type 2A.26); Fig. 20: 432 (K09.958, type 6C.2); Fig 23: 476 (09.985, type 8B.1);
 Fig. 26: 506 (K08.920, type ZA.5); Fig. 27: 524 (K08.2204, type ZA.9)

2.2.3.₁₂ *Plain Ware [P]*

All of the samples the specific features of which did not come within the range of variable associated with more specific clusters have been catalogued under the label of plain ware, which constitutes the largest section of the ceramic inventory⁷². A small number of plain ware examples are handmade, and have been analysed in the section of handmade pottery, while the vast majority were wheelmade.

The group is rather heterogeneous in terms of both technological properties and function. The quality of the samples, in fact, ranges from fine to coarse, and the functional horizon includes fine, common, and storage ware contexts. Moreover, the high variability of fabrics and shapes clearly indicates that the plain ware production is common to different ceramic horizons.

The samples collected are distinguished by the absence of any specific surface finish other than a simple smoothing. Smoothing quality ranges from low to quite accurate. Traces of burnishing may be sporadically found, but these are almost always limited to small sections of the vessels⁷³. Unsmoothed

⁷² For exposed examples, see the Ware 'P' in the Catalogue of Plates (pgs. 201-208), and in the Catalogue of Figures (pgs. 209-290).

⁷³ Sporadic traces of burnishing are mainly located on the lips of the vessels.

samples are also well attested, which are rough or harsh to the touch. Although self-slip is frequently attested, the vessels are substantially bare.

Surface and matrix colours include principally reddish and brownish nuances, but yellowish samples are also found. The sections are frequently slightly darker than the surface, but completely greyish cores are not particularly frequent, indicating relatively accurate firing techniques. Wall thickness varies from thin to medium-thick.

A marked variability is registered in fabrics. Sandy or small grit fabrics, with an abundance of small, white and grey mineral inclusions or sands particles (K09.239, K09.662, K09.447, Pl. 31) are quite frequent, similar to drab and red slip ware fabrics. More or less dense gritty fabrics are also quite widespread, characterized by a high frequency of different varieties of small and medium size mineral inclusions, like white, clear white, grey and, especially, red inclusions (K09.66, Pl. 31), which are common to more probable 1st millennium painted and yellow slip traditions, and to some coarse grained productions. Some very fine examples have been found that are characterized by a very fine and dense fabric, almost depurated and with a well-smoothed surface, which are more likely to be connected with late productions (K09.1024, Pl. 31).

The range of shapes is quite wide, including both open and closed vessels, usually of medium/medium-large size. Carinated bowls with vertical upper sides and marked carination (see types 2B.16-18) have been mainly assigned to this category, but fabrics and surfaces are frequently very close to that of drab ware⁷⁴.

2.2.3.₁₃ *Pseudo-Brittle Ware [Br]*

Gritty fabric, bare, rough surface, very thin walls, hard and fragile appearance, characterize a group of sherds clustered under the label of pseudo-brittle ware. The name has been chosen on the basis of similarities with the Northern Syria and Iraq plain ware production dating from the 2nd to 7th century AD and already known in archaeological literature as Brittle Ware.

The pseudo-brittle ware is wheelmade, reddish or brownish in colour. Surfaces are bare, un-porous and vitrified. They are left rough, almost abrasive to the fingers, the irregularities given by the gritty fabric. Usually they are a reddish-brown colour (2.5YR 5/4, reddish brown), sometimes (see K09.226, Pl. 22: 4, Fig. 19: 419), a greyish surface (7.5YR 6/2, pinkish grey), the difference between the greyish surface and the reddish clay matrix possibly being caused by the firing atmosphere or depositional conditions.

Matrixes are reddish or brownish. Even though the walls are very thin, around 3.5mm, the fractures may have a sandwich appearance, with reddish brown margins (5YR 5/4, reddish brown) and darkish core (10YR 4/1, dark grey) (Fig. 19: 413, K09.855), indicators of changing firing conditions or incomplete firing. An incomplete burning of carbonaceous matter, however, may be connected with the high matrix density of some of the vessels (Rice 1987: 334). In other cases, the fractures are homogeneously red (2.5YR 6/8, light red). The fabrics are gritty, with frequent mineral inclusions. The texture is medium or medium-fine, with medium-high or even high density. The sorting, instead, is poor, characterized by a fine clayish matrix with inclusions from small to medium and large size, in medium-high/high quantity. The principle visible inclusions consist of different variants of medium-large size grits of angular or rounded shape, whitish, grey and white coloured. Flattened, brown grits are also attested. White small inclusions, rounded or shaped like flakes, are usually present in medium, medium-high frequency.

The range of shapes of the pseudo-brittle ware is quite restricted and standardized, limited to small jars with short neck, convex or everted, with unbroken profile (shape type 6B.2, 6B.3, 6B.4). A handle may be attached on the rim.

Overall the group is quite homogeneous, suggesting a specific ceramic production. There are, however, similarities with the group of coarse grained ware, which presents roughly the same surface treatment but has thicker walls. As far as we can judge from the small sample recovered, the manufacture is standardized and the process rapid, suggesting a rather large scale of production. As far as colours, surface treatments and, to a certain extent, fabrics are concerned, close similarities with the kitchen ware can be noted. The pseudo-brittle ware however has essentially thinner walls and denser texture. Despite the parallels with a kitchen ware horizon, the recovered sherds did not present evident traces of use on the fire, so that an interpretation within a more general common ware horizon is likely.

⁷⁴ See footnote 47.

References:

Pl. 22: 4, K09.226

Fig. 19: 412 (K12.1910, type 6B.2), 413 (K09.855, type 6B.3), 415 (K09.943, type 6B.3), 419 (K09.226, type 6B.4)

2.2.3.¹⁴ *Red Slip Ware [Rs]*

The group of sherds with a red slip represents a large part of the Uşaklı Höyük ceramic inventory. A minority are handmade examples, which have been analysed together with the other handmade types⁷⁵. The vast majority, instead, are wheelmade samples.

Wheelmade red slip wares are well attested in Central Anatolia in the 2nd and 1st millennium BC, and the Uşaklı Höyük inventory clearly includes samples from different ceramic traditions. Marked variability is recorded in fabrics and surface finish. The range of shapes, despite large differences in minor typological variants, is wide but relatively standardized.

The nature of the slip ranges from a thin layer of clayish covering, more similar to a self slip than to real slip, to rather thick layers.

Since it usually covers only a section of the vessel, we have encountered some difficulty distinguishing between red slip sherds and possible sherds with simple red painted bands, especially in the case of body sherds. In the closed shapes, the slip is usually located on the outer surface and onto the upper part of the inner surface. As far as open shapes are concerned (most of which are different variants of bowls with convex upper sides or carinated bowls), the slip is generally concentrated on the outer side, which may be covered in total or only on the upper section. On the inner side, the slip covers the upper or only the very upper part of the sides (see, for example, Fig. 4: 76; Fig. 7: 148; Fig. 8: 168)⁷⁶. Many examples are also found with complete slip both inside and outside (see Fig. 3: 46; Fig. 7: 161)⁷⁷. In other cases, the slip is limited to the sole area of the mouth (Fig. 10: 229). This is especially frequent in small and medium-small bowls, as in carinated bowls with short, vertical or inturned upper side (Fig. 10: 238-239; Fig. 11: 247, 249, 252). The same is true for the inside pointed rim bowls (Fig. 3: 68; Fig. 4: 71, 73). In these cases, the slip is usually very thin, red or reddish brown in colour, and burnished. The rest of vessel, instead, is bare, untreated or simply smoothed. Bowls slipped only on the outer side are also well attested (see, for example, Fig. 10: 232-233)⁷⁸. Closed shapes (see, for example, Fig. 16: 345-351)⁷⁹ and large vessels (Fig. 21: 461, 463; Fig. 22: 465, 473; Fig. 23: 481-482) are normally slipped on the outer side, with the slip sometimes continuing onto the very uppermost part of the inner surface.

Both mat and lustrous surfaces are attested. A more or less shiny finish is frequently used on the section covered by the slip, while unslipped areas are more frequently mat. Burnishing is quite frequent, while more accurate polishing is rarer: traces of flattening instruments, in fact, are usually evident. Typically, it is uneven and irregularly applied. When the burnish is found only near the mouths of bowls with slip, it is mainly horizontal whereas it can have varying orientation when extended to more of the surface. It rarely covers the entire surface of a vessel.

This marked variability in the quality of the surface finish finds a precise comparison in the typical Hittite red slip ware production. Higher quality examples are reported for *karum* and early periods of the Hittite sequence, while both the quality and quantity of red slip ware decrease towards the late period, when the production is mainly of medium to low standard (Schoop 2011b, 243).

The colour is usually one of the red variants of hue 10R on the Munsell soil colour chart (10R 5/6, 5/8, 4/6 or 4/8), of which 10R 5/6 (red) is the most frequent lighter variant and 10R 4/6 (red), which is rarer, a slightly darker variant. More brownish shades are, however, also attested (5YR 5/6, yellowish red).

⁷⁵ See § 2.2.3.^{17,3} *Handmade Red Slip Ware [Rs-Hm]*.

⁷⁶ See in the specificity Fig. 4: 76; Fig. 7: 148, 155, 157, 159; Fig. 8: 168; Fig. 9: 205; Fig. 10: 240, 244; Fig. 11: 246, 248, 253, 256-258, 260-261, 263-265, 267-268, 271-272; Fig. 12: 277-278, 292-294, 296, 299, 304-305; Fig. 13: 318-321; Fig. 15: 340-343.

⁷⁷ It is to be borne in mind that the vast majority of our examples do not have a complete profile. See, specifically, Fig. 3: 46, 48-49, 65-66; Fig. 5: 113; Fig. 7: 161; Fig. 8: 166, 183, 191; Fig. 9: 199, 201; Fig. 10: 224-225, 228, 235, 242, 245; Fig. 12: 281, 284, 289-290, 297-298, 301-302; Fig. 29: 557.

⁷⁸ See, specifically Fig. 10: 232-233, 241, 243; Fig. 11: 254, 259, 262, 269; Fig. 12: 303; Fig. 13: 313; Fig. 15: 336.

⁷⁹ See, specifically Fig. 16: 345-351, 353-354, 357; Fig. 17: 573, 380; Fig. 18: 388-389, 395, 397; Fig. 19: 403, 405; Fig. 20: 433, 446-447, 449, 453, 457, 459.

The fabrics are mainly between reddish and brownish shades (2.5YR 5/6, red; 2.5YR 5/4, reddish brown; 5YR 5/6, 5/8 or 4/6, yellowish red). Sections with darkish cores are quite frequent, indicating incomplete firing. The typical recurrence of such cores also in thin walled examples could be due to a combination of factors, such as high carbonate content on the fabric, fineness of the texture and low firing⁸⁰. Homogeneously reddish sections, indicating that carbonaceous particles have been completely burned out, are more frequently observed in thick-walled examples, like the red slip storage ware sherds. With the exception of the fact that firing was 'complete' for storage ware vessels and 'incomplete' for fine and common ware vessels, we have too little evidence to be able to draw any wider conclusions from this observation. It is, however, possible that both the red slip fine and common ware vessels, characterized by relatively fine and dense fabric, and the storage ware vessels, characterized by relatively coarser fabric, were fired in approximately the same way (perhaps even together?). This would explain the carbonates having been burned out completely in the thicker and coarser examples but only partially in the finer and denser ones.

There is marked variability in the fabrics (see Pl. 29, K08.1750, K09.43, K08.1747, K08.1638, K08.237, K09.276, K08.2030). Most commonly, fabrics are sandy, with medium-small and small mineral inclusions, medium-fine or medium texture and density. Prevailing inclusions are sand particles and white particles. Micaceous particles and grey inclusions are also frequent. Fabric types 0, 1, 2, 2.1, 3, 4, 5, 5.1, 6, 6.1, 7, 8, 9.1 and 13 are common. Fine and very fine examples are of fabric type 9 and 16. Grit and large grit fabrics are also attested, like fabric type 10; 10.1, which is shared also by the brown burnished ware; 11; 10.5, which is shared also by the painted ware. Fabric type 12 is common to both some red slip ware sherds and coarse grained ware, which is most probably a 'late production'.

Fabric type 12.1 is typical of a particular group of storage jars, which are characterized by the use of two different slips, red and buff/brown (7.5YR 7/4, pink, or 7.5YR 6/4, light brown). The main examples include (see Pl. 17: 7) K08.1026 (Fig. 24: 484), K08.1113 (Fig. 24: 485), K09.1216, K08.957 and K08.1027. The red slip is located on the outer surface, on the rim and on the very upper section of the inner side. A buff or yellowish slip, instead, shapes a large band under the rim on the outer side, where the red slip is reserved, and continues on the upper section of the inner side. In some cases (see for example K08.1026), the buff slip is very thin, looking more like a sort of self-slip than a real coat, while it is thick and well polished in others.

The same kind of surface finish finds a parallel in some wide mouthed vessels with outside thickened rim and ridge on the shoulder (Pl. 16: 3, K08.2105, K08.1224; Fig. 18: 387-388).

The range of shapes in red slip ware is quite wide⁸¹. Carinated bowls constitute the most frequent morphologies, corresponding to 34% of the red slip ware inventory (Diagram 3), followed by simple bowls (16,7%). Also quite frequent are shape type ZA, representing 8.3% of the inventory; short or medium size neck jars (6.7%) and storage jars (4.6%). The most frequent morphologies (Diagram 3) include medium size carinated bowls with upper convex sides and simple or outside thickened rim (Types 2B.3, 2B.4a-b and Types 2B.7a-c, 2B.8), of which the smaller variants are also quite frequent (Types 2B.5a-b). Other significant morphologies include carinated bowls with vertical upper sides (Types 2B.2a-b); simple bowls with convex upper sides or inside pointed rim (Types 2A.3-4, 2A.14a-c); simple bowls with everted upper sides and inside bevelled rim (Types 2A.18e, 2A.19a-b, 2A.27) and small carinated bowls with everted upper sides (Type 2B.1)⁸². As far as the specific morphological types are concerned, a fairly extensive series of minor variants is attested by sporadic samples, while the most significant morphologies include the shape types 2B.7a, 2B.2b, 2B.7c, 2B.5b and 2B.4a⁸³. Eight examples with stamp impressions have been also found.

Although common ware examples prevail, the red slip ware covers both the fine, the common and the storage ware ceramic horizon. As far as the Hittite ceramic tradition is concerned, red slip vessels are sometimes considered together with the standard drab ware production, of which they are simply considered a coated variant (Schoop 2011b, 243). In the Uşaklı Höyük ceramic inventory similarities

⁸⁰ Due to the pore spaces within which particles and gases can move, in oxidizing atmosphere carbonates burn out at a relatively low temperature in coarse wares, while the same process requires higher/longer firing in finer wares. See § 2.2.1.3, *Technology*.

⁸¹ See Diagram 4 for the complete range of morphological types and variants attested in red slip ware. See Diagram 2 and 3 for larger groupings.

⁸² See Diagram 3 for main morphological groups attested in red slip ware.

⁸³ See Diagram 4. It is worth noting that some shapes with high incidence are largely generic, like the types 6, W and 2.

can, in fact, be seen between some of the red slip ware fabrics and the finer fabrics of the drab ware. More evident in our analysis, however, is the frequency, common to both ceramic classes, of darkish cores, mainly related to the composition of the paste – that is, clay sources and tempering materials – and firing technologies, which might be indices of shared technological behaviours⁸⁴.

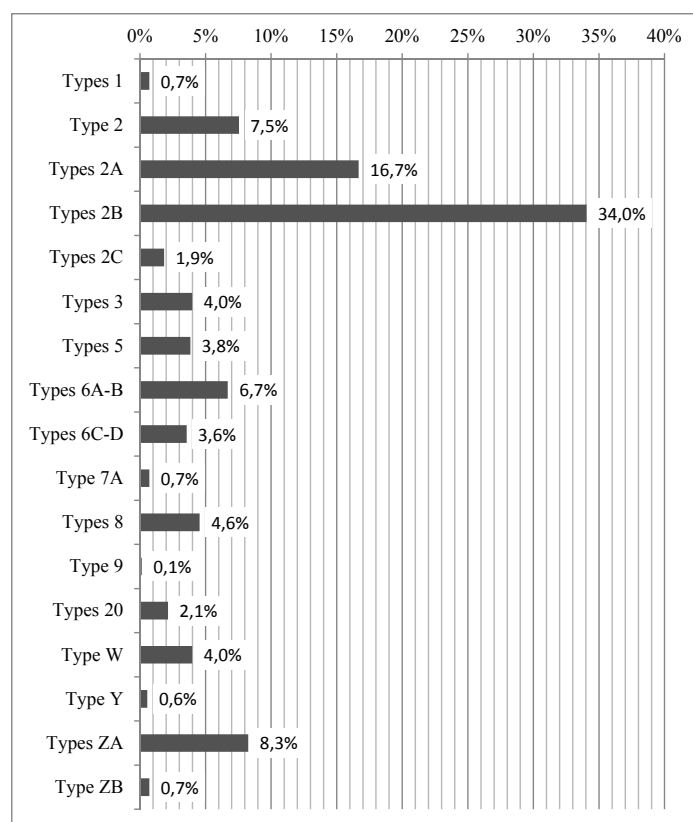


Diagram 2: The range of general morphological categories attested in red slip ware⁸⁵.

| | |
|------------|---|
| Types 1 | Plates |
| Type 2 | Bowls-generic |
| Types 2A | Simple bowls |
| Types 2B | Carinated bowls |
| Types 2C | Deep bowls |
| Types 3 | Small jars |
| Types 5 | Large mouthed vessels |
| Types 6A-B | Medium and short necked jars |
| Types 6C-D | High necked jars |
| Type 7A | Large, open vessels |
| Types 8 | Storage jars |
| Type 9 | Lids |
| Types 20 | Spouts |
| Type W | Undetermined shapes |
| Type Y | Undeterminable large mouthed vessels |
| Types ZA | High necked, large mouthed vessels (kraters and jars) |
| Type ZB | High necked small vessels |

⁸⁴ See § 2.2.1., *Technology*.

⁸⁵ Percentages are calculated for a total number of 702 red slip ware diagnostic sherds with identified morphology.

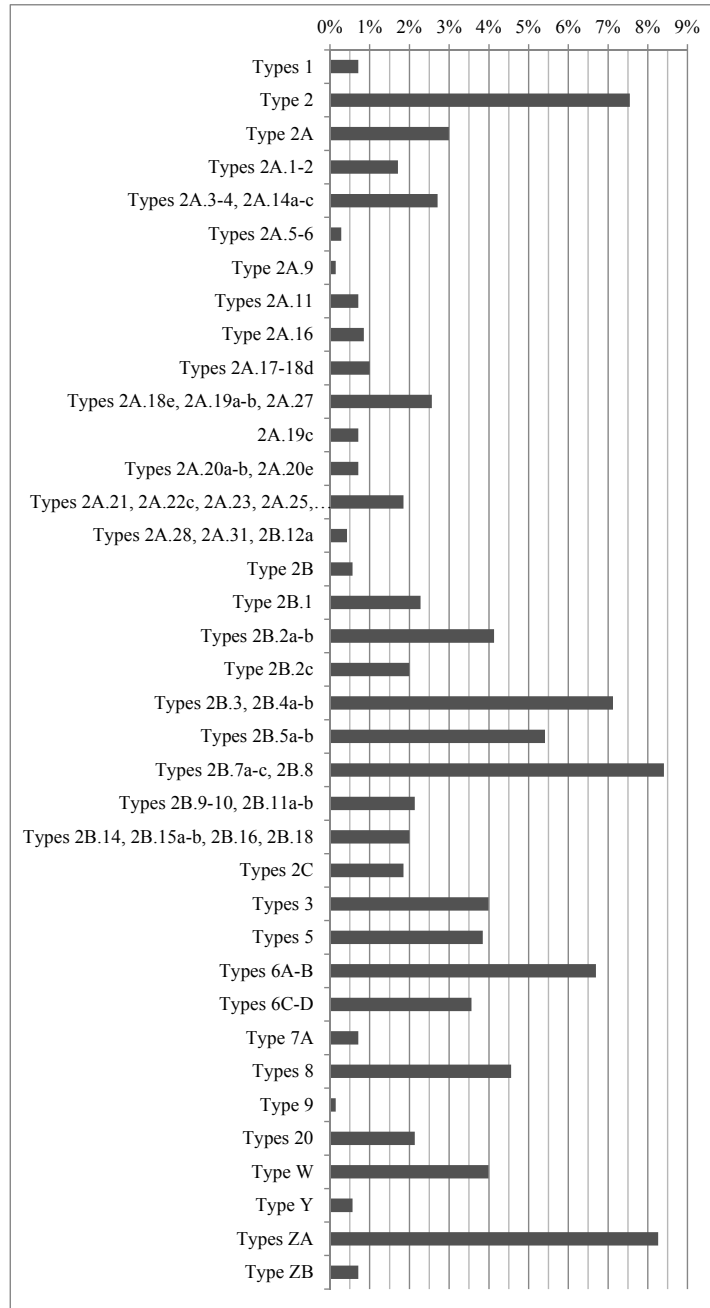


Diagram 3: Main morphological groups attested in red slip ware.

| | |
|---|---|
| Types 1 | Plates |
| Type 2 | Bowls: generic |
| Type 2A | Simple bowls: generic |
| Types 2A.1-2 | Simple bowls with curved sides |
| Types 2A.3-4, 2A.14a-c | Simple bowls with convex upper sides or inside pointed rim |
| Types 2A.5-6 | Simple bowls with straight sides |
| Type 2A.9 | Simple bowls with thick wall and inside thickened, flattened, bevelled rim |
| Types 2A.11 | Simple bowls with outside thickened, tapered rim |
| Type 2A.16 | Vertical upper side, rounded rim/simple bowls with curved sides and thick walls |
| Types 2A.17-18d | Simple bowls with inturned rim |
| Types 2A.18e, 2A.19a-b, 2A.27 | Simple bowls with everted upper sides and inside bevelled rim |
| Type 2A.19c | Simple bowls with everted upper sides and inside bevelled, thickened rim |
| Types 2A.20a-b, 2A.20e | Simple bowls with inside thickened rim |
| Types 2A.21, 2A.22c, 2A.23, 2A.25, 2A.29b | Medium size simple bowls with curved sides and thickened rim |
| Types 2A.28, 2A.31, 2B.12a | Simple bowls, various |
| Type 2B | Carinated bowls: generic |
| Type 2B.1 | Small carinated bowls with everted upper sides |
| Types 2B.2a-b | Carinated bowls with vertical upper sides |
| Type 2B.2c | Small carinated bowls with inturned upper sides |
| Types 2B.3, 2B.4a-b | Carinated bowls with upper convex sides |
| Types 2B.5a-b | Small carinated bowls with upper convex sides |
| Types 2B.7a-c, 2B.8 | Carinated bowls with upper convex sides and outside thickened rim |
| Types 2B.9-10, 2B.11a-b | Small carinated bowls with inturned upper sides and thickened rim |
| Types 2B.14, 2B.15a-b, 2B.16, 2B.18 | Carinated bowls with flaring upper sides |
| Types 2C | Deep bowls |
| Types 3 | Small jars |
| Types 5 | Large mouthed pots |
| Types 6A-B | Medium and short necked jars |
| Types 6C-D | High necked jars |
| Type 7A | Large, open vessels |
| Types 8 | Storage jars |
| Type 9 | Lids |
| Types 20 | Spouts |
| Type W | Undetermined shapes |
| Type Y | Undeterminable large mouthed vessels |
| Types ZA | High necked, large mouthed vessels (kraters and jars) |
| Type ZB | High necked small vessels |

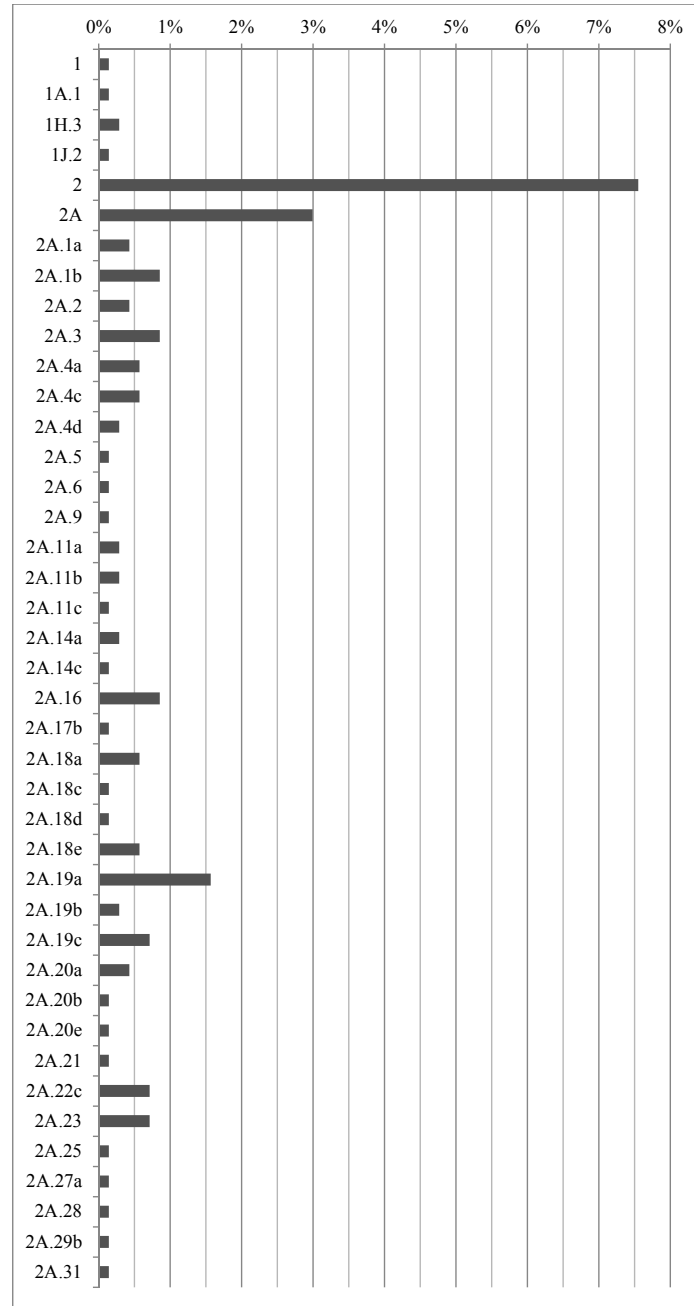


Diagram 4a: The complete range of types attested in red slip ware (types 1-2A).

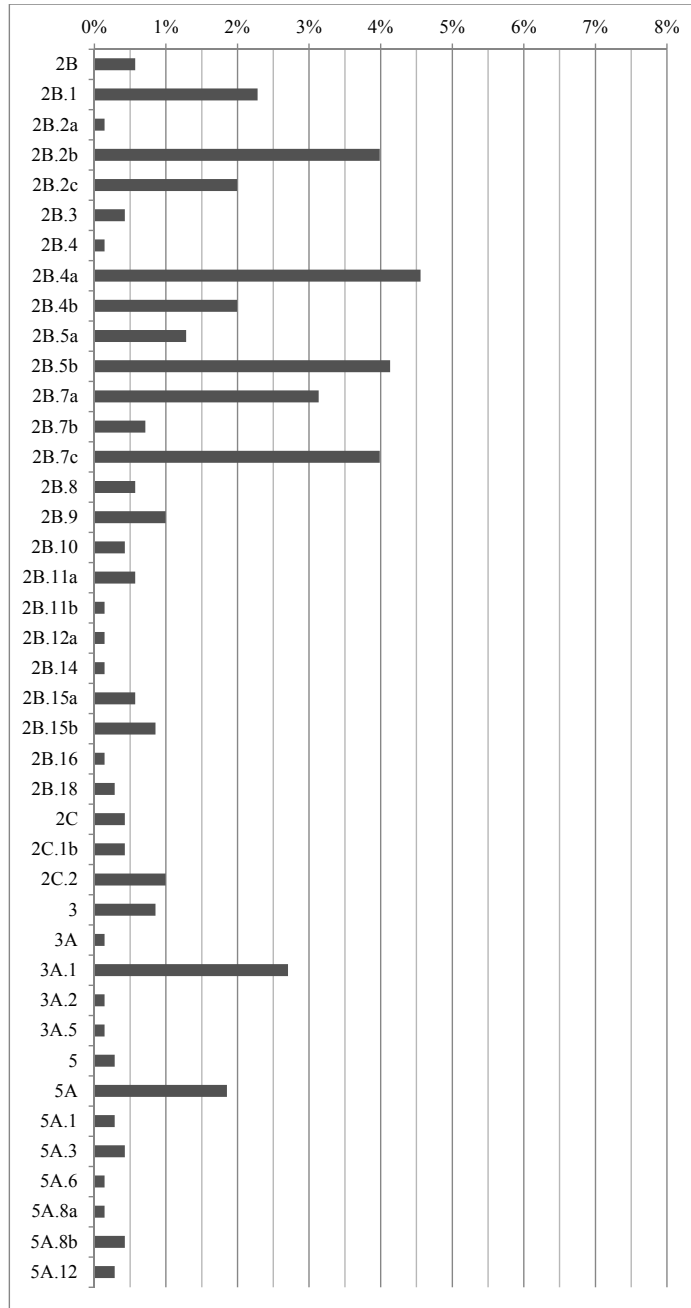


Diagram 4b: The complete range of types attested in red slip ware (types 2B-5).

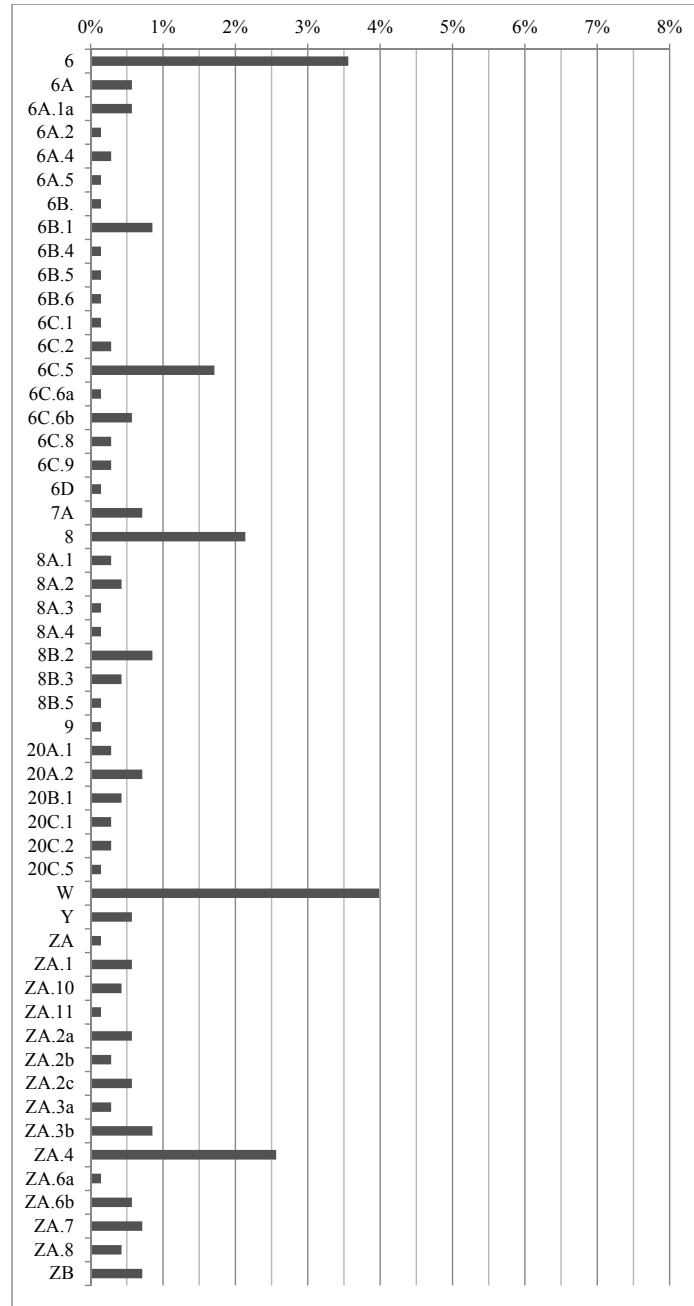


Diagram 4c: The complete range of types attested in red slip ware (types 6-Z).

References

Pl. 16; Pl. 17: 1; Pl. 17: 2, K08.1087, K08.878, K08.375, K08.1252, K08.368, K08.2123, K08.1020, K08.2013; Pl. 17: 3-7; Pl. 20: 1-2; Pl. 20: 4, K08.191; Pl. 27: 8; Pl. 28, K08.2137, K08.2109, K08.534, K08.1558, K08.760, K08.1020, K08.1039; Pl. 29, K08.1750, K09.43, K08.1747, K08.1638, K08.237, K09.276, K08.2030

Fig. 2: 36 (K12.506, type 1J.2); Fig. 3: 46 (K09.884, type 2A.1b), 48-49 (K12.4, K12.2111, type 2A.2); 65-67 (K12.5, K12.664, K09.1273, type 2A.3), 68 (K08.1687, type 2A.4a); Fig. 4: 71, 73, 76 (K08.1498, K09.870, K08.792, type 2A.4); 85 (K08.1344, type 2A.9); Fig. 5: 113 (K12.211, type 2A.14c); Fig. 6: 119-120 (K12.327, K12.1480, type 2A.16); Fig. 7: 148, 155-156 (K09.90, K08.86, K12.37, type 2A.18), 157, 159, 161 (K08.2137, K12.2113, K12.1768, type 2A.19); Fig. 8: 166, 168 (K12.989, K12.655, 2A.19), 183 (K12.110, type 2A.21), 191 (K12.337, K2A.22c); Fig. 9: 199 (K12.667, type 2A.23), 201 (K12.532, type 2A.25), 205 (K12.425, type 2A.27a); Fig. 10: 215 (K12.51, type 2A.29b), 222 (K12.357, type 2A.31), 224, 226, 228-229, 232-233 (K08.2206, K08.435, K12.104, K12.780, K12.505, K09.1145, K08.435, type 2B.1), 235 (K08.1220, type 2B.2a), 238-244 (K12.2115, K12.222, K08.1097, K08.1390, K08.857, K12.44, K12.223 type 2B.2b); Fig.

11: 245-246 (K08.470, K08.1356, type 2B.2b), 247-250 (K12.973, K12.947, K08.1558, K12.789, type 2B.2c), 252-254 (K08.1452, K12.1868, K09.623, type 2B.3), 256-265 (K08.574, K08.1327, K12.786, K08.799, K12.1764, K08.1821, K09.314, K12.793, K12.1555, K12.34 type 2B.4a), 266-272 (K08.1392, K08.1566, K12.1089, K09.913, K08.2109, K08.261, type 2B.4b); Fig. 12: 277-278 (K12.82, K10.23, type 2B.5a), 281, 282, 284 (K12.1184, K08.425, K12.654, type 2B.5b), 282 (K08.425, type 2B.5b), 289-296 (K09.98, K12.659, K12.229, K12.519, K12.430, K12.351, K12.1288, K12.2122, type 2B.7), 297-299 (K08.773, K09.659, K08.2133, type 2B.8), 301-302 (K09.1, K12.1771, type 2B.9), 303 (K09.886, type 2B.10), 304-305 (K09.1274, K08.368, type 2B.11); Fig. 13: 313 (K12.53, type 2B.14), 317-321 (K08.293, K08.1039, K10.167, K08.700, K09.704, type 2B.15b); Fig. 15: 336 (K12.432, type 2C.1b), 340-343 (K08.1289, K09.2, K10.218, K08.1626, type 2C.2); Fig. 16: 345-351, 353-354 (K12.1708, K08.1236, K09.887, K12.520, K12.431, K12.232, K08.1254, K12.660, K12.1777, type 3A.1), 357 (K08.2026, type 3A.2), 359 (K08.822, type ZB), 363 (K12.356, type 3A.5); Fig. 17: 365 (K08.1931, type 5A.1), 373 (K08.1905, type 5A.3), 380 (K08.1234, type 5A.6); Fig. 18: 387-389 (K08.2105, K08.1224, K08.413, type 5A.8b), 397 (K12.55, type 5A.12); Fig. 19: 403 (K12.237, type 6A.4), 405 (K08.750, type 6A.5); Fig. 20: 433 (K08.941, type 6C.2), 446-447, 449 (K08.929, K08.1467, K12.444, type 6C.6), 453 (K12.753, type 6C.8), 457 (K12.521, type 6C.9), 459 (K09.1277, type 6D); Fig. 21: 461, 463 (K08.972, K08.868, type 7A); Fig. 22: 465 (K08.544, type 8A.1), 473 (K08.1456, type 8A.3); Fig. 23: 481-482 (K08.427, K08.306, type 8B.1-2); Fig. 24: 484-485 (K08.1026, K08.1113, type 8B.2-3); Fig. 25: 490 (K12.533, type 8B.3); Fig. 26: 492 (K08.1549, type ZA.1), 493-497 (K08.1760, K08.728, K12.1289, K10.179, K08.2030, type ZA.2), 498-501 (K08.1284, K08.777, K08.1638, K08.1323, type ZA.3), 510 (K08.1900, type ZA.6b), 512 (K08.237, type ZA.7); Fig. 28: 532, 534 (K12.1290, K12.1362, type ZA.10), 536 (K08.1111, type ZA.11); Fig. 29: 540-541, 543-545 (K08.291, K09.3, K12.286, K08.1458, K08.1139, type 20.A), 546-547, 551 (K08.424, K08.1163, K09.1279, type 20C), 556-557 (K09.1245, K08.290, type W); Fig. 31: 568, 570, 575, 579 (K08.1574, K08.746, K08.346, K08.952, type B); Fig. 32: 583-585, 590-593, 599 (K08.816, K09.1280, K08.856, K08.1512, K08.741, K12.282, K08.1123, K08.1203, type H); Fig. 33: 602, 604 (K08.547, K08.1753, type H); Fig. 34: 627-634, 638 (K08.1907, K08.1243, K12.484, K12.804, K09.1256, K08.858, K09.8, K08.432, K08.1150).

2.2.3.₁₅ *Reddish Brown Ware [Rb]*

The group of reddish brown ware includes a small cluster of fine ware sherds isolated on the basis of a typical reddish brown slip and of burnished/polished surfaces.

The colour of the slip varies from reddish brown (2.5YR 4/4, reddish brown) to brown (5YR 4/2, dark reddish grey) and dark-brown (5YR 3/1, very dark grey). Probably due to a combination of finishing techniques and firing conditions, alternated thin streaks and lines of red and reddish brown colour are attested (2.5YR 4/4, reddish brown; 2.5YR 5/6, red. See Fig. 10: 230-231). Brown nuances are also found (5YR 4/2, dark reddish grey).

The surface is perfectly smoothed, and well polished-burnished. The fabrics are mainly fine, characterized by fine texture, high density and good sorting. Small white inclusions are usually attested in small frequency, together with sporadic small reddish grey inclusions. Voids from very small to medium-small are also observed in low frequencies. The fractures show homogeneous firing.

The number of diagnostic sherds referable to this class is quite limited, as is the range of shapes. They consist of small plate type 1J.1 (K12.47, Fig. 2: 34, Pl. 26: 6), small bowls with upper-convex sides (type 2B.5a) and small bowls with upper everted sides (Fig. 10: 230-231, type 2B.1). A ring base pertaining to an open shape is also attested (K12.1652, Fig. 31: 573, Pl. 26: 6).

The sample is very limited, but overall homogeneous, suggesting a distinct production within the fine wares horizon. The surface colours in some cases are quite close to those of the brownish variant of the orange slip ware, but the fabrics do not appear to be as fine. Morphological similarities can also be seen with the finest cluster of red slip wares (see shape type 2B.1).

References:

Pl. 26: 6, K12.47, K12.1562

Fig. 2: 34; Fig. 10: 230-231

2.2.3.₁₆ *Yellow Slip Ware [Ys]*

The group of yellow slip ware includes quite a wide variety of samples that are characterized by the presence of a slip of yellowish colour. The collection is not entirely homogeneous: the bulk of recovered yellow slip potsherds presents a rather thick slip with burnishing or polishing finish, but a smaller cluster of other generic yellowish coatings is also attested.

The thick slip variant is usually homogeneously distributed over almost the entire surface of the vessel. It is generally located on both outer and inner sides in open shapes, while in closed shapes it mainly covers the outer side, extending onto the uppermost section of the inner side. Finishing techniques mainly include accurate burnishing or light polishing.

Generic yellowish coatings instead, are more frequently simply smoothed, covering either a section or the entire surface of the preserved sherd.

The colour of the yellow slip ranges from whitish yellow (2.5Y 8/2 and 8/3, pale yellow) or deep yellow (2.5Y 7/4, pale yellow), to more reddish hues, like the 'deep buff slip' (10YR 7/3 or 7/4, very pale brown), typical of wheelmade painted ware of group 1, or reddish yellow (7.5YR 7/6, reddish yellow). The colour of the clayish matrix is usually brownish or reddish (5YR 6/6, reddish yellow; 5YR 6/4, light reddish brown) and is mainly homogeneous.

A marked variability is registered in fabrics, since both sandy and gritty variants are attested (Pl. 30: K09.1233, K09.297, K09.281, K09.357, K08.569, K09.277). Inclusions, however, are always of mineral origin. Very fine samples with depurated fabric and fine texture (K09.1233, Pl. 30) are a minority, while different varieties of gritty fabrics are more frequent and are similar, in many cases, to some of most common wheelmade painted variants (Pl. 30). Major visible inclusions include white and clear white angular grits, sand particles and grey angular grits. Fabric types with reddish grits are also attested (fabric type 17, Pl. 30, K09.297).

The range of shapes includes small fine ware bowls with pointed rim (Fig. 3: 53, type 2A.2) or with convex upper sides (Fig. 12: 279, 283, type 2B.5b); medium thick bowls with curved sides (Fig. 6: 128, type 2A.17a); inside thickened rim bowls (Fig. 9: 207) and deep and large bowls with thickened, squared rim (Fig. 15: 338-339, type 2C.1a).

The inventory of thickened rim bowls is extensive (Fig. 8: 165, 170, type 2A.19; Fig. 13: 307, type 2B.12a), among which bowls with outstretched rim are particularly distinctive (Fig. 10: 213, 215, type 2A.29b) and medium (Fig. 22: 466, 472) and large storage jars (Fig. 23: 479). Handles are also quite frequent.

The inventory of necked vessels comprises high necked jars with folded rim (Fig. 20: 435, 439, 441, type 6C); very small jars (Fig. 16: 360, type ZB); sporadic short necked jars (Fig. 19: 426, type 6B.6) and probable kraters (Fig. 27: 517, type ZA.8).

Yellow slip potsherds belong mainly to the fine and common ware ceramic horizon, but storage ware samples are also attested.

This collection most probably includes examples from different ceramic traditions. White slip wares, to which some of the samples within our yellow slip ware inventory may be associated, are commonly reported in central Anatolia in the 2nd and 1st millennium BC. Appearing mainly towards the end of Early Bronze Age, the white slip ware continues and essentially increases throughout most of the 2nd millennium in Hittite contexts where, as is the case also for the red slip ware, it is considered an integrated part of the Hittite drab ware production (Schoop 2011b: 243). The cluster of Uşaklı Höyük yellow slip ware may include both 2nd and 1st millennium BC specimens. Gritty fabrics, especially with reddish inclusions, are more likely to be related with the 1st millennium ceramic horizon, since they are quite close to fabric types already recorded in many 1st millennium painted sherds. More difficult instead is the interpretation of finer samples with sandy or depurated fabric, which might correspond either to the cream or white slip wares registered in Hittites contexts or to later productions.

References

Pl. 22: 5, K09.4; Pl. 23: 7, K09.774 (type H1), K09.780 (type H7), K09.253 (type H1), K09.427 (type H8), K09.747, K09.718, K09.797; Pl. 26: 2, K08.569; Pl. 26: 6, K08.762; Pl. 30, K09.1233, K09.297, K09.281 (type H8), K09.357 (type 6B.1), K8.569

Fig. 3: 53 (K09.1233, type 2A.2); Fig. 6: 128 (K10.145, type 2A.17a); Fig. 8: 165 (K12.826, type 2A.19c), 170 (K12.214, type 2A.19d); Fig. 9: 207 (K12.45, type 2A.27b); Fig. 10: 213-215 (K12.343, K12.51, type 2A.29b); Fig. 12: 279, 283 (K12.220, K12.219, type 2B.5b); Fig. 13: 307 (K12.428, type 2B.12a); Fig. 15: 338-339 (K12.562, K12.233, type 2C.1a), 344 (K12.557, type 5A); Fig. 16: 360 (K08.569, type ZB); Fig. 19: 426 (K12.19, type 6B.6); Fig. 20: 435 (K12.253, type 6C.2), 439, 441 (K12.252, K12.865, type 6C.3); Fig. 22: 466 (K12.869, type 8A.1), 472 (K09.797, type 8A.3); Fig. 23: 479 (K09.4, type 8B.1); Fig. 27: 517 (K12.140, type ZA.8); Fig. 30: 560 (K08.797, type W); Fig. 31: 580 (K09.718, type B7); Fig. 34: 639 (K08.762)

2.2.3.17 Handmade wares

The inventory of the handmade pottery includes examples in plain, red slip and painted wares. The vast majority of these are red slip specimens, while plain ware samples are sparsely attested. It is not

always easy to distinguish between these two categories, as the slip may be quite thin and, in some cases, is more probably a self-slip. In these cases, the range of shapes did not prove to be of help in making more precise distinctions.

2.2.3.^{17,1} *Handmade Painted Ware [Pt-Hm] [C]*

Two main sets of handmade painted samples have been identified: the first includes sherds with simple horizontal painted bands⁸⁶, and the second, sherds with more complex geometric patterns, more probably related to the horizon of so-called 'Cappadocian Ware'⁸⁷.

The first group essentially includes rim-sherds probably pertaining to small or medium size jars with everted neck and simple, rounded rim (Pl. 15: 1, K12.1268). The paint consists of a darkish band located on the lip and on the outer and inner rim profile.

A prevalence of body sherds, instead, is included in the second group. It is, in fact, possible that, at least in a few cases, the two group constitute a single cluster. Most of the body sherds pertain to closed shapes but a few open shapes are also attested (see K09.54, K09.55, K10.156).

The fabrics are not particularly homogeneous. Three main groupings have been observed, distinguished on the basis of prevailing inclusions: a first group with prevailing vegetal inclusions; a second with prevailing mineral inclusions and a third one intermediate⁸⁸. The overall frequency of inclusions varies approximately in accordance with the thickness of the wall, which also varies greatly, from small (K08.539, 3.5-5mm) to very thick (K08.382, 14mm).

No significant recurrence of shapes, patterns and fabrics has been observed.

Among the vegetal tempered group, most of the samples shows prevailing medium large and large chaff inclusions together with different variants of small and medium-small mineral inclusions. These may include small white and grey inclusions; medium size white, whitish, clear white or, sporadically, brownish, angular grits and glistening flakes (K08.382, K09.801, K09.1212). A larger variety of sandy grains and lumps of grains are visible on the close-ups of the cross section (Pl. 28, K09.1212, K09.801), such as flattened clay coloured grits, yellowish and reddish lumps. A smaller number of examples have clearly prevalent chaff inclusions of medium-small size and sporadic, small mineral inclusions (K12.1268). Texture is usually medium, with medium density, poor sorting and medium or medium-high frequency of small and medium size visible inclusions.

The fabric of a large group of sherds presents a relatively high number of mineral inclusions together with sparse and small vegetal inclusions. The texture varies from medium (K08.1695), to medium/medium-fine (K10.101, K08.1376) with medium density, and sorting ranging from fair to poor. Visible inclusions vary from medium to medium/high frequency, while their size ranges from small to medium. Of great interest is the presence among these of lumps and particles of a yellow colour. This kind of inclusion might, in fact, derive from the local outcrop of marls⁸⁹. Major visible inclusions are the yellowish or whitish ones, of small size, in low to medium frequency. Other small, sandy particles are sometimes visible, as well as small vegetal inclusions, detectable by the small, elongated voids.

Gritty, mineral fabrics are also quite frequent. Also in this case two main variants have been observed. One presents prevailing white and whitish grits (Pl. 28, K08.1133; K09.55). Other kind of grits are visible on the close up of the cross section, such as very small and small grey and darkish grey. A wider variety of grit inclusions is visible on the other variant (K08.2203, K08.1481) where, together with the white and whitish grains, also medium size clear white grits, deep red and reddish brown grains are attested. Yellowish grains and small vegetal inclusions may also be present.

⁸⁶ These are recorded as ware 'Pt' (Painted), plus building technique 'Hm' (handmade).

⁸⁷ These are recorded as ware 'C' ('Cappadocian' horizon).

⁸⁸ Reference samples for the first group are K08.382, K09.801, K09.1212, K12.1268; reference samples for the intermediate group are K08.1695, K08.539, K10.101, K08.1376, K10.156; reference samples for the second group are K09.1133, K09.55, K08.1481, K08.2203, K09.54 (K09.1133 and K08.1481 not shown).

⁸⁹ This kind of rock (see, as a reference, Pl. 7: 1a) has been also recognized at the base of the archaeological sequence excavated in the area D during season 2015. It easily flakes producing a fine, yellow sand. A similar kind of sand inclusion is particularly evident in K08.539. Smaller rounded yellow sand particles are visible in K10.109, in plain handmade ware. In K08.1376 and K10.101 the particles are too small to be easily detected. The correspondence between the yellow sand observed in the fabric of this group of handmade painted sherds and the rocks of the local virgin soil remains, however, only a hypothesis until further in-depth analyses are conducted.

There is also a great variety attested in firing conditions. Much of the painted handmade inventory has reddish margins and darkish-grey core, suggesting rough firing processes, but rather homogeneously buff fabrics are also attested.

As far as finishing techniques concerns, the surfaces are mainly burnished or polished, showing a light shiny appearance. The accuracy of the finish, however, varies fairly considerably, ranging from rather careless to very accurate (K08.539). Mat surfaces are more rare.

The painted patterns consist of geometric designs of narrower and wider lines, in simple parallel bands, orthogonal or intersecting. The typology varies from thin and very precise lines (K08.539, K09.54) to medium thick, irregular stripes (K09.1212, K10.101, K18.1376). Two main kinds of paint are attested: a very watery variant, almost transparent, light grey (2.5Y 6/1, grey), sometimes perceived as violet or white, and a thicker, almost dark paint (2.5Y 2.5/1, black). Other darkish colours are, however, also attested (10YR 3/1, very dark grey or 10R 4/1, dark reddish grey). A few bichrome examples have also been found (K10.156), with red and black paint.

The surface is most frequently red (2.5YR 5/6, or 10R 5/8, red), generally uncoated⁹⁰. Yellowish bands or sectors, however, are sometimes found (10YR 8/2 or 8/3, very pale brown) which seem closer to slips than to paints, but they are clearly used together with the other painted and burnished patterns for decorative purposes.

The attribution of few small fragments with geometric patterns is difficult. They seem to be handmade, but the small sections of vessel preserved prevent any firm conclusions as to how they were produced. They have roughly polished surface, apparently without slip. The colour of the margins as well as that of the surface is red. The paint is dark, rather thick, mainly glossy in K08.1667 and dull in K10.190⁹¹. The motif is of large zigzag bands and thin lines. Both the pattern and the medium grit fabric find parallels with both the wheelmade and handmade painted wares. The same holds true to a certain extent for K08.1704 (Fig. 34: 619; Pl. 23: 5), although the more complicated and accurate painted pattern would appear to fit better among the wheel thrown painted wares.

Most of the handmade painted sherds recovered pertain to body sherds. Some everted rims of jars have been found with simple painted rim (see above, Pl. 15: 1, K12.1268, Pt-Hm); the geometric painted sherds, instead, pertain both to closed and open shapes and are mainly to be attributed to bowls with convex upper sides.

Overall, the group of painted handmade pottery is to be related to the common ceramic production. Although homogeneous in term of general attributes, there is a relatively high variability in fabrics and decorative patterns.

References

Handmade geometric painted sherds

Pl. 15: 1, K08.1695, K09.1212, K09.801, K08.539, K09.54, K09.55, K08.1133, K08.382, K08.2203, K10.156; Pl. 15: 2, K10.156; Pl. 15: 3, K12.489, K12.492; Pl. 15: 4, K12.617; Pl. 28, K08.1695, K08.1133, K09.801

Fig. 35: 677-682 (K09.1212, K08.1695, K12.1265, K08.2203, K08.1133, K12.1438), 683 (K08.382, type 2B.4a), 684 (K10.156, type 2), 685-686 (K09.801, K12.617)

Handmade painted sherds

Pl. 15: 1, K08.1376, K10.101, K12.1268 (type 6); Pl. 15: 2, K10.101; Pl. 15: 3, K12.1264 (type ZA.4)

2.2.3._{17.2} Plain, Handmade ware [P-Hm]⁹²

The surface of plain handmade sherds is usually burnished, at least in part. They probably relate to different traditions and there is marked variability in the fabrics. The fabric of K09.890 (Fig. 35: 644) is coherent with that of the handmade geometric painted group with prevailing vegetal inclusions, while K10.109 pertains to the intermediate group. K08.1519, instead, is of very rough manufacture, the outer surface being completely irregular. Some traces of burnishing are attested on the inner side surface. The fabric is coarse, gritty and characterized by mineral inclusions. The range

⁹⁰ In many cases, in fact, the surface shows more vivid colours than those of the fractures, suggesting the presence of a light coat. More in depth observation, however, reveals that the different appearance of the surface is more probably the result of polishing/burnishing activity.

⁹¹ Not shown.

⁹² Recorded as ware 'P' (Plain), plus building technique 'Hm' (Handmade).

of inclusions is close to that of handmade geometric painted sherds with mineral inclusions (see K08.1133), but the frequency and the size of the grits is considerably higher. The section is completely darkish, indicating careless firing.

Attested shapes include a complete profile of a plate with straight, low sides (Fig. 35: 642), bowls with curved sides (nos 644, 652), open bowls with straight sides (nos 648-649) and jars with curved-closed neck (no. 668). Typical are some deep shapes, probably bowls, with slightly flexed upper sides (nos 659-661). Other small sherds are more probably to be related to bowls with convex upper sides or to small pots (nos 663-664).

References

Pl. 15: 2, K10.109; Pl. 15: 5, K09.1208, K09.1169, K09.247, K08.1670 (type ZA.4), K09.690 (type 6B.1); Pl. 15: 6, K08.2210; Pl. 15: 8, K12.105 (type 5A); Pl. 15: 9, K08.1519, K08.564; Pl. 15:10, K09.1020, K09.1211
Fig. 34: 641; Fig. 35: 642 (K08.1519, type 1I), 644 (K09.890, type 2A), 648 (K09.1211, type 2A.7), 649 (K09.1169, type 2A.15b), 652 (K10.109, type 2B.5a), 659-661 (K09.1020, K09.1208, K09.247, type 2C.x), 664 (K12.194, type 5A), 668 (K08.280, type 6A), 676 (K08.564, type B1)

2.2.3._{17,3} *Handmade Red Slip Ware [Rs-Hm]*⁹³

The handmade red slip ware is well attested. As far as we can tell from the preserved sherds, the red slip appears to be applied both on the outer and inner surface of open shapes. In correspondence of closed shapes, of which usually only a section of the orifice is preserved, the slip is applied on the outer side and on the upper section of the inner side. In some cases the slip is quite thin, so that sometimes it is not always easy to tell if the sample is effectively coated or simply self-slipped.

Surfaces are frequently coarsely polished/burnished, but simply smoothed surfaces are also attested. Both lustrous and mat surfaces are attested, but small glossy areas, at least, are visible in most of the mat surface samples, suggesting that they may originally have been burnished. Horizontal traces of burnishing are generally shown on the surface of bowls; together with horizontal burnishing, also oblique burnishing may be found in deep or closed shapes.

Light red is the prevailing colour of the slip (2.5YR 6/6, light red, see K08.1237, Pl. 28); darker nuances however are also attested (10R 5/6, red). Clayish matrixes are primarily reddish-orange (5YR 5/6, yellowish red), brown (7.6YR 5/4, strong brown) or red (10R 5/6, red). Moreover, a variety is attested characterized by red slip orifice and brownish walls (Pl. 15: 8, K12.1092, and K12.135).

Firing techniques apparently are quite varied: samples with similar characteristics may, in fact, have either a darkish core or evenly oxidized, reddish fractures. Overall, fabrics vary from medium to coarse, with low to medium density and fair to poor sorting. As far as we can tell from visual analysis with a x5 magnifying lens, the range of fabrics is coherent with that of the handmade painted ware to some extent.

Again, two major variants are attested, one with prevailing vegetal inclusions and the other with prevailing grits inclusions. More similarities are visible with the vegetal and with the intermediate fabrics of the geometric painted ware, while the fabric variant with the grits is different. The fabric with deep red and reddish brown grains is not attested at the moment in handmade red slip ware, whereas as the variant of gritty, mineral fabrics with prevailing white and whitish grits is found.

A limited sample presents a coarse grit fabric with large white and mineral inclusions and chaff (K09.1208). Other inclusions include small white particles and the yellow grains.

It is worth noting that in the vegetal tempered fabric the yellow grains already noted for the geometric painted ware are quite frequent also here (see spec. K08.1237+K08.1238). The fabric of K08.1237 (Pl. 28) is atypical, being slightly finer than the other samples, which present higher average frequency of vegetal inclusions.

The thickness of the wall varies from medium-small to medium-large, but medium/medium-large samples prevail.

The range of shapes is rather limited, in many cases coinciding with that of plain handmade sherds. It includes bowls with curved sides (Fig. 35: 645-647); open bowls with straight sides (nos 650-651); different variants of upper convex sides bowls (nos 653-657) or pots (nos 662, 665-666); jars with curved-closed (no. 667) or everted neck (nos 671-675).

⁹³ Recorded as ware 'Rs' (Red Slip), plus building technique 'Hm' (Handmade).

Among the red slip handmade sherds, two bowls with rounded sides have been found that have thick walls and a relatively large handle (Fig. 6: 121-122). The fabric presents abundant vegetal inclusions of large size. The fracture, as well as the inner surface, are completely darkened, suggesting rough firing.

A high variability is registered from sample to sample and even on the same sherd in the thickness of the slip, as well as in the additional surface treatment (polishing/burnishing). Most common surface finishings however are comparable to those of the painted handmade wares.

The handmade red slip ware is to be connected with the common ware ceramic horizon. Although clearly pertaining to a single ceramic tradition characterized by hand building techniques, a relatively high variety has been observed among surface finish and fabrics. As with the handmade geometric painted ware, variations could be explained in terms of production and/or of chronological differences.

References

Pl. 15: 2, K10.192, K10.46, K10.35 (type 6A); Pl. 15: 4, K12.663, K08.846; Pl. 15: 5, K08.1237/8, K09.790, K09.892, K08.1108 (type 6A), K08.1886 (type 2A.15b), K08.1796; Pl. 15: 7, K12.1140; Pl. 15: 8, K12.107, K12.1092 (type 2B.2b), K12.106 (type 5A), K12.112 (type 5.A), K12.135; Pl. 15: 9, K08.883, K08.1128, K08.2195, K08.1231; Pl. 16: 1, K08.1275; Pl. 28, K08.1237

Fig. 6: 121-122 (K12.2034, K08.1275, type 2A.16); Fig. 11: 266 (K08.1237, type 2B.4b); Fig. 35: 643, 645, 647 (K09.790, 12.661, K12.107, type 2A), 646 (K12.108, type 2A.16), 650-651 (K08.883, K08.2195, type 2A.15b), 653 (K12.1140, type 2B.3), 654 (K10.46, type 2B.4a), 662 (K12.228, type 5A), 655-657 (K08.846, K12.1927, K12.1549, type 2B.4), 658 (K12.663, type 2C), 665-666 (K12.1924, K12.482, type 5A), 667 (K09.892, type 6A), 669 (K12.362, type 6B), 671 (K09.1026, type 6B.1), 672 (K08.1128, type 6A.1b), 673, 675 (K12.800, K12.135, type 6C.8), 674 (K08.1231, type 6C.6a)

2.2.3.¹⁸ Other sites

The serial number of the sherds from other sites consists of the following elements: the abbreviation SS, which stands for 'Survey Sites'; the number of the survey site; a number cipher for the year in which the sample has been recovered ('10', which stands for 2010); the progressive number of the sherd.

The surface inventory of Site Survey 9 consists of 50 diagnostic sherds. All are wheelmade, and the vast majority (43) pertain to simple wares. Only seven samples have been recovered that pertain to other wares.

SS9 10.4 (Fig. 39: 718, Pl. 40: 7) is the only fine ware sherd found at the site. It is a brown burnished ware with a fine sandy fabric, fine texture, medium-high density and good sorting. Visible inclusions include small sands particles. The surface is carefully polished, with a glossy appearance. The shape is difficult to reconstruct on the basis of the preserved section, but general comparisons relate it to bowls. The other samples pertain to different variants of white/yellowish wash ware or burnished ware. Both fine sandy and medium/medium-coarse gritty fabrics are attested. SS9 10.50 (Fig. 40: 737, Pl. 40: 11) is a painted ware sherd with a single band in red colour over a thin clear buff wash. It is a body sherd of a closed shape. The fine fabric of the burnished sherd SS9 10.4 (Fig. 39: 718, Pl. 40: 7) finds a comparison in a fragment of handle with central upper digit (SS9 10.29 b, Pl. 40: 8), which has a well smoothed surface with traces of burnishing. A thin, whitish slip seems recognisable on the surface, and is almost transparent. A thick, whitish slip, instead, is recorded in SS9 10.1 (Fig. 39: 719, Pl. 40: 6), pertaining to a curved bowl with inside thickened rim with pointed profile. The slip is found mainly on the outer surface and over the rim, while it is almost transparent on the inner side. The surface is carefully burnished, with dull finish on the inner side and glossy finish on the outer side. Despite the accurate surface treatment, however, the fabric is mainly coarse. A double coat is observed in SS9 10.2 (Fig. 39: 721). A thick red slip covers the outer surface. On the upper profile of the rim, it continues over a buff wash, which covers the inner surface. A thin buff wash also covers the outer surface of SS9 10.50 (Fig. 40: 737, Pl. 40: 11), which is a body sherd probably from a large vessel, characterized by relief decorations. Some similarities are visible among fabrics, which are principally gritty. Major inclusions are white and clear white elements, from small to large in size, and grey and reddish brown small grits. Overall, however, the group is not significantly homogenous.

The inventory of simple wares, instead, is more consistent, both in terms of surface finish and fabrics. Vessels usually have thin walls, a rough surface of reddish brown colour, and gritty fabrics. In terms of Uşaklı Höyük ware examples, they may be related to the so-called pseudo-brittle ware (the sherds with the thinnest walls) or with coarse grained ware (the thickest samples). Only a few examples

would seem closer to Uşaklı's plain ware. Nevertheless, with the exception of a few sherds, no precise correspondence with the Uşaklı examples has been observed.

The colour of the clayish matrix is red. The surfaces, usually both inner and outer sides, are also red, but considerably darker (2.5YR 5/6, red; 5YR 5/4, reddish brown). They are uncoated, well vitrified and non-porous. No careful finishing techniques have been employed: they have been left rough, feeling almost abrasive to the touch. Large grits, mainly flattened, are clearly visible. There is no clear difference between the appearance of the outer and inner surfaces, but marked fast throwing ridges are sometimes recorded on the lower section of the inner side of closed shapes.

The handle SS9 10.33 (Fig. 39: 733, Pl. 40: 4) stands out due to a peculiar, thin gold-coloured wash that recalls the Uşaklı Höyük gold wash ware. It has the same gold colour sparkling particles which is also most probably mica. Traces of the wash are found mainly on the outer surface, but the sparkling gold particles are abundant also over the inner surface.

The fabrics are sandy and gritty, mineral. They are usually of medium texture, with medium or medium-high density and poor sorting. The inclusions are generally abundant, ranging from small to large, and consist mainly of grits. The range of visible particles is quite homogeneous, but more or less depurated fabrics are attested, the inclusions differing in frequency and size. Two main fabric variants are attested.

A finer variant (SS9 10.9, Fig. 39: 731, Pl. 40: 4, and SS9 10.34), usually corresponding with the samples with thinner sides, presents small white inclusions in medium frequency, and sparse, small darkish-grey inclusions, and flattened reddish-brown inclusions of medium size, in medium-low frequency. Small vegetal inclusions in low frequency are also sporadically visible. Other kinds of inclusions are recorded in other samples, such whitish, large grits with rounded shape, or medium size grey grits.

Thicker sections present a larger amount of white grits, further whitish grits of flattened or angular shape, with low sphericity, and large and very large clear white inclusions. A markedly high inclusions frequency distinguishes the fabric of SS9 10.27 (Fig. 39: 734, Pl. 40: 9), which shows an abundance of whitish grits of angular shape and large size together with small clear, sparkling particles.

Judging from the colour of the fractures, firing conditions do not seem to have been particularly precise, suggesting relatively low temperature, short firing time and/or changing firing conditions.

The fracture of both the thinner and thicker examples are more or less markedly sandwich. The fractures of variants with finer fabric are mainly reddish, both with red core (2.5YR 4/8, red) and brownish margins (5YR 5/6, yellowish red) or vice-versa, thus suggesting probably changes in the firing conditions. Greyish cores are attested where the sides became slightly thicker (SS9 10.18, SS9 10.10, SS9 10.32, SS9 10.33).

The range of shapes is limited and standardized, consisting almost exclusively of high necked jars with marked orifice. The rims are either thickened (Fig. 39: 722-724), simple and slightly everted (Fig. 39: 727) or simple and outlined by a groove below them (Fig. 39: 725, 728). Most of the jars would have had handles, many examples of which have been found. They are generally broad and flattened in section, quite thin, and the surface are decorated with wavy lines or incised dots. Recovered bases are mostly flat.

However rough in terms of shaping and finish, the vessels frequently have decorative elements such as incisions, corrugations, thickenings and ridging. The angled carinations of most of the shapes add a further decorative value through the alternation of light and shade created on the surfaces. The main combinations of motifs consists of small incised horizontal bands and lines (Fig. 39; Pl. 40: 1-2), wavy lines, mainly located on the handles (Fig. 39: 734; Pl. 40: 9), thickened ridges with pointed profile (Fig. 39: 730-731) and short thickened bands with 'lace-like' patterns (Fig. 39: 723; SS9 10.17, Pl. 40: 1 and Pl. 40: 3). The most distinctive patterns, frequently located on flattened handles, are linear sequences of incised dots, (Fig. 39: 736; Pl. 40: 4, SS9 10.26, 28, 32) or short strokes (Fig. 39: 735; Pl. 40: 4, SS9 10.18). Lightly impressed wavy lines are also typical (Fig. 40: 738-739, Pl 40: 2, SS9 10.46-47).

With the exception of some examples that show evident traces of fire and most probably fall within the general functional horizon of kitchen ware, most of the examples seem to belong to a common ware functional horizon. Overall, the homogeneity of the simple ware repertoire found at the site suggests a single ceramic tradition. The technological and morphological properties of the vessels are mainly indicative of a fast and standardized production process.

References:

Pl. 40

Figs 39-40

2.2.4 The typology

2.2.4.1 Ceramic Classification Codes

Generic functional classification of wares (Cl)

C – Common ware
 K – Kitchen ware
 S – Storage ware
 F – Fine and luxury ware

Forming technique

W – Wheelmade
 H – Handmade
 WH – Mixed technique (Handmade and refined on the wheel)

Thickness of the wall

0 – indeterminable
 1 – Very thin (1-3mm)
 2 – Thin (3-5mm)
 3 – Medium A (6-10mm)
 4 – Medium B (11-15mm)
 5 – Thick A (16-20mm)
 6 – Thick B (more than 20mm)

General evaluation of the ceramic production

Ff – Very fine
 F – Fine
 Mf – Medium-fine
 M – Medium
 Mc – Medium-coarse
 C – Coarse

General types

1 – Plates
 2 – Bowls
 3 – Goblets and Small Jars
 4 – Craters
 5 – Neckless Jars
 6 – Necked Jars
 7 – Large Containers: deep, open
 8 – Large Containers: deep, closed
 9 – Lids
 10 – Stands
 11 – Strainers
 W – Undetermined Shapes: Scarcely preserved
 Z – Undetermined Shapes: Necked vessels/Craters/Large mouthed vessels

Other morphological components

20 – Beaks and spouts
 B – Bases
 H – Handles and lugs

2.2.4., *Morphological types**List of morphological types, variants and lesser variants*

1 – Plates

1A – Plate, simple

- 1A.1 – *Plate, simple*. Very open, straight sides
- 1A.2 – *Plate, simple*. Very open, slightly flaring sides
- 1A.3 – *Plate, simple*. Squared rim profile

1B – Plate, thickened/banded rim

1C – Plate, everted rim

1D – Plate, everted upper sides

1E – Plate, large, carinated

1F – Plate, curved sides

1G – Plate, simple, with rope impressions

1H – Plate, inside thickened rim, curved sides

- 1H.1 – *Plate, inside thickened rim, curved sides*. Slightly banded border
- 1H.2 – *Plate, inside thickened rim, curved sides*. Markedly thickened rim
- 1H.3 – *Plate, inside thickened rim, curved sides*. Low sides

1I – Plate, straight, low sides

1J – Plate, small, inturned sides

- 1J.1 – *Plate, small, inturned sides*. Pointed rim
- 1J.2 – *Plate, small, inturned sides*. Squared rim

2 – Bowls

2A – Bowl, simple

- 2A.1 – *Bowl, simple*. Thin walls, hemispherical body
 - 2A.1a – *Bowl, simple*. Thin walls, hemispherical body, rounded rim
 - 2A.1b – *Bowl, simple*. Thin walls, hemispherical body, slightly inside thickened rim
- 2A.2 – *Bowl, simple*. Very thin walls, vertical, pointed rim
- 2A.3 – *Bowl, simple*. Convex upper sides, thinned rim.
- 2A.4 – *Bowl, simple*. Inside pointed rim.
 - 2A.4a – *Bowl, simple*. Inside pointed rim. Thickened rim
 - 2A.4b – *Bowl, simple*. Inside pointed rim. Convex upper sides
 - 2A.4c – *Bowl, simple*. Inside pointed rim. Thickened, convex upper sides and thickened rim
 - 2A.4d – *Bowl, simple*. Inside pointed rim. Thickened rim and thin walls
- 2A.5 – *Bowl, simple*. Straight sides, thin
- 2A.6 – *Bowl, simple*. Vertical, straight sides
- 2A.7 – *Bowl, simple*. Straight sides
- 2A.8 – *Bowl, simple*. Straight sides, very open
- 2A.9 – *Bowl, simple*. Thick walls, inside thickened, bevelled rim
- 2A.10 – *Bowl, simple*. Very open, inside thickened, tapered rim
- 2A.11 – *Bowl, simple*. Outside thickened, tapered rim
 - 2A.11a – *Bowl, simple*. Outside thickened, tapered rim. Small. Thin walls, hinted tapered rim
 - 2A.11b – *Bowl, simple*. Outside thickened, tapered rim. Straight sides, hinted tapered rim
 - 2A.11c – *Bowl, simple*. Outside thickened, tapered rim. Curved sides
 - 2A.11d – *Bowl, simple*. Outside thickened, tapered rim. Curved sides, flattened, pointed rim
 - 2A.11e – *Bowl, simple*. Outside thickened, tapered rim. Curved sides, markedly thickened rim
- 2A.12 – *Bowl, simple*. Outside and inside thickened, rounded rim
- 2A.13 – *Bowl, simple*. Large. Outside thickened, tapered rim
- 2A.14 – *Bowl, simple*. Inside thickened, outside bevelled rim.
 - 2A.14a – *Bowl, simple*. Inside thickened, outside bevelled rim. Very open
 - 2A.14b – *Bowl, simple*. Inside thickened, outside bevelled rim. Inside bevelled rim
 - 2A.14c – *Bowl, simple*. Inside thickened, outside bevelled rim. Almost vertical

- 2A.14d – *Bowl, simple. Inside thickened, outside bevelled rim. Flaring sides*
- 2A.14e – *Bowl, simple. Inside thickened, outside bevelled rim. Outside thickened rim*
- 2A.15 – *Bowl, simple. Large. Straight sides*
 - 2A.15a – *Bowl, simple. Large. Straight sides. Thickened rim*
 - 2A.15b – *Bowl, simple. Large. Straight sides. Simple rim*
- 2A.16 – *Bowl, simple. Vertical upper sides, rounded rim*
- 2A.17 – *Bowl, simple. Deflected upper inner sides*
 - 2A.17a – *Bowl, simple. Deflected upper inner sides. Simple rim*
 - 2A.17b – *Bowl, simple. Deflected upper inner sides. Inside thickened rim*
- 2A.18 – *Bowl, simple. Upper convex sides.*
 - 2A.18a – *Bowl, simple. Upper convex sides. Large.*
 - 2A.18b – *Bowl, simple. Upper convex sides. Large. Squared rim*
 - 2A.18c – *Bowl, simple. Upper convex sides. Medium size. Inturned rim*
 - 2A.18d – *Bowl, simple. Upper convex sides. Small. Inturned rim*
 - 2A.18e – *Bowl, simple. Upper convex sides. Small.*
- 2A.19 – *Bowl, simple. Curved sides, inside bevelled rim.*
 - 2A.19a – *Bowl, simple. Curved sides, inside bevelled rim. Everted upper sides.*
 - 2A.19b – *Bowl, simple. Curved sides, inside bevelled rim. Inside thickened rim.*
 - 2A.19c – *Bowl, simple. Curved sides, inside bevelled rim. Inside and outside thickened rim*
 - 2A.19d – *Bowl, simple. Curved sides, inside bevelled rim. Slightly tapered rim*
- 2A.20 – *Bowl, simple. Curved sides, thickened rim.*
 - 2A.20a – *Bowl, simple. Curved sides, inside thickened rim. Vertical rim, with rounded profile*
 - 2A.20b – *Bowl, simple. Curved sides, inside thickened rim. Vertical rim, with flattened profile*
 - 2A.20c – *Bowl, simple. Curved sides, inside thickened rim. Vertical rim, with flattened profile, large size*
 - 2A.20d – *Bowl, simple. Curved sides, inside thickened rim. Small size.*
 - 2A.20e – *Bowl, simple. Curved sides, inside thickened rim. Markedly inside thickened rim*
- 2A.21 – *Bowl, simple. Curved sides and outside thickened, rounded rim*
- 2A.22 – *Bowl, simple. Inside and outside thickened rim*
 - 2A.22a – *Bowl, simple. Inside and outside thickened rim. Slightly thickened rim*
 - 2A.22b – *Bowl, simple. Inside and outside thickened rim. Vertical upper sides and markedly thickened rim*
 - 2A.22c – *Bowl, simple. Inside and outside thickened rim. Markedly thickened rim, with rounded profile*
- 2A.23 – *Bowl, simple. Vertical upper sides and outside thickened, pointed rim.*
- 2A.24 – *Bowl, simple. Large size, tapered rim.*
- 2A.25 – *Bowl, simple. Large size, various rim.*
- 2A.26 – *Bowl, simple. Large size, curved sides, flattened rim*
- 2A.27 – *Bowl, simple. Thickened rim with triangular section*
 - 2A.27a – *Bowl, simple. Thickened rim with triangular section. Simple*
 - 2A.27b – *Bowl, simple. Thickened rim with triangular section. Anti-splash*
- 2A.28 – *Bowl, simple. Grooved rim*
- 2A.29 – *Bowl, simple. Ledged rim*
 - 2A.29a – *Bowl, simple. Ledged rim with squared profile*
 - 2A.29b – *Bowl, simple. Ledged rim with tapered profile*
- 2A.30 – *Bowl, simple. Everted rim*
- 2A.31 – *Bowl, simple. Everted upper sides*
- 2B – *Bowl, carinated*
 - 2B.1 – *Bowl, carinated. Thin, everted upper sides and sharpened rim*
 - 2B.2 – *Bowl, carinated. Simple rim*
 - 2B.2a – *Bowl, carinated. Simple rim. Elongated upper sides*
 - 2B.2b – *Bowl, carinated. Simple rim. Small sizes and short, vertical upper sides*
 - 2B.2c – *Bowl, carinated. Simple rim. Small size and very short, inturned upper sides*

- 2B.3 – *Bowl, carinated*. Short, upper convex sides
- 2B.4 – *Bowl, carinated*. Inturned upper sides
 - 2B.4a – *Bowl, carinated*. Inturned upper sides. Intermediate upper section
 - 2B.4b – *Bowl, carinated*. Inturned upper sides. Elongated upper section
- 2B.5 – *Bowl, carinated*. Upper convex sides
 - 2B.5a – *Bowl, carinated*. Upper convex sides. Simple
 - 2B.5b – *Bowl, carinated*. Upper convex sides. Markedly inturned
 - 2B.5c – *Bowl, carinated*. Upper convex sides. Inside thickened rim
- 2B.6 – *Bowl, carinated*. Ribbed rim
- 2B.7 – *Bowl, carinated*. Upper convex sides and outside thickened rim
 - 2B.7a – *Bowl, carinated*. Upper convex sides and outside thickened rim. Vertical upper section
 - 2B.7b – *Bowl, carinated*. Upper convex sides and outside thickened rim. Inturned upper section
 - 2B.7c – *Bowl, carinated*. Upper convex sides and outside thickened rim. Markedly inturned upper section
- 2B.8 – *Bowl, carinated*. Upper convex sides and outside thickened, pointed rim
- 2B.9 – *Bowl, carinated*. Thin walls, inturned upper sides
- 2B.10 – *Bowl, carinated*. Thin walls, short, inturned upper sides and thickened rim
- 2B.11 – *Bowl, carinated*. Thin walls, inturned upper sides and tapered rim
 - 2B.11a – *Bowl, carinated*. Thin walls, inturned upper sides and tapered rim. Outside thickened rim
 - 2B.11b – *Bowl, carinated*. Thin walls, inturned upper sides and tapered rim. Outside and inside thickened rim
- 2B.12 – *Bowl, carinated*. Short, vertical upper sides and thickened rim
 - 2B.12a – *Bowl, carinated*. Short, vertical upper sides and thickened rim. Outside thickened, ledged rim
 - 2B.12b – *Bowl, carinated*. Short, vertical upper sides and thickened rim. Outside and inside thickened rim
- 2B.13 – *Bowl, carinated*. Inturned upper sides and everted rim
- 2B.14 – *Bowl, carinated*. Everted upper sides and thickened rim
- 2B.15 – *Bowl, carinated*. Short, vertical upper sides and outside thickened rim
 - 2B.15a – *Bowl, carinated*. Short, vertical upper sides and outside thickened rim. Straight upper sides
 - 2B.15b – *Bowl, carinated*. Short, vertical upper sides and outside thickened rim. Concave upper sides
- 2B.16 – *Bowl, carinated*. Vertical upper sides, tapered rim and marked carination
- 2B.17 – *Bowl, carinated*. Rounded rim and marked carination
- 2B.18 – *Bowl, carinated*. Inturned upper sides and outside thickened rim
- 2C – *Bowl, deep*
 - 2C.1 – *Bowl, deep*. Almost vertical sides
 - 2C.1a – *Bowl, deep*. Almost vertical sides. Squared rim
 - 2C.1b – *Bowl, deep*. Almost vertical sides. Rounded rim
 - 2C.2 – *Bowl, deep*. Upper convex sides and thickened rim
 - 2C.x – *Bowl, deep*. Sinuous upper sides
- 3A – *Small Jars*
 - 3A.1 – *Small Jars*. Simple, everted rim
 - 3A.2 – *Small Jars*. Outside thickened rim
 - 3A.3 – *Small Jars*. High neck
 - 3A.4 – *Small Jars*. Thin, high neck
 - 3A.5 – *Small Jars*. Incised rim
- 5A – *Neckless Jars*
 - 5A.1 – *Neckless Jar*. Simple rim
 - 5A.2 – *Neckless Jar*. Outside thickened, rounded rim
 - 5A.3 – *Neckless Jar*. Outside thickened, flattened rim
 - 5A.4 – *Neckless Jar*. Outside thickened, sharpened rim
 - 5A.5 – *Neckless Jar*. Everted rim

- 5A.6 – *Neckless Jar*. Outside thickened, tapered rim
- 5A.7 – *Neckless Jar*. Outside thickened, slightly ridged rim
- 5A.8 – *Neckless Jar*. Grooved under rim
 - 5A.8a – *Neckless Jar*. Grooved under rim. Thick walls
 - 5A.8b – *Neckless Jar*. Grooved under rim. Thin walls
- 5A.9 – *Neckless Jar*. With upper lug
- 5A.10 – *Neckless Jar*. Thin walls
- 5A.11 – *Neckless Jar*. Outside thickened, grooved rim
- 5A.12 – *Neckless Jar*. Small
- 6 – Necked Jars
- 6A – Jars with short neck
 - 6A.1 – *Jars with short neck*. Everted rim
 - 6A.1a – *Jars with short neck*. Everted rim. Very short neck
 - 6A.1b – *Jars with short neck*. Everted rim. Handmade
 - 6A.2 – *Jars with short neck*. Curved neck and simple rim
 - 6A.3 – *Jars with short neck*. Curved neck and outside thickened, tapered rim
 - 6A.4 – *Jars with short neck*. Thin walls and outside thickened, elongated rim
 - 6A.5 – *Jars with short neck*. Vertical neck and outside thickened, tapered rim
- 6B – Jars with medium size neck
 - 6B.1 – *Jars with medium size neck*. Curved neck and simple rim
 - 6B.2 – *Jars with medium size neck*. Collared neck, triangular rim
 - 6B.3 – *Jars with medium size neck*. Curved closed neck, thin walls and simple rim
 - 6B.4 – *Jars with medium size neck*. Collared neck, ribbed rim
 - 6B.5 – *Jars with medium size neck*. Curved neck, everted, outside thickened rim, medium mouthed
 - 6B.6 – *Jars with medium size neck*. Curved neck, everted rim, medium-small mouthed
 - 6B.7 – *Jars with medium size neck*. Curved closed neck, slightly everted, thickened rim
- 6C – Jars with high neck
 - 6C.1 – *Jars with high neck*. Straight neck, slightly everted/thickened rim
 - 6C.2 – *Jars with high neck*. Very small-mouthed, outside thickened rim with rounded profile
 - 6C.3 – *Jars with high neck*. Vertical neck, everted, thickened rim
 - 6C.4 – *Jars with high neck*. Straight, open neck and thickened rim
 - 6C.4a – *Jars with high neck*. Straight, open neck and thickened rim. Outside bevelled rim
 - 6C.4b – *Jars with high neck*. Straight, open neck and thickened rim. Everted rim
 - 6C.5 – *Jars with high neck*. Cylindrical neck, slightly everted, simple rim
 - 6C.6 – *Jars with high neck*. Flaring neck
 - 6C.6a – *Jars with high neck*. Flaring neck. Slightly everted, simple rim
 - 6C.6b – *Jars with high neck*. Flaring neck. Everted, thickened rim
 - 6C.7 – *Jars with high neck*. Outside thickened, squared rim
 - 6C.8 – *Jars with high neck*. Flaring neck, slightly everted/thickened rim, medium-large mouthed
 - 6C.9 – *Jars with high neck*. Trefoil mouthed
- 6D – Beak spouted jars
- 7A – Large Containers: deep, open
- 8 – Large Containers: deep, closed
- 8A – *Large Containers: deep, closed*. Medium-large size
 - 8A.1 – *Large Containers: deep, closed*. Medium-large size. Outside thickened rim
 - 8A.2 – *Large Containers: deep, closed*. Medium-large size. Sharply everted, rounded rim
 - 8A.3 – *Large Containers: deep, closed*. Medium-large size. Outside thickened, squared rim
 - 8A.4 – *Large Containers: deep, closed*. Medium-large size. Slightly everted, rounded rim
- 8B – *Large Containers: deep, closed*. Very large size
 - 8B.1 – *Large Containers: deep, closed*. Very large size. Outside thickened, squared rim
 - 8B.2 – *Large Containers: deep, closed*. Very large size. Outside thickened, rounded rim
 - 8B.3 – *Large Containers: deep, closed*. Very large size. Outside thickened rim with triangular section
 - 8B.4 – *Large Containers: deep, closed*. Very large size. Outside thickened, hooked rim
 - 8B.5 – *Large Containers: deep, closed*. Very large size. Everted, inside stepped rim

- 9 – Lids
- 10 – Stands
- 11 – Strainers
- W – Undetermined, scarcely preserved shapes
- Z – Undetermined Shapes
- ZA – *Undetermined Shapes. Large, necked vessels/craters*
 - ZA.1 – *Undetermined Shapes. Large, necked vessels/craters. Simple, tapered rim*
 - ZA.2 – *Undetermined Shapes. Large, necked vessels/craters. Everted, outside thickened rim*
 - ZA.2a – *Undetermined Shapes. Large, necked vessels/craters. Everted, outside thickened rim. Markedly everted, squared rim*
 - ZA.2b – *Undetermined Shapes. Large, necked vessels/craters. Everted, outside thickened rim. Elongated, rounded rim*
 - ZA.2c – *Undetermined Shapes. Large, necked vessels/craters. Everted, outside thickened rim. Markedly everted, rounded rim*
 - ZA.3 – *Undetermined Shapes. Large, necked vessels/craters. Outside thickened, tapered rim*
 - ZA.3a – *Undetermined Shapes. Large, necked vessels/craters. Outside thickened, tapered rim. Inside angled*
 - ZA.3b – *Undetermined Shapes. Large, necked vessels/craters. Outside thickened, tapered rim. Inside stepped*
 - ZA.4 – *Undetermined Shapes. Large, necked vessels/craters. Outside thickened, elongated rim with various profile*
 - ZA.5 – *Undetermined Shapes. Large, necked vessels/craters. Outside thickened, elongated rim with rounded profile*
 - ZA.6 – *Undetermined Shapes. Large, necked vessels/craters. Outside thickened, elongated rim with squared profile*
 - ZA.6a – *Undetermined Shapes. Large, necked vessels/craters. Outside thickened, elongated rim with squared profile. Simple*
 - ZA.6b – *Undetermined Shapes. Large, necked vessels/craters. Outside thickened, elongated rim with squared profile. Inside stepped*
 - ZA.7 – *Undetermined Shapes. Large, necked vessels/craters. Thickened rim with rounded profile, slightly stepped inner side.*
 - ZA.8 – *Undetermined Shapes. Large, necked vessels/craters. Vertical neck and everted rim, inner side stepped*
 - ZA.9 – *Undetermined Shapes. Large, necked vessels/craters. Intermediate between large, necked vessels and large, mouthed vessels.*
 - ZA.10 – *Undetermined Shapes. Large, necked vessels/craters. Markedly everted, globoid rim, stepped inside*
 - ZA.11 – *Undetermined Shapes. Large, necked vessels/craters. Various*
- ZB – *Undetermined Shapes. Probable small Jars. Slightly everted, straight sides/neck*
- ZC – *Undetermined Shapes. Large mouthed vessels*

Each morphological type is described extensively in a dedicated paragraph. In the individual paragraphs, the code of the ceramic type is followed by a label, so as in the list above, which is a generalized classification for an immediate identification of the type, and by an extended description. The extended description includes the characterization of: morphology; dimensions (average diameter; wall thickness); wares of reference; shaping technique; general evaluation of manufacture (fine/medium/coarse); general functional classification of the ceramic production (fine/common/kitchen/storage ceramic production); frequency within the ceramic inventory.

For each ceramic category a selection of drawings has been chosen to illustrate the main type of reference and, when the category is not entirely homogeneous, its main variations or its 'borderline samples' lying between one specific group and others. The problem of 'continuum' (Shepard 1985: 308; Orton, Hughes 2013: part II, chapter 6), possibly as a consequence of the specific nature of the assemblage, which covers a long span of time in a cultural context of relative continuity, proved to be significant. In some cases, in fact, the boundary between two distinct types had to be settled along a sequence of adjacent progressively changing variants, gradually filling the space between the two mor-

phological categories typified at origin at the extremes. A certain degree of overlap therefore is possible. A rather large number of types and sub-types, in fact, has been retained in some cases, in order to verify whether small variations might be connected to cultural or chronological significance, also in view of the continuation of investigations at the site.

A total of 5770 diagnostic potsherds were recovered on the surface. Among these, 5277 gave us information about wares. Further information about morphological frequencies was obtained from a total of 3514 potsherds, chiefly corresponding to rim sherds⁹⁴. Supplementary information on morphological aspects of the vessels inventory has been obtained from the counts of additional components such as bases (type B), beaks and spouts (type 20), and lugs and handles (type H), whose distribution has been considered separately⁹⁵.

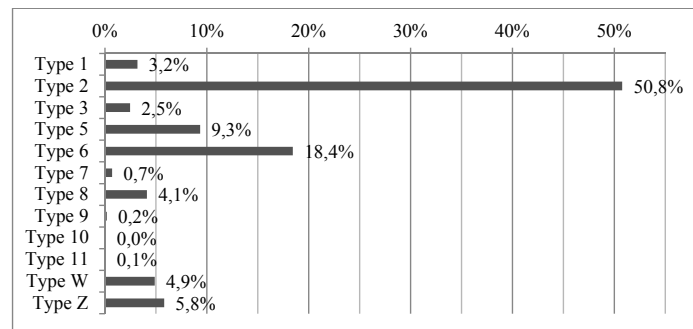


Diagram 5a: Occurrence of main morphological types⁹⁶ – *Code layout*.

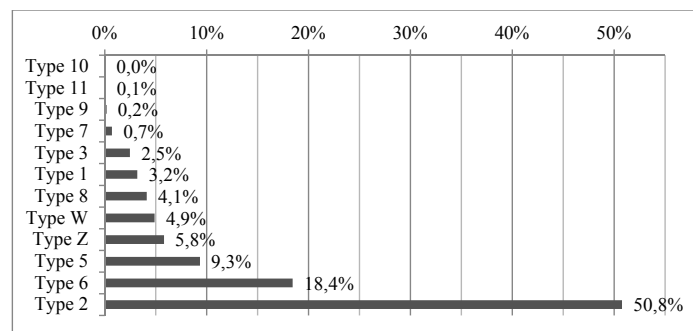


Diagram 5b: Occurrence of main morphological types – *Bottom-up layout*.

⁹⁴ The inventory of main shapes, which is generally indicated in the text below as the sum of the total, identified shapes, groups ceramic potsherds that can provide more or less precise information about the general shape of reference of the original vessel. This includes all of the processed ceramic samples which include a rim and which can be attributed to types 1-3, 5-11, W or Z. To these have been added pottery samples whose state of preservation enabled us to assign them to the morphological categories mentioned above.

⁹⁵ The potsherds in question (types B, H, and 20) are chiefly informative about specific, morphological aspects of the vessel components. They have been considered in the count of main shapes (see footnote 93) when comprehensive of a rim or when their state of preservation was sufficient to enable us to attribute to the morphological categories included within the inventory of main shapes.

⁹⁶ Percentages are calculated on a total of 3514 diagnostic sherds with identified morphology.

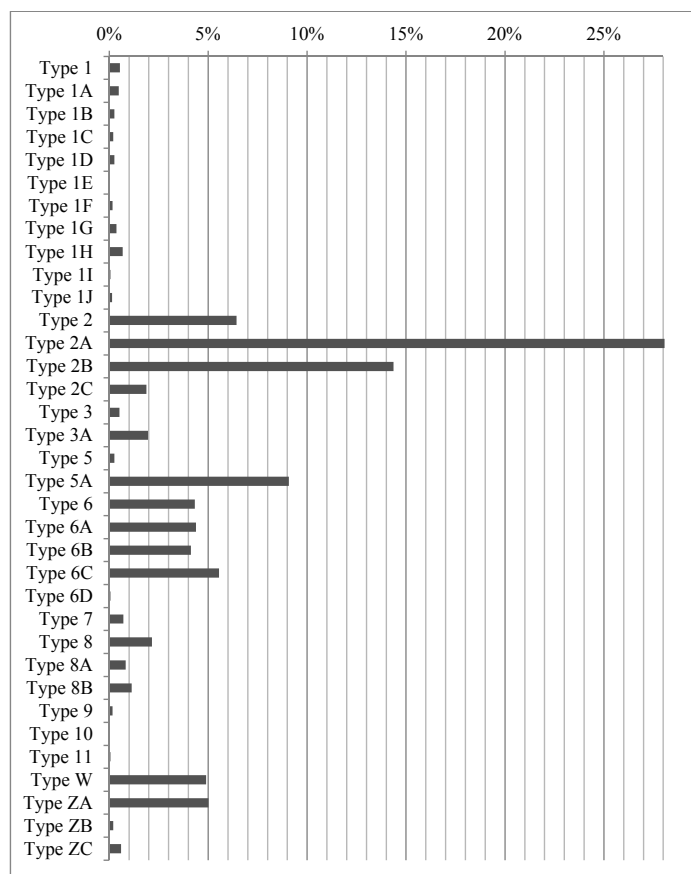


Diagram 6: Occurrence of main morphological types and variants⁹⁷.

1 – (nos 1-37, 642) – *Plates*. The cluster gathers very open rim sherds that most probably relate to shallow, open shapes like plates or casseroles. Ten main morphological variants (A-J) have been distinguished based on the profile of the body, the profile of the rim and the thickness of the walls. The most common variants are plates with outside thickened rim and curved sides (type 1H), followed in order of attestation by simple plates (type 1A) and simple plates with rope impressions (type 1G). Variants with intermediate incidence include plates with everted upper sides (type 1D) and plates with thickened, banded rim (type 1B); plates with everted rim (type 1C), curved sides (type 1F), and with small, inturned sides (type 1J) constitute minor variants, while plates with straight, low sides (type 1I) and carinated (type 1E) are sparse. Rim sherds whose state of preservation prevented attribution to the above-mentioned categories have been sorted under the general label of type 1. The morphology is primarily found in simple wares like kitchen, drab and plain wares, although a few examples are attested in different wares, such as brown burnished and red slip wares. The production quality is generally medium: coarser examples are also frequent, while finer examples are very rare. Overall, the general functional context of reference is mainly that of the common or of the kitchen ware ceramic horizons.

1A – (nos 1-7) – *Plate, simple*. The group comprises plates with homogeneous profile, quite open sides and plain rim⁹⁸. It includes three main variants: 1) with very open, straight sides, 2) with very open, slightly flaring sides, and 3) with squared rim profile. Although the incidence of the type among the totality of detected ceramic shapes is not substantial, amongst plates it is, instead, quite high, representing 15% of the inventory. Variant 1 is the most common, followed by variant 3, with variant 2, instead, being very rare.

⁹⁷ Percentages are calculated on a total of 3514 diagnostic sherds with identified morphology.

⁹⁸ That is, simple (non-thickened), and coherent with orientation of the vessel sides (see § 2.2.1., *Morphology*).

1A.1 – (nos 1-3) – *Plate, simple. Very open, straight sides.* This category includes rim sherds in a generally poor state of preservation and the group is, therefore, to be considered rather generic. The recovered samples are probably to be related to plates with quite open sides, the inclination of the wall being approximately 160°. Body walls are straight, mainly unbroken, but a slight, gentle discontinuity may be attested on the outer side (no. 3). In this case, the upper section is straight and everted. Rims are plain: simple, with mostly rounded profile. A slight oblique flattening may, however, be present on the outside, apparently as a result of the trimming of the mouth. Average rim diameter is 35cm, with variability ranging from 25 to 47cm. The wall-thickness is medium/large. The morphology is commonly found in association with simple wares (usually kitchen ware); it is wheelmade, with medium-coarse manufacture, and belongs to the kitchen ware ceramic horizon. The generic variant 1A.1 is quite frequent among plates, representing approximately 10% of the inventory, while its incidence is negligible in the total of detected ceramic types.

1A.2 – (no. 4) – *Plate, simple. Very open, slightly flaring sides.* Among the preserved ceramic sherds this is a *unicum*, intermediate between type 1A.1, from which it is distinguished by the slightly flaring sides, and type 1D. Body walls are slightly broken, with a gentle change in directrix of the profile. The lower section is straight and the upper section is straight and everted. The rim is simple, with mostly rounded profile. The diameter of the mouth is large (41cm), with medium/large wall-thickness. It is in kitchen ware, wheelmade, with medium quality manufacture, and belongs to the kitchen ware ceramic horizon.

1A.3 – (nos 5-7) – *Plate, simple. Squared rim profile.* Rim-sherds belonging to this group are generally poorly preserved. Body walls are primarily homogeneous, with straight profile, although minor, gentle discontinuities may be found on the outer side, corresponding with a slight thinning of the wall (no. 6). In this case, the vessel is very close to type IE (see no. 20) in appearance. The rim is simple, bevelled on the outside. Diameters vary from 25 to 49cm, although two main groups are recognizable: a smaller variant, with rim diameters between 25 and 35cm (nos 5, 7), and a larger variant, with diameters between 35 and 49cm (no. 6). The thickness of the walls is medium. The type is attested in brown burnished, plain and kitchen ware. It is wheelmade and of medium quality manufacture, and mainly belongs to the common and kitchen ware ceramic horizons. It has a medium/low frequency among plates (less than 5% among type 1), while its incidence is not substantial among the totality of detected ceramic types.

1B – (nos 8-23) – *Plate, thickened, banded rim.* The group gathers rim sherds relating to plates with homogeneous profile and straight sides. The rim, which is thickened on the inner/upper side, elongated, with squared, outside bevelled profile, shapes a large, flattened band around the mouth of the vessel. A few examples with very slight thickening of the rim have been included in the same group (nos 12-13), although they are two minority variants. The group is rather heterogeneous: the same shape or close varieties recurs, in fact, in different ratios of dimensions. Due to the limited state of preservation and to the type of manufacture, which is frequently medium-coarse, the determination of rim diameters is not always precise. However, as far as we can observe, rim diameters mainly vary from 30 to 50cm, with a peak around 39cm. Matching the variation of the vessel sizes, a rather high variability is recorded also in the thickness of the walls. Medium wall thickness, however, is the most common. The shape recurs essentially in simple wares. The recovered examples may be ascribed to the group of kitchen ware, but there is a relatively high variability in fabrics and surface treatments. A coarser group (no. 9, Pl. 19: 3, K09.382; no.10, Pl. 19: 1, K09.755; nos 11-13) is characterized by a medium-coarse fabric with grits and bare, untreated surface, with abundant irregularities and sometimes darkened by fire (no. 11). Some specimens, instead, present a finer manufacture (no. 8, Pl. 19: 3, K08.2000), including a finer fabric, with medium-high density and medium frequency of small mineral inclusions. The surface, which presents a sort of self-slip, is quite well smoothed, with traces of burnishing on the upper side. Traces of burnishing, in fact, are sometimes registered on the inner (no. 10, Pl. 19: 1, K09.755) or on the outer surface (no. 9, Pl. 19: 1, K09.382). A rope impression, evidence of a phase of the shaping technique, may be located on the outer side of the rim (no. 9, Pl. 19: 1, K09.382). As far as shaping techniques are concerned, analysis of comparable materials reveals that the body was first handmade, and the large banded rim subsequently added (Schoop 2011, 346). The state of preservation of most of the samples from the Uşaklı Höyük survey is limited to the rim plus a very small section of the main body, so a sound investigation of the building technique is not possible, but they seem in part to confirm the same production process. Irregular lines and fingered traces are evident on the rim surface of sherd no. 9 (K09.382, Pl. 19.1), while more regular horizontal lines are present on the small preserved section of the wall that may derive from wheel throwing. On the smaller example no. 10 (K09.755, Pl. 19.3), however, possible throwing lines are visible on the rim surface, partially obliterated by a bur-

nishing finish. On sherd no. 8 (K08.2000, Pl. 19.3), an accurate smoothing of the lower side surface of the rim and a light burnishing of the upper side, obliterated eventual throwing marks. The quality of the manufacturing ranges from medium-coarse to medium. Although a relation with the common ware ceramic production is possible for some of the specimens, the most probable functional context is that of the kitchen ware ceramic horizon. The incidence of this type among plates is intermediate (roughly 8%), but is far less in relation to the total of detected ceramic types. Close similarities, however, are evident with the plate type 1C, which bears a comparable banded border.

1C – (nos 14-17) – *Plate, everted rim*. The sherds belonging to this group are limited to the rim plus the very upper section of the wall, with too short a portion of the lower section remaining to enable them to be classified with certainty. The rim is composite: simple, with rounded profile, and everted, with eversion angle that may be either gentle (no. 15) or markedly sharp (no. 14). Mouth diameters vary between 28 and 38cm. Wall thickness is medium. The morphology is attested in simple wares (plain and kitchen wares). It is wheelmade, with medium/medium-coarse manufacture, mainly relating to the common and kitchen ware ceramic horizons. The frequency of the type among plates is medium-low (6%), although some similarity is visible with other variants. The outline of rim type 1C is quite close to that of the more frequent type 1B, evoking a similar band appearance. It is likewise close to type 1D, distinguished on the basis of the slightly gentler discontinuity in the upper portion of the vessels and the shortened upper section of the wall.

1D – (nos 18-19) – *Plate, everted upper sides*. Moderately discontinuous sides characterize this type, with a slight alteration in the directrix of the profile being located on the upper part of the vessel wall. No. 19 testifies to a particularly fluid discontinuity. The lower section is very open and straight; the upper section is short, open, and mostly straight. The rim is plain: simple, with rounded profile. There is a marked variability in mouth diameters, which range from 12 to 40cm. Most of the recovered examples belong either to a small (12-20cm) or a large variant (30-40cm). It is common in simple wares (plain, drab and kitchen ware), wheelmade, with sometimes smoothed surface and medium quality manufacture. The functional context of reference is mainly that of the kitchen or common ware ceramic horizon. The incidence of the type among plates is intermediate (around 8%), while it is not substantial among the totality of detected ceramic types. The morphology is very close to the less widespread types 1A.1 (compare no. 3, type 1A.1, and no. 19, type 1D), 1C and 1E.

1E – (no. 20) – *Plate, large, carinated*. The type is a *unicum* among the recorded sherds, set apart from type 1A.3 (see no. 6) and type 1D (see nos 18-19) by the evident carination of the exterior of the body. The profile is broken, with the discontinuity located on the middle-upper portion of the outer side of the vessel wall. The lower and upper sections are straight and open. The rim is plain: simple, with rounded profile. The rim diameter is large (43cm), and the thickness of the wall is medium-large, although a greater thickening is registered in the upper section of the vessel wall. It is in plain ware, wheelmade, medium-coarse manufacture, and belongs to the common ware ceramic horizon.

1F – (no. 21) – *Plate, curved sides*. This group contains rim sherds of plates with homogeneous profile, slightly curved (convex) sides and intermediate inclination of the sides⁹⁹. The rim is simple, with overall squared profile, outside bevelled. A slight groove may be present on the outer side profile of the rim (maybe a string impression) or under the rim. The rim diameter is medium or medium-small and the thickness of the wall ranges from medium to medium-large. Traces of fire are visible on the outer and inner surface of example no. 21. The morphology is common in simple wares (mainly kitchen ware); it is wheelmade, with medium/medium-coarse manufacture, related to either the kitchen or the common ware ceramic horizon. Among type 1 it has a medium-low recurrence (ca 5%).

1G – (nos 22-28) – *Plate, simple, with rope impressions*. This group comprises rim sherds relating to plates with homogeneous profile, straight, very open sides and large mouth. The inclination of the vessel walls, in most cases, is around 180° (see nos 25-27) or nearly so (no. 22). However, due to the poor state of preservation of some of the recovered examples and to their rough manufacturing, determining the inclination of the wall or the rim diameter is not always easy. The best preserved examples, moreover, suggest that the mouth profile may be irregular. Rims are plain, simple and coherent with the orientation of the vessel walls, with primarily squared profile, the outer margins being vertically oriented. They bear neat rope impressions (usually in a double, horizontal sequence), evidence of the shaping technique employed. Rim diameters seem to vary greatly, ranging from 30 to about 55cm, although most of the recovered samples may be divided between a smaller variant, with rim diameters

⁹⁹ The inclination of the walls, in fact, is around 135°, intermediate between that of the plates and of the bowls.

varying between 30 and 40cm (see, for example, nos 22, 24), and a larger variant, with rim diameters varying approximately between 40 and 50cm (such as, for example no. 23). The thickness of the wall is medium or medium-large. The morphology is typical of simple wares: kitchen ware prevails, although some examples are attested in plain ware (Pl. 19: 1, K09.1033). The production procedure probably includes the use of both wheel and handmade techniques, with manufacture ranging from medium to medium-coarse quality. This type belongs essentially to the kitchen ware ceramic horizon. The incidence of the group among plates is medium-high (around 12%), although the percentage of group 1G is not substantial among the totality of detected ceramic types.

1H – (nos 29-32) – *Plate, inside thickened rim, curved sides*. The group comprises plates with curved sides and rim types that are characterized by different sorts of thickening. Three main variants have been distinguished: 1) with slightly banded border, 2) with markedly thickened rim and 3) with low sides. While variants 2 and 3 are quite close, variant 1 is somewhat different and constitutes, in fact, a *unicum* which does not affect the general incidence of the type. Overall, the group is the most representative among plates (21% of type 1). Among the totality of detected ceramic types, instead, the percentage of group 1H is not particularly significant.

1H.1 – (no. 29) – *Plate, inside thickened rim, curved sides. Slightly banded border*. This group comprises rim sherds relating to plates with homogeneous profile, curved (convex) and very open sides. The rim is slightly thickened on the inside, elongated, with the outer side profile rounded. The appearance, especially of the mouth, is quite close to that of some of the banded plates (see type 1B, especially nos 11-13), although here rim and wall profiles are curved. The diameter of the rim is medium/medium-large, with medium wall thickness. Despite the absence of traces of fire, the gritty fabric and the typical reddish-brown colour of the matrix support an attribution to the kitchen ware and an interpretation in the common and/or the kitchen ware ceramic horizon. The type is wheelmade, with medium manufacture. The variant, which is slightly divergent from the others of type 1H, is a *unicum*.

1H.2 – (nos 30-31) – *Plate, inside thickened rim, curved sides. Markedly thickened rim*. This group relates to rim sherds from plates with homogeneous profile, curved (convex) and not very open sides. The inner side of the rim is thickened, with a profile that is rounded in the upper part and slightly pointed in the lower. Average diameter is 35cm, with a variation between 28 and 50cm. The wall thickness is medium/medium-large. Overall, the type is quite close to some variants of bowls with inside thickened rim (see for example type 2A.18, especially nos 137-139). The type is wheelmade, typical of simple wares (mainly plain and drab ware). Although the surface may be well smoothed, the manufacture is generally medium, supporting a relation with the common ware ceramic horizon. The variant is very frequent among plates (8%), while the percentage of group 1H.2 is not substantial among the totality of detected ceramic types.

1H.3 – (no. 32) – *Plate, inside thickened rim, curved sides. Low sides*. This group relates to rim sherds from plates with a slightly discontinuous profile, characterized by quite a slight discontinuity located on the upper part of the wall. The lower section is curved (convex) and very open; the upper section is curved (convex) and slightly turned inwards. The rim is thickened on the inner side, with rounded or slightly pointed profile. The shape is close to the variant 1H.2, but differs in that here the rim thickening is not so marked: the same appearance of an inside thickening indeed is supplied and emphasized by the slight curvature inwards of the upper section of the wall (see also other sub-variants of type 2A.18a). Average rim diameter is 28cm, while wall thickness is medium-large. It is mainly a drab ware type, but related morphologies have been recovered in other wares, such as brown burnished and red slip ware. It is wheelmade, sometimes with smoothed surface, and medium manufacture and pertains to the common ware ceramic horizon. The variant is the most representative among the detected variants of plates, representing 12% of the ceramic inventory. Among the totality of ceramic types, instead the percentage of group 1H.3 is not substantial.

II – (nos 33, 642) – *Plate, straight, low sides*. The category collects rim sherds relating to plates with homogeneous profile, short, straight sides and open, flat base. The group consists of only two examples, both preserved from the rim to the base connection, but they probably pertain to a different ceramic tradition: one is wheelmade (no. 33) and the other is handmade (no. 642, Pl. 15: 9, K08.1519). The wheelmade example has an outside thickened rim with slightly pointed profile. The rim diameter is large (44cm), and the wall thickness is medium. It is in plain ware, with trace of burnishing on the surface. It has medium manufacture and belongs to the common ware ceramic horizon. The handmade example has a simple rim, with rounded profile. The rim diameter is not known, while the thickness of the walls is medium-large. Traces of burnishing are present on the surface. It is of medium manufacture, and belongs to the common ware ceramic horizon.

1J – (nos 34-37, 582) – *Plate, small, inturned sides*. The group comprises small plates with slightly discontinuous profile. A slight discontinuity is located on the upper part of the wall and the short, upper section is vertically oriented. It includes two main variants essentially distinct based on the rim profile: 1) with pointed rim, and 2) with squared rim. The production is common and fine. The incidence of the type among plates is medium-low.

1J.1 – (nos 34-35, 582) – *Plate, small, inturned sides. Pointed rim*. This group comprises rim sherds relating to plates with slightly discontinuous profile. A slight, gentle discontinuity is located on the upper part of the wall: the lower section is essentially straight and very open; the upper section is vertically oriented (though some examples may be somewhat more open, see no. 34), with curved (convex) profile. The rim is plain: simple, in axis, with mostly pointed profile. Rim diameters are generally medium/medium-small, ranging approximately from 20 to 30cm. Walls may be quite thin (see no. 35) or medium thick. The type is attested in brown wares (Bb, Rb), with burnished surface. The manufacture is fine or very fine, and in terms of ceramic production the type is essentially to be located within the generic functional class of fine wares. The group comprises mainly poorly preserved sherds (mainly consisting of a portion of the rim plus the upper section of the wall), but a complete profile with tripod base seems to belong to the same group (no. 582, Pl. 26: 2, K08.569, also shown in Pl. 29). The frequency of the type is very low. As far as morphology is concerned, however, it is quite close to some bowls of lesser variants such as types 2A.2c, 2A.2d and 2B.5b.

1J.2 – (nos 36-37) – *Plate, small, inturned sides. Squared rim*. This group comprises rim sherds relating to small plates with slightly discontinuous profile, similar to 1J.1. A slight, gentle discontinuity is located on the very upper portion of the wall, somewhat like an inturned rim, whilst the lower section is essentially straight and very open and the short, upper section is mostly vertically oriented. The discontinuity may be quite sharp in some cases (see no. 36). The rim is plain: simple, in axis, with squared, outside bevelled profile. Rim diameters are smaller than in variety 1J.1 (13-15cm), whereas body walls are slightly thicker. The type is attested in plain ware (no. 37), and in red slip ware (no. 36). The outer and inner surface of n. 36 are completely covered with a well preserved (with the exception of carination lines), thick reddish-brown slip, well burnished. Both examples are wheelmade; the manufacturing technique of the plain ware example is medium, suggesting a common ware ceramic horizon; the red slip ware example is of quite fine manufacture, suggesting a fine ware ceramic horizon. The percentage of group 1J.2 is not substantial.

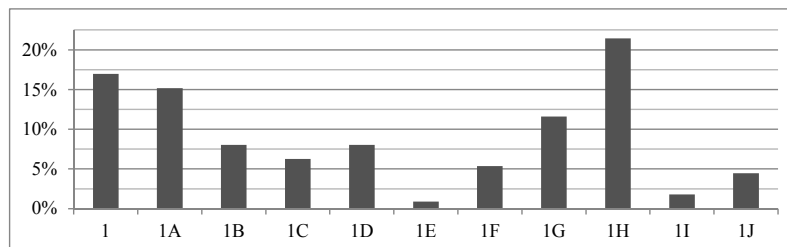


Diagram 7a: Type 1-Plates. Occurrence of main variants¹⁰⁰ – *Code layout*.

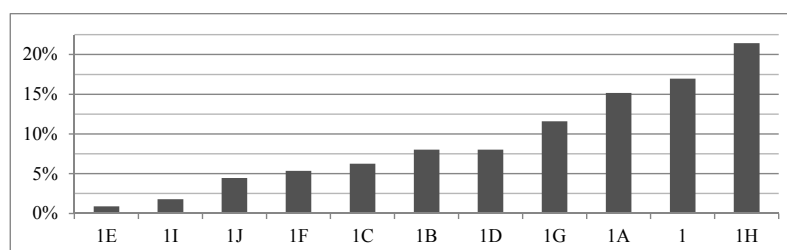


Diagram 7b: Type 1-Plates. Occurrence of main variants – *Bottom-up layout*.

¹⁰⁰ Percentages are calculated on the total of 112 type 1 diagnostic sherds.

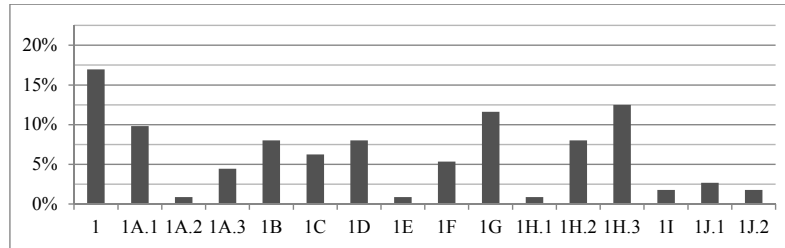
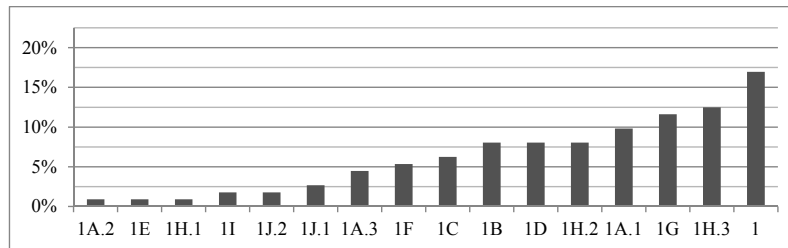
Diagram 8a: Type 1-Plates. Occurrence of main variants and sub-variants¹⁰¹ – Code layout.

Diagram 8b: Type 1-Plates. Occurrence of main variants and sub-variants – Bottom-up layout.

2 – (nos 38-344, 643-661) – *Bowls*. This category consists of rim sherds whose morphology might be ascribed to small or medium sized open shapes that are in close relation to bowls and/or cups. The average inclination of the sides of a bowl, that is, the angle formed between the base (or the plane, when the base is not preserved) and the walls, is around 135°, but very open (angle around 157.5°) or almost vertical examples (angle close to 90°) are also attested. Those in which the upper section of the walls is bent inward (upper inturned sides), but that can still be related to the general functional category of bowls and cups, have been included in this group. The cluster comprises three main sub-categories: A) simple; B) carinated, and C) deep. These are all further subdivided into main and lesser variants for a total of ninety-two bowls types.

By far the most representative (more than 55% among the group of bowls and around 28% among total types) are the simple bowls (type 2A), which are further subdivided into thirty-one main variants and forty-one lesser variants, for a total of sixty bowl types. Carinated bowls (type 2B), although far less frequent than simple bowls, also represent an important proportion of the ceramic inventory (28% of bowls and 14% of the total ceramic types). They are sorted into eighteen main variants and sixteen lesser variants, for a total of twenty-eight bowl types. Deep bowls (type 2C), instead, are very rare (4% of bowls and 2% of total ceramic types), but they might be slightly under-represented, since only those sherds where a sufficient section of the profile was preserved were retained for counts. They are sorted into three main variants and two lesser variants, for a total of four bowl types. A small percentage of rim sherds (13% *ca.* among bowl types and 6% *ca.* among total ceramic types) was sufficiently preserved to be ascribed to the group of bowls (generic type 2), but not enough to be assigned to more precise categories. Following the same principle, other slightly dubious sherds were assigned to the categories of 2A (6% *ca.* among bowls), 2B (1.5% among bowls), 2B.4 (0.22 % among bowls) and 2C (2% *ca.* among bowls) without, however, any specific sub-categorization being indicated.

2A – (nos 38-222, 643-651) – *Bowl, simple*. This category comprises rim sherds with either continuous or discontinuous profile that are characterised by the absence of sharp points of discontinuity or carinations. The group includes thirty-one main variants and forty-one lesser variants, for a total of sixty bowls types. The cluster is large and heterogeneous, varying both in terms of wares and of manufacturing quality. Major general, functional contexts of reference, however, relate principally to the common and, more rarely, to the fine ware ceramic horizons.

¹⁰¹ Percentages are calculated on the total of 112 type 1 diagnostic sherds.

2A.1 – (nos 38-47) – *Bowl, simple. Thin walls, hemispherical body.* To some extent, this group may be qualified as ‘generic’. It encompasses rim-sherds whose state of preservation varies from good (see for example no. 41, where the rim and a long section of the body profile is preserved) to very poor (see, for example, no. 46 where the rim and a very scanty percentage of the body profile are preserved). The morphology refers to open rim-sherds, simple, with medium-thin and thin walls. The group includes two main variants characterized by: a) simple rim with rounded profile, and b) a slight thickening of the inside of the rim. For the most part (87%) the type is attested in simple wares (mainly plain ware, followed by drab ware), but a small percentage of red slip ware (6%) and brown burnished ware examples (5%) are also attested. Painted specimens (2%) may be considered occasional. The manufacture is generally of medium quality, confirming a relationship with the common ware ceramic horizon. It is the most frequent group of bowls, representing around 9% of the inventory and bearing a marked relevance (5% approximately) also among the total sum of types registered.

2A.1a – (nos 38-41) – *Bowl, simple. Thin walls, hemispherical body, rounded rim.* This category comprises open rim-sherds with continuous profile, curved sides and plain rim (simple and in axis) with rounded profile (nos 38-39). Numbers 40-41, which show a very slight, gentle discontinuity in the upper section of the wall, with the upper section tending to a vertical orientation, illustrate borderline cases between type 2A.1a, 2A.2 and 2A.16¹⁰². The vast majority of rim diameters range between 15 and 30cm, but smaller examples are also attested. Wall thickness is medium-small. The shape is typical of simple wares (plain ware, like nos 39-40, and drab ware, like no. 38, see also Pl. 18: 1, K08.1019, shown also in Pl. 31), but related types are attested also in other wares (brown burnished ware, like no. 41, or red slip ware, Pl. 16: 2, K08.1858; Pl. 17: 2, K08.2123). Wheelmade, the quality of the fabric is mainly medium, although medium-fine examples are also attested. The ceramic horizon of reference is that of the common ware. Overall, this type is very frequent, representing approximately 4% of bowls: the slight heterogeneity of the group, however, must be considered as partially responsible for such a high recurrence.

2A.1b – (nos 42-47) – *Bowl, simple. Thin walls, hemispherical body, slightly inside thickened rim.* As for type 2A.1a, this category comprises open rim-sherds with continuous profile and mainly curved sides. The distinctive trait is the slight, inside thickening of the rim: the group, in fact, contains different variants of rim profiles which share a small pointed end on the inner side, for the most part inside bevelled (nos 42-45) and outside bevelled in other cases (nos 46-47). The majority of rim diameters range between 15 and 20cm, although smaller examples are also attested. Wall thickness is small. The shape is typical of simple wares (plain ware, like nos 42-43, and drab ware, like no. 44), but related types are attested in red slip ware (like no. 46), brown burnished ware (like no. 45) and, occasionally, in painted ware (like no. 47). Wheelmade, the quality of the fabric is largely medium or medium-fine, suggesting a relation with the common ware ceramic horizon, although some of the red slip ware specimens seem to be slightly finer. This type is one of the most widespread among bowls (approximately 5%). Moreover, similarities are visible with bowls 2A.4d, where the thickening of the rim is more marked, with some of the smaller variants of bowls 2A.17b (see nos 132-133), where rim profiles are more clearly rounded, and with bowls 2A.20b.

2A.2 – (nos 48-62) – *Bowl, simple. Very thin walls, vertical, pointed rim.* The category includes open rim-sherds characterized by thin walls and vertical, pointed rim. It encompasses three main variants distinguished on the basis of their body profile. Two of them have a moderate discontinuous profile, characterized by a slight, gentle discontinuity located on the upper portion of the wall; the lower section is open, mainly straight, whereas the upper section, very short, is vertically oriented, with straight (nos 48-52) or convex profile (nos 58-62). A third variant has a continuous, straight profile (nos 53-55, 57). The rims are mainly simple, with pointed profile, although one case with a minor inside thickening (no. 57) has been included. The majority of rim diameters vary from 15.5 to 20cm, but larger examples, especially of the variant with continuous, straight profile, are attested (see no. 57). Wall thickness is small or medium small. The moderate number of varieties isolated on the basis of the body profile corresponds approximately to the variation in wares. In the majority of cases, this type belongs to the simple wares horizon (mainly plain ware, such as nos 54-56 and 59-60, followed by drab ware, such as nos 58 and 61-62) but slipped wares are also attested, like brown burnished ware (nos 51-52, 57), red slip ware (nos 48-49) and yellow slip ware (no. 53). A single example of grey ware is also recorded

¹⁰² Compare especially no. 40 with no. 50 (type 2A.2, outside pointed rim) and 59-62 (type 2A.2, pointed rim, thin walled and slightly more marked discontinuity); no. 41 with nos 117-118 (type 2A.16).

(K12.1465, lot 11, band 8). Wheelmade, the quality of the fabric varies from medium to fine, suggesting a common ware ceramic horizon. The fine fabric is more frequent in red slip (no. 48), brown burnished (nos 51-52) and yellow slip specimens (no. 53, Pl. 30, K09.1233), a few of which could be ascribed to a fine ware ceramic horizon. A functional context among fine wares may, however, be proposed even for some of the plain ware specimens (see nos 54-55). This type is one of the most common among bowls (4.5%), maintaining some consistency even among the total types sum (3%). Some variants, especially those with convex upper sides, bear close similarities to other types, such as bowls 2A.1a, 2A.3, 2A.4b, 2A.17b¹⁰³ and 2B.5b.

2A.3 – (nos 63-67) – *Bowl, simple. Convex upper sides, thinned rim.* The group includes open rim sherds with discontinuous profile. A gentle discontinuity is located on the upper part of the wall. The lower section is open, with straight profile; the short, upper section, is vertically oriented, with essentially convex profile. No. 66 presents a clearer discontinuity that may be technically ascribed to the carinations (see types 2B.3 and 2B.4a), but the thickening of the upper section of the sides, as well as the rim profile, place the sherd within category 2A.3. Two slightly different variants are detectable: a small variant (nos 63-64), with rim diameters around 19-21cm and thin or medium-thin walls, and a large variant (nos 65-67), with rim diameters around 25cm and a typical thickening of the upper, convex section of the wall. The rim is simple, with rounded or pointed profile, typically thinned at its very end. The type is principally found in red slip ware: the large variant is attested in this ware only, although the smaller variant is also attested in brown burnished (no. 63) and plain ware (no. 64). A single example is recorded in grey ware (K12.2058, lot 12, band 5). The type is wheelmade. The fabric is mainly medium, and the general functional context of reference is that of the common ware ceramic horizon. The group has a low range of occurrence (it constitutes approximately the 0.5% of bowls), but this aspect must be correlated with the specificity of the group which, with the exception of the two variants noted above, is quite homogeneous.

The small variant bears close similarities to types 2A.2 and 2A.4a-b (compare nos 70, 72, in plain and grey ware). The vertical upper side of type 2A.3 finds a parallel in the carinated type 2B.2b. Faint similarities are visible with other typically red slip discontinuous profiles, like types 2B.2c, 2B.3, 2B.4a and 2B.5b, with inturned upper sides.

2A.4 – (nos 68-76) – *Bowl, simple. Inside pointed rim.* The group comprises open rim sherds of medium or small sizes with inside pointed rim. All of the specimens assigned to this category present a typical anti-splash device, principally made through an inside thickening of the rim, as in the variants 4a (medium-thick wall) and 4d (thin walled), or an inward curvature of the upper section of the wall, as in variant 4b. The variant 4c is a combination of both, with a typical thickening of the upper section of the wall and an accentuated inward curvature. The included variants are thus characterized by: a) thickened rim; b) convex upper sides; c) thickened, convex upper sides, and d) thin wall and thickened rim. The type is common both to drab ware and red slip ware specimens, but plain ware examples are also attested. The variant 4d, which is a *unicum*, is in grey ware. Average manufacture is medium, related to the common ware ceramic horizon. The frequency of the group is medium high (around 2% among bowls).

2A.4a – (nos 68-71) – *Bowl, simple. Inside pointed rim. Thickened rim.* This group includes slightly different kinds of bowls with inside thickened rim, embodying the larger alternative of type 2A.4d. The profile of the body is homogeneous and mainly straight. The rim profile is pointed on the inner side and mainly rounded on the outer side. Average rim diameter is 22-25cm, but larger examples are also attested (no. 68). The thickness of the walls is medium. The type, which is wheelmade, is chiefly found in simple wares (mainly drab ware, see no. 69), but similar red slip examples have been also found (nos 68, 71). With the exception of a few specimens where the fabric is fine (no. 69, drab ware) or medium-fine (no. 68, red slip ware), the type is usually associated with medium quality fabrics, relating to a common ware ceramic horizon. The incidence of the group is intermediate (it represents approximately 1% of bowls), but it shares a few similarities with other minor types such as 2A.3 and the other variants of type 2A.4 (2A.4b, c and d), 2A.14a (which is very open), 2A.14c-d (which is more closed) and 2A.18c.

2A.4b – (no. 72) – *Bowl, simple. Inside pointed rim. Convex upper sides.* This group includes a single example in grey ware, a rim sherd with discontinuous profile. A gentle discontinuity is located on the upper part of the walls: the lower section is open and straight and the short, upper section (oth-

¹⁰³ Compare nos 59-62 with 64 (type 2A.3); 72 (type 2A.4b, in grey ware); 132-133 (type 2A.17b, with inside thickened rim).

erwise to be considered as a diverging rim) is vertically oriented, with curved (convex) profile. The rim is simple, with pointed profile. The sizes of the bowl are medium, the diameter of the rim being around 19cm, with medium thickness of the walls. This specific bowl is in grey ware, wheelmade, with medium fabric, suggesting a common ware ceramic horizon. In terms of percentages, the type is not relevant. Some similarities, however, are visible with types 2A.2, 2A.3¹⁰⁴, 2A.17, 2A.18a and 2A.18c-d.

2A.4c – (no. 73) – *Bowl, simple. Inside pointed rim. Thickened, convex upper sides and thickened rim.* This category comprises open rim sherds of bowls with discontinuous profile. A gentle discontinuity is located on the upper part of the walls: the lower section is open, mainly with straight profile and the short, upper section is thickened, primarily vertically oriented, with a markedly curved (convex) profile. The rim is composite, simple, with pointed profile, and inturned. Average rim diameter is 20cm. This type, which is wheelmade, is characterised by thin walls and medium fabric, mainly relating to the common ware ceramic horizon. The frequency of the group is not substantial (less than 0.5% of bowls), but a slight similarity can be noted with type 2B.5b.

2A.4d – (nos 74-76) – *Bowl, simple. Inside pointed rim. Thickened rim and thin walls.* The group includes different types of bowls with inside thickened rim and thin walls, embodying the smaller variants of type 2A.4a. The profile of the body is continuous, mainly straight. The inside thickened and pointed rim has different kinds of outlines: elongated and outer side rounded (no. 74); slightly squared, inside bevelled (no. 75), or rolled (no. 76). Average rim diameter is 18cm, and the walls are typically thin. The most frequent are the red slip ware specimens (no. 76), but drab ware (nos 74-75) and brown burnished ware examples are also attested. The type is wheelmade, characterised by a rather fine manufacture, generally relating to the common ware ceramic horizon. The frequency of the group is not substantial (less than 0.5% of bowls). Some relations are, however, visible with the more frequent type 2A.1b, of which type 2A.4d may be considered a variant with clear anti-splash device. Inside bevelled rim specimens, instead, (see no. 75) find close parallels with other drab ware examples of type 2A.18e, with similar rim profiles.

2A.5 – (nos 77-78) – *Bowl, simple. Straight sides, thin.* This group includes open rim sherds and one complete profile of a bowl. The profile of the body is continuous and straight. The rim is plain (simple and in axis), with rounded (no. 77) or squared profile, outside bevelled (no. 78). Rim diameters vary between 20 and 35cm, whereas the thickness of the walls is more consistent, varying from thin to medium-thin. It is mainly a simple ware type. A single specimen has been found in brown burnished ware (K12.50, lot 9, band 2), while it is one of the typical shapes of orange slip ware (no. 77). It is mainly wheelmade, but a few examples of handmade, related morphologies are also attested (K08.1069, lot 2, band 2, and K12.1372, lot 11, band 7). Generally, the fabric is medium, suggesting a common ware ceramic horizon, but bowls nos 77 and 78 have a very fine fabric which can be related to either the common or the fine ware ceramic horizon. The incidence of the cluster is intermediate (around 1% of bowls) but, since it includes both fine and common ware examples as well as wheel and handmade specimens, it should be considered generic.

2A.6 – (nos 79-80) – *Bowl, simple. Vertical, straight sides.* The group includes open rim sherds with almost vertical orientation, homogeneous profile and straight sides. The rims are composite, outside thickened, with different kinds of profiles: squared and elongated (no. 79) or rounded, concave upper side (no. 80). In both cases, the outer lip of the bowl mouth is highlighted with a short band. Average rim diameter is between 20 and 25cm. Vessels have thin walls and fine fabric. The type is attested both in orange slip (nos 79-80 and Pl. 26: 1, K09.370) and plain ware. It is wheelmade, mainly related to the fine and common ware ceramic horizons. The percentage of the cluster is not substantial (less than 0.5% of bowls).

2A.7 – (nos 81-82, 648) – *Bowl, simple. Straight sides.* The group includes open rim sherds with straight, continuous profile. The rim is plain (simple and in axis), with slightly squared profile, outside bevelled (no. 81) or rounded (nos 82, 648). Average rim diameter is 30cm, and the wall is medium-thick or thick. Two main variants are attested: one is wheelmade (like nos 81-82) whereas the other is handmade (no. 648, Pl. 15: 10, K09.1211). Among the wheelmade variant examples, only simple wares are attested (mainly plain ware, like nos 81-82), while in the handmade variant, both plain (no. 648, Pl. 15: 10, K09.1211) and red slip ware samples are included. Both varieties have predominantly medi-

¹⁰⁴ Despite clear similarities with the type 2A.3, especially with the small variant (nos 63-64), the type 2A.4b had to be set apart on the basis of its greater wall thickening and the different kind of rim, lacking the typical final thinning of type 2A.3.

um fabric, and suggest a common ware ceramic horizon. Despite the simplicity and generic nature of the shape, the frequency of the group is relatively low (around 0.7% of bowls). It may be considered as the thicker variant of type 2A.5, whereas type 2A.8 represents a more open variant. Some very generic similarities are visible with type 2A.11b, which presents a neater cut of the rim profile, and with 2A.15a.

2A.8 – (no. 83) – *Bowl, simple. Straight sides, very open.* This group includes very open rim sherds, with continuous profile, straight. The rim is plain: in axis, mainly simple, with squared profile, outside bevelled. Average rim diameter is 30cm, and the wall thickness is medium. It is mainly a plain ware type, although a brown burnished example has been found (K12.1807, lot 12, band 1-2). It is wheelmade, with medium quality fabric. It belongs to the common ware ceramic horizon. The frequency of the type is not substantial. Overall, it may be considered as a more open variant of bowl types 2A.7, with slightly thinner walls. As far as rims are concerned, bowl 2A.8 is very close to some of the variants recorded among the group 2A.11b (see, for example, nos 93, 95), where a light thickening of the upper section of the wall results in an approximately triangular (or trapezoidal) rim profile.

2A.9 – (nos 84-86) – *Bowl, simple. Thick walls, inside thickened, bevelled rim.* This category comprises some of the minor variants of the type 2A.18a. The group includes open rim sherds with continuous profile. The sides have mainly curved profile (nos 84, 86), but straighter examples have also been included (no. 85). The sherds have in common the thickening of the inner section of the rim: rim profiles may differ, but all of them are flattened inside, slightly elongated and bevelled. Average rim diameter is between 30 and 35cm. The thickness at the level of the rim is quite large, and the body walls are also usually thick, but thinner examples have also been grouped together (see no. 86). The shape is chiefly found in simple wares (drab ware, like no. 84, Pl. 18: 5, K08.348, plain ware, like no. 86, Pl. 18: 3, K08.257). Small traces of a dark-red slip, however, are visible on the rim inner side surface of samples no. 85. It is wheelmade, with medium fabric, and belongs to the common ware ceramic horizon. The percentage of the type, which due to its slight heterogeneity may be considered 'generic', is not substantial. Some similarities, however, can be noted with other thick bowls with inside thickened rim such as type 2A.18a, more significant in terms of percentages.

2A.10 – (nos 87-89) – *Bowl, simple. Very open, inside thickened, tapered rim.* The group includes very open rim sherds with continuous, straight profile. The rim is composite: it is coherent with the orientation of the vessel walls, thickened on the inner side, with a slightly elongated outline. Its profile is flattened upper side, oriented horizontally or slightly sloping inner side (inside bevelled), outside rounded and inside pointed. The grooved rim bowl no. 89 instead is a *unicum*. Average rim diameter varies between 25 and 35cm, with medium and medium-thin walls. The type is mainly attested in simple wares (chiefly plain ware, like no. 88, but also in drab ware, like no. 87, Pl. 18: 5, K08.362a, also shown in Pl. 33); however, single examples of yellow slip ware (K12.985, lot 9, band 9) and grey painted ware (no. 89) have also been recovered. All of the sherds included within this category are wheelmade. With the exception of the grey painted bowl (no. 89), which is finer, the fabrics are generally medium, suggesting a common ware ceramic horizon. This type, which is very homogeneous, is not very frequent.

2A.11 – (nos 90-105) – *Bowl, simple. Outside thickened, tapered rim.* The category comprises open rim sherds characterized by a thickened, tapered rim. The dimension of the bowls varies from small (type 2A.11a and nos 102-103) to medium (types 2A.11c-e and no. 94), whereas large variants (no. 94) are rarer. Generally, the bowls are very open (see especially type 2A.11c), with straight (type 2A.11a-b) or curved sides (types 2A.11c-e). Typical tapered rims (see nos 97-99, 101-102) are outside thickened, slightly elongated, with upper profile flattened (nos 101-102) or rounded (nos 97-98), and pointed ending. A minor thickening may also be present on the inner side (nos 98-99). In addition to properly thickened and tapered rim bowls (types 2A.11c-d) the category 2A.11 also includes small bowls where this typical kind of rim is only suggested (types 2A.11a and 2A.11b). The variant 2A.11e, instead, comprises borderline examples intermediate between 2A.11 and 2A.12. The included variants are characterized by: a) small size, thin walls and only suggestion of tapered rim; b) straight sides and suggestion of tapered rim; c) curved sides; d) curved sides and flattened, pointed rim and e) curved sides and markedly thickened rim. The type is mainly connected with simple wares (81%); especially frequent are plain ware examples (56%), although drab ware specimens are also well attested (23%). Some related examples are found in red slip ware (9%) while orange and brown burnished, painted and grey wares specimens (9% on the whole) are only found occasionally. Average fabric is medium. The cluster is related to the common ware ceramic horizon. Overall, the group is rather sizeable (3% of bowls, and approximately 2% of total types sum).

2A.11a – (nos 90-92) – *Bowl, simple. Outside thickened, tapered rim. Small. Thin walls, hinted tapered rim.* The category includes rim sherds with quite open sides, continuous and mainly straight profile. The rim is slightly thickened with respect to the wall thickness: if the median axis passing along the bowl

walls is considered as a reference, the location of the rim thickening is to be considered external, but this is not very clear insofar as the profile appearance is mainly that of bowls with simple or simple and outside bevelled rim. It is coherent, moderately elongated, with upper lip generally rounded and horizontally oriented. Average rim diameter is small or medium small, around 18cm, and the wall thickness is small (no. 92 represents the thicker variant included). It is almost exclusively a plain ware type (no. 90, shown also in Pl. 26: 5, K09.1094), but drab ware (see no. 91) and brown burnished ware specimens (see no. 92) are also attested. Furthermore, a few examples included in the group (closer to type no. 92 than to nos 90-91) are in red slip ware. The type is wheelmade; it has medium quality fabric and may be ascribed to the common ware ceramic horizon. The frequency of the type is relatively low (less than 1% of bowls).

2A.11b – (nos 93-96) – *Bowl, simple. Outside thickened, tapered rim. Straight sides, hinted tapered rim.* The category includes rim sherds with quite open sides, continuous profile, mainly straight (see no. 96 for borderline reference of straight sides). The composite rims present average variations among minor examples where the thickening is only marginal (see no. 93), similarly to the rim types of bowls 2A.11a, and more evident outside thickenings (see nos 95-96). They are coherent, moderately elongated and tapered, with straight upper profile, mostly outside bevelled. The rim of no. 94, with small grooves, is a singular exception. The dimension of the bowls is medium: average rim diameter is 22cm, with medium to medium-thin walls. It is principally a plain ware type (see no. 94): drab ware examples are marginal (nos 93, 95), as are red slip ware specimens. It is wheelmade, with medium fabric and can be related to the common ware ceramic horizon. The type is well attested (slightly more than 1% of bowls), but not predominant. Overall, the shape presents some similarities with types 2A.7 and 2A.8.

2A.11c – (nos 97-100) – *Bowl, simple. Outside thickened, tapered rim. Curved sides.* The category includes rim sherds with quite open sides, with homogeneous, curved profile. Moderate discontinuities may be visible on the inner upper side (see nos 97-99), connected with the rim profile. The rim is composite: with a few exceptions where it may be considered vertically oriented (see no. 97), it is principally coherently oriented, outside thickened, slightly elongated, and tapered. A minor inside thickening is sometimes also attested (see no. 98). The upper profile of the rim is mainly horizontally oriented and rounded. Bowl sizes vary from medium-small (nos 97-99) to medium-large (nos 98, 100), with rim diameters ranging from 20 to 30cm. The wall thickness is medium. The type is predominantly attested in simple wares (both plain, like nos 98, 99, and drab ware, like nos 97, 100), although minor examples in slipped or self-slipped wares have been included in the same category on the basis of their similarity to no. 99 (Pl. 18: 5, K08.2049). It is wheelmade, with medium fabric, referable to the common ware ceramic horizon. The frequency of the group is not substantial (less than 0,5%). Some similarities are, however, to be found with other smaller bowls that are frequently found in slipped wares (see type 2A.19d). A similar rim typology is found in the larger bowls of type 2A.13 and 2A.24.

2A.11d – (nos 101-102) – *Bowl, simple. Outside thickened, tapered rim. Curved sides, flattened, pointed rim.* The category includes only two rim sherds, primarily associated on the basis of the specific rim morphology. They present quite open sides, with continuous, curved profile. A slight discontinuity is detectable in the very upper section of no. 102, connected with the rim construction. The orientation of the rim is almost coherent in one case (no. 101) and vertically set in the other (no. 102). The rim is outside thickened, flattened and tapered. The upper profile is horizontal (no. 101) or inside bevelled (no. 102). Bowls are medium to medium-large: rim diameters vary from 18 to 24cm, with medium thick walls. The two examples belong to two different wares: one is in plain ware (no. 101) and the other is in grey ware (no. 102). Both are wheelmade, with medium manufacture, related to the common ware ceramic horizon. The frequency of the type is not relevant, but similar rim typologies are found in the larger bowls that belong to types 2A.13 and 2A.24.

2A.11e – (nos 103-105) – *Bowl, simple. Outside thickened, tapered rim. Curved sides, markedly thickened rim.* The category, which may be considered 'heterogeneous', includes a series of bowls that are intermediate between variants 2A.11 and 2A.12. There are open and very open bowls with continuous, curved profile. The rim is composite: in axis and outside thickened. An inside thickening may also be present. The upper profile is rounded (nos 104-105) or squared (no. 103), obliquely oriented as in the outside bevelled bowls. No. 103 is the example closest to the 2A.11 group (compare with no. 96), whereas no. 104 is closer to group 2A.12. The dimension of the bowls is medium-large: rim diameters range from 19 to 30cm, with medium-thick walls. It is largely a simple ware type, mainly found in plain ware (no. 103), but a few examples of drab ware are also recorded (see no. 104). No. 105, instead, is an exception and is in kitchen ware. It is wheelmade, with a medium fabric, related to the common ware ceramic horizon. As far as percentages are concerned, the type is well attested, but not really widespread (less than 1% of bowls).

2A.12 – (no. 106) – *Bowl, simple. Outside and inside thickened, rounded rim.* The group comprises a single rim sherd, quite open, with continuous, curved profile. It has been isolated on the basis of the globoid rim. The rim is composite: in axis, outside and inside thickened, with rounded profile. The dimension of the bowl is medium-large: the rim diameter is 28cm, with medium wall thickness. It is in plain ware, wheelmade, with medium fabric, related to the common ware ceramic horizon.

2A.13 – (no. 107) – *Bowl, simple. Large. Outside thickened, tapered rim.* The group includes very open rim sherds of large size with typical outside thickened, tapered rim. In fact, it may be considered a larger and straighter variant of type 2A.11c. The rim is principally outside thickened, with a minor inside thickening. The rim profile is pointed outer side and rounded upper side, horizontally oriented. The dimensions of the bowls are large; average rim diameter, in fact, is 30cm, with medium or medium-thick walls. It is exclusively a simple ware type, mainly attested in plain ware. It is wheelmade, with medium fabric, related to the common ware ceramic horizon. The type is well attested but infrequent (0.5%). A similar rim typology is found in the smaller bowls belonging to types 2A.11c, 2A.11d and 2A.19d. Other similarities can be seen with types 2A.23 and 2A.24.

2A.14 – (nos 108-115) – *Bowl, simple. Inside thickened, outside bevelled rim.* The group includes a series of open rim sherds characterized by the presence of an inside thickened rim, mainly short, with rounded profile. The moderate flattening of the outer side profile of the rim gives the profile the appearance of a bowl with simple, outside bevelled rim, not very different from that of type 2A.11a. Within the group, five different variants are observed, distinguished on the basis of the side orientation (from very open to almost vertical), and rim peculiarities: a) with very open sides, b) with inside bevelled rim, c) with almost vertical sides; d) with flaring sides and e) with outside thickened rim. It is mainly a simple ware type (85% of group), attested for the most part in plain ware (79%). A few examples of red and brown burnished ware are also attested (12% of the whole), whereas other typologies (grey ware, painted ware) are sporadic. It is wheelmade. The manufacture is mainly medium, but a finer variant is also attested. Overall, the group seems mainly related to the common ware ceramic horizon. The incidence among bowls is rather high (more than 3%), maintaining some value also among the total types sum (1.65%). Most of the samples within the group, however, belong to shallow bowls variant *a*, which alone constitute 2.5% of the 2A.14 inventory. The other sub-variants, instead, are mainly sporadic.

2A.14a – (nos 108-110) – *Bowl, simple. Inside thickened, outside bevelled rim. Very open.* The category includes very open rim sherds, with continuous, straight profile. The rim is composite: it is coherent with the inclination of the vessel sides and inside thickened. The inner profile of the rim is mainly rounded, whereas the outer profile, although rounded in some cases (see no. 108) is slanted (or outside bevelled). Overall, the appearance of the profile matches with that of simple bowls with outside bevelled rim, suggesting that the particular conformity of the inside thickened rim had a functional and/or a technological significance. No. 110 is a borderline example where the inner profile of the rim is clearly different. The dimension of the bowls is medium: average rim diameter is highly variable, ranging from 16 to 27cm, with medium wall thickness. It is predominantly a simple ware type, most of the recovered sherds being in plain ware (see nos 108, 110) followed by drab ware (see no. 109), but similar shapes in red slip and brown burnished ware are also attested. It is wheelmade, characterised by generally medium quality manufacture, but sherds with finer fabric have also been recovered. It is to be connected with the common ware ceramic horizon. The group is quite frequent (representing 2.5 % of bowls) but, given the variability of the dimensions, it is to be considered slightly heterogeneous. Some similarity can be seen with bowls 2A.4a.

2A.14b – (no. 111) – *Bowl, simple. Inside thickened, outside bevelled rim. Inside bevelled rim.* The category includes open rim sherds with continuous, straight profile. The rim is composite: it is coherent with the inclination of the vessel side and presents a small thickening on the inner side, which appears to be related to technical rather than stylistic aspects. When considering the central axis of the sides of the bowl, a slight thickening is sometimes present also on the outer side (no. 111). Both the inner and the outer profile of the rim are bevelled. The dimension of the bowl is medium: average rim diameter ranges from 26 to 25cm, with medium wall thickness. The type, which is wheelmade, is almost exclusively attested in simple wares, and specifically it is found in plain ware (see no. 11): a single example of drab ware and a single example of brown burnished ware have also been identified. The fabric is mainly medium, although medium-fine examples have been also found. It is to be connected with the common ware ceramic horizon. The frequency of the group is rather low (around 0.5 % of bowls).

2A.14c – (nos 112-113) – *Bowl, simple. Inside thickened, outside bevelled rim. Almost vertical.* The category includes open rim sherds whose inclination is quite low, almost vertical in some cases. The

profile of the side is continuous, mainly curved. The rim is composite: it is coherent with the inclination of the vessel sides and presents a small inside thickening. Although more pointed examples are frequent, the inner profile of the rim is primarily rounded, whereas the outer profile is outside bevelled. The dimension of the bowls is medium, with average rim diameter around 25cm, with medium thickness of the walls. It is primarily attested in painted ware (no. 112 and Pl. 25: 2, K09.143): nevertheless, one example of red slip ware is also attested (no. 113). It is wheelmade, with medium fabric, related to the common ware ceramic horizon. The frequency of the type is not at all substantial, but some similarities can be seen with type 2A.4a.

2A.14d – (no. 144) – *Bowl, simple. Inside thickened, outside bevelled rim. Flaring sides.* The category includes a single sporadic fragment identified on the basis of peculiarities in the rim and sides. It is an open rim sherd with continuous profile, slightly flaring. The rim is composite: it is coherent with the inclination of the sides but presents an inside thickening with triangular profile, both the inner and the outer sides being bevelled. Compared to the other varieties of the group, the thickening of the inner side of the rim is more conspicuous. The dimensions of the bowl to which the rim refers to are medium: the diameter of the orifice is roughly 20cm, with medium thick walls. It is in plain ware, wheelmade, with medium fabric, related to the common ware ceramic horizon. It shares a few similarities with type 2A.4a. The type 2A.14d, of the same cluster, is a very close variant, distinguished on the basis of peculiarities of the rim profile.

2A.14e – (no. 115) – *Bowl, simple. Inside thickened, outside bevelled rim. Outside thickened rim.* This category includes a single sporadic fragment isolated on the basis of the peculiarities of the rim profile and of the ware. It consists of an open rim sherd, almost vertical. Apparently, it has a continuous, straight profile, but the poor state of preservation prevents a more certain classification. The rim is composite: it is coherent with inclination of the sides but presents a multiple thickening, a greater one inside and a lesser one outside. The profile of the rim is mainly squared, slightly outside bevelled on the upper side and more clearly bevelled inside. The dimensions of the bowl to which the rim refers to are medium: the diameter of the orifice is around 22cm, with medium wall thickness. It is in grey ware, wheelmade, with medium fabric, related to the common ware ceramic horizon.

2A.15 – (nos 116, 649-651) – *Bowl, simple. Large. Straight sides.* This group comprises large size bowls with medium thick walls and straight sides. It includes two main variants: a) with thickened rim and b) with simple rim. The former is mainly wheelmade, while the latter is handmade. The frequency of the type is not particularly substantial. Similarities, however, are visible with other straight side bowls of type 2A.7.

2A.15a – (no. 116) – *Bowl, simple. Large. Straight sides. Thickened rim.* This group comprises open rim sherds with continuous, straight profile. The rim is composite, coherent with the orientation of the vessel sides, inside and outside thickened, pointed outer side and rounded inner side. The sizes are medium-large, with diameters ranging from 25 and 37cm and medium-thick walls. The type, which is wheelmade, is attested in plain ware. The manufacture is medium, very possibly to be related to the common ware ceramic horizon. The frequency of the group is not substantial, but similarities can be noted with other straight side bowls of type 2A.7.

2A.15b – (nos 649-651) – *Bowl, simple. Large. Straight sides. Simple rim.* This group contains medium-large sizes open rim sherds with continuous, straight profile and simple rim. The rim is plain, coherent with the orientation of the vessel sides, simple, with rounded or slightly inside bevelled profile. The type is handmade, attested in plain and red slip wares. The manufacture is medium, suggesting a common ware ceramic horizon. The frequency of the group is not substantial, but there are similarities with the handmade variants of type 2A.7.

2A.16 – (nos 117-122, 646) – *Bowl, simple. Vertical upper sides, rounded rim.* The group includes open rim sherds with discontinuous profile. It is rather heterogeneous, comprising some minor variants of poorly preserved rim sherds. A slight, gentle discontinuity is located on the upper portion of the walls, dividing the vessel body into a lower, open section and an almost vertical upper section (nos 117-118) or slightly everted (nos 646, 119). Both the lower and the upper sections have almost straight profiles, but the discontinuity is so gentle as to convey the idea of a simple, curved body. The rim is plain, coherent with the orientation of the vessel sides, simple, usually with rounded profile. The bowls are of medium-small size, with 20cm average rim diameter and medium-thick walls. The variant with almost vertical upper sides is predominantly found in wheelmade, brown burnished ware, while the everted upper sides variant is found both in wheelmade (no. 119) and handmade red slip ware (no. 646). To the same group, two morphologically similar samples in handmade red slip ware have been ascribed that are characterized by a thick horizontal handle (nos 121-122). Overall, the manufactur-

ing quality is medium, suggesting a common ware ceramic horizon. The frequency is intermediate (around 1% of bowls). Some similarities can, however, be seen with types 2A.1a and 2A.17a.

2A.17 – (nos 123-133) – *Bowl, simple. Deflected upper inner sides.* This group comprises small to medium sized bowls with curved body. They are characterized by a slight deflection of the upper portion of the inner sides, which is directed toward the interior. Two main variants are distinguished: a) with simple rim and b) with inside thickened rim. The same impression of a deflection directed toward the interior of the vessel, in fact, is given by a discontinuity of the upper section of the inner sides in the variant *a*, while it is given by the inside thickening of the rim in the variant *b*. It is primarily found in simple wares (drab and plain ware), but similar shapes in red slip and yellow slip ware are also attested. Although the vast majority of the recovered samples belong to the sole variant *b*, the type has overall a high frequency among bowls (approximately 3%) maintaining some value also among the sum of the totality of the types (1.5%).

2A.17a – (nos 123-129) – *Bowl, simple. Deflected upper inner sides. Simple rim.* The group includes open rim sherds with curved sides. The profile is of a homogeneous outer side and discontinuous inner side. A slight discontinuity is located on the upper section of the inner side: it is directed toward the interior of the vessel if compared to the orientation of the sides of the vessels, but slightly everted if related to the baseline. The rim is plain, coherent with the orientation of the vessel upper sides, almost simple, with rounded profile. The sizes of the bowls vary from medium-small to medium, with medium/medium-thick walls. It is mainly a simple ware type, predominantly attested in plain and drab ware, although morphologically similar sherds are attested also in yellow slip ware (no. 128). It is wheelmade, with medium manufacture, related to the common ware ceramic horizon. The frequency of the group is not substantial (0.5% of bowls), but similarities are visible with types 2A.17b, 2A.4b, 2A.16 and 2A.20c.

2A.17b – (nos 130-133) – *Bowl, simple. Deflected upper inner sides. Inside thickened rim.* The group includes open rim sherds with curved, homogenous profile. The rim is composite, coherent with the orientation of the vessel sides, inside thickened, with rounded profile. The sizes of the bowls are medium-small, with thin to medium-thick walls. It is mainly a simple ware type, primarily attested in plain and drab ware. It is wheelmade, with medium manufacture, related to the common ware ceramic horizon. The type has a high range of occurrence among bowls (2.5%). There are, moreover, similarities with many other types, such as 2A.1b, 2A.2, 2A.4b, 2A.17a, and 2A.18a, of which type 2A.17b represents a sort of smaller variant.

2A.18 – (nos 134-156) – *Bowl, simple. Upper convex sides.* This category includes a series of bowls characterized by the presence of a slight anti-splash device, causing the upper section of the body walls to be convex. The anti-splash device is firstly engendered by an inward flexure of the very upper section of the body sides or, if we consider this section overall as the 'rim', by the inward flexure of the rim. The lip is therefore mainly inside bevelled (nos 137, 141-142, 144-147 and 149-156). The rim is mainly simple (nos 146-151, 154-156): a slightly thickening may be present (nos 142-145, 152-153) but, as this can only really be noted on the profile analysis, it suggests a functional or technical rather than stylistic value. The profile of the body is for the most part discontinuous, with a gentle discontinuity located on the upper part of the sides. In a few cases, however, the discontinuity may appear somehow sharper (type 2A.18b and no. 150-151), whereas in others the discontinuity point is so high as to be better described as a continuous profile bowl with inside thickened rim (see no. 152). Nos 154-156 represent variants where the discontinuity point is located lower on the bowl sides, being visible almost only on the outer contour whereas the inner one appears mainly continuous. The upper section of the body wall is vertically or inwardly oriented. The segment is so short in relation to its thickness (as noted before, it can be considered on the whole as a rim), that the description of its contour (straight or curved) does not convey much information but the gradual nature of the discontinuity causes the body to appear upper side convex. The group includes both larger (types 2A.18a-c) and smaller variants (types 2A.18 d-e). The rim may be simple (types 2A.18c-e) or slightly thickened (types 2A.18a-b). The type is primary a simple ware morphology, more frequently attested in drab and plain ware, but the smaller variants are found also in red slip ware. It is related to the common ware ceramic horizon. Overall, the group is one of the most frequent among bowls (ca. 7%) and maintains a relatively significant frequency among the whole inventory (ca. 3%).

2A.18a – (nos 134-143) – *Bowl, simple. Upper convex sides. Large.* The group includes open rim sherds with discontinuous profile. A slight discontinuity is located on the upper section of the walls: the lower section is open, either straight or curved. The short, upper section, largely corresponding with the rim, is either vertical or inturned, with convex profile. The rim is either simple or slight-

ly thickened on the inner side. The profile may be rounded or outside rounded and inside pointed. The reference type for the group is represented by no. 143, where a slight thickening of the rim is homogeneously present both inside and outside. Nos 134-140 represent, instead, borderline examples, where the anti-splash device is triggered by a more evident thickening of the rim inner margin, without side flexure (nos 137-140) or, inversely, by a sole inward flexure of the bowl upper sides (nos 134-136), that appear to be approximately vertically oriented. Envisaging different morphological devices, the group is strictly speaking heterogeneous. The recurring appearance of the examples is, however, that of curved bowls with slightly inturned or inside thickened rim. The sizes of the bowls are medium-large and large, with medium-thick to thick walls. It is primarily a simple ware type, mainly attested in drab and plain ware, but sporadic, similar morphologies are attested also in other wares. It is wheelmade, with medium manufacture, related to the common ware ceramic horizon. Among bowls type 2A.18, it is the most frequent sub-variant, representing alone 4% of bowls. Together with the other sub-variants of type 2A.18, type 2A.18a shows similarities with types 2A.4b, 2A.9, 2A.17b, 2A.20a and 2A.20e.

2A.18b – (nos 144-145) – *Bowl, simple. Upper convex sides. Large. Squared rim.* The group includes sporadic rim sherds of upper convex sides bowls which have been distinguished from the generic type 2A.18a on the basis of the characteristic thickened rim with squared profile. A discontinuity in the bowl profile is located on the very upper side, almost corresponding to the rim. The rim, slightly elongated and thickened, with squared profile, is inturned. The bowls are large, with average rim diameter of 33cm and medium-thick walls. The type is attested in plain and drab ware. It is wheelmade, with medium manufacture, related to the common ware ceramic horizon.

2A.18c – (nos 146-148) – *Bowl, simple. Upper convex sides. Medium size. Inturned rim.* The group includes medium size upper convex sides bowls whose gradual discontinuity, located on the very upper section of the sides, corresponds to a slight diversion of the rim toward the interior of the bowl. The rim is therefore composite: simple, inturned, with inside bevelled profile. The sizes of the bowls are medium, with marked variability in rim diameters and medium thickness of the walls. It is primarily a simple ware morphology, attested in plain and drab ware. A single sporadic rim sherd in red slip ware has been found with a similar morphology (no. 148). The type is wheelmade, with medium manufacture, related to the common ware ceramic horizon. The frequency of the type is intermediate (slightly more than 1% of bowls), but there are evident similarities, together with the other variants of type 2A.18 (see spec. type 2A.18c), with variants 2A.4a and 2A.4b.

2A.18d – (nos 149-151) – *Bowl, simple. Upper convex sides. Small. Inturned rim.* This group constitutes a minor variant of type 2A.18c, including small upper convex sides bowls whose gentle discontinuity, located on the very upper section of the sides, corresponds, as with type 2A.18c, to a slight diversion of the rim toward the interior of the bowl. The rim is therefore composite: simple, inturned, with inside bevelled profile. The sizes of the bowls are mainly small, with average rim diameters of 20cm and medium-thin walls. It is mainly a simple ware type, attested in drab and plain ware. It is wheelmade, with medium manufacture, related to the common ware ceramic horizon. The frequency of the group is insubstantial, although similarities can be seen with the other variants of type 2A.18 (see spec. 2A.18c and 2A.18e) and with 2A.4b.

2A.18e – (nos 152-155) – *Bowl, simple. Upper convex sides. Small.* This group constitutes a close variant of the type 2A.18d, including shapes intermediate between type 2A.18 and 2A.19. It comprises small upper convex sides bowls whose gentle discontinuity, located on the very upper section of the sides, corresponds to a slight diversion of the rim toward the interior of the bowl. If compared to the type 2A.18d, the diversion of the rim is lighter, in some cases vertically oriented. The rim is simple, markedly bevelled on the inner side. The sizes of the bowl are medium-small and small, with average rim diameters around 22cm and medium-thin/thin walls. It is mainly a simple ware type, attested in drab and plain ware, but rather similar morphologies are also attested in red slip ware. It is wheelmade, with almost medium manufacture, related to the common ware ceramic horizon. The frequency of the group is medium/medium-high (around 1.5% of bowls), and similarities are visible with the other variants of type 2A.18, with type 2A.4d and 2A.19a-b.

2A.19 – (nos 157-170) – *Bowl, simple. Curved sides, inside bevelled rim.* This group comprises different variants of open rim sherds whose rim typology progressively varies from simple, with inside bevelled profile, to more complex morphologies, like thickened outer and inner sides models. The group is rather heterogeneous. It includes four main variants: a) with everted upper sides and simple rim, b) with slightly everted upper sides and inside thickened rim, c) inside and outside thickened rim and, d) with slightly tapered rim. The variant *a* is primarily a red slip ware type, variant *b* is

mainly a simple ware type and the variant *c*, which is the most varied also in terms of morphology, is attested in brown burnished, grey, painted, yellow and red slip wares. The type is wheelmade, with almost medium manufacture, related to the common ware ceramic horizon. The overall frequency is rather high, representing approximately 3.5% of bowls. The most frequent variants are *c*, *b* and *a*, each representing around 1% of bowls. Variant *d* is, instead, only sporadic.

2A.19a – (nos 157-159) – *Bowl, simple. Curved sides, inside bevelled rim. Everted upper sides.* This group includes open rim sherds with discontinuous profile that are a close variant of bowl types 2A.18e, intermediate between types 2A.18 and 2A.19. A slight, gentle discontinuity is located on the middle portion of the walls. The lower section is very open, straight; the upper section, also straight, is everted, although it is inturned if related to the lower section of the sides, thus giving the general impression of a curved profile¹⁰⁵. The rim is plain: coherent with the orientation of the vessel sides, almost simple, and markedly bevelled inner side. The sizes of the bowl are mainly small, with average rim diameter of 20cm and thin walls. It is primarily a red slip ware type, but sporadic samples in other wares (plain, brown burnished and painted), are also attested. It is wheelmade, with medium manufacture, related to the common ware ceramic horizon. The frequency is intermediately low (slightly less than 1% of bowls).

2A.19b – (nos 160-161) – *Bowl, simple. Curved sides, inside bevelled rim. Inside thickened rim.* This category contains open rim sherds with discontinuous profile. As with bowls type 2A.19a, they present a slight, gentle discontinuity located in the middle portion of the wall, with a straight and open lower section and a straight and everted upper section that, being inturned with respect to the lower section, gives the impression of a curved body. The rim is composite: coherent with the orientation of the vessel sides, thickened inner side, with slightly rounded profile. The sizes of the bowl are medium small, with average rim diameters around 20cm and medium-thin walls. It is mainly a simple ware type, attested in plain and drab ware, but red and yellow slip ware, as well as brown burnished ware samples, are also attested. It is wheelmade, with medium manufacture, related to the common ware ceramic horizon. The frequency of the group is intermediate (around 1% of bowls). Similarities can be seen, however, with types 2A.18e, 2A.20c.

2A.19c – (nos 162-168) – *Bowl, simple. Curved sides, inside bevelled rim. Inside and outside thickened rim.* This group includes different variants of open rim sherds with curved sides and markedly thickened rim. The profile of the body is mainly homogenous and convex. No. 168 constitutes a borderline example, intermediate between type 2A.19c and types with more clearly discontinuous profile, like type 2A.19b (compare no. 215). The rim is composite: coherent with the orientation of the vessel sides or slightly diverging, vertically oriented. The profile of the rim is both outer and inner side thickened. The upper profile is mainly curved, bevelled inner sides. Internal and external margins may be slightly pointed. The sizes of the bowl is medium, with 22cm average rim diameter and medium thickness of the walls. It is more typically found in red slip and brown burnished ware, but yellow slip, painted and grey ware samples are also attested. It is wheelmade, with almost medium manufacture, related to the common ware ceramic horizon. The frequency of the group is intermediate (around 1% of bowls), although similarities may be noted with types 2A.19d, 2A.20c, 2A.22a-b and 2A.23.

2A.19d – (nos 169-170) – *Bowl, simple. Curved sides, inside bevelled rim. Slightly tapered rim.* This group includes sporadic open rim sherds with curved, homogenous profile. It is characterised by a composite rim: coherent with the orientation of the vessel sides or slightly diverging, vertically oriented, as in type 2A.19c. The profile of the rim is both outer and inner side thickened, rounded upper side and pointed outer and inner sides, slightly tapered. The sizes of the bowl are medium, with 22cm the average rim diameter and medium thickness of the walls. It is mainly a brown burnished and yellow slip ware type. It is wheelmade, with medium manufacture, related to the common ware ceramic horizon. The frequency of the group is not substantial, but some similarity can be noted with variants 2A.22a-b and 2A.23.

2A.20 – (nos 171-182) – *Bowl, simple. Curved sides, thickened rim.* This group comprises different variants of thickened rim bowls with curved sides. They are characterised by a rather feeble anti-splash device, engendered by a simple thickening of the inner side of the rim (variant *e*) or by a slight inside turning of the upper sides of the vessel (variants *a-c*). They have large (variants *a, c, e*) or medium-small/small rim diameters (variants *b, d*). Main differences have been sorted into five sub-

¹⁰⁵ A really curved profile has, in fact, been assigned to the same category (see no. 159).

types: a): with vertical rim and rounded profile, b) with vertical rim and upper side flattened profile, c) with vertical rim, upper side flattened profile and large size, d) with small size and e) with markedly inside thickened rim. The main reference for the cluster is represented by the variant *a*, which is a close typology of the typical drab ware bowl type 2A.18a, and secondarily by its *b* variant. It is chiefly a simple ware type, but similar examples are found also in other wares, such as brown burnished ware, painted ware and red slip ware. It is wheelmade, with medium manufacture, related to the common ware ceramic horizon. The overall frequency is rather high (around 2.5% of bowls).

2A.20a – (nos 171-172) – *Bowl, simple. Curved sides, inside thickened rim. Vertical rim, with rounded profile.* The group includes open rim sherds with curved sides and a slight anti-splash device, which is engendered by the thickening and the vertical deviation of the rim. The profile of the bowl appears almost homogenous outer side, while a discontinuity is located on the upper inner side, provoked by the inside bend in relation to the directrix of the lower body. The rim is composite: it is vertically oriented and thickened. It shows a particular globoid profile, which is rounded on the outer side and pointed on the inner. The sizes of the bowl are medium, with relatively large rim diameters (around 25-28cm) and medium thickness of the walls. It is mainly a simple ware type, attested in drab and plain ware, but similar morphologies are found in other wares as well (mainly brown burnished and red slip wares). It is wheelmade, with medium manufacture, to be related to the common ware ceramic horizon. It is by far the most frequent variant among type 2A.20 and the frequency among bowls is intermediate (slightly less than 1.5% of bowls), although similarities can be seen with the typical drab ware bowl type 2A.18a and with type 2A.20b.

2A.20b – (nos 173-176) – *Bowl, simple. Curved sides, inside thickened rim. Vertical rim, with flattened profile.* The group includes open rim sherds with slight anti-splash device that, similarly to bowl type 2A.20a, is engendered by the rim vertical deviation. The profile of the bowls is slightly discontinuous: a discontinuity is located on the upper section of the sides, almost coinciding with the rim. The open and mainly straight lower section, together with the vertical short upper section (rim), result in an overall curved body. The rim is composite: slightly thickened and vertically oriented, with flattened upper profile. The sizes of the bowls are medium-small, with average rim diameter around 20cm and medium-thin walls. It is mainly a simple ware type, but other wares are also attested, like brown burnished ware. The manufacture is of medium quality, related to the common ware ceramic horizon. The frequency of the type is not substantial, but some similarities can be seen with type 2A.1b and with type 2A.20a, of which type 2A.20b almost constitutes a sort of smaller variant with upper side flattened rim.

2A.20c – (no. 177) – *Bowl, simple. Curved sides, inside thickened rim. Vertical rim, with flattened profile, large size.* The group comprises sporadic open rim sherds with curved sides and a slight anti-splash device, engendered by the thickening and the vertical deviation of the rim. The profile of the bowl is homogenous on the outer side and discontinuous on the inner. The discontinuity is located on the middle portion of the wall. The lower part is open and straight; the upper part, which corresponds to the rim, is straight and vertically oriented. The rim is composite: it is vertically oriented and inside thickened, slightly elongated. The upper side profile is flattened, horizontally oriented. The sizes of the bowl are large, with average rim diameter of 30cm and medium-thick walls. In fact, it constitutes a larger variant of type 2A.20b. This type, which is wheelmade, with medium manufacture is attested in plain and brown burnished ware, related to the common ware ceramic horizon. Similarities can be noted with types 2A.17a (see spec. no. 129), 2A.19b and 2A.19c.

2A.20d – (nos 178-180) – *Bowl, simple. Curved sides, inside thickened rim. Small size.* This group includes sporadic small bowls with curved sides and slightly inside thickened rim. The profile of the bowl is continuous. The rim is composite: it is coherent with the orientation of the vessel walls and slightly thickened inner side, with rounded profile. The sizes are small, with average rim diameter of 16cm and medium thickness of the walls. The morphology is typical of painted ware, but attested in brown burnished ware as well. It is wheelmade, with medium manufacture, related to the common ware ceramic horizon. Similarities are visible with variants 2A.22a-b and 2A.23.

2A.20e – (nos 181-182) – *Bowl, simple. Curved sides, inside thickened rim. Markedly inside thickened rim.* The group comprises open or very open rim sherds with curved sides and slight anti-splash device engendered by the inside thickening of the rim. The profile of the bowl is homogenous. The rim is composite: coherent with the orientation of the vessel walls and inside markedly thickened. The profile of the rim is curved, upper side horizontally oriented and inner side pointed. The sizes are medium large, with average rim diameter of 28cm and medium-thick walls. It is mainly a simple ware type, but it is found also in brown burnished ware. It is wheelmade, with medium manufac-

ture, to be related to the common ware ceramic horizon. The incidence is not substantial, but there are similarities with some of the variants of type 2A.18a (see spec. no. 139).

2A.21 – (no. 183) – *Bowl, simple. Curved sides and outside thickened, rounded rim.* This category consists of a single, sporadic open rim sherd related to a curved bowl with outside thickened rim. The profile of the body is almost continuous. However, a gentle, light discontinuity is visible on the section of the drawing dividing the inner side between a lower, open segment and an upper vertical segment. The rim is composite: coherent with the orientation of the vessel walls and outside thickened, with rounded profile. The size is small, with rim diameter of around 17cm and medium-thin walls. The type is attested in red slip ware. It is wheelmade, with medium manufacture, related to the common ware ceramic horizon.

2A.22 – (nos 184-193) – *Bowl, simple. Inside and outside thickened rim.* The group includes different variants of curved bowls with outside and inside thickened rim. The profile of the rim is usually upper side horizontally oriented, with curved profile, and pointed or rounded at the outer and inner margins. Three main variants have been distinguished: a) with slightly thickened rim, b) with vertical upper sides and markedly thickened rim and c) with markedly thickened rim with rounded profile. The type is attested in different wares: it is predominantly found in painted ware, but red slip, brown burnished and yellow slip ware samples are also attested. The variant *c* is the only one that is found in plain ware. The bowls are wheelmade, with medium manufacturing, related to the common ware ceramic horizon. The range of occurrence of the type is overall relatively high (around 2.5% of bowls). Variant *c* is the most frequent, followed by variants *b* and *a*.

2A.22a – (nos 184-186) – *Bowl, simple. Inside and outside thickened rim. Slightly thickened rim.* This group includes open rim sherds with continuous profile, mainly curved. The rim is composite: coherent with the orientation of the vessel sides and slightly thickened. The profile of the rim is upper side horizontally oriented and flattened, slightly tapered outer side. The sizes of the bowls are intermediate, with average rim diameter of 25cm and medium thickness of the walls. It is primarily a painted ware type, but brown burnished and yellow slip ware samples are also found. It is wheelmade, with medium manufacture, very close to the common ware ceramic horizon. The frequency of the group is low, but similarities are visible with variants 2A.19c, 2A.19d and 2A.23.

2A.22b – (nos 187-189) – *Bowl, simple. Inside and outside thickened rim. Vertical upper sides and markedly thickened rim.* The group comprises open rim sherds with slightly discontinuous profile. A slight, gentle discontinuity is located on the intermediate portion of the walls. The open, lower section, together with the almost vertically oriented upper section, suggest an overall curved body. The rim is composite, coherent with the orientation of the vessel walls and markedly thickened on both the outer and inner side. The profile of the rim is upper side curved and horizontally oriented. Outer and inner side margins are pointed. Bowl no. 189 constitutes a borderline example, intermediate between types 2A.22a and 2A.23. The sizes of the bowl are intermediate, with 26cm average rim diameters and medium-thick walls. It is primarily a painted ware type, but similar morphologies are attested also in brown burnished and yellow slip ware. It is wheelmade, with medium manufacture, related to the common ware ceramic horizon. The frequency of the group is relatively low, but similarities can be seen with types 2A.19c, 2A.19d and 2A.23.

2A.22c – (nos 190-193) – *Bowl, simple. Inside and outside thickened rim. Markedly thickened rim, with rounded profile.* The group includes open rim sherds with continuous, curved profile. Frequently, the inclination of the sides is oriented almost vertically. The rim is composite: coherent with the orientation of the vessel walls and markedly thickened on both the inner and outer side. The profile of the rim is rounded, upper side horizontal or slightly bevelled inner side. The sizes of the bowls are medium-large, with 28cm average rim diameters and medium-thick walls. The morphology is attested in different wares, such as red slip, brown burnished and plain ware. It is wheelmade, with medium manufacture, related to the common ware ceramic horizon. The frequency of the group is intermediate (around 1% of bowls), but some similarity is visible with type 2A.23.

2A.23 – (nos 194-199) – *Bowl, simple. Vertical upper sides and outside thickened, pointed rim.* The group includes open rim sherds with discontinuous profile. A gentle discontinuity is approximately located on the upper portion of the wall: the open and mainly straight lower section, together with the vertical upper section, indicate an overall curved body. No. 196, which is characterized by a slightly sharper discontinuity point, represents a borderline example, intermediate between simple and carinated bowl types. The rim is composite: coherent with the orientation of the vessel walls and outside thickened, although a minor thickening may be present also on the inner side. The profile of the rim is upper side rounded, horizontally oriented; the outer side is tapered. The sizes of

the bowl are medium-large, with 30cm average rim diameters and medium-thick walls. The type is found mainly in brown burnished and red slip ware, although plain ware samples are also common. It is wheelmade, with medium manufacture, related to the common ware ceramic horizon. The frequency is medium (around 1.5% of bowls), but similarities are visible with many other types, such as 2A.13, 2A.19c, 2A.19d 2A.22a-c and 2B.12a.

2A.24 – (no. 200) – *Bowl, simple. Large size, tapered rim.* This group includes a single open rim sherd of large size with tapered rim. The profile of the bowl is almost continuous, although a slight discontinuity is visible on the upper portion of the outer side of the wall. The lower section is open and curved and the short, upper section is vertically oriented, but the overall appearance is that of a curved body. The rim is composite: coherent with the orientation of the vessel walls and thickened. The thickening is found on both the outer and inner side. The upper profile of the rim is curved, inside bevelled. The outer and inner profile are slightly pointed. The bowl is in plain ware, wheelmade, with medium manufacture, related to the common ware ceramic horizon. Some similarity can be seen with types 2A.11c-d, 2A.13 and 2A.23.

2A.25 – (no. 201) – *Bowl, simple. Large size, various rim.* The group includes a single, open rim sherd of large size that is characterized by a large, grooved rim. The rim is composite, vertically oriented and outside thickened, with flattened upper side profile. The bowl is in red slip ware. It is wheelmade, with medium-coarse manufacture, close the common ware ceramic horizon.

2A.26 – (nos 202-203) – *Bowl, simple. Large size, curved sides, flattened rim.* The group include simple, open rim sherds with curved, continuous profile. The inclination of the sides is open or almost vertical. The rim is plain: coherent with the orientation of the vessel sides and simple. The profile of the rim is squared or slightly rounded, horizontal or inside bevelled. The sizes are medium-large, with 32cm average rim diameters and medium-thick walls. The type, which is wheelmade, with medium manufacture, is attested in plain, pink slip and yellow slip ware, which are mainly related to the common ware ceramic horizon. The range of occurrence is not substantial.

2A.27 – (nos 204-209) – *Bowl, simple. Thickened rim with triangular section.* This group comprises a small number of open rim sherds that are characterised by a thickened rim with almost triangular section. It includes two main variants: a) simple, characterized by a rim that is thickened homogeneously both inside and outside and b) with anti-splash device, characterized by a greater inside thickening of the rim. It is mainly a simple ware type, although related morphologies are attested in red and yellow slip ware as well. It is related to the common ware ceramic horizon. The range of occurrence is not substantial.

2A.27a – (nos 204-206) – *Bowl, simple. Thickened rim with triangular section. Simple.* The group includes sparse, open rim sherds with curved, continuous profile. The upper portion of the walls, coinciding with the orifice of the bowl, progressively thickens toward the inner and outer sides, creating a triangular section. The upper profile of the rim is flattened and almost outside bevelled. No. 205, which is poorly preserved, constitutes a borderline example. The sizes of the bowl are medium, with 18cm average rim diameters and medium-thin walls. The morphology is found in plain, painted and red slip ware. It is wheelmade, with medium manufacture, related to the common ware ceramic horizon. The range of occurrence is not substantial

2A.27b – (nos 207-209) – *Bowl, simple. Thickened rim with triangular section. Anti-splash.* The group includes sparse, open rim sherds characterized by a more or less pronounced anti-splash device created by the inside thickening of the rim. The rim is, in fact, composite: coherent with the orientation of the vessel walls or slightly inverted and thickened. The main thickening is located on the inner side. The profile of the rim is outside bevelled, with sharpened outer and inner margins. The type, which is wheelmade, with medium manufacture, is found in plain and yellow slip ware, related to the common ware ceramic horizon.

2A.28 – (nos 210-211) – *Bowl, simple. Grooved rim.* This group comprises sparse rim sherds characterized by a variously grooved rim. The profile of the sides is curved, almost vertically oriented. The rim is composite: coherent with the orientation of the vessels walls and thickened both outside and inside. Two main groovings are located on the rim outer and inner sides. Both small and medium large sizes bowls are attested. The type is primarily found in plain ware, but red slip and coarse grained similar morphologies are also attested. It is wheelmade, with medium manufacture, related to the common ware ceramic horizon.

2A.29 – (nos 212-216) – *Bowl, simple. Ledged rim.* The group includes different types of bowl that are characterised by a thickened and elongated (ledged) rim. It includes two main variants: a) with squared profile, ledged rim, and b) with tapered, ledged rim. The first variant, which corresponds to a

sporadic rim sherd in brown burnished ware, is to be related to the fine ware ceramic horizon, while the second variant, mainly found in brown burnished and yellow slip ware, is slightly coarser, more likely to be related to the common ware ceramic horizon. The range of occurrence is not substantial.

2A.29a – (no. 212) – *Bowl, simple. Ledge rim with squared profile.* The category includes a single rim sherd of a fine ware bowl with ledge rim. The profile of the body is quite homogenous, but a slight discontinuity is visible on the upper, inner side, dividing the internal body into an open, lower section and an upper, vertical section. The rim is composite: coherent with the orientation of the vessel walls, outside thickened and elongated. The upper side profile of the rim is horizontal, slightly curved, while the outer side profile is squared. The size of the bowl is medium-small. It is in brown burnished ware, wheelmade, with fine manufacture, and it is related to the fine ware ceramic horizon.

2A.29b – (nos 213-216) – *Bowl, simple. Ledge rim with tapered profile.* The group includes different minor variants of bowl with ledge, tapered rim. The profile of the sides is almost discontinuous: a gentle discontinuity is visible on the upper portion of the sides creating, as in type 2A.29a, a lower, open section and a short, upper, vertical section. The rim is composite: coherent with the orientation of the vessel walls, outside thickened and elongated. The upper side profile of the rim is horizontal or slightly inside bevelled, while the outer side profile is sharpened and tapered. The morphology is found in small and medium sizes. It is attested in different wares, such as brown burnished, yellow slip and plain ware. It is wheelmade, with medium or medium-fine manufacturing, related to the common ware ceramic horizon. The range of occurrence is not substantial, but there is some similarity, together with its variant 2A.29a, with types 2A.30 and 2B.12a.

2A.30 – (nos 217-221) – *Bowl, simple. Everted rim.* The group includes open rim sherds with elongated, everted rim. The profile of the sides is quite homogenous, curved, almost vertically oriented. The rim coincides with the eversion of the upper walls, and is simple (non-thickened) and elongated. The sizes of the bowl are medium-small. The morphology is typical of painted ware, but similar samples in grey ware are also attested (no. 220). The type is wheelmade, with medium or fine manufacture, to be related to either the common or the fine ware ceramic horizon. The range of occurrence is not substantial, but some similarity may be seen with type 2A.29b.

2A.31 – (no. 222) – *Bowl, simple. Everted upper sides.* The category includes a single, sporadic rim sherd, probably of a bowl. Only the very upper section is preserved. It is markedly everted, with a terminal short, vertical section. The morphology, which is wheelmade, is in red slip ware, with medium-fine manufacture, probably to be related to the fine ware ceramic horizon.

2B – (nos 223-335, 652-657) – *Bowl, carinated.* The category includes open rim sherds with discontinuous profile characterised by a marked change in the directrix of the vessel walls or by the presence of a sharp discontinuity point (or carination). The marked change in the directrix of the vessel walls may be engendered by either a gentle bend or, more frequently, by a sharp angle¹⁰⁶. The family of carinated bowls includes 18 main variants and 16 lesser variants, for a total of 27 bowls types.

2B.1 – (nos 223-233) – *Bowl, carinated. Thin, everted upper sides and sharpened rim.* The group includes open rim sherds with discontinuous profile. A sharp discontinuity is located around the intermediate portion of the wall, dividing the straight and open lower section from the everted upper section, which has a slightly convex profile. The rim is plain: coherent with the orientation of the vessel walls and simple, with sharpened profile. The sizes of the bowl is medium-small, with rim diameters ranging from 14 to 22cm, and medium-thin to very-thin walls. Samples with slightly gentler carination point are documented by no. 227 and by nos. 232-233, which are further characterized by a very slight thickening of the inner side of the rim. It is mainly a red slip ware type, but plain ware and brown burnished ware samples are also attested. The variant is wheelmade, usually with fine manufacture, close to the fine ware ceramic horizon. The incidence of the group is relatively high (around 1.5% of bowls). Morphological similarities may be seen with type 2B.15b, which constitutes a coarser variant.

2B.2 – (nos 234-251) – *Bowl, carinated. Simple rim.* The group comprises carinated bowls with simple rim and mostly short, upper section, almost coinciding with the rim. It includes three main variants: a) with elongated upper sides; b) with small size and short, vertical upper sides, and c)

¹⁰⁶ Poorly preserved rim sherds whose morphological features were plainly related to more defined carinated types – or clearly distant from simple bowl types – have been included within the family of carinated bowls even in absence of an evident point of discontinuity. This is especially the case of rim sherds whose state of preservation was limited to the sole upper section of the vessel. The aforementioned methodological approach has been developed in order not to further multiply the number of small morphological sub-variants.

with small size and very short, inturned upper sides. It is mainly a red slip ware type, but similar morphologies are found in other wares such as plain, brown burnished and grey wares. It is wheelmade, related to the common ware ceramic horizon. The incidence of the group is high, representing around 3.5 % of bowls and maintaining some value also among the sum of total types. The vast majority of samples belong to variant *b* and a minority to variant *c*. The incidence of variant *a*, instead, is not substantial.

2B.2a – (nos 234-235) – *Bowl, carinated. Simple rim. Elongated upper sides.* The group includes sparse, open rim sherds with discontinuous profile characterized by a sharp discontinuity in the intermediate portion of the wall. The morphology of the bowls is close to the other variants of type 2B.2, but it is distinguished on the basis of the elongated upper section. The lower section is straight and open, while the upper section, also straight, is vertical or everted. The rim is plain: coherent with the orientation of the vessel walls and simple, with rounded profile. Both large and small examples have been found, in simple and red slip ware. They are wheelmade, with medium or fine manufacture, to be related to either the common or the fine ware ceramic horizon. The incidence of the group is not substantial, but similarities are evident with the type 2B.2b, of which it represents a minor variant.

2B.2b – (nos 236-246) – *Bowl, carinated. Simple rim. Small sizes and short, vertical upper sides.* The group includes open rim sherds with discontinuous profile. A sharp discontinuity is located around the upper portion of the wall: the lower section is straight, open or very open, and the short, upper section, almost coinciding with the rim, is usually vertically oriented. The rim is plain: coherent with the orientation of the vessel sides and simple. The upper profile is rounded or slightly bevelled. The sizes of the bowls are usually small, with small rim diameters and medium-thick walls, but larger (no. 236) or thinner (nos 244-245) samples are also attested that belong to the same morphological family. It is primarily a red slip ware type, although related morphologies are also attested in plain and brown burnished ware. It is wheelmade. Despite the presence of finer examples, the manufacture is generally medium, relating to the common ware ceramic horizon. The group has a high range of occurrence, representing around 2.5 % of bowls. Moreover, together with the other sub-variants of type 2B.2, some similarity can be seen with type 2A.3.

2B.2c – (nos 247-251) – *Bowl, carinated. Simple rim. Small size and very short, inturned upper sides.* The group includes open rim sherds with discontinuous profile that correspond to a minor variant of type 2B.2b. A sharp discontinuity is located on the upper portion of the walls. The lower section is straight and open. The very short, upper section, almost coinciding with the rim, is also straight and inturned, creating a sort of anti-splash device. The rim is plain: coherent with the orientation of the vessel upper sides and simple, usually inside bevelled. The sizes of the bowls are mainly small, with limited rim diameters (around 16cm) and wall thickness. It is primarily a red slip ware type, but sporadic, similar morphologies are found also in other wares, such as plain and grey ware. It is wheelmade, with almost medium manufacture, related to the common ware ceramic horizon. The frequency of the group is intermediate (around 1% of bowls), but some similarity is visible with type 2A.3.

2B.3 – (nos 252-255, 653) – *Bowl, carinated. Short, upper convex sides.* The group comprises open rim sherds with discontinuous profile. A gentle but substantial bend of the upper portion of the walls toward the interior of the vessel characterizes the profile of the body. Despite the rather gentle nature of the discontinuity point a substantial discontinuity is, in fact, located on the upper portion of the walls. The lower section is straight and open, almost vertical in some cases. The short, upper section, which may also be interpreted comprehensively as the rim of the bowl, is inturned, with convex profile. The rim is plain: coherent with the orientation of the upper walls of the body and simple, with rounded profile. Both medium and large sizes bowls are attested. The type is almost exclusively found in red slip ware. Related morphologies are attested both wheelmade (nos 252-255) and handmade (no. 653). The manufacture is medium, mainly related to the common ware ceramic horizon. The incidence of the type is not substantial, but some similarity is visible with types 2A.3, 2B.4a-b, and 2B.5b.

2B.4 – (nos 256-273, 654-657, 683) – *Bowl, carinated. Inturned upper sides.* The group includes bowl rim sherds with inturned upper sides, mainly with curved profile. Wheelmade examples (nos 256-273) mainly have carinated body, with medium-high carination and inturned upper sides, predominantly with curved profile. The discontinuity point is more or less sharp, but the change of orientation of the wall is always substantial. Triangular lugs, generally fragmented, have been frequently recovered fixed to the upper sections. There is a marked heterogeneity in the sizes of the bowls, which vary from medium-small to large. Two main variants have been identified on the ba-

sis of the length of the upper section of the walls: a) intermediate, and b) elongated. The type is predominantly found in red slip ware, but related morphologies are found also in plain ware. A few poorly preserved handmade sherds in red slip and painted ware probably belong to the same morphological family (nos 655-657, 683). Painted ware is limited to a single body sherd (no. 683). The red slip ware examples are preserved only on the very upper section, which is inturned, with markedly curved profile (nos 655-657). Two fragments of bowls with rather different sizes (nos 655-656) present a thin, semi-circular lug, located directly under the rim. The rim is simple, with inside bevelled profile. The manufacture is medium, related to the common ware ceramic horizon. The incidence of the group is definitely high. It represents around 4% of bowls and also has some value among the sum of total types (around 2%). The vast majority of samples belongs to variant *a*, while only a minority belongs to variant *b*. A small percentage of poorly preserved rim sherds has, instead, been attributed to the general family of 2B.4.

2B.4a – (nos 256-265, 654, 683) – *Bowl, carinated. Inturned upper sides. Intermediate upper section.* The group includes open rim sherds with discontinuous profile. A rather sharp discontinuity is located on the intermediate or upper portion of the walls. The lower section, when preserved, is open and straight. The upper section, whose length is intermediate, is markedly inturned, with either straight or slightly curved profile. The rim is mainly plain: coherent with the orientation of the upper sides of the vessel and simple. The rim is frequently slightly bevelled on the inner side, with either outside rounded and inside pointed profile or vice-versa. Horizontal lugs with triangular profile are frequently preserved, at least partially, above the carination point. There is marked variability in the sizes of the bowls, which vary from medium-small to medium-large. It is essentially a wheelmade red slip ware type, but related shapes in plain ware are also attested. Similar handmade morphologies are sporadically attested (nos 654, 684). The manufacture is medium, related to the common ware ceramic horizon. The incidence of the type is high (around 2.5% of bowls). Moreover, close similarities are visible with variant *b* of type 2B.4. More general connections are evident with types 2A.3, 2B.3, 2B.7c, and with some specimens of groups 2B.8, 2B9 and 2C.2, which shares similar body shapes associated with thickened rims.

2B.4b – (nos 266-273) – *Bowl, carinated. Inturned upper sides. Elongated upper section.* The group includes open rim sherds with discontinuous profile. The morphology is close to that of variant 2B.4a, distinguished on the basis of the more elongated upper section. A rather sharp discontinuity is, in fact, located around the intermediate or upper portion of the walls. The lower section, not always preserved, is open or almost vertical, with either straight or slightly curved profile. The upper section, relatively long, is inturned, with either straight or curved profile. The rim is plain: coherent with the orientation of the vessel upper sides and simple, with rounded or inside bevelled profile. As with type 2B.4a, the morphology is frequently associated with triangular lugs. The bowls usually have a large mouth and rather thin walls. The type is wheelmade and is mainly found in red slip ware, although related morphologies are occasionally found also in other wares, such as plain (no. 273) or yellow slip ware. Although some finer examples have been observed, the manufacture is mainly medium, related to the common ware ceramic horizon. The incidence of the group is intermediate (around 1% of bowls), but similarities are visible with type 2B.4a, more generally with types 2B.3 and 2B.7c, and with some specimens of groups 2B.8, 2B9 and 2C.2, which share similar body shapes associated with thickened rims.

2B.5 – (nos 274-284, 652) – *Bowl, carinated. Upper convex sides.* The group includes open rim sherds related to bowls with discontinuous profile and upper convex sides. Three main variants have been distinguished: a) simple, b) with markedly inturned upper sides and c) with slight thickening of the inner side of the rim. The incidence of the group is one of the highest among bowls, representing around 6.5% of the inventory. The vast majority of the samples belongs to variant *b*. The cluster, in fact, comprises a large number of rim sherds whose state of preservation prevents a more precise categorization than that of generic upper convex sides small bowls. The incidence of variant *a*, instead, is intermediate, while variant *c* is only sporadic. The type is primarily found in simple (plain and drab ware) and red slip ware, although brown burnished, yellow slip and grey ware samples are also attested. The type is mainly wheelmade, with medium or medium-fine manufacture. It is chiefly to be related to the common ware ceramic horizon, but a fine ware ceramic horizon is also likely in some cases.

2B.5a – (nos 274-278, 652) – *Bowl, carinated. Upper convex sides. Simple.* The group comprises different variants of open rim sherds with discontinuous profile. The discontinuity is located around the intermediate or the upper portion of the walls. The lower section is either straight or curved,

usually almost vertical. The upper section is inturned, with curved profile. The rim is plain: coherent with the orientation of the vessel upper walls and simple, with rounded profile. A horizontal handle may be located on the very upper section of the body (no. 277). The sizes of the bowl range from medium-small to medium. The type is commonly found both in plain and red slip ware, but other wares are also sparsely attested, such as painted, brown burnished and yellow slip ware. It is mainly wheelmade, but a related morphological variant has also been found in plain, handmade ware (no. 652). Although some finer sample are attested, the manufacture is usually medium, related to the common ware ceramic horizon. The incidence of the group is intermediate (around 1.5% of bowls).

2B.5b – (nos 279-281, 283-284) – *Bowl, carinated. Upper convex sides. Markedly inturned.* The group includes different variants of open rim sherds with discontinuous profile that are characterized by markedly inturned upper sides and simple rim. There are a large number of rim sherds whose state of preservation prevents a more precise categorization, and may therefore be considered as a generic cluster. Its range of occurrence, in fact, is among the highest of the family of bowls, representing alone around 5% of the inventory. The discontinuity point, relatively gentle, is mainly located on the upper portion of the wall. The lower section is usually poorly preserved, while the upper section is markedly inturned, with curved profile. The rim is plain: coherent with the orientation of the vessel upper sides and simple, with rounded or pointed profile. The sizes of the bowl are usually small, with medium and medium-small rim diameters and medium-thin/thin walls. The type is found primarily in simple wares (plain and drab ware) and red slip ware, but other wares are also attested, such as brown burnished, yellow slip and grey wares. It is wheelmade, with largely medium manufacture, although finer examples are also registered, relating either to the common or to the fine ware ceramic horizon. Morphological similarities are visible with types 1J.1, 2A.2, 2A.3, 2A.4c, 2B.3 and 2B.5c.

2B.5c – (no. 283) – *Bowl, carinated. Upper convex sides. Inside thickened rim.* This category consists of a single, rim sherd of an upper convex sides bowls distinguished from variant 2B.5b on the basis of the slightly thickened rim. It is in wheelmade red slip ware. The manufacture is overall fine, but the shape is more likely to be related to the common ware ceramic horizon.

2B.6 – (nos 285-288) – *Bowl, carinated. Ribbed rim.* The category includes open rim sherds with discontinuous profile. A discontinuity, more or less sharp, is located on the upper portion of the walls, marked by an extended ledge on the outer side. The lower section, when preserved, is open and straight; the short, upper section is markedly inturned. The rim is composite: coherent with the orientation of the vessel upper sides and outside thickened, with ribbed profile. The sizes of the bowl are medium, with medium or medium-large rim diameters and medium-thick walls. It is exclusively a simple ware type, wheelmade, with medium manufacture, related to the common ware ceramic horizon. The incidence of the type is not substantial.

2B.7 – (nos 289-296) – *Bowl, carinated. Upper convex sides and outside thickened rim.* The category includes different variant of bowls characterized by upper convex sides, mainly inturned, and outside thickened rim. Three main typologies have been identified: a) with vertical upper section, b) with inturned upper section, and c) with markedly inturned upper section. Both small (variant a-b) and medium-large examples (variant c) have been found. It is primarily a red slip ware type, but some plain ware examples are also attested. The type is wheelmade, with medium manufacture, close to the common ware ceramic horizon. The group has a high incidence among bowls: it corresponds to about 4% of the bowls inventory, maintaining some value also among the totality of types (around 2%). Variants a and c both have a relatively high incidence, while variant b is not substantial.

2B.7a – (nos 289-290) – *Bowl, carinated. Upper convex sides and outside thickened rim. Vertical upper section.* The group includes open rim sherds with almost discontinuous profile. A relatively gentle discontinuity is located around the upper portion of the walls. The upper section is almost vertically oriented, with markedly curved profile. The rim is composite: either coherent with the orientation of the vessel upper sides and outside thickened, or everted. The sizes of the bowl are medium-small, with medium rim diameters and thin or medium-thin walls. It is mainly a red slip ware type, but some related samples in plain ware are also attested. It is wheelmade, with medium manufacturing, related to the common ware ceramic horizon. The range of occurrence is relatively high (more than 1.5% of bowls), and similarities are clearly visible with types 2B.7b and 2B.8.

2B.7b – (nos 291-292) – *Bowl, carinated. Upper convex sides and outside thickened rim. Inturned upper section.* The category comprises a sparse group of open rim sherds with discontinuous profile and thin walls, distinguished from variant 2B.7a on the basis of the profile of the upper portion of the sides, which is more clearly inturned, and the specific profile of the rim, flattened and slightly elon-

gated. The state of preservation of the recovered samples is limited to the sole upper section, which is inturned, with almost curved profile. The rim is composite: either coherent with the orientation of the vessel upper sides and outside thickened, or everted. The sizes of the bowl are medium-small, with medium-small rim diameters and thin walls. It is mainly a red slip ware type, wheelmade, with medium-fine manufacture, related to either the common or the fine ware ceramic horizon. The incidence of the type is not substantial.

2B.7c – (nos 293-296) – *Bowl, carinated. Upper convex sides and outside thickened rim. Markedly inturned upper section.* The group includes open rim sherds with discontinuous profile. A rather sharp discontinuity is located on the upper portion of the walls. The lower section is almost vertical; the upper section, usually short, is markedly inturned, with either curved or straight profile. The rim is composite: coherent with the orientation of the vessel upper walls and outside thickened, with slightly elongated and flattened profile. The sizes of the bowl are medium-large, with high variability of rim diameters and medium-thick walls. It is mainly a red slip ware morphology, but related types in plain ware are also attested. It is wheelmade, with medium or medium-fine manufacture, relating to the common ware ceramic horizon. The group has a high frequency among bowls (around 2%), and clear similarities are visible with types 2B.4a-b.

2B.8 – (nos 297-300) – *Bowl, carinated. Upper convex sides and outside thickened, pointed rim.* The group includes medium size open rim sherds with discontinuous profile. A sharp discontinuity is located on the intermediate portion of the walls. The lower section is rarely preserved. The upper section is either vertical or, more frequently, inturned, with curved profile. The rim is composite: coherent with the orientation of the vessel walls and outside thickened, with downside bended profile. The sizes of the bowl vary from medium-small to medium-large, with high variability of rim diameters and medium-thick walls. It is mainly a red slip ware type, although similar morphologies in plain ware are also attested. It is wheelmade, with medium or medium-fine manufacture, close to the common ware ceramic horizon. The frequency of the specific type is relatively low, but similarities can be seen with types 2B.4a-b and 2B.7a.

2B.9 – (nos 301-302) – *Bowl, carinated. Thin walls, inturned upper sides.* The group includes open rim sherds with discontinuous profile. A sharp discontinuity is located approximately on the intermediate portion of the vessel walls. The lower section is open and straight; the upper section, relatively extended, is rather inturned, with straight profile. The rim is composite: either outside thickened or simple and everted. The sizes of the bowl are medium-small, with medium or small rim diameters and thin walls. It is primarily a red slip ware type, but related morphologies in plain ware are also occasionally found. It is wheelmade, with medium-fine manufacture, related to the common ware ceramic horizon. The incidence of the type is not substantial, although some similarity can be seen with types 2B.4a-b, 2B.10 and 2B.11a-b.

2B.10 – (no. 303) – *Bowl, carinated. Thin walls, short, inturned upper sides and thickened rim.* The group comprises sparse open rim sherds with discontinuous profile. A sharp discontinuity is located approximately on the upper portion of the vessel walls. The lower section is rarely preserved; the short, upper section is inturned, with straight profile. The rim is composite: coherent with the orientation of the vessel sides and outside thickened, with rounded profile. The sizes of the bowl are medium, with variable rim diameters and medium-thick walls. It is primarily a red slip ware type. It is wheelmade, with medium-fine manufacture, related to the common ware ceramic horizon. The incidence of the type is not substantial, but there are similarities with type 2B.9.

2B.11 – (nos 304-305) – *Bowl, carinated. Thin walls, inturned upper sides and tapered rim.* The category includes open rim sherds related to thin, carinated bowls with inturned upper sides and outside thickened, tapered rim. Two main variants have been identified: a) with outside thickened rim, and b) with outside and inside thickened rim. The majority of the recovered examples belong to variant a, but the incidence of the type is not substantial. It is almost exclusively a red slip ware type. It is wheelmade, with medium manufacture, related to the common ware ceramic horizon.

2B.11a – (no. 304) – *Bowl, carinated. Thin walls, inturned upper sides and tapered rim. Outside thickened rim.* The group includes a few open rim sherds with discontinuous profile. A markedly sharp discontinuity is located on the intermediate section of the vessel wall. The lower section is barely preserved; the upper section is inturned, with straight profile. The rim is composite, either coherent with the orientation of the vessel walls and outside thickened or simple and everted. The sizes of the bowl are medium-small, with intermediate rim diameters and thin walls. It is almost exclusively a red slip ware type. It is wheelmade, with medium manufacture, related to the common ware ceramic horizon. Some similarity can be seen with type 2B.9.

2B.11b – (no. 305) – *Bowl, carinated. Thin walls, inturned upper sides and tapered rim. Outside and inside thickened rim.* This category comprises a single, sporadic rim sherd related to a thin, carinated bowl with upper inturned sides that is distinguished from type 2B.11a on the basis of the rim typology. The rim, in fact, is thickened on both the outside and inside. It is in wheelmade, red slip ware, with medium manufacture, to be related to either the fine or the common ware ceramic horizon.

2B.12 – (nos 306-309) – *Bowl, carinated. Short, vertical upper sides and thickened rim.* The category includes open rim sherds related to carinated bowls with vertical upper sides and variously thickened rim. It includes two main variants: a) with outside thickened, ledged rim, and b) with outside and inside thickened rim. The type is wheelmade: the second variant is mainly a brown burnished ware morphology, while the first variant is found in different wares, such as yellow slip, grey and red slip ware. The manufacture is medium or fine, close to the common ware ceramic horizon. The incidence of the type is not substantial.

2B.12a – (nos 306-307) – *Bowl, carinated. Short, vertical upper sides and thickened rim. Outside thickened, ledged rim.* The group includes sparse open rim sherds with vertical upper sides and outside thickened, ledged rim. The profile is discontinuous. A more or less sharp discontinuity point is located on the upper portion of the vessel sides. The lower section is barely preserved, while the short, upper section is vertically oriented, with straight profile. The rim is composite: coherent with the orientation of the vessel walls and outside thickened, forming a sort of ledge. The profile of the rim is either squared or rounded. The sizes of the bowl vary from medium-small (no. 306) to medium-large (no. 307), with variable rim diameters and medium thickness of the wall. Related morphologies are found in wheelmade grey, yellow slip and red slip ware. The manufacture varies from medium-fine to medium coarse, overall to be related to the common ware ceramic horizon. Some minor similarities may be seen with types 2A.23 and 2A.29b.

2B.12b – (nos 308-309) – *Bowl, carinated. Short, vertical upper sides and thickened rim. Outside and inside thickened rim.* The category includes sporadic open rim sherds with discontinuous profile. A sharp discontinuity point is located on the upper portion of the vessel sides: the lower section is open and straight; the short, upper section is vertically oriented, with straight profile. It is distinguished from variant 2B.12a on the basis of the rim typology, which is variously outside and inside thickened, with horizontal upper profile. The sizes of the bowl are medium, with intermediate rim diameters and medium-thick walls. The morphology, which is wheelmade, with medium manufacture, is typical of brown burnished ware, relating to the common ware ceramic horizon.

2B.13 – (no. 310) – *Bowl, carinated. Inturned upper sides and everted rim.* The category relates to a single open rim sherd with discontinuous profile. The discontinuity is located on the intermediate portion of the vessel wall: the lower section, almost vertical, is barely preserved, while the upper section is markedly inturned, with straight profile. The rim is composite, everted, simple, with outer side squared profile. The size of the bowl is medium-large, with medium-large rim diameter and medium-thick walls. It is in wheelmade, plain ware, with medium manufacture and related to the common ware ceramic horizon. A certain similarity with type 2B.18 can be noted.

2B.14 – (nos 311-314) – *Bowl, carinated. Everted upper sides and thickened rim.* The category includes different variants of various size rim sherds related to carinated bowls with everted upper sides and thickened rim. A sharp discontinuity is located around the intermediate portion of the vessel walls: the lower section, rarely preserved, is open, while the upper section is markedly everted, with slightly concave profile. The rim is composite: almost coherent with the orientation of the vessel sides and outside thickened, with various profile. The sizes vary greatly, ranging from medium-small to large. The general morphology is attested in different wares, such as plain, red slip, brown burnished and coarse grained ware. It is wheelmade, with medium manufacture, related to the common ware ceramic horizon. The incidence of the type is not substantial, but some similarity may be noted with types 2B.15a-b.

2B.15 – (nos 315-321) – *Bowl, carinated. Short, vertical upper sides and outside thickened rim.* The category includes open rim sherds related to carinated bowls with short upper sides with vertical profile. Two main variants have been identified: a) with straight upper section, and b) with concave upper section. It is mainly a simple and a red slip ware type, but other wares are also attested. It is wheelmade, with medium manufacture, related to the common ware ceramic horizon. The frequency of the group among bowls is medium-high (around 1.5%).

2B.15a – (nos 315-316) – *Bowl, carinated. Short, vertical upper sides and outside thickened rim. Straight upper sides.* The group includes open rim sherds with discontinuous profile. A sharp discontinuity is located on the upper portion of the vessel sides. The lower section, when preserved, is open

and straight; the short, upper section is vertically oriented, with straight profile. The rim is composite: coherent with the orientation of the vessel sides and outside thickened, with rounded or pointed profile. The sizes of the bowl vary from medium-small to medium-large, with variable rim diameters and intermediate thickness of the walls. It is mainly a simple ware type, but related morphologies are found also in red slip and brown burnished ware. It is wheelmade, with medium manufacture, related to the common ware ceramic horizon. The incidence of the group is rather low (less than 1% of bowls), but there are clear similarities with the variant *b* of type 2B.15 and with type 2B.14.

2B.15b – (nos 317-321) – *Bowl, carinated. Short, vertical upper sides and outside thickened rim. Concave upper sides.* The group includes open rim sherds with discontinuous profile. A markedly sharp discontinuity is located on the upper portion of the vessel wall: the lower section is poorly preserved, while the short, upper section is vertically oriented, with concave profile. The rim is composite, either coherent with the orientation of the vessel walls or simple and slightly everted. The sizes of the bowl are medium, with medium or medium-large rim diameters and medium thickness of the walls. It is mainly a plain and red slip ware morphology. It is wheelmade, with medium or medium-fine manufacture, related to the common ware ceramic horizon. The frequency of the type is low (less than 1% of bowls), but there are similarities with types 2B.1, 2B.14, 2B.15a, 2B.16 and some variants of 2B.18.

2B.16 – (nos 322-323) – *Bowl, carinated. Vertical upper sides, tapered rim and marked carination.* The category includes open rim sherds with discontinuous profile. A sharp discontinuity, upper side markedly highlighted, is located on the upper portion of the vessel wall. The poorly preserved lower section is almost vertical, while the upper section is vertically oriented, with concave profile. The rim is composite: coherent with the orientation of the vessel walls and outside thickened, with tapered profile. The sizes of the bowl are medium-large, with medium-large rim diameters and medium-thick walls. The state of preservation of the recovered sherds prevents any solid evaluation, but the orientation of the sides might relate to both normal and deep bowls. It is almost exclusively a simple ware morphology. It is wheelmade, with medium manufacture, related to the common ware ceramic horizon. The incidence of the type, which is fairly specific, is rather low, but there are similarities with types 2B.15b, 2B.17 and 2B.18.

2B.17 – (nos 324-325) – *Bowl, carinated. Rounded rim and marked carination.* The group includes sparse, open rim sherds with discontinuous profile. A sharp discontinuity, marked outer side by a small rib, is located on the upper portion of the vessel wall: the lower section, when preserved, is straight, while the upper section is either vertical or feebly inturned, with slight concave profile. The rim is composite: coherent with the orientation of the vessel sides and outside thickened, with rounded profile. The bowls are medium-large, with medium-large and large rim diameters and medium-thick walls. It is predominantly a simple ware morphology, wheelmade, with medium manufacture, related to the common ware ceramic horizon. The incidence of the type is not substantial, but similarities can be seen with types 2B.16 and 2B.18.

2B.18 – (nos 326-335) – *Bowl, carinated. Inturned upper sides and outside thickened rim.* The category includes different variants of open rim sherds with markedly discontinuous profile. A sharp discontinuity is located either on the upper or on the intermediate portion of the vessel walls. The lower section is straight, open or almost vertical, while the upper section is noticeably inturned. The upper section profile is usually straight, but slightly concave examples have also been grouped in the same family. The rim is composite: it is usually coherent with the orientation of the vessel walls and outside thickened, but simple, everted rims (see no. 327) are also attested. The sizes of the bowl are medium-large and large, with medium-large rim diameters and medium-thick walls. It is almost exclusively a simple ware morphology, wheelmade, with medium manufacture, related to the common ware ceramic horizon. The type is rather frequent among bowls (around 2% of the bowls inventory) and it shows similarities to types 2B.13, 2B.15b, 2B.16 and 2B.17.

2C – (nos 336-343, 658-661) – *Bowl, deep.* The category includes almost open rim sherds which, despite the poor state of preservation, are probably to be related to deep bowls. Three main variants and two lesser variants have been identified for a total of four bowl types. A group of rim sherds whose state of preservation was limited to the sole upper section has been assigned to the general category of deep bowls (see no. 658).

2C.1 – (nos 336-339) – *Bowl, deep. Almost vertical sides.* The category includes almost vertical sided rim sherds most probably to be related to deep bowls. Two main variants have been identified: a) with squared rim, and b) with rounded rim. The morphology is most commonly found in wheelmade, plain ware, but yellow slip and red slip ware samples are also attested. The manufacture is

medium, related to the common ware ceramic horizon. The incidence of the group is medium-high, although most of the examples belong to variant *b*.

2C.1a – (nos 338-339) – *Bowl, deep. Almost vertical sides. Squared rim.* The group includes almost vertical rim sherds with curved profile. Their state of preservation is usually limited to the sole upper portion of the vessel. The rim is composite: coherent with the orientation of the vessel walls and outside thickened, forming a sort of ledge with rather squared profile. The sizes of the bowl are large, with large rim diameters and medium-thick/thick walls. It is primarily a yellow slip ware type. It is wheelmade, with medium manufacture, related to the common ware ceramic horizon. The frequency of the group is not substantial.

2C.1b – (nos 336-337) – *Bowl, deep. Almost vertical sides. Rounded rim.* The group comprises almost vertical rim sherds with curved profile more probably to be related to deep bowls. They are distinguished from variant *a* of type 2C.1 on the basis of the rim profile, almost rounded. The sizes of the bowl are large, with medium-large and large rim diameters and medium-thick to thick walls. It is primarily a simple ware morphology, but similar examples are found also in other wares, such as red slip, yellow slip and grey ware. It is wheelmade, with medium manufacture, to be related to the common ware ceramic horizon. The frequency of the type is intermediate.

2C.2 – (nos 340-343) – *Bowl, deep. Upper convex sides and thickened rim.* The group gathers different variants of upper convex sides most probably to be related to deep bowls. The rim is composite: coherent with the orientation of the vessel sides and outside thickened, usually with a rather elongated profile. Horizontal lugs with rounded or triangular profile are frequently found attached to the upper section of the sides. The sizes of the bowl are medium-large, with medium-large rim diameters and medium thickness of the walls. It is primarily a red slip ware type, although related morphologies are also attested in yellow slip ware. It is wheelmade, with medium manufacture, related to the common ware ceramic horizon. The frequency of the group is low, but it shows some similarities with variants 2B.4a and 2B.4b.

2C.x – (nos 659-661) – *Bowl, deep. Sinuous upper sides.* The category includes sparse, handmade, almost vertical rim sherds possibly to be connected with deep bowls, and characterised by sinuous upper sides. The profile of the sides is discontinuous. A gentle discontinuity is located on the very upper portion of the vessel walls. The lower section, where preserved, is almost vertical. The short, upper section, almost coinciding with the rim, is slightly everted or vertical. The rim is simple, with rather squared profile. The sizes of the bowl are probably medium or medium-large: the rim diameters are, in fact, difficult to reconstruct, while the walls are rather thick. It is typically a handmade, plain ware morphology, with medium/medium-coarse manufacture, related to the common ware ceramic horizon.

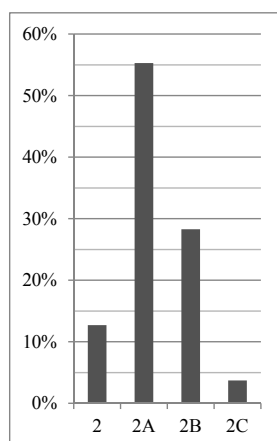


Diagram 9a: Type 2-Bowls. Occurrence of main variants¹⁰⁷ – *Code layout*.

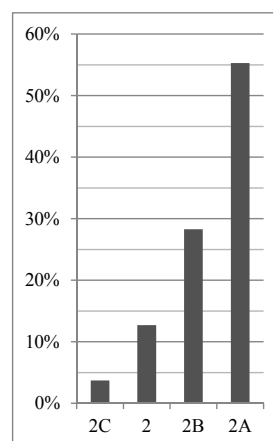


Diagram 9b: Type 2-Bowls. Occurrence of main variants – *Bottom-up layout*

¹⁰⁷ Percentages are calculated on the total of 1784 type 2 diagnostic sherds.

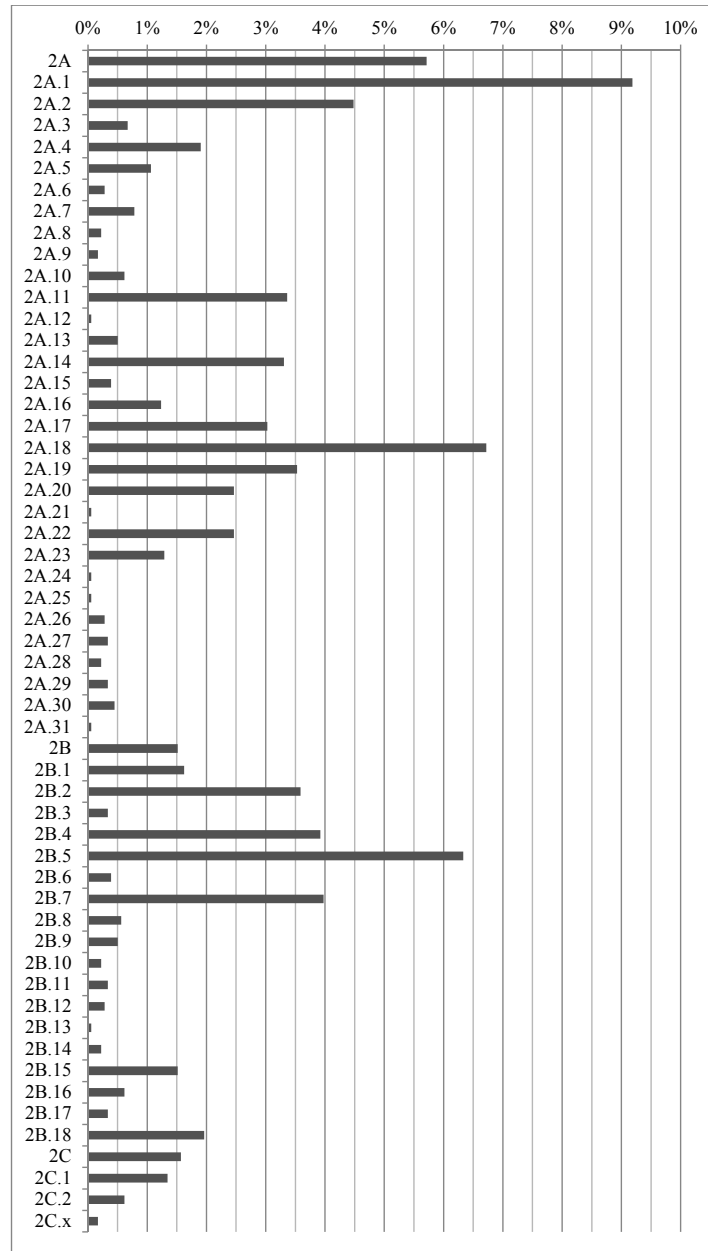


Diagram 10a: Type 2-Bowls. Occurrence of main variants and sub-variants¹⁰⁸ – Code layout.

¹⁰⁸ Percentages are calculated on a total of 1784 type 2 diagnostic sherds.

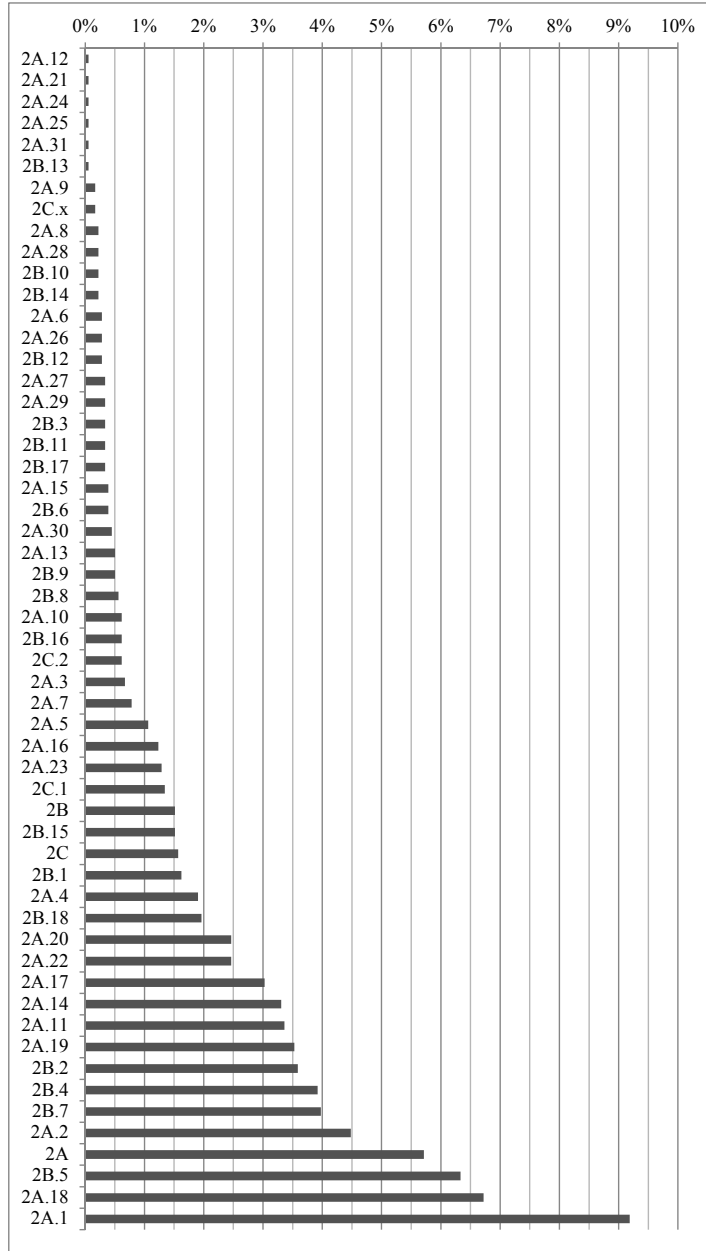


Diagram 10b: Type 2-Bowls. Occurrence of main variants and sub-variants – *Bottom-up layout*.

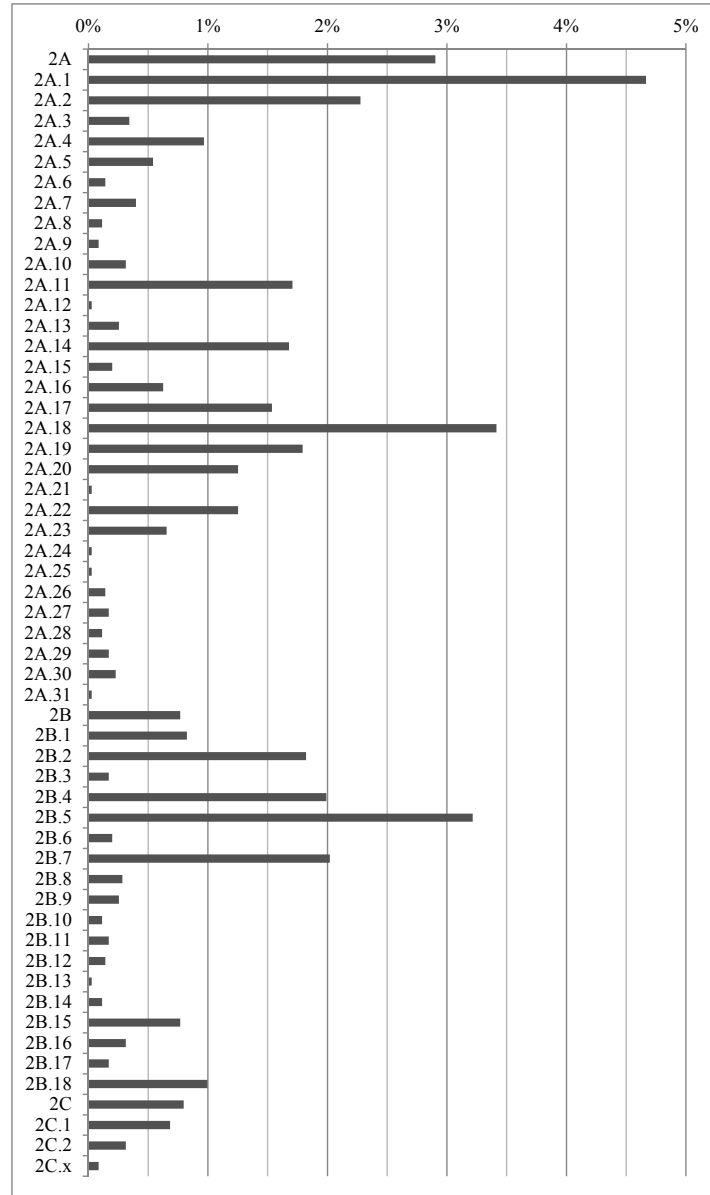


Diagram 11a: Type 2-Bowls. Occurrence of main variants and sub-variants on the inventory of main shapes¹⁰⁹ – Code layout.

¹⁰⁹ Excluded from representations on the graphs are those sherds only generally defined as type 2, which accounted for 6% of the inventory. Percentages are calculated on a total of 3514 diagnostic sherds with identified morphology.

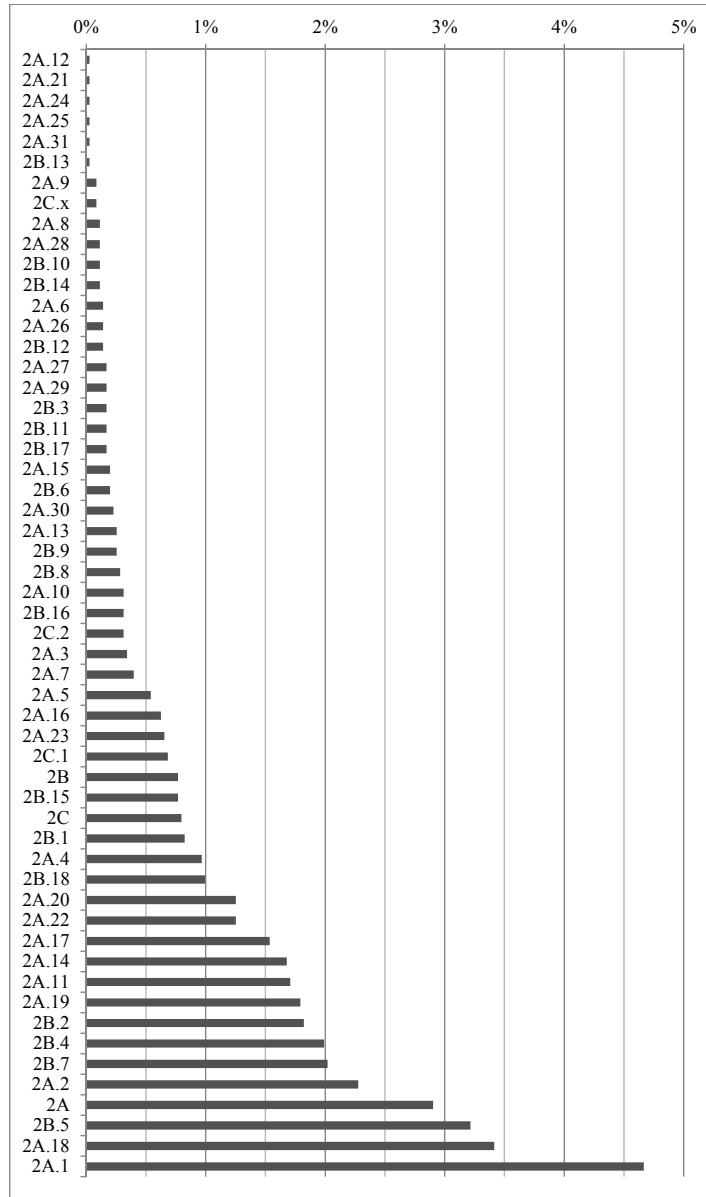


Diagram 11b: Type 2-Bowls. Occurrence of main variants and sub-variants on the inventory of main shapes – *Bottom-up layout.*

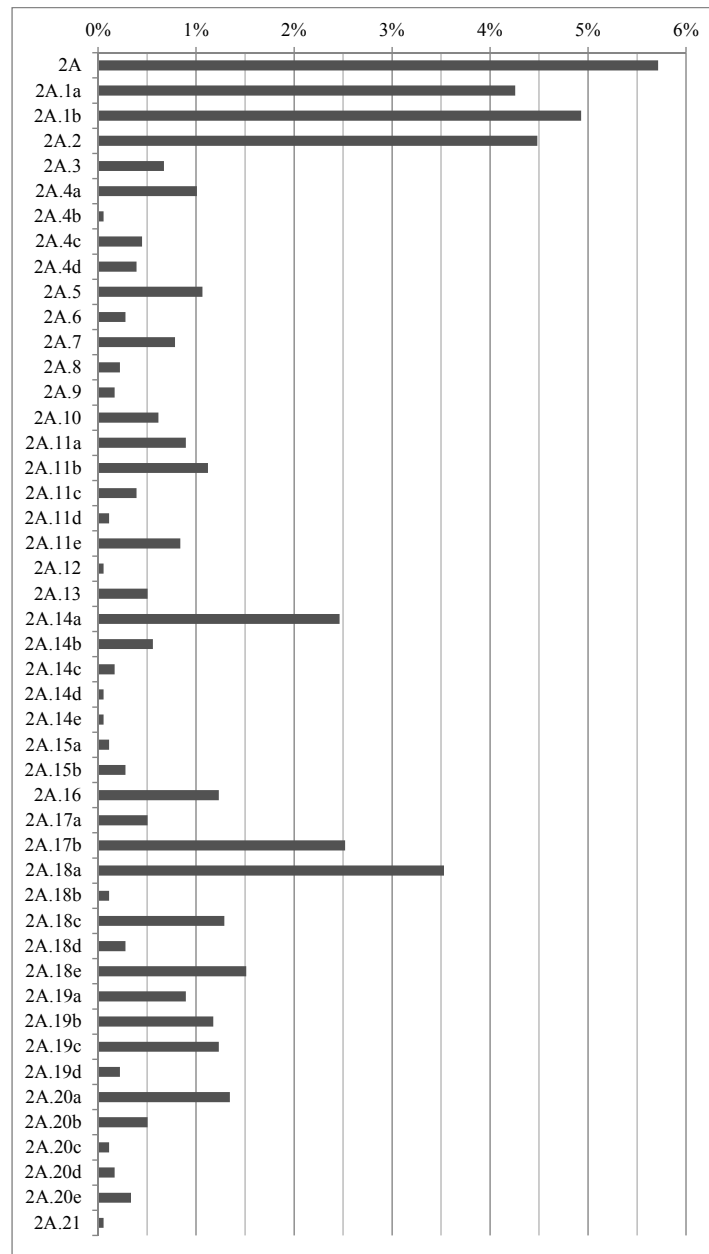


Diagram 12a-Section I: Type 2-Bowls. Occurrence of main variants, sub-variants and lesser variants¹¹⁰ – Code layout (types 2A-2A.21).

¹¹⁰ Percentages are calculated on the total of 1784 type 2 diagnostic sherds.

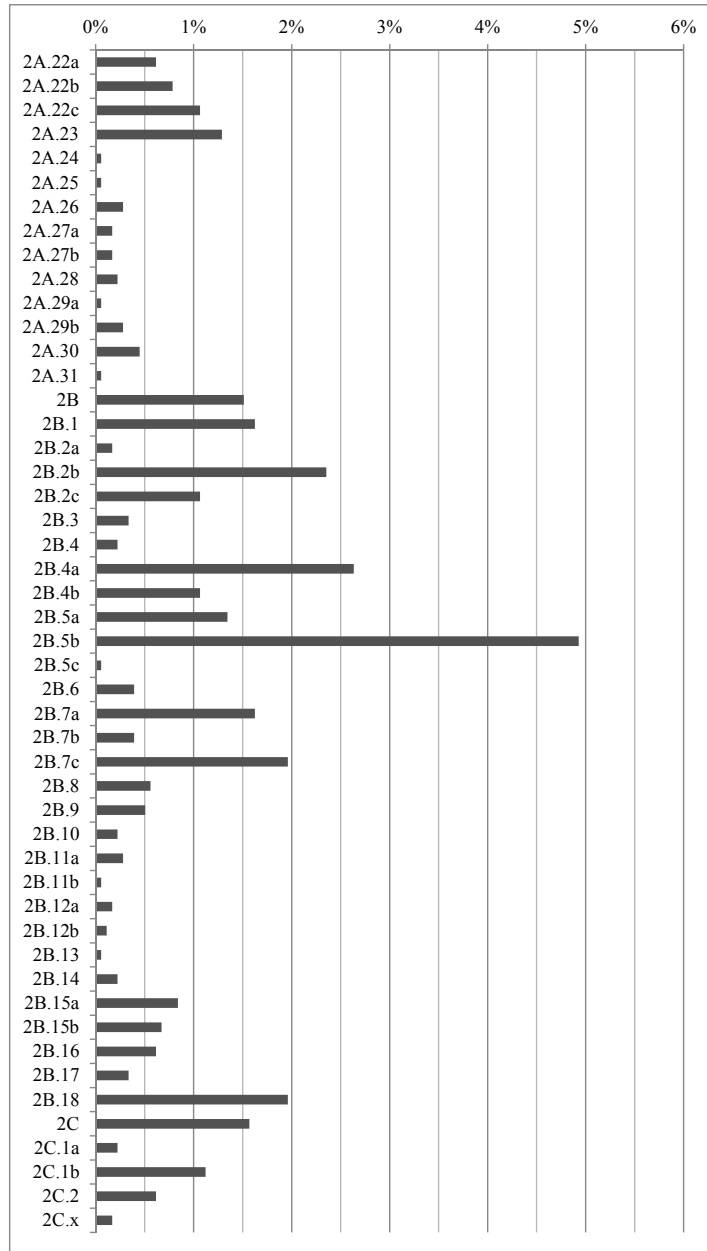


Diagram 12a-Section II: Type 2-Bowls. Occurrence of main variants, sub-variants and lesser variants – *Code layout* (types 2A.22a-2C.x).

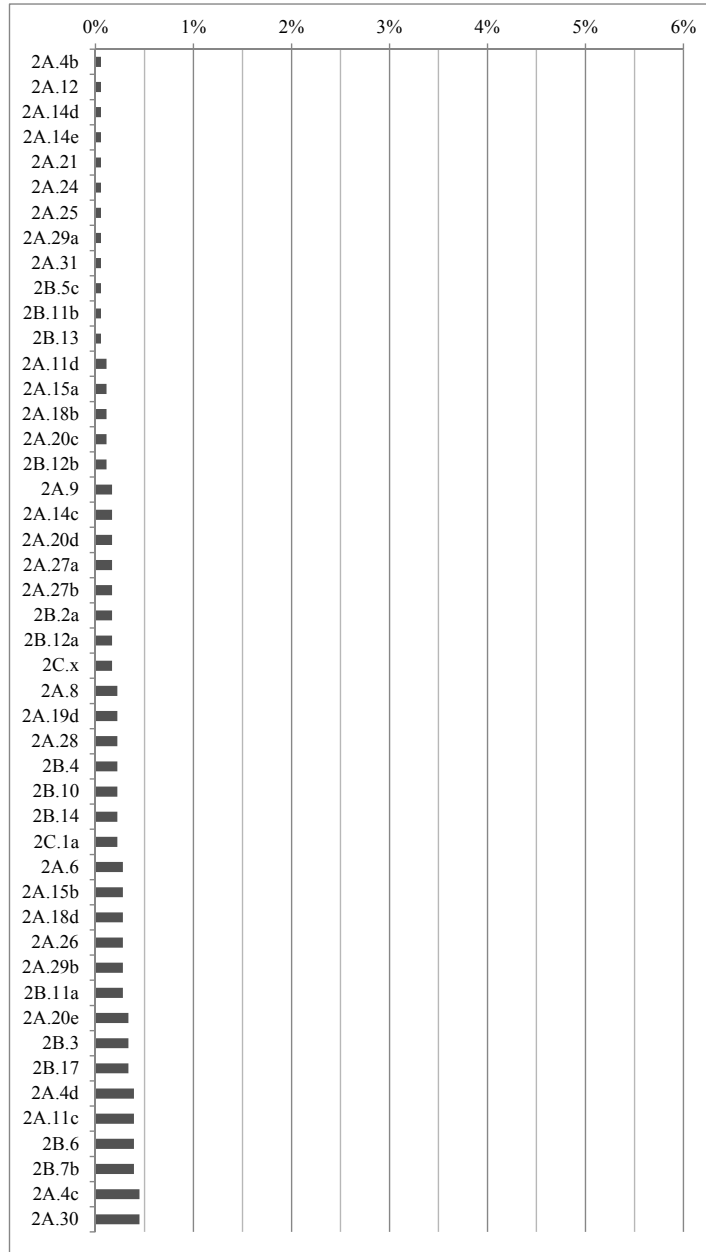


Diagram 12b-Section I: Type 2-Bowls. Occurrence of main variants, sub-variants and lesser variants – *Bottom-up layout* (0-0.45%).

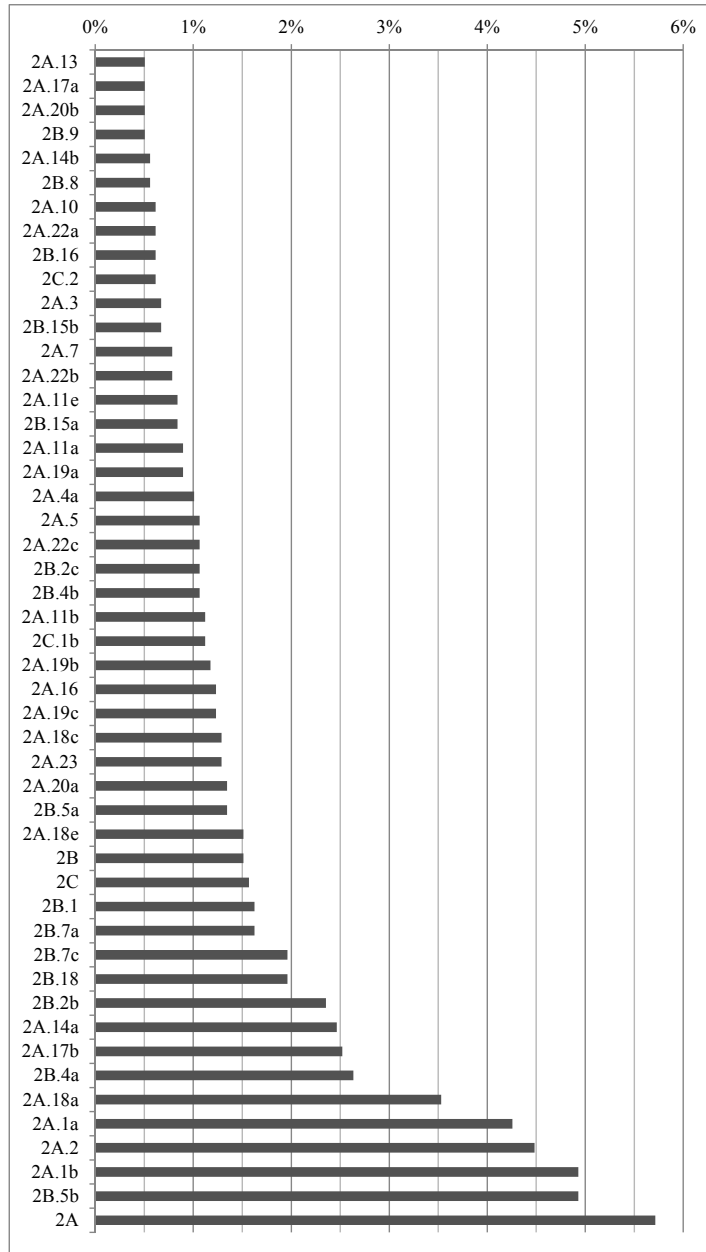


Diagram 12b-Section II: Type 2-Bowls. Occurrence of main variants, sub-variants and lesser variants – Bottom-up layout (0.50-5,71%).

3A – (nos 345-358, 361-363) – *Small Jars*. The category includes almost closed rim sherds, or rim sherds in which the upper portion of the sides is inturned, probably to be related to small jars or cups. They are characterised by thin walls and medium-small rim diameters, ranging from a minimum of 5.5cm (see no. 348) to a maximum of 22cm (no.354). A principal distinction is between neckless or almost neckless examples (variants 1-2), whose morphological features are rather close to those of bowls, and necked samples (variants 3-5), which are closer to closed shapes. Five main variants have been distinguished: 1) with simple, everted rim, 2) with outside thickened rim, 3) with high neck, 4) with thin, high neck and 5) with incised rim. A cluster of poorly preserved rim sherds, instead, has been assigned to the general category of either shape 3 or 3A, according to their different state of preservation. The morphology, overall, is typically found in wheelmade simple and red slip ware, but related samples are found also in other wares, especially brown burnished, painted, yellow slip and kitchen ware. The manufacture varies from fine to medium, indicating that this type is to be related to either the fine or, more frequently, the common ware ceramic horizon. The incidence of the group is overall low, representing about 2.4% of the total shapes inventory.

3A.1 – (nos 345-354) – *Small Jars. Simple, everted rim*. The category includes different variants of either closed rim sherds or rim sherds with upper inturned sides. The junction between shoulder and orifice is gentle. The orifice includes a very short neck with curved or curved and closed profile (nos 345-352) or almost neckless shapes (nos 353-354) with simple, everted rim. The rim has rounded or, more frequently, pointed profile. The sizes are usually small, with medium size average rim diameters and thin walls. It is typically a red slip or plain ware morphology, but other wares are also attested, such as brown burnished, painted and yellow slip ware. It is wheelmade. The manufacture ranges from fine to medium, relating to either the fine or the common ware ceramic horizon. This group comprises the vast majority of the rim sherds belonging to type 3, representing about 60% of the family. Some similarities can be noted with type 3A.2.

3A.2 – (nos 355-357) – *Small Jars. Outside thickened rim*. The group includes closed or upper inturned side sherds probably to be related to neckless small jars with globular or ellipsoid (squat) body. The junction between shoulder and rim is rather sharp. The rim is composite: either coherent with the orientation of the vessel upper walls and outside thickened or simple and everted. The profile of the rim is rounded or pointed. Vertical lugs may be located immediately under the rim. The sizes are rather small, with small rim diameters (around 10cm) and thin walls. It is primarily a plain ware morphology, but similar samples are also found in red slip ware. It is wheelmade, with medium or fine manufacture, to be related either to the fine or to the common ware ceramic horizon. The incidence of the group is rather low (around 6% of type 3), but there is some similarity with type 3A.1.

3A.3 – (no. 358) – *Small Jars. High neck*. The group refers to a single, closed rim sherd with high neck related to a small jar. The profile of the jar is sinuous, the junction between the shoulder and the neck being rather gentle. The shoulder, as far as it is preserved, is curved, almost vertically oriented. The orifice includes a high, curved neck and a composite rim, coherent with the orientation of the neck and slightly thickened outer side, with outside bevelled profile. The sizes are medium-small, with medium-small rim diameters (around 16cm) and medium-thin walls. The type is in kitchen ware, wheelmade, with medium manufacture, related to the kitchen ware ceramic horizon.

3A.4 – (nos 361-362) – *Small Jars. Thin, high neck*. The category includes thin, closed rim sherds whose state of preservation is limited to the orifice. This includes a relatively high neck, almost flaring, and either simple or outside thickened rim. The sizes are rather small, with small rim diameters (around 8.5cm) and thin walls. The type, which is wheelmade, with medium or medium-fine manufacture, is typical of painted ware, and it is related either to the fine or to the common ware ceramic horizon. The frequency of the group among the small jars is not substantial.

3A.5 – (no. 363) – *Small Jars. Incised rim*. The category refers to a single, closed rim sherd whose state of preservation is limited to the sole rim. It is likely to be related to a small jar with straight, open neck. The rim is outside thickened, vertically oriented, with incised decoration on the rim profile. The size is medium-small, with medium-small rim diameter and thin walls. It is in red slip ware, wheelmade, with medium-fine manufacture, mainly related to the fine ware ceramic horizon.

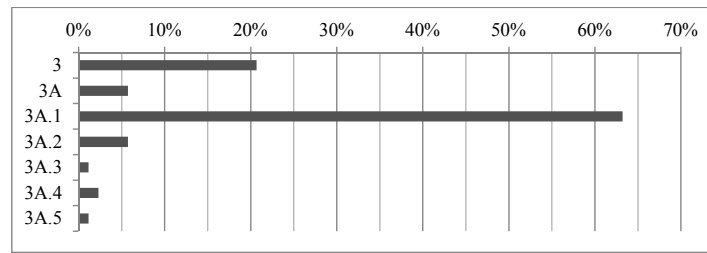


Diagram 13a: Type 3-Goblets and Small Jars. Occurrence of main variants¹¹¹ – *Code layout*.

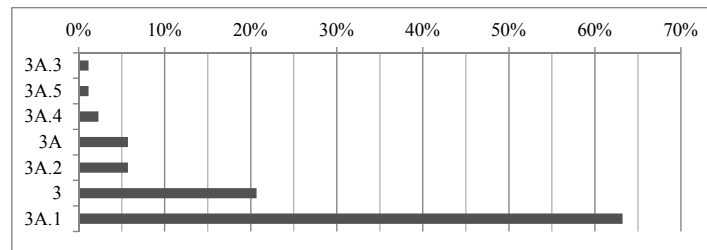


Diagram 13b: Type 3-Goblets and Small Jars. Occurrence of main variants – *Bottom up layout*.

5A – (nos 364-397, 662-666) – *Neckless Jars*. This category includes closed rim sherds probably to be related to pots and neckless jars. Sizes usually vary from medium-small to medium-large, but particularly small examples have also been found that belong to the same morphological family (see type 5A.12). Twelve main variants have been identified plus two lesser variants, for a total amount of thirteen categories. Given the poor state of preservation, instead, a cluster of rim sherds has been assigned to the general category of either shape 5 or 5A. Among better preserved samples, variant 3, which is characterized by outside thickened and flattened rim, is by far the most common (around 41% of type 5 inventory), followed by variant 1, with simple rim, and 6, with outside thickened and tapered rim (each around 12% of type 5 inventory). Major distinguishing factors are the morphology of the rim and, as far as they are preserved, the orientation of the shoulder, which may provide some indications concerning the general morphology of the bodies. Most of the recovered neckless jars are in kitchen ware (around 62%), while a lesser number belong to the plain ware (23%). Related morphologies, however, have been found also in red slip ware (9%). The vast majority of the examples is wheelmade, with medium or medium-coarse manufacture, related to either the kitchen or the common ware ceramic horizon. A small inventory of poorly preserved rim sherds, instead, is handmade (nos 662-666) either in plain (nos 663-664) or red slip ware (nos 662, 665-666). They are characterized by simple rim, with rounded or inside bevelled profile, and different sizes, which vary from small (no. 663) to large (no. 666). The incidence of the neckless jars among the inventory of shapes is rather limited, corresponding to about 9% of the totality. Nevertheless, after bowls and necked jars, neckless jars are the 3rd cluster in order of attestation.

5A.1– (nos 364-365, 662-666) – *Neckless Jar. Simple rim*. The category includes closed rim sherds with curved shoulder and no neck. The rim is either in continuity with the vessel shoulder (no. 364) or slightly deviated, vertically oriented (no. 365). The profile is simple, usually inside bevelled. The sizes of the vessel vary from medium to large, with high variability of rim diameters and wall thickness. The type is almost exclusively wheelmade. It is primarily found in kitchen ware, related to the kitchen ware ceramic horizon, but related morphologies are also occasionally found in other wares

¹¹¹ Percentages are calculated on the total of 87 type 3 diagnostic sherds.

such as plain and red slip ware, most probably to be related to the common ware ceramic horizon. The manufacture, in fact, is mainly medium or medium-coarse. Among shape 5 examples, the incidence of the group is medium high. Moreover, some similarities can be noted with type 5A.2.

5A.2 – (nos 366-369) – *Neckless Jar. Outside thickened, rounded rim*. The group comprises sparse closed rim sherds with either curved or nearly straight shoulders, almost vertically or intermediately oriented. The rim is composite, either coherent with the orientation of the vessel upper section and outside slightly thickened (nos 366-368) or deviated, vertically oriented and simple (no. 369). Vertical lugs are sometimes attested attached immediately under the lip. The sizes are medium, usually with large rim diameters and medium-thick walls. The type is found in both kitchen and simple ware, although similar morphologies are also attested in painted ware. It is wheelmade, with medium or medium-coarse manufacturing, related to the kitchen or the common ware ceramic horizon. Some morphological similarities may be noted with types 5A.1 and 5A.3.

5A.3 – (nos 370-373) – *Neckless Jar. Outside thickened, flattened rim*. The group includes closed rim sherds with curved shoulder whose inclination ranges from almost vertical to nearly horizontal. The rim is composite: coherent with the orientation of the vessel walls and outside thickened. The profile of the rim is slightly elongated, with rounded upper side and lower side sharpened. The sizes range from medium to large, with high variability of rim diameters and medium-thick to thick walls. It is mainly a kitchen ware morphology, related to the kitchen ware ceramic horizon. Comparable morphologies are well attested in simple ware, while red slip ware varieties are sparse. They are wheelmade, with medium or medium-coarse manufacture, mainly to be related to the common ware ceramic horizon. The incidence of the type is very high, covering the vast majority of type 5 examples. Similarities can be seen especially with variants 5A.2 and 4A.4.

5A.4 – (nos 374-375) – *Neckless Jar. Outside thickened, sharpened rim*. The category includes sparse, closed rim sherds related to large mouthed neckless jars and characterised by outside thickened rim. The shoulder may be either curved, with intermediate inclination (no. 374), or rather straight, almost vertically oriented (no. 375). The rim is composite: coherent with the orientation of the vessel upper section and outside thickened, slightly elongated, sharpened lower side. The sizes are medium-large, with large rim diameters and medium-thick to thick walls. It is a typical kitchen ware type, wheelmade, with medium manufacture, related to the kitchen ware ceramic horizon. There is some morphological similarity with type 5A.3.

5A.5 – (nos 376-377) – *Neckless Jar. Everted rim*. The group comprises different variants of medium size closed rim sherds related to neckless jars with everted rim. The shoulder, usually rather upraised, is curved. The rim is composite, almost simple and everted, usually inside bevelled. The sizes are medium, with intermediate rim diameters (around 16-20cm) and medium thickness of the walls. It is mainly a kitchen and a plain ware morphology, wheelmade, with medium or, especially in case of the kitchen ware sample, medium-coarse manufacture, related to either the kitchen or the common ware ceramic horizon. The incidence of the group among neckless jars is medium/medium-low, but there are similarities with some short necked jars morphologies such as type 6A.1a and, despite the difference in size, with type 8A.1.

5A.6 – (nos 378-381) – *Neckless Jar. Outside thickened, tapered rim*. The group includes poorly preserved, medium size, closed rim sherds that are characterized by outside thickened, tapered rim. The state of preservation of the samples is limited to the very upper portion of the vessel. The shoulders, as far as they are preserved, are curved, almost upraised. The rim is composite, mainly coherent with the orientation of the vessel upper walls and outside thickened. The profile is typically curved on the upper side and tapered on the outer side. The sizes of the jar are medium, with intermediate rim diameters and medium thickness of the walls. It is mainly a kitchen ware type, but similar samples are attested also in plain ware, while other wares, such as red slip and yellow slip ware, are sporadic. The incidence of the group among the neckless jars is medium high.

5A.7 – (nos 382-384) – *Neckless Jar. Outside thickened, slightly ridged rim*. The category includes closed rim sherds characterised by outside thickened and lightly ribbed rim. The shoulder is curved, with intermediate inclination. The rim is composite: coherent with the orientation of the vessel upper walls and outside thickened. The profile of the rim is markedly rounded on the upper side and sharpened on the outer side, with typical, small ridges on the outer, lower side. The sizes of the jar are medium-large, with medium-large rim diameters and medium to medium-thick walls. It is almost exclusively a kitchen ware morphology, wheelmade, with medium or coarse manufacture, related to the kitchen ware ceramic horizon. The incidence of the group is not substantial.

5A.8 – (nos 385-389) – *Neckless Jar. Grooved under rim.* The category includes different variants of closed rim sherds characterized by the presence of a large groove under the rim and/or a rib on the shoulder. Two main types have been distinguished based on average vessels sizes: a) with thick walls, more commonly found in kitchen ware, and b) with thin walls and larger mouth, more typically found in red slip ware. The type is wheelmade, with medium manufacture, to be related either to the kitchen or to the common ware ceramic horizon. The incidence of the category is overall medium-low.

5A.8a – (nos 385-386) – *Neckless Jar. Grooved under rim. Thick walls.* The group includes closed rim sherds related to neckless jars. The shoulder is either curved or straight, with almost intermediate inclination. The rim is composite: coherent with orientation of the vessel upper sides and outside thickened, with slightly pointed profile. The presence of a large groove under the rim is typical and may be associated with a thickened, sharpened rib. The sizes are intermediate, with medium or medium-small rim diameters and medium-thick to thick walls. Despite the attestation of sporadic other wares, it is mainly a kitchen ware morphology, wheelmade, with medium manufacture, related to the kitchen ware ceramic horizon. The incidence of the group is relatively low.

5A.8b – (nos 387-389) – *Neckless Jar. Grooved under rim. Thin walls.* The group comprises almost closed rim sherds related to large mouthed vessels with curved shoulders. The inclination of the shoulders ranges from almost horizontal (no. 387) to intermediate. The rim is composite: coherent with the orientation of the vessel upper sides and outside thickened. As with variant 5A.8a, the type is characterised by the presence of a large groove under the rim, delimited by a thickened rib. The sizes are intermediate, with large rim diameters and medium-thin walls. It is a typical red slip ware morphology, wheelmade, with almost medium manufacture, related to the common ware ceramic horizon. The frequency of the type among the neckless jars is not substantial.

5A.9 – (nos 390-391) – *Neckless Jar. With upper lug.* The category includes two rim sherds mainly related to neckless jars characterized by the presence, immediately under the rim, of a horizontal lug. One is a small size kitchen ware jar with curved shoulders and plain rim. The second example is a plain ware large mouthed vessel with curved shoulders and ribbed decoration. They are both wheelmade, with medium manufacture, related respectively to the kitchen and to the common ware ceramic horizon.

5A.10 – (nos 392-393) – *Neckless Jar. Thin walls.* The category refers to two sporadic, closed rim sherds. They have curved shoulder with almost intermediate inclination and small, outside thickened rim. The sizes are mainly small, with medium or medium-small rim diameters and thin walls that recalls of bowls morphology. A similar morphology is found both in kitchen ware, characterised by medium manufacture, and in plain ware, characterized by slightly finer manufacture. The examples are both wheelmade, respectively related to the kitchen and to the common ware ceramic horizon.

5A.11 – (nos 394-395) – *Neckless Jar. Outside thickened, grooved rim.* The category includes almost closed rim sherds characterized by wide mouth and outside thickened, ribbed rim. A high variability is registered in the bodies of the vessels, which may have either rounded (no. 395) or almost vertical sides (no. 394). The rim is composite, either coherent with the orientation of the vessel upper walls (no. 395) or everted (no. 394) and outside thickened. The profile of the rim, which is upper side curved, presents a typical, small grooving on the lower, outer side. It is mainly a kitchen ware type, although related morphologies are sporadically attested also in other wares, such as plain and brown burnished ware. The morphology is always wheelmade. The kitchen ware examples are of rather coarse manufacture, and are related to the kitchen ware ceramic horizon. The other examples, instead, are of mainly medium manufacture, and are more likely to be related to the common ware ceramic horizon. The frequency of the group is not substantial.

5A.12 – (nos 396-397) – *Neckless Jar. Small.* The group includes a series of small, poorly preserved rim sherds with outside thickened, sharpened rim. A relatively high variability is registered in rim sizes, which range from small (no. 396) to large (no. 397), while the wall thickness is mainly medium. The rim morphology, together with the orientation of the very upper section of the vessel sides, suggest an attribution to the group of neckless jars, although the limited state of preservation does not enable a sound evaluation to be made. The vast majority of the examples belongs to the kitchen ware, but a relatively large number of plain ware examples have also been found, together with sporadic red slip ware sherds. The examples are wheelmade, with medium manufacture, related to the kitchen or to the common ware ceramic horizon. The incidence of the group among the neckless jars is medium-high.

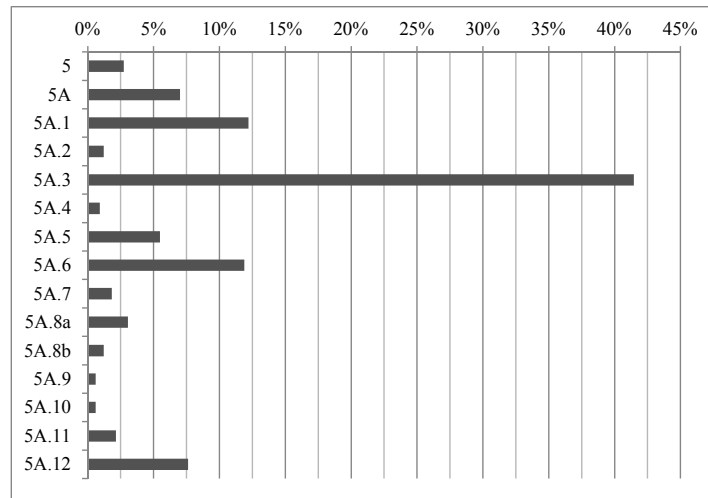


Diagram 14a: Type 5-Neckless Jars. Occurrence of main variants, sub-variants and lesser variants¹¹² – *Code layout*.

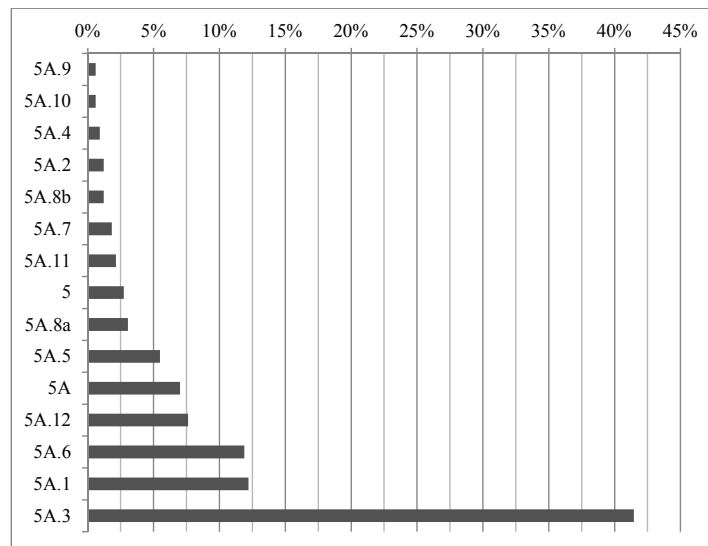


Diagram 14b: Type 5-Neckless Jars. Occurrence of main variants, sub-variants and lesser variants – *Bottom up layout*.

6 – (nos 398-460, 667-675) – *Necked Jars*. The cluster includes closed rim sherds probably to be related to medium size jars. Three main jar sub-categories have distinguished on the basis of the length of the neck as related to the vessel orifice: A) with short neck, B) with medium size neck, and C) with high neck. A fourth sub-category, (D), includes sparse specialised shapes, such as beak spouted jars. The aforesaid clusters are further subdivided into main and lesser variants, for a total of twenty-five necked jars types. High necked variants constitute the largest section of the necked jars inventory (30%), followed by short and medium-short necked variants (24% and 22% respectively). Poorly preserved rim sherds have been assigned to the general category of shape 6. Overall, necked jars constitute the second cluster in order of attestation among the totality of recorded shapes, representing about 18% of the inventory. The vast majority of the recovered examples is in plain and kitchen ware, although many other wares are attested as well.

¹¹² Percentages are calculated on the total of 328 type 5 diagnostic sherds.

6A – (nos 398-406, 667-668) – *Jars with short neck*. The category includes closed rim sherds that can be related to jars characterized by a very short neck or whose orifice corresponds to a sort of short collar or flange, mainly created by an outward bend of the rim. Sizes vary between medium-small (see no. 404 or 398) and medium large (no. 406). Five main variants have been distinguished on the basis of the orifice morphology and of sizes: 1) with everted rim, 2) with curved (hyperboloidal) neck and simple rim, 3) with curved (hyperboloidal) neck and thickened, tapered rim, 4) with thin walls and outside thickened, elongated rim, and 5) with vertical neck and outside thickened, tapered rim. Rim sherds whose state of preservation prevented attribution to any of the aforesaid categories have been assigned to the general group of shape 6A. Short necked jars are mainly in plain and kitchen ware, which represent 80% of the shape 6A inventory (40% each). A relatively large group is also in red slip ware (11%), while other classes are sparse (brown burnished ware and painted ware) or sporadic (yellow slip ware and pseudo brittle ware). The manufacture ranges from medium to medium-coarse, but finer samples are also attested. The ceramic horizons of reference include primarily those of the common and the kitchen wares. The most common production technique is wheel throwing, but handmade variants are also attested, such as nos 667-668, which are characterised by curved closed neck and simple, sharpened rim.

6A.1 – (nos 398-400, 672) – *Jars with short neck. Everted rim*. The group includes closed rim sherds of medium size jars whose short neck corresponds with the extension of the everted rim, creating a sort of flanged mouth. Two main variants have been identified: a) wheelmade, characterised by very short neck, and b) handmade, with standard short neck. The majority of recovered examples belong to variant *a*, while variant *b* is only sparsely attested. The shape is primarily found in plain and kitchen wares, but other wares, such as red slip, brown burnished, painted and yellow slip ware are also attested. A high variability is registered in the manufacture, which ranges from medium-fine to coarse. The ceramic horizons of reference, however, are mainly those of the common and of the kitchen wares.

6A.1a – (nos 398-400) – *Jars with short neck. Everted rim. Very short neck*. The group includes closed rim sherds of short necked jars characterized by a flanged mouth. The shoulder is either curved, with intermediate inclination (nos 399-400) or straight, almost vertical (no. 398). The very short neck, almost straight and open, coincides with the everted rim. The rim is mainly simple, but slightly thickened variants are also attested. Its profile is rounded or slightly sharpened. The sizes of the vessels range from medium-small to medium-large, with high variability of both rim diameters and wall thickness. Although related shapes are found in red slip, painted, brown burnished and yellow slip wares, the type is primarily found in plain and kitchen ware. It is wheelmade, with medium-fine to medium-coarse manufacture, related either to the kitchen or to the common ware ceramic horizon. The incidence of the group is rather high, corresponding to 10% of the necked jars inventory. Moreover, together with variant *b* of type 6A.1, some similarity can also be seen with neckless jars 5A.5 and with short necked jars 6A.2.

6A.1b – (no. 672) – *Jars with short neck. Everted rim. Handmade*. The category comprises sparse, closed rim sherds of short necked jars with flanged mouth that are distinguished from variant 6A.1a on the basis of either the flange length, shorter in variant *a*, and the building technology. The shoulder is curved, with intermediate inclination. The neck, almost flaring, coincides with the everted rim. The profile of the rim is simple and rounded. The sizes are medium-large, with medium-large rim diameters, around 20cm, and medium-thick walls. The type is in handmade red slip ware, with medium manufacturing, related to the common ware ceramic horizon. Evident similarities are observed with the handmade variant of type 6B.1 (no. 671) and with type 6A.2.

6A.2 – (no. 401) – *Jars with short neck. Curved neck and simple rim*. The group includes closed rim sherds of short necked jars with flanged mouth. The shoulder is either curved or straight, with intermediate inclination. The neck, almost hyperboloidal, coincides with the everted rim, which is slightly thickened and everted. The profile of the rim is simple, almost rounded. The sizes of the vessels are medium, with intermediate rim diameters and wall thickness. It is mainly a kitchen ware type, but related morphologies are attested in plain ware and, sporadically, in red slip and brown burnished ware. It is wheelmade, with manufacture ranging from medium to coarse, related to either the kitchen or the common ware ceramic horizons. The incidence of the group among the necked jars is intermediate, although there are similarities with types 6A.1a-b and 6B.1.

6A.3 – (no. 402) – *Jars with short neck. Curved neck and outside thickened, tapered rim*. The group includes closed rim sherds related to short necked jars. The shoulder is curved, with almost intermediate inclination, jointed to the short, hyperboloidal neck with a gentle curve. The rim is composite:

coherent with the orientation of the vessel upper portion and outside thickened, elongated, with almost tapered profile. The sizes are medium, with intermediate rim diameters and wall thickness. It is typically found in kitchen ware, wheelmade, with medium to coarse manufacture, related to the kitchen ware ceramic horizon. A single handmade example with geometric painted patterns belongs to the same morphological category. The incidence of the group among the necked jars is relatively low.

6A.4 – (nos 403-404) – *Jars with short neck. Thin walls and outside thickened, elongated rim.* The category includes sparse closed rim sherds related to short necked jars. The shoulder is curved, almost vertical or intermediately oriented. The junction between shoulder and neck is rather gentle. The neck is very short, vertically oriented. The rim is composite, either coherent with the orientation of the vessel upper walls and outside thickened (no. 404) or simple, everted and elongated (no. 403). The sizes of the vessels are varied, ranging from small (no. 404) to medium-large (no. 403). The type is found in red slip and brown burnished ware. It is wheelmade, with medium or medium-fine manufacture, relating to the common ware ceramic horizon.

6A.5 – (nos 405-406) – *Jars with short neck. Vertical neck and outside thickened, tapered rim.* The group includes closed rim sherds related to medium and large sizes short necked jars. The shoulder of the jar is almost straight, with intermediate inclination. The orifice includes a very short neck with almost vertical orientation and outside thickened rim, with sharpened or slightly tapered profile. A small ridge is present on the inner side, at the junction between shoulder and neck, while recurring ridges and corrugations may be located on the vessel outer sides. The sizes are medium-large, both the rim diameters and the wall thickness ranging from medium to large. It is mainly a plain ware type, although related morphologies are also found in red slip and kitchen ware. The type is wheelmade, with manufacture ranging from medium (in case of plain and kitchen wares) to medium-fine (red slip ware), and can be related either to the kitchen or, more frequently, to the common ware ceramic horizon. The incidence of the group among the necked jars is not substantial.

6B – (nos 407-429, 669-670) – *Jars with medium size neck.* The category comprises closed rim sherds that can be related to jars characterised by a neck of intermediate length. The vessels are generally smaller than short necked jars, ranging from medium-small to intermediate. Seven main variants have been identified on the basis of necks and rim profiles: 1) with curved neck and simple rim, 2) with collared neck and triangular rim, 3) with curved, closed neck, thin walls and simple rim, 4) with collared neck and ribbed rim, 5) with curved neck, everted, outside thickened rim and medium rim diameters, 6) with curved neck, everted rim and medium-small rim diameters, and 7) with curved, closed neck and slightly everted, thickened rim. The majority of the recovered samples belongs to the first variant, which accounts for roughly 12% of the inventory of jars with medium size neck. Also of note are variants 4, 3 and 5, each representing around 2.5-3% of the inventory, while variant 6, 2 and 7 are of minor incidence. Poorly preserved sherds which cannot be firmly related to the clusters mentioned here above, have been assigned to the general category of shape 6B. Among these, a few handmade examples have been identified (nos 669-670), characterized by vertical or slightly flaring neck and simple rim. The majority of the recovered samples is wheelmade, and belongs to the plain and the kitchen ware, close to the respective ceramic horizon. Minor wares include red slip, yellow slip and pseudo-brittle wares, while brown burnished, coarse grained and grey wares are only found occasionally. The manufacturing quality varies greatly, but can generally be related to the common ware ceramic horizon.

6B.1 – (nos 407-410, 671) – *Jars with medium size neck. Curved neck and simple rim.* The category includes closed rim sherds related to jars with medium size neck. The state of preservation of the recovered samples is usually limited to the very upper section of the vessel, so that it is not possible to make any firm evaluation of the morphology of the body. The shoulder of the vessel, however, is almost rounded, with intermediate inclination. It is joined to the short, hyperboloidal neck by a gentle change in the vessel profile. The rim is plain: coherent with the orientation of the neck and simple, with rounded profile. The sizes of the vessel are intermediate, characterized by intermediate rim diameters and medium thickness of the walls. It is primarily a plain ware type, although kitchen ware samples are also quite common. Related morphologies are attested in red slip, brown burnished and yellow slip wares, while painted and pseudo-brittle ware samples are sparse. The type is mainly wheelmade, although sporadic handmade sherds have also been found (no. 671 and Pl. 15: 5, K09.690). A high variability is registered in the quality of the manufacturing, which reflects the same variability as the wares. Overall, however, the ceramic horizons of reference are those of either the kitchen or the common ware. The incidence of the group among the necked jars is very

high (around 12%), corresponding to the 3rd cluster in order of attestation. Moreover, there are similarities with types 6A.1b and 6A.2.

6B.2 – (nos 411-412) – *Jars with medium size neck. Collared neck, triangular rim.* The category includes sparse closed rim sherds related to jars with medium size neck characterised by very thin walls and collared neck. The neck, in fact, almost coincides with the extension of the broadening, vertically oriented rim. The joint between shoulder and neck is rather gentle. The rim is thickened outside, with almost triangular section. A vertical handle may be located on the upper section of the vessel, departing from the collar. The jars are medium-small, with small and medium-small rim diameters and thin walls. It is typically found in pseudo-brittle and kitchen ware, wheelmade, with medium manufacture and close to the kitchen ware ceramic horizon.

6B.3 – (nos 413-415) – *Jars with medium size neck. Curved closed neck, thin walls and simple rim.* The group comprises closed rim sherds related to jars with medium size neck characterised, as with the previous variant, by thin walls. The shoulder of the vessel has intermediate orientation, gently joined to the curved closed neck. The rim is composite: simple and everted, with rounded or slightly sharpened profile. The jars are medium-small, with medium small rim diameters (around 14cm on average) and thin walls. It is a typical kitchen ware morphology, although plain and pseudo-brittle ware samples are also well attested. Wheelmade, with medium manufacture, this type is mainly to be related to the kitchen ware ceramic horizon, although a common ware ceramic horizon is likely in some cases. The incidence of the group among the necked jars is intermediate.

6B.4 – (nos 416-420) – *Jars with medium size neck. Collared neck, ribbed rim.* The category includes closed rim sherds related to jars with medium size neck characterised by collared and ribbed neck. The state of preservation of the recovered samples is usually limited to the very upper section of the vessel. To the extent that they are preserved, the shoulders of the jars are mainly straight, with almost vertical or intermediate inclination. They are almost abruptly joined to the rather short neck, which coincides with the outside thickened and ribbed rim. The vessels are rather small, with medium-small rim diameters (around 14cm on average) and thin walls. The type, which is always wheelmade, is typically found in kitchen and pseudo-brittle ware, both related to the kitchen ware ceramic horizon. Similar morphologies, however, are attested also in plain ware or, sporadically, in coarse grained ware. In those cases the manufacture is generally medium and more likely to be related to the common ware ceramic horizon. The incidence of the group among the necked jars is intermediate.

6B.5 – (nos 421-423) – *Jars with medium size neck. Curved neck, everted, outside thickened rim, medium mouthed.* The group includes closed rim sherds related to jars with medium size neck. The state of preservation of the recovered samples is usually limited to the very upper section of the vessel, including only the rim and neck. The neck curved almost to the point of being closed. The rim is outside slightly thickened and everted, usually downward hooked, similar to rim variants observed in types 6B.6, 6C.3 6C.4b and 6C.6b. The sizes of the jars are intermediate, with intermediate rim diameters (around 17cm on average) and medium-thick walls. The morphology is typically found in kitchen ware, with manufacturing quality ranging from coarse to medium. Related examples are, however, also found in plain ware, with almost medium manufacture, and in yellow slip ware, with slightly coarser manufacture. The type is always wheelmade and to be related either to the kitchen or to the common ware ceramic horizon. The incidence of the group among the necked jars is intermediate.

6B.6 – (nos 424-428) – *Jars with medium size neck. Curved neck, everted rim, medium-small mouthed.* The group includes closed rim sherds related to jars that are characterized by medium-high neck, intermediate between medium and high neck varieties, and medium-small rim diameters, similar to those of the high necked jars. The state of preservation of the recovered samples is generally limited to the very upper section of the vessel, including only the rim and neck. The neck is mainly curved, vertically oriented. The rim is simple or slightly thickened and everted, with either pointed or squared profile, recalling the rim morphologies observed in types 6B.5, 6C.3 6C.4b and 6C.6b. The sizes of the jars are medium, with medium-small rim diameters and medium thickness of the walls. Related morphologies, always wheelmade, are attested in different wares, primarily plain and painted wares, but sparse samples are also attested in red and yellow slip ware. The manufacturing quality is generally medium or, especially in the case of plain and yellow slip ware, medium-coarse, essentially to be related to the common ware ceramic horizon. The incidence of the group among the necked jars is relatively low.

6B.7 – (no. 429) – *Jars with medium size neck. Curved closed neck, slightly everted, thickened rim.* The category refers to a single, closed rim sherd belonging to a large mouthed jar with medium-high neck. The shoulder is almost vertical, with straight profile, jointed to the curved, closed neck by a sharp change of directrix. The rim is everted, slightly inside and outside thickened, outside bevelled. The jar is medium-large, with relatively large rim-diameter and medium-thick walls. The type is in coarse grained ware, wheelmade, with medium manufacture, mainly to be related to the common ware ceramic horizon.

6C – (nos 430-458, 673-675) – *Jars with high neck.* The cluster comprises closed rim sherds probably relating to medium size jars with relatively high neck. Compared to types 6B, the width of the mouth is usually smaller while the neck is higher. However, the state of preservation of the recovered samples is largely limited to a sole, upper section of the vessel, including only the rim and the neck. Nine main variants have been distinguished on the basis of the width of the mouth, of the profile of the neck and of the profile and orientation of the rim: 1) with straight neck, slightly everted and/or thickened rim, 2) with small rim diameter and outside thickened rim, 3) with vertical neck and everted, thickened rim, 4) with straight, open neck and outside thickened rim, 5) with cylindrical neck and slightly everted, simple rim, 6) with flaring neck, 7) with outside thickened, squared rim, 8) with flaring neck and medium-large rim diameter, and 9) with trefoil mouth. Most of the recovered examples belongs to variant 5 (around 15% of the high necked jar inventory). Among the other variants, whose incidence is considerably lower, variants 9 (4.5%), 6 (2.6%) and 2 (2.2%) are relatively common, while 4, 8, 1, 3 and 7, whose percentages range from 1.5 to 0.3%, are increasingly rarer. High necked jars are for the most part wheelmade, while only sparse handmade samples have been found. The morphology is most common in plain ware, which constitutes about 56% of the inventory. Red slip ware (16%) and yellow slip ware examples (7%) are also quite common, while painted and brown burnished ware are rarer. The manufacture is generally medium, related to the common ware ceramic horizon.

6C.1 – (nos 430-431) – *Jars with high neck. Straight neck, slightly everted/thickened rim.* The category gathers closed rim sherds related to high necked jars. The neck is mainly straight, vertical or slightly open. The rim is composite, either coherent with the orientation of the neck and outside thickened (no. 431), or simple and everted (no. 430). The sizes are intermediate, with variable rim diameters and medium thickness of the walls. The type is most frequently found in plain ware, but sparse samples are attested also in other wares, such as red slip, yellow slip, painted and brown burnished ware. It is wheelmade, with almost medium manufacture, related to the common ware ceramic horizon. The incidence of the type among the necked jars is relatively low, but slight similarities may be seen with type 6C.5.

6C.2 – (nos 432-436) – *Jars with high neck. Very small-mouthed, outside thickened rim with rounded profile.* The group includes closed rim sherds related to high necked jars with rather small rim diameters (around 10-12cm). There is marked variability in the profile and orientation of the neck, although it is most commonly straight and open. The rims are remarkably thickened on the outer side. The profile is varied, but mainly rounded on the upper side and pointed on the lower side, creating a short band around the upper border of the jar. The sizes are medium small, with limited rim diameters and wall thickness ranging from medium-small to medium. The morphology is commonest in plain ware, but related examples have been found also in red slip and yellow slip ware. It is wheelmade, with almost medium manufacturing quality, and related to the common ware ceramic horizon. The incidence of the group among the necked jars is intermediate.

6C.3 – (nos 437-441) – *Jars with high neck. Vertical neck, everted, thickened rim.* The category includes closed rim sherds related to high necked jars. The neck is vertically oriented, usually with curved profile, although straight examples are also sporadically attested (no. 437). The rim is typically everted, usually thickened. The profile of the rim is mainly rounded on the upper side and hooked on the lower, similar to rim morphologies observed in types 6B.5, 6B.6 6C.4b, 6C.6b and, to a lesser extent, 6C.7. The sizes are medium-small, with medium-small rim diameters and wall thickness ranging from small to medium. The type is found primarily in brown burnished and yellow slip ware. It is wheelmade, with medium manufacture, related to the common ware ceramic horizon. The incidence of the group among the necked jars is relatively low.

6C.4 – (nos 442-443) – *Jars with high neck. Straight, open neck and thickened rim.* The group includes closed rim sherds related to necked jars that are characterised by a straight and open neck and thickened rim, creating a narrow band around the orifice of the vessel. Two main variants have been identified based on the rim typology: a) with coherent rim, associated with an outside bevelled

profile, and b) with everted rim. The vessels are mainly small, with medium and small rim diameters and medium-thin walls. It is primarily a plain ware type, but related, sparse examples are attested also in other wares, such as yellow slip and coarse grained ware. It is wheelmade, with medium average manufacturing quality, mainly to be related to the common ware ceramic horizon. The incidence of the group among the inventory of the necked jars is intermediate.

6C.4a – (no. 442) – *Jars with high neck. Straight, open neck and thickened rim. Outside bevelled rim.* The group comprises closed rim sherds related to necked jars that are characterised by an open, straight neck and thickened rim. The rim broadens homogeneously on the outer and inner sides, coherently with the orientation of the vessel neck, its profile being outside bevelled. The sizes are medium small, with intermediate rim diameters and medium-thin walls. The morphology is typical of the simple ware. It is wheelmade, with medium or, more rarely, medium-fine manufacture, related to the common ware ceramic horizon. The incidence of the group among the necked jars is not substantial.

6C.4b – (no. 443) – *Jars with high neck. Straight, open neck and thickened rim. Everted rim.* The group includes closed rim sherds related to necked jars that are characterised by a straight, open neck. The rim is slightly thickened and everted, producing a typical profile that has the upper side curved, vertical outer side and lower side slightly hooked, similar to the rim types associated with variants 6B.5, 6B.6, 6C.3, 6C.6b and, to a lesser extent, 6C.7. The sizes of the vessels are medium-small, with intermediate rim diameters and medium-thin walls. The type is primarily found in plain ware, although sparse examples are also attested in other wares such as yellow slip and coarse grained ware. The examples are wheelmade, with medium to coarse manufacture, related to the common ware ceramic horizon. The incidence of the group among the necked jars is not, however, substantial.

6C.5 – (nos 444-445) – *Jars with high neck. Cylindrical neck, slightly everted, simple rim.* The category includes closed rim sherds related to necked jars that are characterised by a vertical, straight neck and slightly everted rim. The rim is simple, with almost squared profile. The sizes are intermediate, with intermediate rim diameters and medium thickness of the walls. The majority of the recovered examples is wheelmade, belonging to the plain ware. Red slip and painted ware specimens, however, are also quite frequent, while sporadic attestations of other categories include yellow slip, coarse grained, pseudo-brittle and grey wares. Sporadic handmade examples have also been recovered that present a similar morphology. The manufacturing quality, in accordance with the different ceramic classes, varies from fine to medium, but the type is predominantly to be interpreted within the common ware ceramic horizon. The incidence of the group among the necked jars is very high, representing 15% of the inventory. Moreover, some similarities can be seen with variants 6C.1, 6C.6a and 6C.8.

6C.6 – (nos 446-449, 674) – *Jars with high neck. Flaring neck.* The group comprises closed rim sherds related to high necked jars characterised by a curved and open neck. Two main variants have been identified on the basis of the rim typology: a) with slightly everted, simple rim, and b) with everted, thickened rim. The sizes of the sherds are intermediate. They are mainly wheelmade, although sparse handmade examples have been recovered as well. The most frequent wares include red slip and plain wares, but brown burnished ware examples are also well attested. The manufacture is almost medium, related to the common ware ceramic horizon. The incidence of the group, overall, is rather high.

6C.6a – (nos 446, 674) – *Jars with high neck. Flaring neck. Slightly everted, simple rim.* The category includes closed rim sherds related to necked jars characterised by an open neck with almost curved profile and slightly everted rim. The profile of the rim is simple, with almost squared, outside bevelled profile. The sizes of the vessels are intermediate, with medium rim diameters and medium thickness of the walls. The type, which is usually wheelmade, is primarily found in red slip and brown burnished ware. A single example, however, might be handmade (no. 674). The manufacture is mainly medium, related to the common ware ceramic horizon. The incidence of the specific variant among the necked jars is relatively low, but there are some similarities with type 6C.5.

6C.6b – (nos 447-449) – *Jars with high neck. Flaring neck. Everted, thickened rim.* The group includes closed rim sherds related to necked jars that are characterised by a flaring neck and everted rim. The rim is rather thickened, almost rounded on the upper side and slightly hooked on the lower, similar to rim morphologies already observed in types 6B.5, 6B.6, 6C.3, 6C.4b and, to a lesser extent, 6C.7. The sizes of the vessels, including rim diameters and wall thickness, range from small (no. 449) to medium-large (no. 448). It is mainly a red slip and plain ware type, but related morphologies are sparsely attested also in other wares, such as brown burnished and pseudo-brittle wares.

It is wheelmade, usually with medium manufacture, relating to the common ware ceramic horizon. The incidence of the specific variant among the necked jars is relatively low.

6C.7 – (nos 450-451) – *Jars with high neck. Outside thickened, squared rim.* The group gathers sparse, closed rim sherds related to high necked jars that are characterised by outside thickened rim. The profile of the rim is slightly elongated, with squared profile, creating a narrow band around the upper border of the vessel, quite similar to other examples already observed in types 6C.3, 6C.4b and 6C.6b. The sizes, including rim diameters and average wall thickness, are intermediate. The type is found in grey and coarse grained ware, wheelmade, with medium or medium-coarse manufacture, largely to be related to the common ware ceramic horizon.

6C.8 – (nos 452-454, 673, 675) – *Jars with high neck. Flaring neck, slightly everted/thickened rim, medium-large mouthed.* The group includes closed rim sherds related to medium-large size necked jars with flaring neck. The rim is either simple or slightly thickened on the outer side, very slightly everted, with rounded profile. The sizes are medium-large, with rather large rim diameters (around 20cm), and medium-thick to thick walls. It is primarily found in red slip ware, although related morphologies are found also in other wares, such as brown burnished, painted, plain and pink slip wares. It is principally wheelmade, but a few potsherds with quite similar morphology have been recovered also in handmade red slip ware (nos 673, 675). The manufacturing quality is generally medium, related to the common ware ceramic horizon. The incidence of the type among the necked jars is relatively low, but a few small similarities may be noted with type 6C.5.

6C.9 – (nos 455-458) – *Jars with high neck. Trefoil mouthed.* The category includes closed rim sherds related to different variants of necked jars that are characterised by a trefoil mouth. A marked variability is recorded in the specific profile of the necks, rims and sizes, suggesting that the shape is common to different ceramic traditions. Plain ware examples are most common, but the morphological variability is reflected also in the technological aspects, with the general shape being attested in many different wares, such as painted, red slip, yellow slip, pink slip, coarse grained and brown burnished ware. The shape is always wheelmade. The manufacturing quality ranges from fine to medium-coarse, usually to be related to the common ware ceramic horizon. The incidence of the type among the necked jars is intermediate.

6D – (nos 459-460) – *Beak spouted jars.* Only two rim sherds have been recovered that belong to beak spouted jars¹¹³. One is in plain ware (no. 460), with medium manufacture, mainly related to the common ware ceramic horizon, and the other is in red slip ware, characterised by medium-fine manufacture and more probably to be related to the fine ware ceramic horizon.

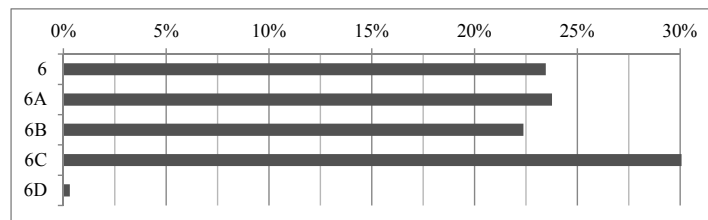


Diagram 15a: Type 6-Necked Jars. Occurrence of main variants¹¹⁴ – *Code layout.*

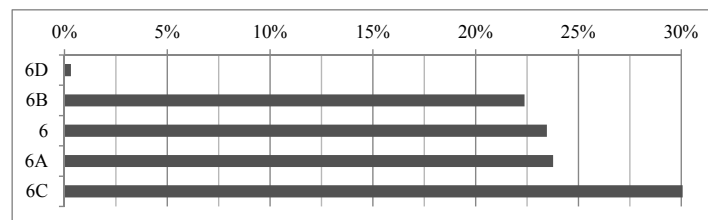


Diagram 15b: Type 6-Necked Jars. Occurrence of main variants – *Bottom-up layout.*

¹¹³ Other potsherds however have been recovered that belong to the same category, see type 20.

¹¹⁴ Percentages are calculated on the total of 648 type 6 diagnostic sherds.

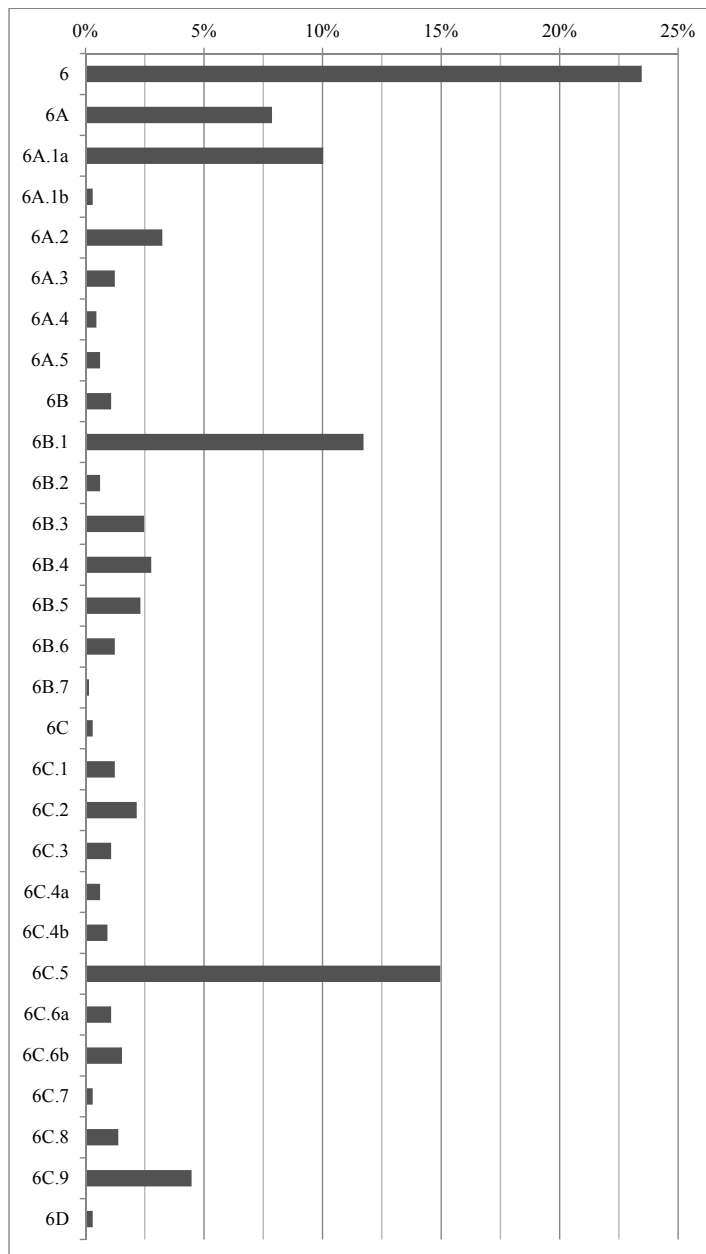


Diagram 16a: Type 6-Necked Jars. Occurrence of main variants, sub-variants and lesser variants¹¹⁵ – Code layout.

¹¹⁵ Percentages are calculated on a total of 648 type 6 diagnostic sherds.

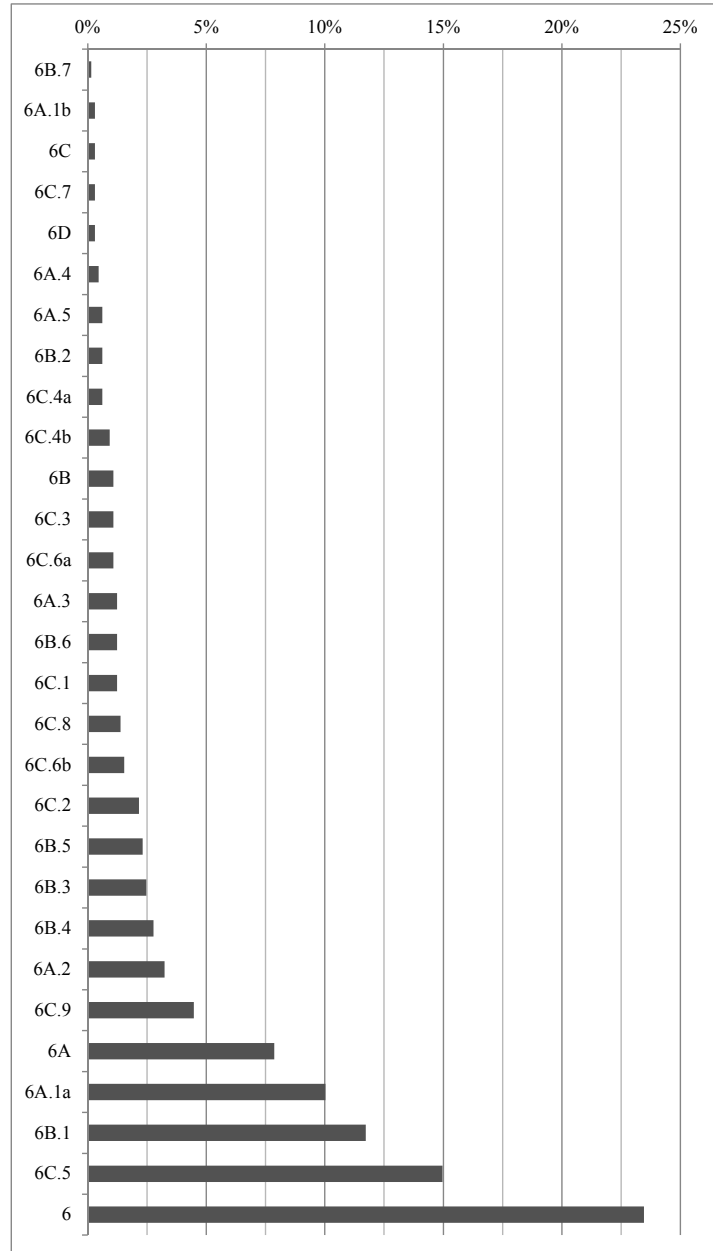


Diagram 16b: Type 6-Necked Jars. Occurrence of main variants, sub-variants and lesser variants – *Bottom-up layout*.

7A – (nos 461-464) – *Large Containers: deep, open*. The cluster includes thick, open rim sherds that probably are from medium-large or large, almost open containers. Despite the poor state of preservation, the examples included in this group are most likely deep or, at least, deeper than common bowls. The sherds have mainly straight sides, almost vertically oriented in many cases. The rims are composite: usually coherent with the orientation of the vessels upper sides and outside thickened, with variable profiles. With the exception of a single potsherd that could be handmade, the type is chiefly wheelmade, the manufacturing quality usually ranging from medium to coarse. The vast majority of the examples belongs to the plain ware, but red slip ware sherds are also quite common. Other wares include brown burnished, painted and yellow slip ware. The ceramic context of reference may be either the common or the storage ware. The incidence of the cluster among the inventory of identified morphologies is not substantial.

8 – (nos 465-491) – *Large Containers: deep, closed*. This group comprises thick walled rim sherds mainly related to large size containers or storage jars. The vessels have generally a large or very large mouth, but the overall shape of reference is generally closer to common closed shapes. Two main variants have been identified based on the average sizes: A) medium-large, relating to medium term storage, and B) very large, related to medium-long to long term storage. Further analysis includes nine more sub-variants mainly distinguished on the basis of the appearance of the opening. The majority of the sorted examples belong to the second variant. Poorly preserved rim sherds have been assigned to the general category of type 8 when not better attributable to a specific variant. Closed, large containers are prevailing in plain ware (49% of type 8 inventory), but red slip ware examples are also quite common (23% of type 8 inventory). Other wares, such as yellow slip and brown burnished ware, are rarer. The state of preservation of the examples is, in most cases, limited to the very upper section of the vessel, including the rim and, on occasion, only a small portion of the upper body. The rims usually show traces of rilling most probably to be related to the use of the wheel although, as far as the rest of the body is concerned, the joining of handmade sections is possible, especially in virtue of the large sizes. The manufacture ranges from medium to medium-coarse and coarse, but finer examples are also attested.

8A – (nos 465-474) – *Large Containers: deep, closed. Medium-large size*. The group comprises thick rim sherds mainly related to medium-large size, closed containers, intermediate between simple jars of type 5 and 6 and larger size storage vessels of type 8B. Four main variants have been identified based on the different morphologies of the openings: 1) with outside thickened rim, 2) with sharply everted, rounded rim, 3) with outside thickened, squared rim, and 4) with slightly everted, rounded rim. Variants 1 and 2 are more common, while only a few examples belong to variants 3 and 4. The vast majority of medium-large size closed containers are in plain ware, but red slip ware specimens are also common. Yellow slip and brown burnished examples, instead, are rarer. The manufacture is generally medium, to be related either to the common or, more likely, to the storage ware ceramic horizon.

8A.1 – (nos 465-469) – *Large Containers: deep, closed. Medium-large size. Outside thickened rim*. The group includes different variants of thick walled rim sherds related to medium-size storage jars that are characterized by an outside thickened rim. A short neck with straight, closed profile (no. 468), may be present, though more frequently the rim is directly joined to the vessel shoulder. The rim is composite, coherent with the orientation of the vessel upper sides and outside markedly thickened. The profile of the rim is varied, though most frequently it is tapered. The type is primarily found in plain ware, but other wares are also attested, such as red slip and yellow slip wares. The manufacture is medium, largely related to the storage ware ceramic horizon. The incidence of the group among storage jars is relatively high. Despite the difference in sizes, some morphological similarity may be noted with neckless jars of type 5A.5.

8A.2 – (nos 470-471) – *Large Containers: deep, closed. Medium-large size. Sharply everted, rounded rim*. The group includes thick walled rim sherds related to medium size storage jars that are characterized by a sharply everted rim which creates a sort of flanged mouth. The profile of the rim is elongated and rounded, inside bevelled. The type is found both in plain and red slip ware, with me-

dium manufacture, close to the storage ware ceramic horizon. The incidence of the group among storage jars is intermediate.

8A.3 – (nos 472-473) – *Large Containers: deep, closed. Medium-large size. Outside thickened, squared rim.* The group comprises sparse thick walled rim sherds related to medium size storage jars that are characterized by an outside thickened rim shaping a sort of squared flanged mouth. The profile of the rim is squared and elongated, upper side horizontal or inside bevelled, and outside vertically oriented. The type is found in plain, red slip and yellow slip ware, with medium manufacture, mainly related to the storage ware ceramic horizon.

8A.4 – (no. 474) – *Large Containers: deep, closed. Medium-large size. Slightly everted, rounded rim.* The group includes sparse, thick walled rim sherds related to medium size storage jars that are characterized by a simple, slightly everted rim. The profile of the rim is rounded and the eversion, unlike the sharp bend of type 8A.2, is created by a gentle curve. The type is found primarily in plain ware and, sporadically, in red slip ware. The manufacture is medium, related to the storage ware ceramic horizon.

8B – (nos 475-491) – *Large Containers: deep, closed. Very large size.* The group includes thick walled rim sherds related to large size storage jars. Five main variants have been identified based on the rim morphology: 1) with outside thickened, squared rim, 2) with outside thickened, rounded rim, 3) with outside thickened rim and triangular rim section, 4) with outside thickened, hooked rim, and 5) with everted, inside stepped rim. The most common morphologies are those of variants 2 and 3, with variants 1, 5 and 4 in decreasing proportions. As with the medium-large storage jars of group 8A, most of the recovered examples are in plain and red slip ware. The manufacturing quality is alternatively medium or medium-coarse and overall related to the storage ware ceramic horizon.

8B.1 – (nos 476-481) – *Large Containers: deep, closed. Very large size. Outside thickened, squared rim.* The category includes very thick walled rim sherds related to storage jars that are characterized by a large, outside thickened rim with squared and elongated profile. A relatively short neck (see no. 476) may be present, joined to the shoulder through a gentle curve. The type is primarily found in plain ware, but related morphologies are sparsely attested also in yellow and pink slip ware. The manufacture is mainly medium, related to the storage ware ceramic horizon. The incidence of the group among storage jars is medium-low.

8B.2 – (nos 482-484) – *Large Containers: deep, closed. Very large size. Outside thickened, rounded rim.* The group includes thick walled rim sherds related to storage jars that are characterized by an outside thickened rim, without neck. The joint between rim and shoulder is gentle. The profile of the rim is varied, although it is more generally either rounded or slightly sharpened. The type is found both in plain and red slip ware. The manufacturing quality varies greatly, ranging primarily from coarse to medium, although finer samples are attested as well. The ceramic horizon of reference is that of the storage ware. The incidence of the group among storage jars is relatively high.

8B.3 – (nos 485-490) – *Large Containers: deep, closed. Very large size. Outside thickened rim with triangular section.* The group includes thick walled rim sherds related to different variants of storage jars characterized by an outside thickened rim with triangular section. The rim rests directly over the shoulder, which has an almost straight profile. Different orientations are recorded, indicating diverse body shapes. The profile of the rim is outside sharpened, more or less elongated. The group includes a majority of plain ware sherds, but red slip ware samples are also frequent. The manufacture ranges primarily from coarse to medium, although finer pieces have also been found. The ceramic horizon of reference is that of the storage ware. The incidence of the type among storage jars is medium-high.

8B.4 – (no. 491) – *Large Containers: deep, closed. Very large size. Outside thickened, hooked rim.* The category refers to a single very thick rim sherd related to a large storage vessel. The rim, which lies directly on the shoulder, is thickened on the outside and the profile rounded on the upper side and hooked on the lower. The sample is in plain ware, with medium-coarse manufacture, related to the storage ware ceramic horizon.

8B.5 – (no. 475) – *Large Containers: deep, closed. Very large size. Everted, inside stepped rim.* The category includes thick rim sherds related to storage jars that are characterised by a sharply everted rim with inside stepped profile, most probably in view of the use of a lid. The type is found both in plain and red slip ware, with medium manufacture, close to the storage ware ceramic horizon. The incidence of the group among storage jars is relatively low.

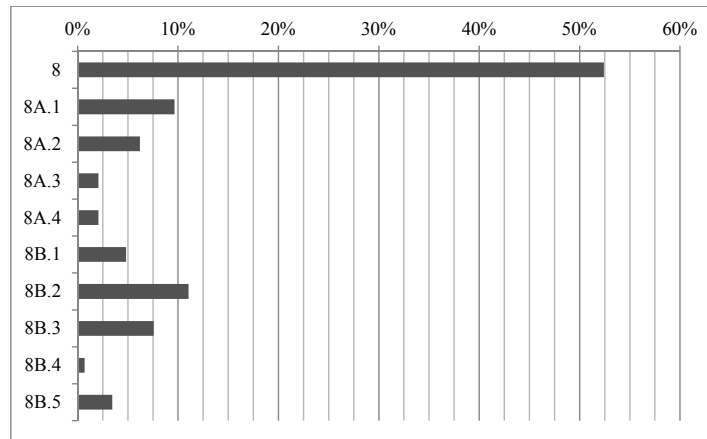


Diagram 17a: Type 8-Large, Deep, Closed Containers. Occurrence of main variants and sub-variants¹¹⁶ – *Code layout*.

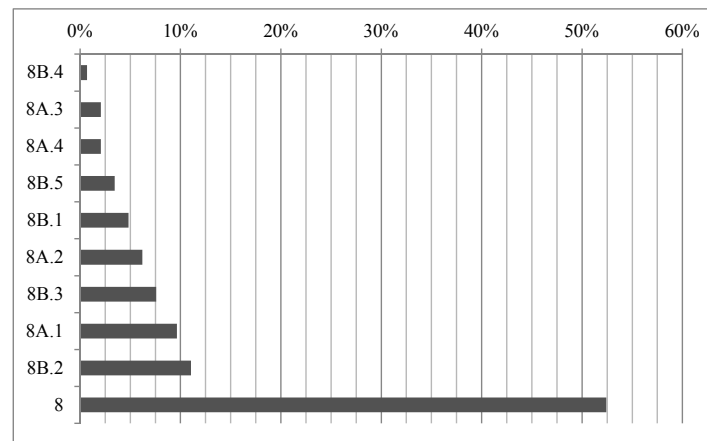


Diagram 17b: Type 8-Large, Deep, Closed Containers. Occurrence of main variants and sub-variants – *Bottom-up layout*.

9 – (no. 552; Pl. 23: 5, K12.1131) – *Lids*. The category comprises different variants of rim sherds probably to be related to lid types. The group includes plain, red slip and painted examples, clearly belonging to different ceramic traditions. The manufacturing quality varies greatly, suggesting a relation either with the common or with the fine ware ceramic horizon. The incidence of the group among the total number of analysed shapes, however, is not substantial.

10 – *Stands*. The category includes a single rim sherd that probably pertains to a stand morphology. The example is in plain ware, probably handmade, with medium manufacture, to be related to the common ware ceramic horizon.

11 – (no. 553) – *Strainers*. Only sparse potsherds have been recovered that are related to strainer typologies. A single rim sherd has been recovered (no. 553) that is mainly shaped like bowls. Most of

¹¹⁶ Percentages are calculated on the total of 145 type 8 diagnostic sherds.

the pierced examples found relate, instead, to wall sections, either of strainers or of filtered spouts¹¹⁷. They are mainly in plain ware, sporadically in kitchen ware and apparently wheel-made. The manufacturing quality ranges from medium to coarse, mainly relatable to the common ware ceramic horizon.

W – (nos 554-561) – *Undetermined, scarcely preserved shapes*. A number of potsherds has been retained as diagnostic since they show usually diagnostic features but are difficult to interpret since they are either unusual or very poorly preserved. The category is rather heterogeneous, including diverse morphologies and wares (see § 2.2.2).

Z – (nos 492-539) – *Undetermined Shapes*. The cluster includes a series of sherds which, due to the poor state of preservation, are of uncertain morphological attribution. The sherds are, in fact, generally limited to the rim and the very upper section of the vessels body, which generally relates to cylindrical or truncated cone shapes. They seem, therefore, most probably to be related to large (variants A and C) or small (variant B) mouthed vessels with a high neck, craters, barrels, squat jars or, in the case of small rim diameters and thin walls, small jars. Three main variants have been identified: A) most probably to be related to large mouthed, necked vessels and craters, B) small jars, and C) large mouthed vessels. Most of the recovered examples belong to the first variant, whose incidence maintains some value also among the totality of analysed shapes (5%). Overall, the incidence of the cluster among the totality of shapes is intermediate. The morphology is more commonly found in red slip ware (around 40% of shape Z), followed in order of attestation by plain ware (21%) and painted ware samples (19%). Among other wares, there are a fair number of brown burnished (10%) and yellow slip ware examples (5%), while other classes are sporadic. The manufacture is mainly medium, although finer and coarser samples are also attested. The functional context of reference, however, is probably that of the common ware.

ZA – (nos 492-536) – *Undetermined Shapes. Large, necked vessels/craters*. This category includes rim sherds of large-mouthed, necked vessels probably from large, necked jars or craters. Eleven main variants and seven lesser variants have been identified based on rim morphologies, for a total of fifteen specific types (see below). The rims mainly have a ledged shape, generally everted or thickened outside, with squared, rounded or tapered profile. Among the most common elements, the presence of a step on the inner side is rather frequent (see types ZA.8, ZA.10 and ZA.3b). Shapes ZA are wheel-made, most commonly in red slip ware (39%) and painted ware (21%). Secondary wares include plain (19%), brown slip (10%) and yellow slip wares (5%). The manufacture is largely medium, relating to the common ware ceramic horizon.

ZA.1 – (no. 492) – *Undetermined Shapes. Large, necked vessels/craters. Simple, tapered rim*. The group includes rim sherds probably relating to straight and open necks. The rim is slightly thickened on the outer side, with the upper side profile horizontally oriented and the outer side profile tapered. The type is typically found in red slip ware, with medium manufacture, generally related to the common ware ceramic horizon. The incidence of the variant among the group of shapes Z is medium low.

ZA.2 – (nos 493-497) – *Undetermined Shapes. Large, necked vessels/craters. Everted, outside thickened rim*. The category comprises rim sherds probably relating to large, necked vessels. They are characterised by a more or less everted and thickened rim, shaping a band around the vessel's upper border. Three main variants have been identified on the basis of typological differentiation of the rim: a) with markedly everted rim, with squared profile, b) with thickened, elongated rim, with rounded profile, and c) with markedly everted rim, with rounded profile. The markedly thickened rim with squared profile (variant a) is the most common, followed by the rounded profile variant (variant c). Variant b is, instead, only sporadic. The type is mainly in red slip ware, with medium manufacture, relating to the common ware ceramic horizon.

ZA.2a – (no. 493) – *Undetermined Shapes. Large, necked vessels/craters. Everted, outside thickened rim. Markedly everted, squared rim*. The category includes rim sherds relating to large, necked vessels. The neck is open, almost straight. The rim is markedly everted, thickened, with squared profile, the upper and lower margins being markedly sharpened. The type is almost exclusively a red slip ware

¹¹⁷ There are a total of 10 examples of pierced potsherds. Only two specimens comprised a section of rim, and have been assigned to the inventory of main shapes.

morphology, with medium manufacture, close to the common ware ceramic horizon. The incidence of the variant among the Z group of shapes is rather low.

ZA.2b – (nos 494-495) – *Undetermined Shapes. Large, necked vessels/craters. Everted, outside thickened rim. Elongated, rounded rim.* The group includes sparse rim sherds relating to large, necked vessels. The neck is markedly open, whereas the rim is slightly everted and slightly thickened, elongated, with rounded profile. The morphology is typical of the red slip ware. Samples are of medium manufacturing quality, mainly relating to the common ware ceramic horizon.

ZA.2c – (no. 497) – *Undetermined Shapes. Large, necked vessels/craters. Everted, outside thickened rim. Markedly everted, rounded rim.* The group comprises rim sherds relating to large, necked vessels characterised by an open neck and a markedly everted and thickened rim. Unlike type ZA.2a, the profile of the rim is mainly rounded. The morphology is typical of the red slip ware. It is of medium manufacture and is related with the common ware ceramic horizon. The incidence of the variant among the group of Z shapes is low.

ZA.3 – (nos 498-503) – *Undetermined Shapes. Large, necked vessels/craters. Outside thickened, tapered rim.* The category includes rim sherds relating to large, necked vessels characterised by an open neck and outside thickened rim with tapered profile. Two main variants, *a* and *b*, have been identified on the basis of the presence or absence of a typical step on the inner side profile of the rim. The first variant, without step, is rarer, and more typically found in brown burnished ware; the second, stepped variant, which is far more common, is found both in red and plain ware. The manufacture is mainly medium, relating to the common ware ceramic horizon.

ZA.3a – (no. 498) – *Undetermined Shapes. Large, necked vessels/craters. Outside thickened, tapered rim. Inside angled.* The category includes rim sherds relating to large, necked vessels characterised by an open neck, outside thickened rim with tapered profile, mainly outside bevelled, and connected to the neck by a sharp angle on the inner side. The morphology is found primarily in brown burnished ware, but red slip and yellow slip ware samples are also sporadically attested. The manufacture is mainly medium, relating to the common ware ceramic horizon. The incidence of the variant among the group of Z shapes is low.

ZA.3b – (nos 499-503) – *Undetermined Shapes. Large, necked vessels/craters. Outside thickened, tapered rim. Inside stepped.* As with variant ZA.3a, this category includes rim sherds relating to large, necked vessels characterised by an open neck, outside thickened rim with tapered profile, mainly outside bevelled. The presence of a typical step or a large groove on the inner side profile distinguishes sub-variant *b* from *a*. The morphology is found in both red slip and plain ware, with medium manufacture, mainly relating to the common ware ceramic horizon. The incidence of the group is relatively high.

ZA.4 – (nos 504-505) – *Undetermined Shapes. Large, necked vessels/craters. Outside thickened, elongated rim with various profile.* This group comprises various morphologies of poorly preserved rim sherds relating to large, necked vessels that are characterised by an outside thickened and elongated rim, shaping a more or less thick band around the upper sides of the vessels. The sample is rather heterogeneous. Most of the recovered sherds belong to the red slip ware but plain, painted and brown burnished ware specimens are also common. The manufacturing quality varies from medium-fine to medium-coarse, but the type seems to be chiefly related to the common ware ceramic horizon.

ZA.5 – (nos 506-507) – *Undetermined Shapes. Large, necked vessels/craters. Outside thickened, elongated rim with rounded profile.* The category comprises almost vertical rim sherds relating to large, necked vessels characterised by an almost vertical neck, with either straight or curved profile, and outside thickened, elongated rim. The rim has a mainly rounded profile. The morphology is common to different wares, such as plain, brown burnished, pink slip and painted ware. The manufacturing quality is medium, close to the common ware ceramic horizon. The frequency of the variant among type Z shapes is intermediate.

ZA.6 – (nos 508-511) – *Undetermined Shapes. Large, necked vessels/craters. Outside thickened, elongated rim with squared profile.* The category includes open or almost vertically oriented rim sherds relating to large, necked vessels that are characterised by an outside thickened, elongated rim with squared profile. The morphology is very close to that of type ZA.5, from which it is distinguished by the profile of the rim. Main morphological variants include simple profiles (variant *a*) and inside stepped rim profiles (variant *b*), which are most common. The type is attested primarily in red slip and plain wares, with medium or medium-fine manufacture mainly relating to the common ware ceramic horizon.

ZA.6a – (nos 508-509) – *Undetermined Shapes. Large, necked vessels/craters. Outside thickened, elongated rim with squared profile. Simple.* The group includes open or almost vertically oriented rim sherds relating to large, necked vessels that are characterised by an outside thickened, elongated rim

and distinguished from variant ZA.5 on the basis of the squared rim morphology. The type is primarily found in plain ware, but coarse grained ware and red slip ware samples are also sporadically attested. The manufacture is generally medium, relating to the common ware ceramic horizon. The incidence of the variant among the group of Z shapes is rather low.

ZA.6b – (nos 510-511) – *Undetermined Shapes. Large, necked vessels/craters. Outside thickened, elongated rim with squared profile. Inside stepped.* The group includes open or almost vertically oriented rim sherds relating to large, necked vessels characterised by an elongated rim, thickened on the outside and with a squared profile. It differs from variant ZA.6a in having a typical step or large groove located on the inner side of the rim profile. The morphology is typically found in red slip ware, but plain and yellow slip ware samples are also sparsely attested. The manufacture ranges from medium-fine to medium, mainly relating to the common ware ceramic horizon. The incidence of the variant among the group of Z shapes is medium low.

ZA.7 – (no. 512) – *Undetermined Shapes. Large, necked vessels/craters. Thickened rim with rounded profile, slightly stepped inner side.* The group includes rim sherds relating to large, necked vessels that are characterised by a thickened rim with rounded profile, horizontally oriented. The neck is open, either straight or curved. The morphology is typical of red slip ware, although related types are sporadically found in plain and brown burnished ware. The manufacture is mainly medium, relating to the common ware ceramic horizon. The frequency of the variant among shape type Z is intermediate.

ZA.8 – (nos 513-523) – *Undetermined Shapes. Large, necked vessels/craters. Vertical neck and everted rim, inner side stepped.* The category comprises different types of rim sherds relating to large, necked vessels characterised by an almost straight and vertical neck and everted rim. The profile of the rim is usually rounded, with a characteristic step or a large groove on the inner side. It may be either simple (nos 514-515) or thickened (nos 513, 520, 523). Close morphological similarities are shared with variant ZA.10, which includes more markedly everted rim variants that are mainly associated with open necks. The morphology is typical of the painted ware, which groups 45% of shape ZA.8 sherds. Similar shapes in plain ware, however, are also rather common (21%), while red slip, yellow slip and brown burnished ware samples are rarer (10% each). The manufacture is generally medium, relating to the common ware ceramic horizon. Among the specific variants of shape ZA, type ZA.8 is the most common, representing about 15% of the Z shape inventory.

ZA.9 – (nos 524-525) – *Undetermined Shapes. Large, necked vessels/craters. Intermediate between large, necked vessels and large, mouthed vessels.* This group refers to sporadic sherds with outside thickened rim whose general morphology, as far as we can judge given their state of preservation, might be considered intermediate between large, necked vessels of type ZA and large mouthed vessels of type ZC. The examples belong to painted and pink slip ware. They are of either medium or fine manufacture, close to the common ware ceramic horizon.

ZA.10 – (nos 526-534) – *Undetermined Shapes. Large, necked vessels/craters. Markedly everted, globoid rim, stepped inside.* The group includes different types of rim sherds relating to large, necked vessels that are characterised by a markedly everted, thickened rim with inner step. The profile of the rim is usually globoid, with rounded outer side, and the inner side grooved or stepped. The neck, although rarely well preserved, is mainly open. As with the closed variant ZA.8 (see above), the morphology is largely typical of painted ware, although red slip ware samples are sparsely attested. The manufacture is mainly medium, related to the common ware ceramic horizon. The incidence of the group is relatively high.

ZA.11 – (nos 535-536) – *Undetermined Shapes. Large, necked vessels/craters. Various.* The category refers to sporadic rim sherds with uncommon rim profile, mainly related to large, necked vessels. Examples are in red slip and brown burnished ware, with medium manufacture, related to the common ware ceramic horizon.

ZB – (nos 359-360) – *Undetermined Shapes. Probable small Jars. Slightly everted, straight sides/neck.* The category includes sparse poorly preserved rim sherds that are probably to be related to small jars. They are characterized by a relatively high, slightly everted neck with straight sides. The small rim is mainly composite: slightly everted or outside thickened, with tapered profile. The type is mainly found in red slip and yellow slip ware, but sporadic examples are attested also in brown burnished ware. It is wheel-made, of medium or medium-fine manufacture, related either to the fine or to the common ware ceramic horizon.

ZC – (nos 537-539) – *Undetermined Shapes. Large mouthed vessels.* The category includes almost closed rim sherds relating to large mouthed vessels that are characterised by different variants of outside thickened rim. The sizes of the vessels are intermediate, with rim diameters around 25-30cm, and medium-thick to thick walls. Only the upper section of the vessels wall is preserved, and it is either almost vertically oriented or slightly closed. The morphology is primarily found in plain ware, although

red slip ware samples are also common. The manufacturing quality ranges from medium to fine, essentially relating to the common ware ceramic horizon.

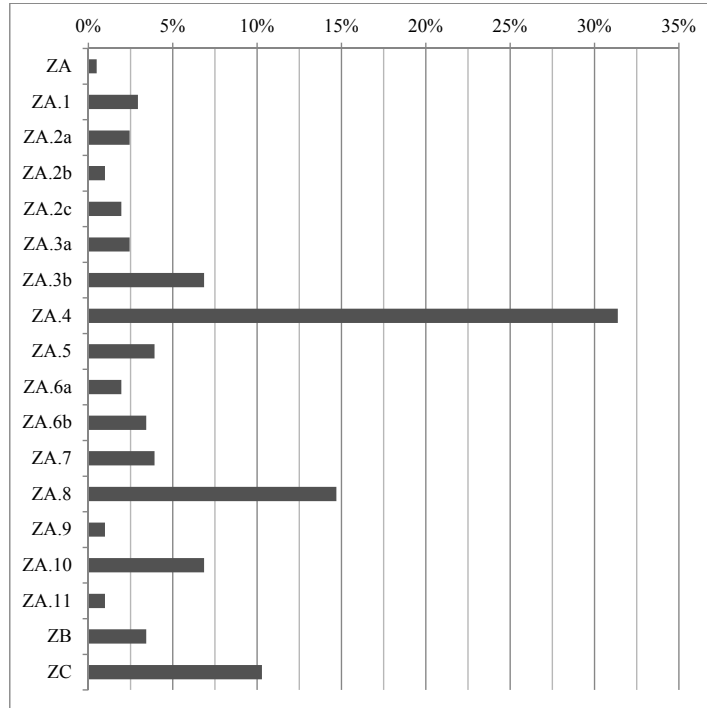


Diagram 18a: Type Z-Undetermined, necked vessels. Occurrence of main variants, sub-variants and lesser variants¹¹⁸ – Code layout.

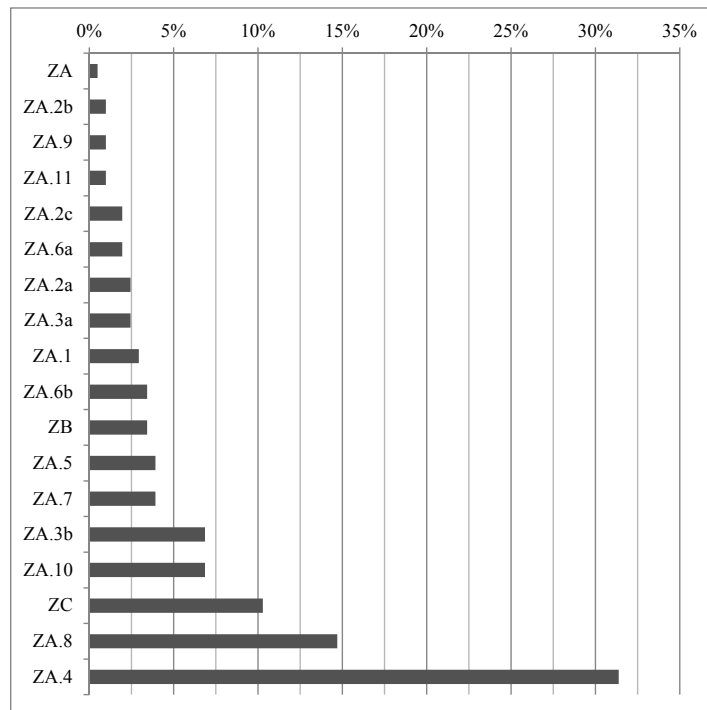


Diagram 18b: Type Z-Undetermined, necked vessels. Occurrence of main variants, sub-variants and lesser variants – Bottom-up layout.

¹¹⁸ Percentages are calculated on the total of 204 type Z diagnostic sherds.

2.2.4.₃ *Other morphological components*2.2.4._{3.1} *Beaks and spouts**List of beak and spout types*20 – *Beaks and spouts*20A – *Beaks and spouts*. Beaks with half cone or half truncated-cone shape20A.1 – *Beaks and spouts*. *Beaks with half cone or half truncated-cone shape*. Plain ending20A.2 – *Beaks and spouts*. *Beaks with half cone or half truncated-cone shape*. Hooked ending20B – *Beaks and spouts*. Half tubular spouts20B.1 – *Other Shapes*. *Half tubular spouts*. Short20C – *Beaks and spouts*. Tubular spouts20C.1 – *Beaks and spouts*. *Tubular spouts*. Cylindrical section, elongated20C.2 – *Beaks and spouts*. *Tubular spouts*. Conical section, small20C.3 – *Beaks and spouts*. *Tubular spouts*. Cylindrical section, short20C.4 – *Beaks and spouts*. *Tubular spouts*. Slightly hooked ending (slightly beaked spouts)20C.5 – *Beaks and spouts*. *Tubular spouts*. Markedly hooked ending, miniaturistic (miniaturistic, beaked spout)

20 – (nos 540- 551) – *Beaks and spouts*. This category includes potsherds related to pouring activities, thus including beaks and spouts. The state of preservation of the sherds is frequently limited to the projecting element or to a section of this, although fragments including part of the vessel wall have also been found. The sum of potsherds comprehensive of beaks and spouts amounts to 42 diagnostic sherds¹¹⁹. Three main variants have been identified: A) beaks, which are open, characterised by half cone or truncated-cone shape, B) half tubular spouts, that are open and characterised by semi-cylindrical section, and C) tubular spouts, which have the shape of tubes. They are primarily found in plain and red slip ware. In relation to the inventory of main shapes, the incidence of spouts and vessels represents about 1%, therefore constituting a well attested component. The vast majority of the examples found belong to variant C, followed in order by variant A and B. Eight more detailed variants have been identified on the basis of the rim morphology, among which the beaked/hooked variants (20C.4 and 20A.2) are the most commonly found. Beak type 20A.2 is the most common red slip ware variant, while the slightly beaked spouts of type 20C.4 correspond to the most common plain ware variant.

20A – (nos 540-545) – *Beaks with half cone or half truncated-cone shape*. Within the beak category, potsherds are grouped relating to pouring devices consisting of a sloping surface with the upper side open. This is shaped like a half cone or a truncated-cone. Two main distinctions have been made concerning the morphology of the rims of the beak: 1) with plain ending, which are rarer, and 2) with hooked ending. The sherds are primarily in red slip ware, frequently of medium or medium-fine manufacture, to be related to either the common or, more rarely, the fine ware ceramic horizon.

20A.1 – (nos 540, 542) – *Beaks with half cone or half truncated-cone shape*. *Plain ending*. This category includes potsherds related to beaks whose rim is mainly simple, that is non-thickened, with either rounded or squared profile. It is mainly in red slip ware, with medium or medium-fine manufacture, to be related to the common or, more rarely, to the fine ware ceramic horizon. The incidence of the group among the totality of shape 20 samples is rather low.

20A.2 – (nos 541, 543-545) – *Beaks with half cone or half truncated-cone shape*. *Hooked ending*. The category includes potsherds related to beaks, usually of half-truncated cone shape, whose rim presents a typical hook-shape thickening. As with variant 2A.1, the type is mainly in red slip ware, with medium manufacture and can be related to the common or, more rarely, to the fine ware ceramic horizon. It is one of the most common variety among the shape 20 samples.

20B.1 – *Half tubular spouts*. *Short*. The category comprises a few potsherds related to half tubular spouts. They are characterised by a semi-cylindrical section and are relatively short. They are mainly

¹¹⁹ Two further examples, which are characterized by a better state of preservation, pertain to type 6D.

in red slip ware, with medium manufacturing quality, related to the common ware ceramic horizon. The incidence of the group among the totality of category 20 shapes is intermediate.

20C – (nos 546-551) – *Tubular Spouts*. The category includes potsherds relating to pouring devices that, unlike from beaks and half tubular spouts, are shaped like tubes. Five main variants have been identified based on the section, which is cylindrical or conical, the length of the spout, short or elongated, and on the rim typology, which is plain or hooked. The variants are as follow: 1) with elongated cylindrical section, 2) with conical section and short tube, 3) with cylindrical section and short tube, 4) with slightly hooked ending, and 5) with markedly hooked ending and miniaturistic. Most of the recovered examples belong to the 4th variant, which is followed, in order of attestation, by variant no. 1. The tubular spouts are found in both in plain and red slip ware, with generally medium manufacture, related to the common ware ceramic horizon.

20C.1 – (no. 546) – *Tubular Spouts*. *Cylindrical section, elongated*. This group includes potsherds of elongated, tubular spouts that have a cylindrical section. The type is found in both plain and red slip ware, mainly with medium manufacture and related to the common ware ceramic horizon. It is the third variety in order of attestation among shape 20 family.

20C.2 – (no. 547) – *Tubular Spouts*. *Conical section, small*. The group comprises potsherds relating to quite small, tubular spouts that are characterised by a conical section. The type is primarily found in red slip ware, with medium or fine manufacture, generally related to the common ware ceramic horizon. The incidence of the group, however, is rather low.

20C.3 – (no. 548) – *Tubular Spouts*. *Cylindrical section, short*. The group includes potsherds that relate to short, tubular spouts with a cylindrical section. The type, which is characteristically in plain ware, has medium manufacture relating to the common ware ceramic horizon. The incidence of the group, however, is rather low.

20C.4 – (nos 549-550) – *Tubular Spouts*. *Slightly hooked ending (slightly beaked spouts)*. This group, which is the most common among shape 20 types, includes potsherds relating to tubular spouts, usually with a tubular section, and slightly hooked ending. They are primarily in plain ware, with medium or, more rarely, medium-fine manufacture, relating to the common ware ceramic horizon.

20C.5 – (no. 551) – *Tubular Spouts*. *Markedly hooked ending, miniaturistic (miniaturistic, beaked spout)*. The category refers to a single sherd of a miniaturistic spout with markedly hooked ending. It is in red slip ware, of fine manufacture, generally related to the fine ware ceramic horizon.

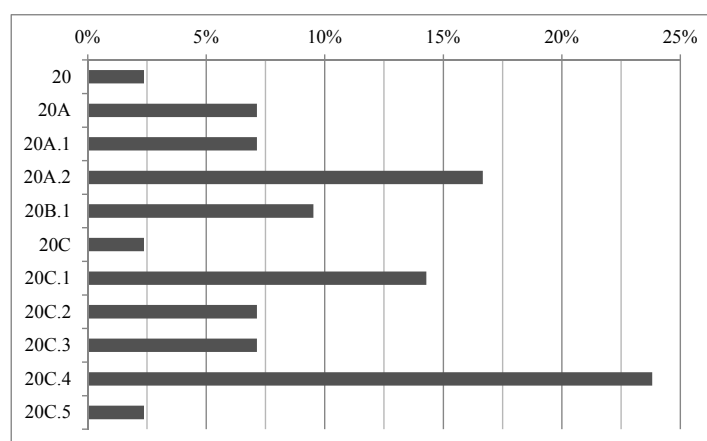


Diagram 19a: Type 20-Beaks and spouts. Occurrence of main variants and sub-variants¹²⁰ – Code layout.

¹²⁰ Percentages are calculated on the total of 42 type 20 diagnostic sherds.

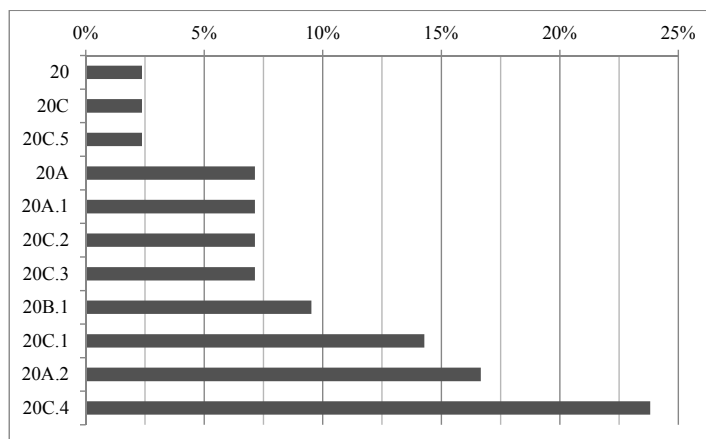


Diagram 19b: Type 20-Beaks and spouts. Occurrence of main variants and sub-variants – *Bottom-up layout*.

2.2.4._{3,2} Bases

List of base types

- B1 – Flat base
- B2 – Curved base
- B3 – Flattened base, with curved profile
- B4 – Pointed base
- B5 – Ring base (hollow ring)
- B6 – Solid-ring base
- B7 – Pedestal base
- B10 – Tripod base

The largest section of the base inventory, which is composed by 464 diagnostic elements, belongs to flat bases (50%), followed in order of attestation by ring bases (31%). Less frequent are solid-ring bases (7%) and flattened bases with curved profile (5%), while other base types, like curved, pointed, pedestal and tripod bases are sparse. Poorly preserved samples have been registered as generic bases.

B1 – (nos 33, 562-565, 676) – *Flat base*. The vast majority of flat bases are in plain ware (47%). Brown burnished (13%), yellow slip (12%), red slip (9%), kitchen (9%) and grey wares (7%) samples are also rather common, while other classes are sporadic. Although a few examples have been found which relate to handmade vessels, the type is most frequently related to wheelmade specimens. The manufacturing quality varies considerably, ranging from medium-coarse to fine. The examples relate, in fact to the common, storage or kitchen ware ceramic horizon.

B2 – (nos 566-567) – *Curved base*. The majority of curved bases are in plain ware, although kitchen, red slip and yellow slip ware samples are sporadically attested. The manufacture is generally medium, related to the common or to the kitchen ware ceramic horizon.

B3 – *Flattened base, with curved profile*. Most of the flattened bases with curved profile belong to the plain ware horizon, but other ceramic classes are also well attested, such as brown burnished and yellow slip wares. Grey, red slip, and kitchen ware samples are, instead, sporadic. The manufacture is generally medium, relating to the common ware ceramic horizon.

B4 – (nos 568-569) – *Pointed base*. Pointed bases are primarily found in plain ware, but red slip ware examples are also common, while yellow slip examples are sporadic. The manufacture is generally medium, relating to the common ware ceramic horizon.

B5 – (nos 570-578) – *Ring base (hollow ring)*. Recovered ring bases are primarily in plain ware (56%) although red slip (17%) and brown burnished ware examples (12%) are also common, followed in order of attestation by grey ware samples (7%). Other ceramic classes are sporadic. There is marked variation in the manufacturing quality, which ranges from medium to very fine, relating either to the common or to the fine ware ceramic horizon.

B6 – (no. 579) – *Solid-ring base*. Solid-ring bases chiefly belong to the plain ware, although sporadic examples have been found in other wares, such as brown burnished, grey, red slip and yellow slip.

The manufacturing quality varies greatly, from coarse to fine but the examples are mainly related to the common ware ceramic horizon.

B7 – (nos 580-581) – *Pedestal base*. The category of pedestal bases includes a few examples in different wares, such as plain, orange, brown burnished and red slip. The manufacture ranges from medium to very fine, connected either to the fine or to the common ware ceramic horizon.

B10 – (no. 582) – *Tripod base*. The category of tripod bases includes a few, very heterogeneous examples. They pertain to a fine example of brown burnished ware (no. 582), relating to the fine ware ceramic horizon, and to a plain ware example, mainly related to the common ware ceramic horizon.

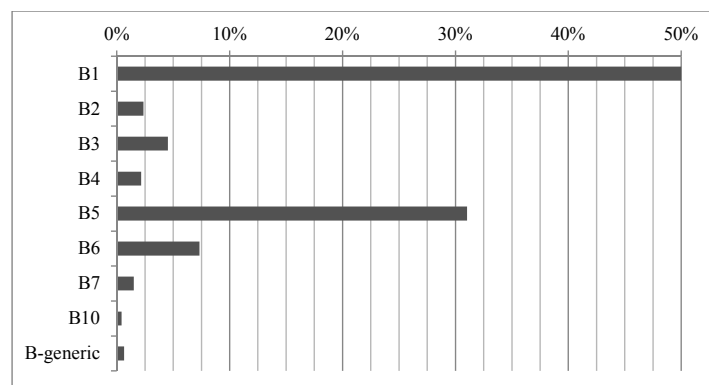


Diagram 20a: Type B-Morphology of bases. Occurrence of main variants¹²¹ – *Code layout*.

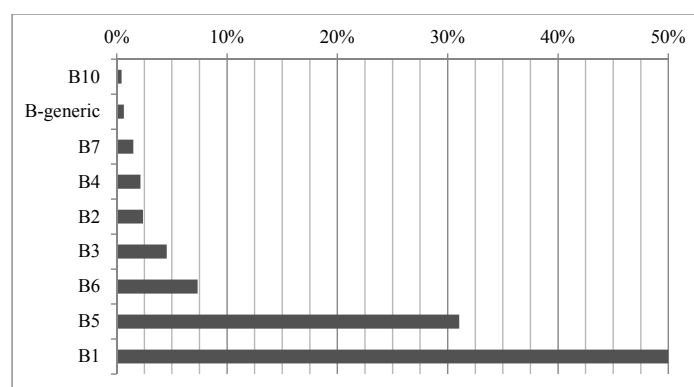


Diagram 20b: Type B-Morphology of bases. Occurrence of main variants – *Bottom-up layout*.

2.2.4._{3,3} Handles and lugs

List of handle and lug types

- H1 – With triangular section
- H2 – With depression at the junction
- H3 – With rectangular section
- H4 – Horizontally disposed and vertically oriented, with triangular profile
- H5 – With double groove
- H6 – With single, central groove
- H7 – Body sherds with handle junction
- H8 – With circular section
- H10 – With rounded section
- H11 – With ellipsoidal section
- H12 – With flattened, large section
- H13 – With squared section
- H14 – Composite, with rounded section
- H15 – Composite, with squared section

¹²¹ Percentages are calculated on a total of 464 diagnostic, recorded bases.

The number of diagnostic potsherds including handles and lugs or a portion of these totals 1042 diagnostic samples, representing an important proportion of the ceramic inventory. The cluster includes rim sherds, body sherds with handle/lug junction and fragments of handles and lugs. The largest section of the inventory relates to body sherds with handle junctions, which represent 15% of the group. Among more specific variants, handles with almost rounded section (circular, mainly rounded or ellipsoidal) (12%-11%) are the most common, followed by handles with a single, central groove (9%), with rectangular (8%) and triangular section (7%), and with triangular profile (6%). Other variants are rarer. Poorly preserved sherds, instead, have been grouped together under the label of generic handles.

H1 – (no. 584) – *With triangular section*. Handles and lugs with triangular section are typically found in red slip ware, although related morphologies are common also in plain ware. More infrequent are brown burnished and yellow slip ware examples. The manufacturing quality varies from medium-fine, usually found in association with the red slip ware, to medium-coarse, more common in plain ware. Although a few specimens are more likely to be associated with the fine ware ceramic production, the functional context of reference is generally that of common ware.

H2 – (no. 585) – *With depression at the junction*. Handles with a rounded depression at the junction with the vessel body are typically found in plain ware, although red slip ware examples are also common. The manufacturing quality ranges from medium to medium-coarse, suggesting that they are related to either the common or the storage ware ceramic horizon.

H3 – (nos 586-589) – *With rectangular section*. Handles with rectangular section are found in different wares: most pertain to the plain ware inventory, but yellow slip, brown burnished, grey and painted ware examples are also well attested. There is marked variability in the fabrics, which range from medium-coarse to fine, relating to either the common or the storage ware ceramic horizon. A few examples in coarse grained, pseudo-brittle and kitchen ware are, instead, more probably to be related to the kitchen ware ceramic horizon.

H4 – (nos 590-593) – *Horizontally disposed and vertically oriented, with triangular profile*. Handles and lugs that are positioned horizontally over the vessel but developed on a vertical plane, usually forming a more or less sharp triangle, are typically found in red slip ware, although a small percentage of plain ware examples are also attested. The manufacture varies from fine to medium: most of the recovered sherds probably relate to the common ware ceramic horizon, but a minority might also be connected with the fine ware ceramic horizon.

H5 – (no. 594) – *With double groove*. Double groove handles are usually found in plain ware. The manufacturing quality ranges from medium-fine to medium-coarse, although the type is most probably related to the common ware ceramic horizon.

H6 – (nos 595-598) – *With single, central groove*. Handles that have a single, central groove are most frequently found in plain ware. Together with a few examples in coarse grained and yellow slip ware, they are characterized by medium-coarse to medium-fine manufacture, and mainly related to the common ware ceramic horizon. A few kitchen ware specimens are, instead, probably to be related to the kitchen ware ceramic horizon.

H7 – (Pl. 16: 1, K08.1590, K08.2048) – *Body sherds with handle junction*. This category comprises body sherds that include the junction with a small section of handle or that bear evident traces of a handle junction, thus supplying only general information. Although most of the examples recovered belong to the plain ware inventory followed by the red slip ware inventory, the group is rather heterogeneous. The manufacture ranges from coarse to fine, and the ceramic horizon of reference includes common, kitchen and fine wares.

H8 – (no. 600) – *With circular section*. The inventory of handles with circular section is very large and heterogeneous. Plain ware examples prevail, but red slip ware specimens are also quite common. Lesser clusters include yellow slip, painted, grey and brown burnished examples. The manufacture is predominantly medium, but finer samples are also common. The functional context of reference includes the common and, to a lesser extent, the fine ware ceramic horizon.

H10 – (nos 599, 601-604) – *With rounded section*. As with the handles with circular section, the group of handles with rounded section is also very large and heterogeneous. Plain and red slip ware examples are the most common, but other classes are also frequent, such as kitchen, yellow slip, brown burnished and painted ware. The manufacture is predominantly medium. The type usually relates to either the common or, more rarely, the kitchen ware ceramic horizon.

H11 – *With ellipsoidal section*. Handles with ellipsoidal section constitute, alongside variants with circular or rounded sections, a very large and heterogeneous group. The majority of the recovered ex-

amples belong to simple wares, such as plain and kitchen ware. Minor clusters include red slip, brown burnished, yellow slip and painted ware examples. The manufacturing quality is primarily medium, related to either the common or the kitchen ware ceramic horizon.

H12 – (no. 605) – *With flattened, large section*. Handles with flattened, large section are typically found in yellow slip and brown burnished ware. The manufacture ranges from medium to medium-fine. Although finer examples are attested, the type mainly relates to the common ware ceramic horizon.

H13 – (no. 606) – *With squared section*. Handles with squared section constitute a small, heterogeneous group. The recovered examples belong primarily to the red slip and grey ware inventory, although sporadic examples are attested in other wares such as painted and coarse grained wares. The manufacture varies from medium-fine to medium, the type being mainly to be related to the common ware ceramic horizon.

H14 – (nos 607-608) – *Composite, with rounded section*. Unusual, composite handles with rounded section constitute a very small, heterogeneous group, to which plain, painted and yellow slip sporadic examples belong. The manufacture is chiefly medium, the type mainly to be related to the common ware ceramic horizon.

H15 – (nos 609) – *Composite, with squared section*. The category of composite handles with squared section refers to a single, sporadic sherd in painted ware. The manufacturing quality is medium, and the piece is generally to be related to the common ware ceramic horizon.

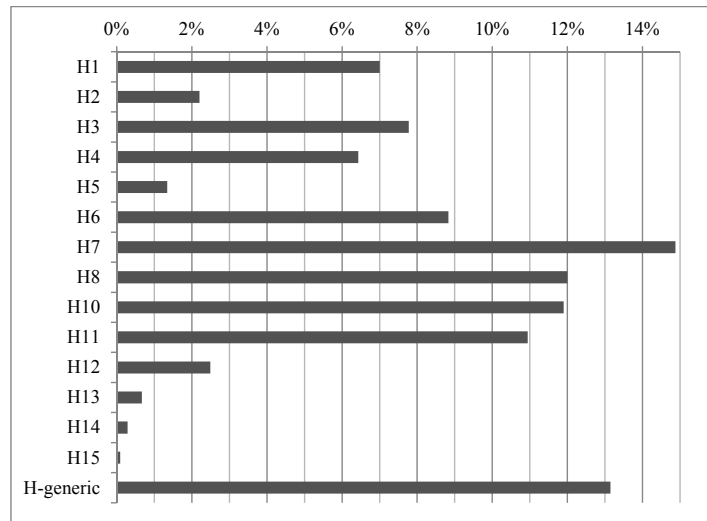


Diagram 21a: Type H-Morphology of handles and lugs. Occurrence of main variants¹²² – Code layout.

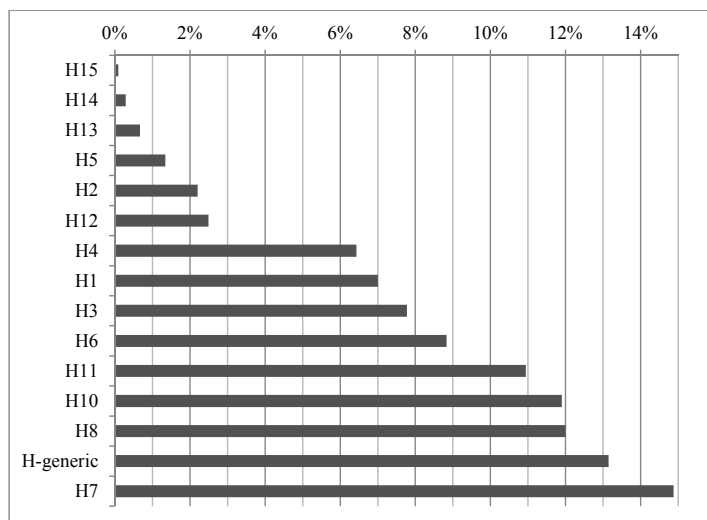


Diagram 21b: Type H-Morphology of handles and lugs. Occurrence of main variants – Bottom-up layout.

¹²² Percentages are calculated on a total of 1042 of diagnostic, recorded handles.

2.2.5 Comparisons and tentative dating¹²³

2.2.5.1 The earlier phases of occupation: from the faint traces of Late Chalcolithic to evidence of the Early Bronze Age/Middle Bronze Age transition

The remains of the Chalcolithic and Early Bronze Age periods on the northern portion of the Central Anatolian Plateau have been disregarded by researches in the field, and a very limited number of projects concentrating on this broad chronological range furnish only sparse clues which are, however, useful in providing a fragmented understanding of the ancient occupation. One of the reasons for this state of affairs in research is the reduced visibility of sites dating to the pre-Bronze Age due to a variety of probable causes: natural erosion that probably cancelled the traces of an earlier settlement, inevitably of small size, relatively short lived and often not mounded; the accumulation of later archaeological deposits on top of them, thus obscuring any archaeological remains dating to the earlier periods; the different aspect of the landscapes at that time, probably densely forested and, consequently, not very attractive for earlier farmers (Schoop 2005a), apart from limited clearings near the valleys or along the rivers; and, lastly, our inability to recognise archaeological markers (Summers 2002). A part from this, such a state of things indicates a truly grey area in the archaeological research only partially clarified by some scattered evidence which, however, is too limited even to enable us to identify any clear connections and cross-cultural comparisons between the different pottery assemblages. It is also insufficient to be able to sketch a general sequence of the materials or the development of local cultures from a long-term perspective.

As things stand, for the area of the Northern Central Plateau, sites such as Boğazköy, Alişar Höyük, Çadır Höyük, Alaça Höyük and Mercimektepe are point of reference shedding light on the 4th-3rd millennium settlement and contextual ceramic traditions. In particular, Çadır offers a good sequence that contributes substantially towards bridging the gap left by the potential lack of evidence related to the Late Chalcolithic period and beginning of the Early Bronze Age (hereinafter EBA), in the area east of the Konya plain (Steadmann *et al.* 2008). The evidence from Boğazköy and the excavations of Mercimektepe allow us to outline the development of the ceramic tradition during the EBA, together with the data coming from earlier work carried out at Alişar, in the first part of twentieth century.

The handmade assemblage found at Uşaklı is characterised by sherds, with medium-fine and coarse fabrics, mineral and vegetal inclusions whilst the surface can be untreated, slipped or burnished and painted (wares P-Hm, Rs-Hm, Pt-Hm, C). The first impression is that we have a composite repertoire of monochrome common and painted/slipped wares belonging to the EBA tradition and the passage from EBA to Middle Bronze Age period, but in the absence of ornamentation we are unable to propose more defined categories for different periods solely on the basis of fabrics and surfaces treatments. In other terms we date the painted sherds to the transition between EBA and Middle Bronze Age (hereinafter MBA) thanks to parallels with other sites but we do not know, for example, if the burnished surfaces are more recent than the untreated surfaces or whether the more chaffy sherds are contemporary with the sandy tempers. This is mainly due to different factors such as the scarce number of sherds collected, the very limited number of sites investigated to date, their limited exposure as well as the absence of a EBA key sequence in the region with which to draw comparisons.

Particularly hard to determine in chronological terms are some small groups of handmade sherds without painted decorated motifs. The repertoire is small and the state of preservation of the individual fragments is very poor but nevertheless shall attempt to give a general overview and evaluation of the few diagnostic types identified. A group of plain ware sherds (P-Hm) with simple rims (some specimens in Pl. 15: 5, top line, second sherd on the left, not numbered; K09.1208; K09.1169; K08.1886; K08.1796; 15: 9, K08.1931), made from reddish-brown plant-tempered clay, have the surface untreated or only summarily smoothed or burnished. The texture is from medium to coarse. Also a certain number of untreated specimens with mineral and/or chaff inclusions have been found. In general, simple forms of conical bowls with simple rims are prevalent and recurred over a long chronological range, from the Chalcolithic period onwards¹²⁴. At first glance, our handmade potsherds do not appear to have the characteristics of the typical Chalcolithic production, mainly mineral tempered and black/grey in colour (Schoop 2011a: 156, 163).

¹²³ In order to make it easier the reading of the text, bibliographic references for comparisons of ceramic types are in the footnotes.

¹²⁴ See for example Büyükkaya, probably dating to the first half of 6th millennium BC in Schoop 2005a: 50-56, 343, for the earlier specimens showing these morphological characteristics.

In fact our repertoire is defined mainly by handmade red slipped sherds (ware Rs-Hm) or reddish/brown tempers, with grey/dark core; the slip is in some cases thick, burnished, in others mat and faint. This is the first important marker in assign an approximate date to our repertoire, focusing on some periods rather than others. The rare occurrence of the red slip treatment in Büyükkaya, attested by the rare 'rotschwarzer' group, is considered a possible link with the Alişar IV Copper Age assemblage (Parzinger 1993: 213; Hachmann 1957: 61). This assemblage, assigned at first to the Copper Age by H. H. Von der Osten (1937, 110) has to be considered, in the light of current studies, as a post-Chalcolithic phase of the settlement occupation, contextual to a change in the local ceramic tradition (Schoop 2011a: 163-164; Steadmann 2011: 242-244). Although the transition between the end of the Late Chalcolithic and the beginning of EBA is still not clear and subject to debate (Steadmann 2001: 229; Schoop 2011a: 163-165), the EBA horizon seems to offer the best comparison for our repertoire. In effect, the red slip is a treatment considered characteristic of this period, becoming particularly popular from the end of EBA Ib to the transitional period (Orthmann 1963b: 17; Koşay, Akok 1957: 34; 1951: 182).

Bowls with dark brown/blackish outer surface, red rim and red inner side (Pl. 15: 8, K12.1092, K12.135) may be part of an earlier EBA horizon. The dark colour is a feature attested also in the previous period. Effectively, the assemblage of Yarikkaya, 2km NE of Büyükkaya, dating probably to the Late Chalcolithic, is composed mainly of mineral and plant tempered sherds with polished surfaces, usually black on the inner side although beige or red colours are also attested. In particular, the use of red colour on the inner wall and outer portion of the rim has been documented within the repertoire of the site (Schoop 2005b: 60). We could tentatively assign to the earlier phases of occupation the fragment of red slipped jar with flaring neck and everted rim no. 674 (Fig. 35), similar to a type found in Alişar, dating to the EBA I¹²⁵. No. 686 recalls a carinated bowl type found in Boğazköy level 8b¹²⁶.

The body sherd with knobbed decoration (Fig. 34: 641; Pl. 15: 6) has parallels in particular with the Büyük Güllücek repertoire¹²⁷ and vaguely recalls a decorative pattern documented at Alaça, but wavy and located on the rim, dating to the beginning of EBA¹²⁸; and Boğazköy, in the assemblage dating to the EBA-MBA transition¹²⁹. The presence of the sherd with knobbed decoration could perhaps be the first evidence of a late Chalcolithic/beginning of Early Bronze Age phase at the site.

The hill of Mercimektepe, on the eastern outskirts of Yozgat, where a series of trenches have been opened, revealed a few remains of stone and mud brick wall and ash pits, together with a painted pottery assemblage dating to the final phase of the EBA period (Zoroğlu 1977; Özcan 1993). This repertoire offers some useful elements for comparisons. From the trench Ç, on the western slope, painted pottery of the so-called 'Intermediate style' in general is decorated by spaced, horizontal lines framing oblique or vertical/oblique lines starting from the top. In a couple of cases the pattern of our painted sherds, such as no. 680 (Fig. 35) recalls the geometrical style with horizontal and vertical parallel lines found in Mercimektepe¹³⁰.

Most of our specimens find good parallels with the repertoire of the EBA-MBA transition. However, for this period, encompassing roughly the final phases of the 3rd and the beginning of the 2nd millennium, we still have a very incomplete picture of the region within the Kızılırmak bend which means that neither the chronological framework nor the basic pottery sequences have yet been identified with any accuracy. This long period, the limits of which are not yet well defined, shows the co-existence of handmade and wheelmade forms, both monochrome and painted. The pottery tradition is conservative and many types remain unchanged at the turn of 2nd millennium BC. The most characteristic ware of the transition is the so-called painted 'Intermediate' or 'Cappadocian' ware (ware C), the Alişar III style pottery (Schmidt 1932: 194-202; Gorny *et al.* 1995: 78-79; Steadmann 2011: 246, 251), particularly diagnostic and easily recognisable also within materials gathered during the survey. It is a handmade production, generally tempered with organic and mineral inclusions, with a medium-fine to coarse texture. The painted patterns include bands, chevrons, and wavy and zig-zag lines. This production is of the EBA tradition and is to be related, in some way, with the earlier production of painted wares from the previous phases of the Bronze Age, with which it shares geometric decorated pattern and shapes. In fact stratified contexts dating to this period are very scarce. The north-western

¹²⁵ Orthmann 1963b: taf. 7: 2/32; Von der Osten 1937a: fig. 73 and 109.

¹²⁶ Orthmann 1963a: taf. 32: 316.

¹²⁷ Koşay, Akok 1957: Lev. XVIII: 1, lower line.

¹²⁸ Koşay, Akok 1951: Fig. 26.

¹²⁹ Orthmann 1963: taf. 16: 159.

¹³⁰ Özcan 1993: Fig. 12.

slope of Boğazköy offers remains of the EBA-MBA transition level (Orthmann 1963a; 1963b: 43). Layer 9, which consists of fire destruction debris above the natural soil and dates to the transitional period, and layer 8 with relics of a few walls, dating to the Old Hittite period, furnished a repertoire which can usefully be compared with our materials, including the following wares (Orthmann 1963b: 13): hand-made monochrome, 'Cappadocian' painted, wheelmade fine plain, wheelmade and hand finished. The Cappadocian painted sherds show usually oblique and horizontal patterns (Orthmann 1963: taf. 10: 52-54, 67), whilst complex patterns occur only rarely. In general simple patterns of painted decoration and fine sandy fabrics have been considered as traits of the earlier date of the Boğazköy repertoire as compared with Alişar and Kültepe (Orthmann 1963a, 23) which belong to a later group of this painted production and are characterised also by different fabrics. In any case the development of the pottery tradition throughout these centuries is continuous and without significant change.

The handmade ware sherds from Uşaklı belong to open and closed shapes probably dating to different periods within the large chronological range encompassing the EBA and the EBA-MBA transition. In fact, on close inspection we seem not to be dealing here with a single manufacture. Finer specimens are documented, but the decoration patterns are not dissimilar from the coarser fragments. Some painted sherds (Fig. 35: 677-686; Pl. 15: 1-3) have geometric patterns, with parallel horizontal and broken lines, while others have more complex patterns; only a fragment (Fig. 35: 684; Pl. 15: K10.156) is decorated with two colours, red and dark grey but not in whitish shade as documented in Alişar (Schmidt 1932, 201) and in one case in Boğazköy. In some cases the variation in the colours of the surface slip and painted decoration that include nuances towards violet and white (Pl. 15, 1: K09.54, K08.2203, K10.101, K09.1212), displaying certain traits of the 'Intermediate ware' horizon (Von der Osten 1937a: 231; fig. 235, 7), made us suspect that a different and earlier phase of the Cappadocian ware production could be attested.

In this case, the body sherds where the geometric painted motifs are often positioned are easy to identify also in the course of the surface surveys. The pattern of vertical irregular lines on the shoulder of a closed form that we found (Pl. 15, 1: K10.101) is documented at Alaça, but with a more widely-spaced motif¹³¹; at Çiradere with a slightly oblique direction¹³² and in part also at Büyükkale¹³³. The linear painted pattern of no. 685 and no. 681 (Pl. 15: 1) recurs within the typical Cappadocian assemblage and is similar, for instance, to the upper wall decoration and rim of types found at Boğazköy, in the recent phases of the sequence, i.e. levels 8b and c-d, dating to the Old Hittite period¹³⁴; at Alaça¹³⁵; in the recent EBA of Kültepe¹³⁶; at Alişar¹³⁷ and at Battal¹³⁸. The decoration pattern of no. 682 shows similarities with specimens from Boğazköy¹³⁹ and Çiradere¹⁴⁰. The design organised in metopes separated by bands, characteristic of the Alişar assemblage, is also attested among our specimens (Fig. 35: 683; Pl. 15: 1, K08.382).

Recurring open forms include curved bowls (Fig. 35: 643-651), types with inturned upper side (Fig. 35: 653-657) and possible deep bowls with upright or, more often, sinuous sides (Fig. 35: 658-661). Simple curved bowls are attested in Boğazköy level 9¹⁴¹ and in Büyükkale pre-Hittite period¹⁴², together with types characterised by inturned side¹⁴³, while bowls with horizontal handle (Fig. 6: 121-122), triangular or curved, probably belong to the same horizon. Bowls with the upper portion of the wall curved inward, or a kind of hole-mouth bowls, intermediate between open and closed shapes and classified as type 2B.4 (Fig. 35: 655-657), find parallels in Boğazköy, north-western slope level 9 and 8¹⁴⁴; and show partial similarities also with some hole-mouth pots¹⁴⁵. The curved crescent shaped lug of no. 653 finds

¹³¹ Öktü 1973: taf. 39: III-G/01.

¹³² Öktü 1973: taf. 51, VI/29, VI/31.

¹³³ Fischer 1963: taf. 3: 32, but thinner lines.

¹³⁴ Orthmann 1963a: taf. 33: 338; taf. 23: 221; Fischer 1963: taf. 1: 13.

¹³⁵ Koşay, Akok 1966: lev. 24: k 152.

¹³⁶ Orthmann 1963b: taf. 1: 1/12.

¹³⁷ Von der Osten 1937a: Fig. 267: 8; Fig. 258: 5; 259: 3, 5, 8 and used as module of the complex pattern in Fig. 262: 13.

¹³⁸ Von der Osten 1929: 93; Orthmann 1963b: taf. 87: 29/12.

¹³⁹ Orthmann 1963b: taf. 87: 29/1.

¹⁴⁰ Öktü 1973: taf. 52, VI/32.

¹⁴¹ Orthmann 1963: taf. 10: 56.

¹⁴² Fischer 1963: taf. 5: 63.

¹⁴³ Orthmann 1963: taf. 10: 54, 53, 57.

¹⁴⁴ Orthmann 1963: taf. 12: 99 for our no. 655; taf. 11: 82; taf. 15: 149-152.

¹⁴⁵ Orthmann 1963: taf. 20: 179-182.

parallel in the earlier assemblage of the lower city of Boğazköy¹⁴⁶. It is difficult to assign the unique case of a plate with short side (Fig. 35: 642) firmly to the earlier periods because similar handmade types are documented also in the subsequent Late Bronze Age and Iron Age levels¹⁴⁷.

Deep bowls with sinuous upper sides, type 2C.x (Fig. 35: 659-661) and short necked jars such as our nos 667-668 apparently find no comparisons with the Boğazköy repertoire quoted here, but do recall the shape of a painted jar rim from Alaça¹⁴⁸. Among these there is a sherd (Fig. 35: 659; Pl. 15: 10, K09.1020) which has a whitish slip and a red/orange core. Whether these elements are part of an earlier assemblage is, unfortunately, a question that must remain unanswered for the moment as our collection is from surface rather than stratified contexts. At the same time the absence from our collection of bowls with slightly outwardly flaring rims which are, instead, documented in the pre-Hittite levels at Büyükkale¹⁴⁹ recurring in level 9 and then in level 8c-d¹⁵⁰ and in the old *karum* period, level 8b¹⁵¹, could suggest further clues for differentiation but could, equally, be merely accidental.

As far as for closed shape concerns, the rims of short-necked jars are often painted, with a band overlapping on either the interior side (Fig. 35: 672-673) or on both the interior and exterior (Pl. 15: 1, K12.1268). This characteristic appears in the north-western slope of Boğazköy, level 9¹⁵², and in the lower city¹⁵³ dating to the late *karum* and Old Hittite period, level IV and IVc and IVd. To conclude, some general remarks about two types of closed forms: short-necked jars similar to our no. 672 are documented at Boğazköy but with lightly different rim end¹⁵⁴; hole-mouth bowls/pots of type 5A (Fig. 35: 662-666) belong to a category of vessels used for a long period, and are attested, for example, in the Alaça EBA level¹⁵⁵.

2.2.5.₂ The 2nd millennium BC occupation, between the *karum* and Hittite periods

As regards the 2nd millennium BC, the key sites used as best comparisons in our attempt to assign a preliminary date to the Uşaklı ceramic repertoire are mainly Boğazköy, Kuşaklı and Kaman-Kalehöyük. In particular, layers 3 and 2 of the building on the west slope of Kuşaklı, dating between the end of the Old Kingdom and the Middle Kingdom (Mielke 2006: 170), the built-up areas on Büyükkale and the lower city of Boğazköy (Fischer 1963; Schirmer 1969), dating from the *karum* period through the Old Hittite to the Imperial period provide us with sequences which encompass most of the 2nd millennium BC. Instead, the lower city of Boğazköy, the temple central district (Parzinger, Sanz 1992), dating from the the end of 13th century BC to the beginning of 12th century BC, the quarter of the kilns in the upper city (Müller-Karpe 1988) and the contemporary level of Kaman-Kalehöyük (Matsumura 2005: 40, 529) provide further good repertoires for the Hittite and Imperial periods.

Several specimens in wheelmade plain and red slipped wares could date to the 2nd millennium BC. Our repertoire includes many types of mass-produced wheelmade plain ware with profiles and treatments characteristic of the Late Empire production (ware D). Often scraping and trimming marks are visible on the external wall of the side, the result of the removal of excess clay from the surfaces. These types probably continued to be produced also during the first part of the Early Iron Age (hereinafter EIA), as documented for example in Büyükkaya (Schoop 2003; Genz 2004: 24) and only gradually began to be substituted by new products and manufacturing techniques. On the contrary, no handmade or painted sherds similar to those found in Boğazköy and dating to the EIA (Genz 2003 and 2004: 24-28) have been recovered during the surveying activities at Uşaklı. Another well-documented surface find is red slipped ware (Rs), characterised by a red to reddish/brown smoothed and burnished slip which covers both the exterior and interior surfaces which can also be lustrous. The distribution of red-slipped sherds is homogeneous and covers wide sectors of the terrace. We do not seem to be dealing here with a single traditions and there are serious limitations to the reliability of this ware as a

¹⁴⁶ Fischer 1963, taf. 6: 71.

¹⁴⁷ See, for example, similar type of plates dating to the Hittite period in Matsumura 2005: taf. 34; taf. 105; Mielke 2006: 126-127: type Te 2.

¹⁴⁸ Koşay, Akok 1973: Lev. LXXVIII: Al. R. 234.

¹⁴⁹ Orthmann 1963b: taf. 8: 23-26; taf. 17: 17-19, 28; Fischer 1963: taf. 6 and 10.

¹⁵⁰ Orthmann 1963b: taf. 21: 187-193, 198-200.

¹⁵¹ Orthmann 1963b: taf. 31: 283-284, 289, 296.

¹⁵² Orthmann 1963a: taf. 10: 63; taf. 18: 69.

¹⁵³ Fischer 1963: taf. 55: 532; taf. 57: 510; taf. 58: 538.

¹⁵⁴ Orthmann 1963a: taf. 23: 213, 214.

¹⁵⁵ Koşay, Akok 1973: Lev. LXXVIII: Al. R. 246.

marker for purely second millennium occupation since it is also documented for the Iron Age. Many diagnostic specimens are, in fact, more probably to be dated to the MBA or Late Bronze Age (hereinafter LBA), offering at least parallels with stratified contexts.

Plates, shallow conical and flaring bowls ascribable to types 1A-H (Figs 1-2) date, in most cases, to LBA¹⁵⁶. Usually the large sized types are characterised by simple rims or inner thickened rims variously shaped, and in some cases by a sort of inner large ribbon-like thickening that outlines the end portion of the side. Plates and shallow bowls with simple rim (type 1A.1; Fig. 1: 1-3), generally rounded, are also attested in the above mentioned sites¹⁵⁷, as well as specimens with inner round thickened rim, listed as type 1H.2-3¹⁵⁸. These types date from the early Hittite period up to the Late Empire¹⁵⁹, being produced from the 17th to the 13th century BC, with a peak in the 15th century BC. A typical element associated with the large plates is the rope imprint along the external portion of the rim (Fig. 2: 22-28; Pl. 19) or, in certain cases, on the exterior upper side, a mark of the characteristic manufacturing process. The characteristic plate of LBA date is scattered over a wide geographical area and documented farther afield at some sites on the edges of the territory controlled by the Hittites, for example in Porsuk¹⁶⁰ and Kinet Höyük¹⁶¹ to mention only a couple. Also conical bowls with inside thickened rim and less flared sides, classified as type 2A.9 (Fig. 4: 84 and 86) show a certain similarity with specimens from these same sites¹⁶². Small plates of type 1J.1 (Fig. 2: 34-35) can also be assigned to the same period on the basis of parallels with Kuşaklı¹⁶³.

Many curved bowls classified as types 2A.1, 2A.4, 2A.9, 2A.18, 2B.17-18, some in drab ware and others in plain ware (Pl. 18¹⁶⁴), generally buff to brown in colour, constitute our characteristic repertoire of probable Hittite date. They share with the repertoire of plates and shallow bowls the rough surface finish that retains many traces of their shaping (signs, defects, clay lumps, lines of the manufacturing from the potter's wheel).

Several types of bowls in plain and slipped wares bear similarity with the repertoire of Boğazköy dating to the Hittite period. To give just a general framework of comparisons, types 2A.2a and 2A.2b, 2d (Fig. 3: 51-57, 59-60) and types 2A.3a, 3b, 4a (Fig. 3: 63-68) show profiles similar to round bowls from Büyükkale as well as from the lower and upper cities of Boğazköy¹⁶⁵. In particular, some shapes such as nos 53-55 and nos 59, 60, 55 with short upright rim, find more close parallels¹⁶⁶.

Hemispheric thin walled bowls, with simple and pointed rims, classified as types 2A.2 and 2A.3 (Fig. 3: 39, 48-55, 58-64) find parallels in Kuşaklı¹⁶⁷ and Boğazköy¹⁶⁸, and nos 48-49 and specimens with pointed rim in the Kaman-Kalehöyük level dating to the Imperial period¹⁶⁹.

With regard to other middle-sized conical bowls, type 2A.4a (Figs 3-4: 68-71) and 2A.4d (Fig. 4: 74, 76) general parallels to LBA contexts have also been found¹⁷⁰; as well as for type 2A.4b (Fig. 4, 72¹⁷¹).

Shallow bowls types 2A.10-13 present peculiar rims vaguely in the shape of a goose beak. Type 2A.10 (Fig. 5: 87) and types 2A.11a-c (Fig. 5: 90, 95, 96, 99) find parallels respectively in Kuşaklı and in the lower city of Boğazköy¹⁷². From type 2A.11c to 2A.14b (Fig. 5: 95-111) comparisons are with Kuşaklı¹⁷³

¹⁵⁶ Fischer 1963: taf. 100-101; Parzinger, Sanz 1992: 29: type J; Müller-Karpe 1988: types S2a, Te1a-T2b; Mielke 2006: taf. 69-73; taf. 88-89.

¹⁵⁷ Fischer 1963: taf. 94: 857; Müller-Karpe 1988: taf. 32: type S2a; Matsumura 2005: taf. 19: KL96-M80.

¹⁵⁸ Fig. 2: 30-32; cfr. Mielke 2006: taf. 49: 12.

¹⁵⁹ Mielke 2006: 134 and footnote no. 506 for comparisons.

¹⁶⁰ Dupré 1983: Pl. 20-21.

¹⁶¹ Gates 2006: Fig. 10: 4.

¹⁶² Mielke 2006: taf. 49: 6; Matsumura 2005: taf. 55: KL94-M148; Parzinger, Sanz 1992: 27: type I 3,1 c; Müller-Karpe 1988: taf. 29: type S1a.

¹⁶³ Mielke 2006: taf. 57: 28.

¹⁶⁴ See description of sherds in tables of figures.

¹⁶⁵ Fischer 1963: tav. 83; taf. 88: 769, 766; taf. 87: 750, 753; Müller-Karpe 1988: taf. 40: type S12a.

¹⁶⁶ See respectively Fischer 1963: taf. 83: 696-698, 693, 700, 689; taf. 83: 100.

¹⁶⁷ Mielke 2006: taf. 57: 1-19, 23-24, 42; taf. 58.

¹⁶⁸ Fischer 1963: taf. 88: 769, 760.

¹⁶⁹ Matsumura 2005: taf. 1: KL95-M332, M488; taf. 11.

¹⁷⁰ Mielke 2006: taf. 54: 2, 27-30; Fisher 1963: taf. 86: 744; taf. 84: 709, 707, 710; taf. 83: 691; taf. 89: 782; Matsumura 2005: taf. 2: KL95-M402 for the incurved rim; Mielke 2006: taf. 53: 23.

¹⁷¹ See Fischer 1963: taf. 86: 744.

¹⁷² Mielke 2006: taf. 55: 27; Parzinger, Sanz 1992: taf. 11: 1; taf. 11: 7-15.

¹⁷³ Mielke 2006: taf. 53; taf. 59: 9-21; Müller-Karpe 1988: taf. 34-37: types S4c-S50.

and partially Kaman-Kalehöyük¹⁷⁴. In particular, we can relate to the repertoires of the above-mentioned sites our specimens nos 97-98¹⁷⁵; type 2A.13 (Fig. 5: 107)¹⁷⁶; type 2A.14a with inner and outer thickened rims (Fig. 5: 108-110 and 111-113)¹⁷⁷, and types 2A.14d-e (Fig. 6: 114-115)¹⁷⁸ which persist also in the Iron Age repertoire (see below the section on the Iron Age - hereinafter IA).

Shallow medium and large sized bowls, type 2A.18a (Fig. 6 and 7) and, in particular, examples such as nos 138-139, represent a category that is morphologically so close to certain kinds of plates (i.e. types 1H.2-3, Fig. 2) that it is difficult to establish clear distinctions purely on the basis of proportion and size ratios apart from the general observation that plates have more pronounced flaring edges and rims. Parallels of variant no. 139 (Fig. 6) are to be found at Kuşaklı and Boğazköy¹⁷⁹. No. 141 (Fig. 7) and no. 147, type 2A.18c (Fig. 7) are characterised by a vertical end and lightly in-thickened rim documented also in Boğazköy¹⁸⁰, but apparently with no superficial irregularities on the inner side of the rim, as a kind of narrow parallel lines and grooves left during the manufacturing phase. The light depression under the rim of type 2A.18b (Fig. 7: 144-145) is a characteristic documented in some specimens found at Boğazköy¹⁸¹, but belonging to different forms.

For type 2A.19a-b (Fig. 7: 157-161) the sites of Kaman-Kalehöyük, Kuşaklı and Boğazköy once again provide good parallels¹⁸², whereas type 2A.18e, no. 153 shows only a generic similarity¹⁸³. Type 2A.24 (Fig. 9: 200) recalls the rim of a specimen found at Kaman-Kalehöyük, but small in size¹⁸⁴. The shape of no. 213, type 2A.29b (Fig. 10), is documented also in Kaman-Kalehöyük from the end of LBA to the Middle Iron Age¹⁸⁵. The size and shape of no. 220 (Fig. 10) are vaguely reminiscent of a specimen from the same site¹⁸⁶, but not in grey ware.

The carinated bowls with thin walls are generally to be considered as dating to the IA. In a limited number of cases some elements can be found starting from the end of 2nd millennium BC. Within type 2B.1 (Fig. 10), S-shaped fine bowl no. 233 could recall a specimen found in Kuşaklı¹⁸⁷ but with a rectilinear external profile. It is quite probable that type 2B.2a (Fig. 10: 235) should be dated to LBA on the basis of parallel found in Kuşaklı¹⁸⁸, and no. 234 is similar to some smaller, carinated examples¹⁸⁹.

Small carinated bowls with everted flaring side and simple or pointed rim, our type 2B.1 (Fig. 10) cannot be assigned to any precise period. In some cases, like the Gold Wash ware specimens (Fig. 10: 223-225), and in part also 226, the general shape recalls types found at Boğazköy¹⁹⁰, as well as the rim of nos 230 and 231¹⁹¹.

Carinated bowls with inturned side and V-shaped handle, types 2B.4a and 2B.4b (Fig. 11: 256-273; Pl. 16: 1), mainly but not exclusively in red slip ware, often date to the Old Kingdom period, continuing a characteristic production of the *karum* period but documented up to the end of the LBA¹⁹². Similar shapes have been found in the Hittite level of Alişar¹⁹³. Parallels for our specimens characterised by the curved profile of the upper sides and simple rim, in some cases with the inner portion lightly enlarged,

¹⁷⁴ Matsumura 2005: taf. 18: KL95-M407 and 492.

¹⁷⁵ See Matsumura 2005: taf. 3: KL96-M42; Parzinger, Sanz 1992: taf. 37: 17.

¹⁷⁶ See Parzinger, Sanz 1992: taf. 47: 4.

¹⁷⁷ See Matsumura 2005: taf. 13: first seven specimens; taf. 18: KL95-M440; Parzinger, Sanz 1992: taf. 15: 1-13; Müller-Karpe 1988: taf. 35: type S5e-f; taf. 36: type S5i.

¹⁷⁸ See Mielke 2006: taf. 50: 18 and 4; Parzinger, Sanz 1992: taf. 5: 18.

¹⁷⁹ Mielke 2006: taf. 49: 20; Fischer 1963: taf. 91: 805, 804.

¹⁸⁰ Fischer 1963: taf. 88: 764.

¹⁸¹ Fischer 1963: taf. 94: 854; taf. 96: 876.

¹⁸² Matsumura 2005: taf. 13: KL95-M462, M44, M103; taf. 16; taf. 55: KL94-M182 and for the rim M438; Parzinger, Sanz 1992: 27: type I 3.1.b.

¹⁸³ Matsumura 2005: taf. 55: KL94-M182.

¹⁸⁴ Matsumura 2005: taf. 3: KL94-M81.

¹⁸⁵ Matsumura 2005: taf. 36: KL89-M51; in part taf. 50, KL98-M96; taf. 108: KL89-M198.

¹⁸⁶ Matsumura 2005: taf. 52: KL93-M101.

¹⁸⁷ Mielke 2006: taf. 59: 11.

¹⁸⁸ Mielke 2006: taf. 56: 19, 20.

¹⁸⁹ Mielke 2006: taf. 56: 25-27; Matsumura 2005: taf. 4: KL94-M56.

¹⁹⁰ Fischer 1963: taf. 98: 899, 897, 898, 895.

¹⁹¹ Fischer 1963: taf. 98: 887 e 888.

¹⁹² Schoop 2009: 151; Mielke 2006: 149, 123; Matsumura 2005, 305: KL96-M51.

¹⁹³ Von der Osten 1937b: fig. 219-220.

are to be found at Kaman-Kalehöyük¹⁹⁴. Bowls of this kind with simple rim or out thickened rim and moderate size are documented for example in Boğazköy, sometimes with longer sides¹⁹⁵. Some specimens with slightly thickened outer rim, type 2B.7c, like nos 293-294 (Fig. 12) or type 2C.2, nos 341-343 (Fig. 15), recur within the MBA horizon of Kültepe¹⁹⁶; and no. 342 finds parallels also in Boğazköy¹⁹⁷. The large, deep bowls with V-shaped handles, type 2C.2 (Fig. 15: 341-343), are also documented at Boğazköy¹⁹⁸.

Some of the bowls with the rim curved inward (Fig. 12: 281, 279, 282) are characteristic of the LBA horizon¹⁹⁹. The bowl type with everted rim (Fig. 12: 290) is attested at Boğazköy²⁰⁰, Kaman-Kalehöyük²⁰¹ and at Kültepe²⁰², whilst no. 292 recalls a type found at Kuşaklı²⁰³. The thin walled specimen no. 301 is part of the Kaman-Kalehöyük repertoire of LBA date²⁰⁴.

In general carinated bowls are dated from the *karum* to the end of the Empire period (Mielke 2006, 111) and then to the IA. Some of them with upright sides and outer thickened rim find parallels within LBA contexts. No. 315 (Fig. 13) bears some similarities to shapes found at Kaman-Kalehöyük, often partially red painted/slipped like our nos 318-320²⁰⁵. The medium to large sized carinated bowls classified as types 2B.17 and IIB.18 are part of medium/coarse production of probable LBA date, sharing fabrics, surface colours and treatments with our drab ware curved bowls and plates. A generic parallel has been found with materials from Kuşaklı²⁰⁶, which are slightly more flared; Boğazköy²⁰⁷; Kaman-Kalehöyük²⁰⁸ or from level V of Porsuk²⁰⁹. It is noteworthy that their scatter overlaps that of characteristic drab ware sherds (see chapter on the distribution of the main types below).

Among closed shapes (Figs. 19 and 20), the necked jars ascribable to the 2nd millennium are very hard to isolate on the basis only of a limited portion of rim. In general the shape is generic, morphologically poorly specialised and the type was produced over a long period of time. Consequently, the rim could often be part of a LBA assemblage, but we cannot exclude an MBA or IA date.

Comparison for the small jars are few and for those classified as type 3A.1 (Fig. 16: 345-354) some can be found in Kaman-Kalehöyük²¹⁰.

Kitchen pots, jars without neck or with only sketchy/short neck (Figs. 17-18), often with out thickened rounded rim, represent a group with good parallels in the Hittite period repertoire of Kuşaklı and Boğazköy²¹¹. Type 6A.6 (Fig. 17: 378-380, 382), but also type 5A.5 (Fig. 17: 376) and type 5A.7 (Fig. 18: 383-384) recall specimens found in Boğazköy²¹² and Kaman-Kalehöyük²¹³ as well as no. 392²¹⁴. Type 5A.11 is documented in the lower city of Boğazköy²¹⁵. A part two specimens from Boğazköy²¹⁶, it is more problematic to find parallels for the type 5A.8b (Fig. 18: 387-389) characterised by a ridge on the shoulder.

The general shape of high necked jars, types 6C.2-4 (Fig. 20: 432-443) resembles specimens found at Kuşaklı and Kaman-Kalehöyük²¹⁷; for 6C.2 (nos 432, 434-436) parallels are found at Boğazköy²¹⁸.

¹⁹⁴ Matsumura 2005: taf. 4.

¹⁹⁵ Fischer 1963: taf. 104: 961, 967, 948; and in general taf. 104-108; Schirmer 1969: taf. 24, 28, 32-33.

¹⁹⁶ Özgüç 1999: Fig. B.1-26.

¹⁹⁷ Schirmer 1969: taf. 25: 37.

¹⁹⁸ Fischer 1963: taf. 106: 945, 946; taf. 108: 966.

¹⁹⁹ Fischer 1963: taf. 85: 732; Mielke 2006: taf. 58: 40; Fischer 1963: taf. 84: 709, 707.

²⁰⁰ Parzinger, Sanz 1992: taf. 46: 23, 24; but also Orthmann 1963: taf. 30: 278-279 dating to the old *karum* period.

²⁰¹ Matsumura 2005: taf. 6: KL92-M165.

²⁰² Özgüç 1999: şek. B: 67-68.

²⁰³ Mielke 2006: taf. 56: 16.

²⁰⁴ Matsumura 2005: taf. 6: KL92-M165 e M180; taf. 8: KL96-M78.

²⁰⁵ Matsumura 2005: taf. 5; taf. 6: KL96-M120.

²⁰⁶ Mielke 2006: taf. 61: 10, 2; 1-10; taf. 27: 1 for pronounced carination.

²⁰⁷ Fischer 1963: taf. 110, 112.

²⁰⁸ Matsumura 2005: pl. 7: KL94-M72.

²⁰⁹ Dupré 1983: pl. 19: 113-116.

²¹⁰ Matsumura 2005: taf. 61: first five specimens.

²¹¹ Mielke 2006: taf. 14-16; Müller-Karpe 1988: taf. 9-11.

²¹² Fischer 1963: taf. 51: 500; taf. 52: 577, 574, 579, 501, 502.

²¹³ Matsumura 2005: taf. 21-25.

²¹⁴ Matsumura 2005: taf. 41: KL88-M1264.

²¹⁵ Parzinger, Sanz 1992: taf. 1: 1.

²¹⁶ Parzinger, Sanz 1992: taf. 2: 6, 7.

²¹⁷ Matsumura 2005: taf. 30-31.

²¹⁸ Müller-Karpe 1988: taf. 3-7.

Within type 6D are classified the fragments of beak spouted jars that were produced from the beginning of EBA/MBA transition up until the LBA. In particular for no. 460 Boğazköy shows good parallels²¹⁹.

Series of fragments in plain or slip wares classified as types ZA can be assigned to craters, funnel-shaped and large sized jars dating from the *karum* period to the IA. Specimens with ledged squared rim and inside stepped for supporting lids (Fig. 26: 510-511) or outer thickened oval rim and vertical neck (Fig. 26: 495-497 and 506) could be of Hittite date²²⁰ and the same applies also to no. 507²²¹. In Kuşaklı the majority has simple rim, like our nos 494-497²²², nos 506-507²²³ and lid support ledge is poorly documented. The slight swelling under the rim of no. 501 (Fig. 26) recalls a characteristic documented in type 15 of the Kuşaklı typology²²⁴.

Only a few storage jars fragments can be firmly dated to the LBA period. This category of container was in use for a long time and the formal characteristics show few variations over the different periods (Figs 22-25). The specimen of large storage jar with button-like application (Fig. 23: 479; Pl. 22: 5) can be dated to the LBA thanks to similar forms found in the lower city of Boğazköy²²⁵. *Pithoi* of Hittite date generally have simple rims out thickened or differently modelled compared to types found in our survey. Types 8A.1 and 8A.2 (Fig. 22: 465 and 471) have been found in Boğazköy²²⁶. Only vaguely similar to our nos 483, 488 (Fig. 24), 480 (Fig. 23) are some specimens found in Kuşaklı²²⁷. In the same levels the flattened and pointed rims found generic parallels²²⁸ but squared rims like our type 8B.1 (Fig. 23) are rare, apart from a few sporadic cases. In Kuşaklı the storage containers usually have round outwardly thickened rims²²⁹; and large basins/tubs²³⁰ can provide adequate parallels for our specimen no. 481. Other examples of large containers dating to the Imperial period and useful as general reference are found at Kuşaklı²³¹. Apart from no. 465 (Fig. 22²³²) it seems that our specimens in plain ware are probably of later date, although we cannot determine their chronology with greater precision. In some cases, the use of both red slip and white/buff slip on the rim or below it, sometimes also reserved, (Fig. 24: 484, 485; Pl. 17: 7) offers comparisons with specimens documented at Kuşaklı and Boğazköy²³³.

Only generic remarks can be made about the bases of open and closed forms collected during the survey (Fig. 31), since there are very few specialised shapes that were used for many centuries. Kuşaklı and Boğazköy offer possible parallels of LBA date for some of our round types nos 566-567, probably of closed shapes²³⁴; no. 569²³⁵; for ring bases of open shapes nos 577-578²³⁶ and no. 572²³⁷ and pointed bases like no. 569, but larger in size²³⁸. Also the expanded thick flat base no. 565 and the conical pedestal base no. 581 – the Uşaklı specimen is in orange fine ware or Red Lustrous Wheelmade Ware – have some parallels in the same levels²³⁹. Round bases, ring bases and pointed bases are typical of Hittite period layers but this do not preclude the shape from continuing also in the IA and later periods. The string-cut marks evident on the external side of some small bases (Pl. 22, 3) probably from conical

²¹⁹ Orthmann 1963: taf. 17: 46, level 9=*karum* IV-III, transitional period; taf. 35: 361, level 8a, recent *karum* period; Fischer 1963: taf. 22: 229, Hittite period.

²²⁰ Fischer 1963: taf. 59: 543-544; taf. 60: 550; Matsumura 2005: taf. 29: KL96-M109, KL94-M69, for no. 502; taf. 28-29; Mielke 2006: taf. 34: 17; Parzinger, Sanz 1992: taf. 1: 19.

²²¹ Fischer 1963: taf. 59: 542.

²²² Mielke 2006: taf. 34: 16, with elusive rim; Müller-Karpe 1988: taf. 23: T12b.1, T12a.1.

²²³ Mielke 2006: taf. 34: 18; taf. 35.

²²⁴ Mielke 2006: taf. 40: 17.

²²⁵ Fischer 1963: taf. 81: 651; Parzinger, Sanz 1992: taf. 17: 11 for the button-like application.

²²⁶ Parzinger, Sanz 1992: taf. 3: 2, 4; taf. 1: 6.

²²⁷ Mielke 2006: taf. 47:4, 3; taf. 44: 4.

²²⁸ Mielke 2006: taf. 45: 5.

²²⁹ Mielke 2006: taf. 44-47.

²³⁰ Mielke 2006: taf. 75: 1-12.

²³¹ Mielke 2006: 85-87.

²³² Reminding Fisher 1963: taf. 72: 670.

²³³ Mielke 2006: 142; Müller-Karpe 1988: 146: taf. 48.

²³⁴ Mielke 2006: taf. 76: 8-10; Parzinger, Sanz 1992: 32: type Q 1.2.

²³⁵ Müller-Karpe 1988: taf. 44: type B1.

²³⁶ Mielke 2006: taf. 77: 19-25.

²³⁷ Mielke 2006: taf. 77: 30-32.

²³⁸ Mielke 2006: taf. 77: 30-32; Parzinger, Sanz 1992: 32 type Q 1.1 a-b.

²³⁹ Parzinger, Sanz 1992: 32: type Q 2.4 a; taf. 20: 6; Müller-Karpe 1988: taf. 46: type B26. For the Red Lustrous Wheelmade Ware see references at pag. 69, this article.

beakers, are also documented in Büyükkale²⁴⁰ and this characteristic trace of the manufacturing process dates from the mid- 18th century BC to the 13th century BC. Among the profiles dating to the pre-Hittite period are specimens similar to our no. 579 (Fischer 1963: 7: 98).

Beak spouted jars, defined as *schnabelkannen* by German scholars, fall within the morphology of those found in Boğazköy²⁴¹. Similar but not close parallels have been found for the miniaturist variant (Fig. 29: 551), but this is a small version of types documented in Boğazköy levels dating to the Hittite period²⁴². The kind of beak spout with tip curved downwards (Fig. 29: 541) occurs from the *karum* period onwards and short beaks are attested²⁴³, although this type continues to be produced during the Iron Age too.

Some fragments are problematic in terms of typological definition, given the poor state of preservation or particularly odd shape. In the most cases the small portions of sherds have been counted and classified as pieces without understandable morphology. Of those sufficiently well preserved and reproduced in Figure 30, we have only been able to suggest a plausible interpretation in very few cases, such as no. 561 which could be part of a draining device like those found in Kuşaklı²⁴⁴.

Among the handles some specimens can be dated to the LBA period. Type H1 (Fig. 32: 583-584; Pl. 16: 5), a kind of humpback handle sometimes with sharp edge, finds good parallel at Kuşaklı²⁴⁵. Here and at Boğazköy specific forms attested within our repertoire have also been documented²⁴⁶.

A few fragments of closed shapes, mainly body sherds, with linear incisions and geometric stamps have been found. Incised potmarks are characteristic of the LBA period as clearly documented in different sites²⁴⁷. One of our specimens (Fig. 34: 635; Pl. 20: 3) falls within this typology of marks. The stamped marks on the vessel body, often on the shoulders of closed shapes (Fig. 34: 627-634) recur from the *karum* period to the Old Hittite period²⁴⁸ and are documented in several sites. Impressions of the so-called 'royal sign' (nos 633-634) and pattern with concentric circles are attested at Boğazköy and Alaça²⁴⁹. Furthermore, a specimen of handle with an impressed mark has been found (Fig. 33: 604), probably a winged animal. Five of these sherds with stamp impressions were recovered on the eastern slope of the terrace. At Alişar stamp seals in clay with the 'royal sign', concentric designs and volatiles representations were documented²⁵⁰.

Incised, stamped and excised patterns used as decoration (Fig. 34, 637; Pl. 21: 4) are usually part of the EBA horizon but are documented also in the *karum* and Hittite periods (Fischer 1963, 75). The specimens with series of cut triangles could fall within this kind of decoration (Fischer 1963, taf. 127: 1181-1193).

The handmade plate or terrine like our n. 642 (Fig. 35) remains of uncertain date but it is worth mentioning that similar shapes are documented in the earlier periods (Late Chalcolithic and EBA) but also in the LBA and IA levels as documented for example at Kaman-Kalehöyük and Kuşaklı²⁵¹.

2.2.5.₃ The Iron Age occupation

It is difficult to draw a clear distinction between repertoires dating to end of LBA and the beginning of IA on the basis of morphology and fabrics alone. As noted above, the first impression is of a general continuity in the use of same sources of clay and a similar quality of inclusions and finishing techniques at the turn of the millennium as well as partially during the first centuries following, as documented for example at Kaman-Kalehöyük and Boğazköy (Genz 2007: 132; 2003: 180-181). At the same time, there are no clear typological markers which would enable us to distinguish between the repertoires of the middle and the late IA.

²⁴⁰ Fischer 1963: taf. 12: 101; taf. 6: 71; taf. 7: 98.

²⁴¹ Fischer 1963: taf. 21-34.

²⁴² Fischer 1963: taf. 33: 319-322, in particular 322; for our no. 541 cfr. taf. 27: 285-286.

²⁴³ Fischer 1963: taf. 35, 37.

²⁴⁴ Hüser 2007: taf. 39-46.

²⁴⁵ Mielke 2006: 149 type He6.

²⁴⁶ For Pl. 16: 6, K08.1560 cfr. Mielke 2006: 149: type He8; Fischer 1963: taf. 468; taf 46: 474 *lisenflaschen*; taf. 47 and Müller-Karpe 1988: taf. 1: 2.

²⁴⁷ Mielke 2006: taf. 82-84; Gates 2001.

²⁴⁸ Seidl 1972: A50-52.

²⁴⁹ Seidl 1972: A33, 36 and A26; Boehmer, Güterbock 1987: pl. XLII, 328; Arik 1937: XIII: Al. 18; Koşay, Akok 1966: lev. 22: Al.g.148, Al.e.72; 1951, Lev XLIX: res. 1; lev. 23: Al.f. 189, 187.

²⁵⁰ Schmidt 1932: 147: Fig. 184; Von der Osten 1937b: Fig. 258, bottom; Fig. 257; Fig. 249, upper line.

²⁵¹ Matsumura 2005: taf. 34; taf. 105; Mielke 2006: 126-127: type Te 2.

One of the clearest indicators enabling us to assign a specimen to the 1st millennium horizon is the presence of painted geometric decoration on light slip or directly on the surface (Wheelmade Painted Wares; Pls. 23-25), often in the so-called pottery style Alişar IV or V, characteristic of the fourth and fifth levels at the site of Alişar Höyük. Also for the IA the long sequence exposed at Alişar during the first decades of the twentieth century represents a point of reference for the main chronological partitions and provides us with a series of types and wares for comparisons. As observed at the time of excavations (Schmidt 1933: 40-53), it is not possible to subdivide level V into distinct phases and we are not yet able to distinguish clearly between common ware sherds of different two periods. This statement still hold true in many respects today. The painted decoration pattern is the feature that distinguishes Alişar IV from Alişar V (dating roughly from the collapse of Hittite kingdom to Alexander the Great). Three further sites provide us with reference repertoires for the IA. The site of Kaman-Kalehöyük, though far from our region, lying about 100km south-east of Ankara, represents a key site for the development of the pottery production across the transition between the 2nd and 1st millennium BC, thank to the stratified contexts there exposed. The Phrygian levels of Boğazköy dating from the 8th to the first quarter of the 6th century BC (Bossert 2000: 168) represent the reference point for our types, with a varied repertoire of plain and painted wares. Furthermore, the late IA settlement exposed on the acropolis of Kuşaklı and dated to 7th-early 6th century BC (levels 6 and 7, village and fortress), shows an articulated repertoire of plain wares and the presence of few painted sherds, probably because of its marginal position in relation to the area in which this painted tradition was widespread.

The majority of types belonging to bowls with curved profile, pointed or simple rims, continue to be produced between the LBA and the IA period and find comparisons in sites like Kuşaklı, Boğazköy and Kaman-Kalehöyük. In the earliest phase of the EIA a continuity of the Hittite tradition in making wheelmade pottery has been documented (Genz 2004: 48), as already noted above. The so-called drab ware production characteristic of the late Empire in some way developed and continued after the Empire itself collapsed, and types like simple bowls overlapping the two periods may not be dependable chronological markers for distinguishing between the LBA and start of the IA, for example. Quite how new the IA occupation at the site may have been is still unclear but, as we have already said, no hand-made Early Iron Age materials similar to the Boğazköy assemblage (Genz 2004: 24-28 and 2003) has yet been identified at Uşaklı.

Bowls of reduced dimension with simple pointed rims (Fig. 3: 38, 39, 50, 53-68 and Fig. 4: 69-74) have parallels in Kuşaklı IA levels²⁵², as well as specimens with a pointed rim that just barely curves inward (Fig. 3: 59-64)²⁵³. Types like nos 42 and 50 are documented at Boğazköy²⁵⁴. Conical bowls could be dated to different periods. Even though similar types have been found in LBA contexts, types like nos 114-115 (Fig. 6) are also documented in the IA period of Kuşaklı²⁵⁵. Bowls with ridged and outer thickened rim no. 138 (Fig. 6) and no. 201 (Fig. 9) are similar to examples from to Boğazköy²⁵⁶. The particular pointed inner side of the rim as attested in our nos. 151, 153-158 (Fig. 7) and the lightly carinated profile of the bowls remind types of Kuşaklı IA levels²⁵⁷; and also the medium sized curved bowl no. 202 (Fig. 9) finds here some parallels²⁵⁸.

Curved bowls with projecting tapered rim similar to no. 213, type 2A.29b (Fig. 10), are attested in the Middle Iron Age level of Kaman-Kalehöyük but the type begins to appear from the end of LBA²⁵⁹. The same site offer provides good confrontation dating to the beginning of the 1st millennium BC for different types of open forms, in particular for conical bowls like no. 93 (Fig. 15)²⁶⁰; some variants of type 2A.19c (Fig. 8: 164-165)²⁶¹; curved bowls type 2A.26 (Fig. 9: 203)²⁶²; and in part for type 2A.23a (Fig. 9: 195-196)²⁶³. The triangular rim (Fig. 9: 206) has general parallels with specimens from Middle Iron Age

²⁵² Powroznik 2010: taf. 24: 10-20; taf. 26: 13-16, 29-30.

²⁵³ Powroznik 2010: taf. 24: 22-26, 33

²⁵⁴ Bossert 2000: taf. 70: 792, 790.

²⁵⁵ Powroznik 2010: taf. 26: 54-55.

²⁵⁶ Bossert 2000: taf. 71: 818; taf. 69: 779, even if smaller.

²⁵⁷ Powroznik 2010: taf. 15: 5-6; taf. 14: 12-18; taf. 12: 20.

²⁵⁸ Powroznik 2010: taf. 16, 9-10.

²⁵⁹ Matsumura 2005: taf. 108: KL89-M198; taf. 36: KL89-M51; in part taf. 50: KL98-M96.

²⁶⁰ Matsumura 2005: taf. 76: KL92-M80.

²⁶¹ Matsumura 2005: taf. 76: KL92-M80.

²⁶² Matsumura 2005: taf. 69: KL90-M99.

²⁶³ Matsumura 2005: taf. 79: KL87-M363.

contexts²⁶⁴. In the light of the Kaman-Kalehöyük repertoire, we can attempt to identify useful chronological pointers for some morphological elements of curved bowls, in particular the outer and inner thickened rims that become popular in the Middle and Late IA, from chronological unit IIa6-IIc1²⁶⁵. Curved bowls with simple rim (Fig. 12: 274, 279-281) find more precise parallels in Kuşaklı levels 6 and 7²⁶⁶.

S-profiled bowls type 2A.30 (Fig. 10: 217-219 and 221) with painted decorations can be dated to the Middle Iron Age: these are, in effect, documented in the Phrygian levels of Boğazköy²⁶⁷ and in Kaman-Kalehöyük²⁶⁸. Among the carinated bowls type 2B.15b, a vague parallel can be drawn for one example (Fig. 13: 321) can be made with a specimen from Kuşaklı²⁶⁹.

Small jars with painted decoration belong fully to the IA horizon. The specimen no. 361 (Fig. 16) finds parallels in Kaman-Kalehöyük²⁷⁰; here the type is documented from the end of LBA to the Achaemenid period.

Short necked jars 6A.2 and 6B.1 (Fig. 19: 401, 407-410) are very generic types from a morphological point of view and can be dated to different periods. As for types of possibly IA date parallels are mainly from Kuşaklı²⁷¹ but some specimens have been found also in Boğazköy²⁷². In general these kinds of jars are well attested during the IA period²⁷³. Moreover the recurrent presence of outer thickened rims, slightly pointed could be an element that supports our suggestion, because, generally, specimens with round rims are more frequent in the LBA contexts. The state of preservation of necked jar nos 430-443 (Fig. 20), individuating types 6C.2-4b, is poor and prevent us from finding appropriate parallels. In any case this shape is too generic for it to be assigned to any specific chronological range. In Kaman-Kalehöyük similar types have been found in contexts dating to the first part of the IA²⁷⁴. The presence of painted decoration (as nos. 441-443) increase the chances of positively attribute a sherd to the IA horizon.

As far as large storage jars are concerned, types 8A.1-3 (Fig. 22, in particular nos 465, 470, 471, 473) recall IA specimens dating from approximately 8th to 6th cent. BC²⁷⁵. Something similar to our no. 483 (Fig. 24) is found in contemporary levels at Kuşaklı²⁷⁶. A peculiarity of the manufacturing techniques connected to the shaping of large storage jar is the rope impression on the rim (Fig. 21: 464) which has been documented in a specimen from Kaman-Kalehöyük²⁷⁷.

Several fragments homogeneously spread over the surface of the high mound and terrace are from funnel-shaped and large sized jars, also called craters, and could well belong to this horizon. Also the type with inner lid ledge, apparently well defined in shape and easily recognisable even from a small rim fragment, appears during the 2nd millennium BC, as above noted, and persist down the Hellenistic-Roman period (300-100 BC), making it even more difficult to date solely on the basis of rim morphology, surface treatment and fabrics. Our sherds belonging to types ZA, in particular those with lid support ledge are ascribable to funnel shaped jars and craters, but the poor state of preservation of the specimens which are limited to rims and small portion of the neck, prevent us from determining the precise category of closed forms to which they could belong. Apart from some profiles dating to the previous period (see above paragraph on 2nd millennium BC), these profiles are well documented in Kaman-Kalehöyük particularly in Middle and Late IA contexts (Matsumura 2005: taf. 132-139; 177-182). Even though these types continue to be produced, but in common ware, until the Achaemenid period²⁷⁸, and sporadically, even later, the occurrence of painted ornamentation is a good indicator relating to the Middle IA tradition, the painted specimens finding convincing parallels in the Phrygian painted repertoire of Boğazköy.

As regards the painted patterns, no animal silhouettes characteristic of the Alişar IV style were found during the survey, whereas concentric circles and other geometric patterns are documented (Pls

²⁶⁴ Matsumura 2005: taf. 202: KL87-3127.

²⁶⁵ See in general Matsumura 2005: taf. 154.

²⁶⁶ Powroznik 2010: taf. 27: 1-10 and cfr. Powroznik 2010: taf. 22: 16-19.

²⁶⁷ Bossert 2000: taf. 75-81.

²⁶⁸ Matsumura 2005: taf. 75: KL90-P type; taf. 116-118.

²⁶⁹ Powroznik 2010: taf. 27: 12.

²⁷⁰ Matsumura 2005: taf. 46: KL89-P22.

²⁷¹ Powroznik 2010: taf. 43, 24-30; taf. 46: 6.

²⁷² For example Fisher 1963: taf. 61: 564.

²⁷³ Powroznik 2010: taf. 155-156.

²⁷⁴ Matsumura 2005: taf. 100-101.

²⁷⁵ Bossert 2000: taf. 97: 1123; and taf. 99: 1132-33; Powroznik 2010: taf. 29: 2; taf. 31: 3-7; and taf. 33: 21-23.

²⁷⁶ Powroznik 2010: taf. 29: 6-8.

²⁷⁷ Matsumura 2005: taf. 126.

²⁷⁸ Matsumura 2005: taf. 215-218.

23 and 24). The band of fully painted triangles on the body of a wheelmade sherd where also a particular type of composite triangles motif is attested (Fig. 34: 617; Pl. 25: 3, K08.2199), apparently not so common in the middle IA, bears a vague similarity with motifs of the EIA horizon as far as the composition is concerned²⁷⁹, though for the profile could be of middle IA tradition²⁸⁰. The 'fir sprig' motif (Fig. 34: 615) is also unusual and could be part of the representation of a tree, as is the possible hat/helmet with appendix (Fig. 34: 621) that has not fitting parallels amongst the typical iconographic attributes of human figures in the repertoire of the Phrygian period²⁸¹.

Grey ware sherds are only sparsely documented on the surface of the mound and it is difficult to propose a date for the few specimens we found (Pl. 21: 3-6). In one case (Fig. 28: 530), the shape of the rim has a persuasive parallel in one of the distinctive types of ledge-rimmed jars in Phrygian Grey ware, widespread in the area of Kırşehir, Nevşehir and Niğde²⁸² and dating probably to 8th-7th century BC.

Some types of handles can be dated to the Middle and Late IA. Handles with finger impression H2 (Fig. 32: 585) and those with rectangular section H3 (Fig. 32: 586-587) find parallels in the repertoire of Kaman-Kalehöyük²⁸³ dating approximately to 500-300 BC but are also reminiscent of similar types in Kuşaklı Middle IA levels²⁸⁴. Handles with longitudinal groove H6²⁸⁵ are also documented and we have related these to later repertoire, on the basis of fabrics which show greater similarity with the specimens preliminarily dated to the Hellenistic period onwards (Pl. 13; Pl. 18). Also handle type H14 (Fig. 33: 608) occurs in the repertoire of Alişar dating to the Iron Age²⁸⁶.

2.2.5.₄ The Later Periods: from the second half of 1st millennium BC to the modern occupation

A quantity of specific wares scattered on the surface represent the material traces of a late occupation at the site that is to be dated to approximately the second half of 1st millennium BC onwards. At the moment we are not able to isolate many types noticeably diagnostic in plain ware for this period, and can make only a few remarks regarding this repertoire. At Alişar Höyük, Çadır Höyük and Kaman-Kalehöyük levels dating to the later periods, Hellenistic and Late Roman/Byzantine, have been documented (Schmidt 1931: 141-147; Gorny *et al.* 1995: 80; Matsumura 2005: 40; Cassis 2009) and remarks on these pottery repertoires, included in final and preliminary publications, can be very useful for our tentative dating of surface-find sherds.

2.2.5._{4.1} From the post-'Phrygian' to the Roman period

Among the open forms in plain ware types 2B.12a and 2B.12b (Fig. 13: 306-309) could be dated to the period between 500 and 300 BC. In fact similar cream slipped or grey bowls with expanded triangular rim (like our Fig. 13: 309) or variously thickened rims (nos 308 and 306) have been found in later contexts at Kaman-Kalehöyük, which dates up to the Byzantine period²⁸⁷. The specific triangular section of the rims like nos 206-207 (Fig. 9) recall the typology of some specimens in Grey ware from the chronological unit I of Kaman-Kalehöyük (for example Matsumura 2005, taf. 252: KL86-1056), dating approximately to 300-100 BC.

The fine production of the end of the 1st millennium BC, encompassing also the first centuries of the Common Era, is represented mainly by the polychrome band painted pottery (Pl. 24: 6; 5: K09.76, K09.36, K10.40) defined in archaeological literature as 'Galatian' (Maier 1963) and diffused within the bend of the Kızılırmak river, the area of Galatian settlement²⁸⁸. Due to lack of stratigraphic data, the precise period in which this ware was used cannot be determined, but it was probably in greatest use

²⁷⁹ Genz 2004: taf. 33: 8; taf. 34: 1, 6, 8; taf. 35: 2. Triangles of middle IA date are in Bossert 2000: taf. 15: 127; 104: 141; 140: 1274.

²⁸⁰ See for example the carination of the *dinos* in Bossert 2000: taf. 27: 253.

²⁸¹ Bossert 2000, farbtafel C and E.

²⁸² Summers 1994: Fig. 23: 3-7.

²⁸³ Matsumura 2005: taf. 207: KL86-182; taf. 211: KL86-50.

²⁸⁴ Powroznik 2010: 171.

²⁸⁵ Powroznik 2010: taf. 60: 14-16.

²⁸⁶ Schmidt 1933: Fig. 408: c 2692; and selection in Fig. 442.

²⁸⁷ Respectively Matsumura 2005: taf. 253: KL86-1203; taf. 254, KL86-1368; taf. 253, KL86-1026, for the rim.

²⁸⁸ Bittel 1974; Strobel, Gerber 2000: 256 and fig. 16a-b; Von der Osten 1937c: 21-22, 36; Fig. 30: 3369; Fig. 31; Schmidt 1933: plate II; Özsait, Özsait 2003. See also Strobel 2009 about the Galatian settlement in the Central Anatolian Plateau and 1997: 141-142 for the possible identification of Uşaklı with the city of Podanala.

between second to first century BC and the 1st century AD (Maier 1963: 236). Although Galatian pottery roughly indicates the Hellenistic period and the rise of Roman Empire under Augustus, we cannot yet exclude an earlier origin with its roots in the local IA painted tradition from which geometric patterns and shapes are derived. Several painted sherds, in particular with linear and geometric decoration, sometimes polychrome (Pl. 24: 1-4, 7) belong mainly to the horizon of Alişar V, the exact composition and chronological limits of which have not been clearly established. Reddish surfaces with painted bands are characteristics shared by other productions dating to the IA, mostly of late date (Pl. 24: 5; Pl. 25: 1-3). Generally we have classified as Galatian only the thin sherds belonging to fine open shapes and small bowls with well smoothed surface and decorated with horizontal parallel stripes and concentric lines in red, brown and white/greyish colour, or on a white band (Pl. 24: 6 and 5, the sherd at the centre; ware Pt, group 6). Obviously in this way Galatian sherds are underrepresented and their identification relates mainly to the coexistence of fine fabric and the presence of the white painted line. We have considered more generally as late IA the sherds with common and coarser fabrics and rougher surface treatments as the sherds with painted geometric motifs on a white slip or background and of medium texture (Pl. 24: 1-4, and pieces with white slip in fig. 7). In both decoration and shapes, all of these styles show strong links with Middle Iron Age production.

Next to the Galatian style pottery, other fine wares, characterised by thick and brilliant reddish orange superficial slip (ware Os) as well as some of the shiny and well-smoothed slipped wares (whitish and pale yellow, red specimens belonging to ware Ys, Rs) might well belong to the same chronological range, from the late IA to the Hellenistic period (Pl. 26: 1-3, except Pl. 2, K08.1086 and K08.1606 that are Gold Wash ware specimens). This material can also be in part assigned to the Roman period (Schmidt 1933: 101). Usually the pieces show slip and burnished or polished surfaces. A limited number of red slipped diagnostic sherds have been collected whereas body sherds represent the majority. The red-brown surface treatment (Pl. 26: 7, K12.67 and K12.1562) could be indicative of to the same chronological range.

The profile and surface treatment of bowls type 2A.29a, in particular no. 212 (Fig. 10), attested also in the nearby site of Taşlık Höyük (see Fig. 37: 707 and Pl. 39: SS03 08.42, picture bottom left) are similar to a specimen found at Tilkigediği Tepe, north-east of Kerkenes Dağ, from a pit opened by robbers and dated to the pre-Hellenistic IA, probably to the period of the Achaemenid Empire²⁸⁹, s well specimen from Çadır Höyük dating to the LIA²⁹⁰. No. 212 and in part no. 214 are also dated at Kaman-Kalehöyük²⁹¹ to roughly between 500 and 300 BC.

As for the closed shapes, type 6A.5 (Fig. 19: 405 and 406; Pl. 27: 4) is characterised by ridges and grooves on the shoulder, an element recurring in some storage jars found at Boğazköy²⁹² and considered a post-Phrygian element, although documented in different periods (Bossert 2000: 133), and therefore of Hellenistic-Roman date. The date of type 6.3 (Fig. 19: 413-415) is problematic but within the range of the second half of 1st millennium or later. The general shape of no. 415 is close to a specimen from Kaman-Kalehöyük pertaining to chronological unit 2a3-5, roughly between 500 and 300 BC²⁹³. Also type 6B.4, in particular nos. 418-420 (Fig. 19) characterised by thin walls, a slight depression on the external part of the rim and light thickening of the inner portion, is documented in the same context of Kaman-Kalehöyük²⁹⁴. This similarity, however, concerns only the morphology since the example cited is registered as '04. *Blei farbige*', a classification close to the grey and polished wares (Matsumura 2005: 224-225).

Further elements in the later repertoire are the handles with finger impression H2 (Fig. 32: 585) and those with rectangular section H3 (Fig. 32: 586-587) that find parallels in the repertoire of Kaman-Kalehöyük²⁹⁵ dating approximately to 500-300 BC. Based on the characteristics of fabrics, colour and treatments also some body sherds and rims decorated by incisions could be dated to later periods (Pl. 27: 5-6, 8). The same applies to handle with punctuated decoration (Pl. 27: 7, K09.1185; see below the paragraph on the other identified sites for comparisons).

It is difficult to interpret some fragments with whitish/yellowish slip. No. 559 (Fig. 30) could be part of an animal-shaped portion of a vessel or figurine, similar to specimens found at Boğazköy²⁹⁶.

²⁸⁹ Summers *et al.* 1995: 46; Fig. 4.4.

²⁹⁰ Genz 2001: 170, Fig. 4.4.

²⁹¹ Matsumura 2005: taf. 198: KL87-3580 e 3049.

²⁹² Bossert 2000: taf. 97: 1120; taf. 132: 1136, 1137, 1141.

²⁹³ Matsumura 2005: taf. 211: KL86-1153.

²⁹⁴ Matsumura 2005: taf. 205: KL86-1294.

²⁹⁵ Matsumura 2005: taf. 207: KL86-182; taf. 211: KL86-50.

²⁹⁶ Fischer 1963: taf. 136, lower portion of the plate.

We have not direct parallels for the fragmentary theriomorphic head no. 558 which could be part of an animal-shaped pot or an element applied to a large vessel²⁹⁷. The suggestion that this could be part of a figurine cannot be excluded since similar cases are documented for this period.²⁹⁸

The unusual rim no. 475 (Fig. 23) belonging to a very specialised kind of *pithos*, could date to the very late 1st millennium, given that a somewhat similar rim is found at Kaman-Kalehöyük²⁹⁹ dating between 300 and 100 BC.

During the 1928 survey season, H.H. Von der Osten first documented the presence of levels dating to the Later Periods at the site. It is certain that the pot containing 28 Hellenistic silver coins, published as the Küçük Köhne hoard (1929: 37-38; 1933: 155-156, Fig. 109; Newel 1931), was found in Uşaklı Höyük. In fact the report shows a picture of Uşaklı taken from the east-south-east, erroneously captioned as 'Küçük Köhne', and given as the site where the hoard was discovered. Furthermore the reports describe the presence of remains of a gate built of large stone blocks (Von der Osten 1929: Fig. 32) and the site where these Hittite remains are visible above the ground is elsewhere indicated as Forrer's 'Kuschakly-Hüyük' near Küçük Köhne (Von der Osten 1930: 171). This overlapping of places and names has already been noted (Summers *et al.* 1995: 54) and was caused probably by the inadequate maps used at the time of Von der Osten's explorations in this area (see Mazzone, this volume, § 2). The fortification wall around the top of the high mound, built with large boulders could be late in date but this cannot yet be determined with any greater accuracy.³⁰⁰ The very scant presence of sherds dating to Late Roman/Byzantine periods found on the surveyed portion of the slope and on the superficial layer of the top of the mound, in the Operation 1, could however represent clues against a very late date for the circuit wall.

2.2.5._{4.2} *From the Roman-Byzantine period to the Modern Era*

At present we are unable to determine the duration of Byzantine use of the site on the basis of the limited surface pottery repertoire alone, or of when the site was first occupied or finally abandoned. The rural life and settlement pattern during the Byzantine period is not documented fully enough for this area. Some useful indications for dating occupation come from Çadır Höyük where evidence of continuous use of the site from the early Byzantine to the middle Byzantine period has been found (roughly from the 5th century AD to 11th century AD). The relative proximity of the two sites, the similar location within markedly agricultural areas (similar functions?) and some general affinities in the ceramic assemblage could suggest that a comparable settlement and period of use could be attested at Uşaklı.

Particular fabrics, surface appearance and colours are some of the distinctive elements characterising the ceramic production that we assign to the late Roman/Byzantine period (Coarse Grained Ware, pseudo-Brittle Ware).

As for as the plain production is concerned, our pseudo-Brittle ware (name deduced from Northern Mesopotamia contexts³⁰¹) can be mentioned as typical and easily recognisable during the survey. Orange-red to brown and grey colours, no slipped surfaces and traces of summary smoothing are characteristics of this production. The fabrics are granular with sand inclusions, mineral particles of different colours and limestone. On the surface blackened patches are frequent, resulting from daily use for cooking activities or lack of control during firing in the potters kiln. Wheel marks are also frequently attested. It is hard to find comparisons for this repertoire in sites of the North Central Plateau and in some cases we can obtain general support for a chronological classification and a useful reference framework only by looking at a wider geographical area. In fact single components and features of the vessels are shared with assemblages brought to light in sites stretching from the North Western Anatolian regions to the Euphrates and Cilicia.

Ribbed rim bowls (type 2B.6, fig. 12: 285-288) have parallels with specimens found in level III of Porsuk dating to the IA³⁰² but the surface finishing and texture betray general similarities with materi-

²⁹⁷ Von der Osten 1937c: Figs. 80, 55-56: 1356; Bossert 2000: 138.

²⁹⁸ Von der Osten 1937c: Fig. 89.

²⁹⁹ Matsumura 2005: taf. 233: KL87-3476.

³⁰⁰ The trend to build on mounded sites is documented in the area. The Tilkigediği Tepe tower and Göz Baba tumulus, respectively north-east and south-west of Kerkenes Dağ, Keykavus Kale within Kerkenes and probably Sumerin Sivri Hisar, west of Alişar Höyük show traces of stone ramparts (Summers *et al.* 1995: 52-53). A prototype is the Phrygian period glacis in Boğazköy (Bittel 1970: 147-148).

³⁰¹ See footnote below no 4 for a brief description of Brittle ware.

³⁰² Dupré 1983: Fig. 76, 108-109, yellow slipped.

als that we consider more characteristic of the later periods. The handle with two longitudinal grooves no. 594 (Fig. 32), well attested in our collection, and the specimens with single groove no. 595-97 (Fig. 32) have parallels in types from Elaiussa Sebaste³⁰³ dating between 5th and 7th century AD; and in the repertoire for example of the distant Saraçhane, in Istanbul. Also the type of rim on thin shoulder no. 416 (Fig. 19) vaguely remembers cooking pots dating to the 10th-12th century AD³⁰⁴. Squat handles with longitudinal finger impressions are usual in Late Roman amphorae, one of the more widespread types in the eastern Mediterranean between 5th and 7th centuries AD and beyond³⁰⁵, even though our specimens are flattener. The fragment of a red slip deep cup n. 222 (Fig. 10) with everted rim with end that forms an angle (about 45°) and curves nearly vertical, brings to mind a type attested in the distant Sagalassos³⁰⁶. Red-slip wares, in fact, began to be produced during the Augustan period and lasted until the mid-7th century AD (Poblome 1999: 25) and this represents a serious obstacle to assign a limited date to our specimens in the absence of a clear sequence for the area and on the basis only of small fragments. Further investigations and excavations are required to understand the quality and nature of the settlement during this period. The pottery would appear to be a regional production destined to a local market, with few specialised elements, and not mass-produced Roman wares.

Glazed ware sherds are very rare on the mound. In general the glazed ceramics have been produced from the Byzantine period until the Modern Era and, given the context of the finds, i.e. the surface slopes, here only a vague chronological date is attempted whilst a better classification of the production will be left to the specialists. The base in white paste and blue decoration (Fig. 31: 576; Pl. 33: K09.960) can be generally dated to the Ottoman period, from the 15th century AD onwards (Özkül 2003: 107-108). This blue and white sherd could be similar to the group defined as 'Baba Nakkash' style, spiral serrated leaf style ('Golden Horn' ware), but it is only a preliminary suggestion. A further 4 sherds (Lot 9, bands 1 and 2; survey unit J19) show a monochrome green glazed surface and a red-grey clay core (Pl. 33: K12.30; and one fragment (survey unit L5 show a reddish-brown glaze). The green glazed wares date from the Byzantine period and continued to be produced for several centuries thereafter. A typical green glaze pottery production is that from Iznik in the Ottoman period, composed of quartz-frit, compact and hard, which began in the 14th century AD and is documented until the 17th century AD.

2.3 Small objects and other finds

A very limited number of complete and fragmentary objects were found during the surveying activities and most parts of these come from the scraping on the slopes, only a few have being found on top of the lower terrace.

Apart from the significant finds of six fragmentary tablets with cuneiform characters³⁰⁷ and a clay bulla subjects of separate contributions (see below A. Archi *et al.* and M. Poetto), the collection of objects consists of everyday tools which, in terms of their function, are probably to be related to both domestic and craft production contexts.

Three fragmentary baked clay spindlewhorls (Pl. 37: 7-9) came from the surface of the eastern slope. They present an asymmetric biconoid profile and are small in size³⁰⁸. Colours vary from light brown to pinkish and reddish on the surface and grey in section. Similar objects have been found for instance at Alişar, in the level dating to the 1st millennium BC, approximately from the Phrygian to Achaemenid period³⁰⁹. Here it has been noted that the conoid or biconoid shape is particularly characteristic of the level V³¹⁰.

A small spheroid item with a flattened base (Pl. 37: 5) is preserved in full³¹¹ and is made of a blackish stone which may be hematite. A round object partially similar to our specimen is in Boğazköy³¹²

³⁰³ Ferrazzoli, Ricci 2007: Fig. 11 and 36; Fig. 4: in particular 15, 18, 20, 63-65.

³⁰⁴ Haynes 1992: Fig. 63: 4-5.

³⁰⁵ Similar types have been found on the nord shore of the Black Sea for example (Sazanov 2007).

³⁰⁶ Poblome 1999: Fig. 17: 5.

³⁰⁷ Five fragments come from the surface, one from the superficial layer of Area C, close to a fox nest. Fore measures see the articles by Archi *et al.* and Poetto, this volume.

³⁰⁸ No. 7, UK12.E.7 (Lot 12, band 3): h. 3.1cm; dia. max 3.8cm; dia. central hole 1.1cm; weight 35gr; no. 8, UK12.E.9, (Lot 12, band 5): h. 2.5cm; dia. max 3.5cm, dia. central hole 0.7cm; weight 16gr; no 9, UK12.E.16 (Lot 9, band 4): h. 3.2cm; width 3.5 cm ca.; dia. hole 0.6cm; weight 15gr.

³⁰⁹ Schmidt 1931: 137, Fig. 193; Von der Osten 1937b: Fig. 506: e2006, 2001.

³¹⁰ Schmidt 1932: 258.

³¹¹ No. 5, UK09.Es.4 (G 16, c 2): h. 1.7cm; dia. 2; weight 12gr.

³¹² Boehmer 1972: taf. XCVII: 2396A.

where has been interpreted as pawn. Its possible identification as a small weight, maybe a shekel of Khatti, cannot be excluded at the moment³¹³.

The conical stone whorl decorated with parallel horizontal lines (Pl. 37: 1) comes from the southern slope³¹⁴. The object is complete and the colour of the stone is between brown and dark grey. Similar whorls have been found in Boğazköy³¹⁵, most from layers dating probably to the post-Hittite period, but of not more certain date. Different strata exposed at Alişar, dating from post-Empire to the Byzantine period, have yielded similar objects³¹⁶.

The biconic spindlewhorl with groups of incised radial lines (Pl. 37: 4) is probably in serpentine stone, with greenish and blackish nuances³¹⁷. Parallels may be found from level I of Boğazköy lower city³¹⁸ and Alişar Höyük³¹⁹.

From the southern slope, Lot 9, respectively band 6 and band 8, come a ball sling in light brownish grey calcareous stone, wholly preserved (Pl. 37: 2)³²⁰, attested also at Boğazköy³²¹; and a dome shaped object in pale brown stone with flat base showing traces of cutting, possibly an unfinished seal (Pl. 37: 3)³²².

In Operation 1, on the northern portion of the top of the high mound, a bead in blue glass material was found (Pl. 37: 6)³²³.

Chipped stones, mainly flakes of flint but also obsidian were spread over the lower terrace and on the southern and eastern slopes of the high mound³²⁴. The collection consists of types similar to points and scrapers but are mainly waste flakes. Some pieces are in dark red stone (Pl. 37: 10-11), others in red (Pl. 37: 12-13) or whitish stones (Pl. 37: 15-16); a couple of lithic instruments are in obsidian (Pl. 37: 14) and present a triangular cross-section. Retouching is marginal, often visible on both sides; as well as dorsal negatives and in some cases bulb and cortex. A few other small pieces of debitage and chipping debris have also been found.

Apart from the specimens reproduced in the plates, the further following small waste flakes in different stones have been collected. The fragments are in obsidian (fragm. 1, Lot 2, band 3), amber-coloured stone (fragm. 2 and 3, Lot 2, band 3), greenish stone with red cortex (fragm. 4, Lot 4, band 2) and red flint (fragm. 5, from Lot 3, band 4; fragm. 6, Lot 4, band 2). Fragments of a mace head (UK8.Es.3, Lot 3, band 3) and other worked stones have also been found (UK08.Es.1, Lot 2, band 4 and UK09.Es.6, G 19, b 2).

From the eastern slope come two fragments of heavy, pierced stone tools, probably hammers (Pl. 38: 1, 4)³²⁵. The stone is hard, heavy, dark grey in colour, probably gabbro or granite/andesite. They are characterised by rough surfaces and the inner surface of the central axial hole is polished in the case of the ovoid specimen with flat side no. 1 and polished with traces of drilling in case of the spherical specimen no. 4 (here there are also traces of a second polished hole, probable orthogonal to the first). A parallel for this last specimen can be found at Kuşaklı³²⁶. We do not know whether these pieces were left unfinished or broken at a later time but the surface apparently shows none the typical traces of use found on hammers or pounders. Similar tools come from Boğazköy³²⁷.

Two other pierced pale brown/ grey calcareous stones have been found (Pl. 38: 2-3)³²⁸, irregular in shape and with rough surfaces.

³¹³ Ascalone, Peyronel 2011: 99-100.

³¹⁴ No. 1, UK12.E.6 (Lot 11, band 3): h. 1.6cm; dia. max. 2cm; diam. min. 1.2cm; dia. hole 0.4cm; weight 7gr.

³¹⁵ Boehmer 1972: taf. XCIII: 2331; XCIV: 2350, 2351; 1979, taf. XXXVII: 3822, 3823.

³¹⁶ Schmidt 1931: 137, Fig. 192; 1933: Fig. 79; Von der Osten 1937a: 20; 1937b: Fig. 195.

³¹⁷ No. 4, UK9.Es.5 (Lot -1, band 2): h. 1.4cm; dia. 2.0cm; hole dia. 0.5cm; weight 8gr.

³¹⁸ Boehmer 1979: taf. XXXVI: 3810A.

³¹⁹ Schmidt 1932: Fig. 155: b1506, b1115.

³²⁰ No. 2, UK12.E.8 (Lot 9, band 8): max dia. 2.3cm; weight 16gr.

³²¹ Boehmer 1979: taf. XXXVIII: 3843, 3844

³²² No. 3, UK12.E.18 (Lot 9, band 6): h. 1.7cm; dia. 2.4cm; weight 8gr.

³²³ No. 7, UK12.E.13 (Operation 1): h. 0.18cm; dia. 1/0.8cm; central hole 0.3cm.

³²⁴ No. 10, UK12.E.21 (Lot 9, band 9): h. 4.4cm; len. 3.9cm; th. 1.2cm; No. 11, UK12.E.22 (Lot 12, band 4): h. 3.1cm; len. 2.3cm; th. 0.5cm; No. 15, UK12.E.20 (Lot 9, band 8): h. 2.5cm; len. 2.1cm; th. 0.45cm.

³²⁵ No. 1, UK12.E.19 (10m south of eastern slope limit): h. 4.7cm; th. 3.8cm; weight 261gr, greenish nuances; no. 4, UK12.E.15 (Lot 12, band 6): h. 6.7cm; l. 10.4cm;

³²⁶ Arnhold 2009: taf. 36: 5.

³²⁷ Boehmer 1972: taf. LXXXIX-XC; Schachner 2010: res. 2, 3a-c.

³²⁸ No. 2, UK12.E.14 (Operation 2, Lot 10, band 9; base of the southern slope): h. 3.2cm; w. 4.2cm; len. 6.6cm; dia. hole 0.9cm; no. 3, UK12.E.17 (lot 11, band 5 southern slope): h. 3.6cm; w. 5.1cm; len. 8.6cm; weight 183gr, th. max 6.8cm; weight 1184gr.

From the lower terrace, an unfinished mace head (Pl. 38: 6)³²⁹ of pale grey calcareous stone has a coarse surface, the central hole not passing through the stone entirely and showing traces of drilling.

Only one fragmentary grinding stone has been recovered on the surface of the eastern slope (Pl. 38: 5)³³⁰, and this has a flat face, convex side and is of porous stone.

The presence of tiles noticeably document some forms of occupation in later periods. Fragments of roof tiles (Fig. 36; Pl. 36) have been found mainly on the terrace and in different concentrations. Both flat tiles (*tegulae*) and half tube tiles (*imbrices*) share the same manufacturing process. *Tegulae* are rectangular/trapezoid with two raised borders along and around one side; squared profile flanges (cut across the top edges) and rounded profile flanges have been found. *Imbrices* are curved and U shaped. Finger grooves next to the flanges, wavy grooves and footmarks are usually visible on the upper surface of tiles, whereas imprints of chaff and reed ragged lines in the lower surface are remains of the base plate on which they were manufactured. The shape of the roof tiles is similar to that of specimens found, for example, at Amorium, in the Afyon region (Witte-Orr 2007: 295-308): here tiles both with cut flanges and others with rounded upper edged flanges document occupations at the sites probably between the 5th and 8th centuries AD, the Late Byzantine period. Finger groove, wavy line decorations and footprints are also documented on the upper surface of some tiles.

2.4 Scatters of sherds and other materials

Archaeological findings (ceramic sherds, slags, tiles) are spread regularly over most of the areas surveyed, sometimes following homogeneous patterns and at others, the scatters are uneven. In general the distribution of the samples is conditioned by modern ploughing activities, particularly on the terrace, and by slippage of soil on the slopes of the high mound. This state of affairs results, inevitably, in a mixed bulk of findings but, if we take into account a large enough representative area, some interesting information can be obtained and, in areas characterised by mixed materials, some original concentrations of finds can be recognised. Through counting, seriation and statistical analysis of the collected sample we are able to develop spreadsheets and produce graphic plots showing the scatter of different diagnostic markers, separating, at least in part, deposits from buried strata and mixed deposits caused by disturbance.

Analysing the occurrence of the various categories of artefacts over the site some remarks can be made regarding the contexts that possibly lay on or close to the surface³³¹. In particular, the flat surfaces of the terrace and its slight slopes provided samples consisting mainly of materials that came from layers directly beneath the surface. In the case of substantial archaeological remains (e.g. large buildings, large domestic quarters) directly below the surface and with a well-stratified sequence of horizontal layers, the sample is very coherent and without significant intrusions from other chronological horizons, despite having been disturbed by ploughing. In this case we can find various and good concentrations of materials in specific sectors of the site with a more diverse mixture of materials only in intermediate zones between sectors of different chronology or function. Instead, the sample from the steep slopes tend to be more mixed, due to slippage of the soil, as is that from the foot of the mound where agricultural activity had cut into layers of both the high mound itself and of the flat terrace (in theory, more recent). Here it is more difficult to identify any concentration of material that could be diagnostic for a certain period or indicate a particular function for the structures lying beneath the surface. The materials from recent contexts, when substantial, tend to cover any earlier ones and it is particularly difficult to distinguish a find from a layer directly below the surface from those that have been dragged in from neighbouring sectors where another occupation date may be preserved. Background noise is, therefore, obviously always present in the counts and percentages of different sampled areas due to the disturbance caused by ploughing and slippage along the steep slope of the high mound.

Bearing in mind the differences between individual cases and making a fine distinction sector by sector, albeit of varying reliability, the features of the collected sample may be of use in outlining the occupation sequence of a given area and identifying those areas where there is a greater probability of finding remains pertaining to different periods. In fact, sectors of major concentration emerge for many categories, reflecting in some cases random scattering, but often providing chronological and functional indicators.

³²⁹ No. 6, UK9.Es.7 (Lot 2, band 1b): h. 6cm; dia. 6.4cm.

³³⁰ No. 5, UK12.E.23 (Lot 12, band 6): h. 7.5cm; w. 12.4cm; len. 15.1cm; weight 1946 gr.

³³¹ For depositional processes and post-depositional problems see Taylor 2000: 16-26.

Figures 41-91 show the occurrence of the main types and wares³³². In many cases the scatter is homogeneous, and types well distributed between the top of the terrace, its slopes and the high mound³³³. The surface sherd density over the entire site is quite regular with a greater occurrence on the slopes and at the northern foot of the mound (Fig. 82). For this reason, the specific occurrence of a certain marker in a given sector of the site can provide us with real information rather than merely fortuitous evidence linked, for example, to a greater quantity of sherds in that area (and, consequently, a greater probability of more varied groups of finds). However it is necessary to make a specific distinction concerning the methods implied in the fieldwork. The use of different procedures in surveying activities on the slope of the high mound, such as surface collecting and scraping, furnished different quantities of finds. By scraping we obtained 5.2 ceramic items per m² whereas the surface survey on the slopes of the höyük yielded approximately 0.6 pottery finds per m². The ratio between scraping and surface survey is 8.67 to 1 pottery items per m². Comparing data from the same area that was subjected to both methods of collections, the results are considerably different in terms of the quantity of materials uncovered.

The distribution of wares follows a differentiated pattern showing various templates on the graphic plotting.

Wheelmade painted ware sherds were found mainly on the terrace and on the slope of the high mound (Fig. 69), with a few specimens on the slope of the terrace.

Orange slip ware is mostly documented on the top of the terrace, in the northern and north-western squares (Figs 71 and 78), whereas most of the pink slip specimens were found on the slope of the high mound (Fig. 71).

Wheelmade red slip sherds are regularly spread over the entire surface (Fig. 77), but the diagnostic finds were mainly concentrated in the north-eastern and eastern sectors of the terrace and on the slopes of the high mound (Fig. 72). This pattern follows, in part, that of the drab ware specimens (Fig. 67).

Yellow slip sherds are predominately on the terrace and high mound slopes (Figs. 73-74). The specimens more probably to be assigned to the Iron Age, on the basis of surface treatments, are concentrated on the mound and on top of the terrace, in the north-western sectors.

Kitchen ware tends to be better represented on the slopes of the mound, at its foot and, more sparsely, on the top of the terrace. The template of the scatters shows a blank spot in relation to the squares where Building II has been identified and a major occurrence the south-eastern slope (Figs. 80 and 87).

The frequency of wares and types to be assigned to late periods is greater on top of the terrace, particularly in western and north-western squares, and on the slope of the high mound (Figs. 78 and 82).

There is apparently no clear explanation for the ubiquitous occurrence of handmade sherds both on the mound and on the terrace (Fig. 81)³³⁴, apart from a possible movement of the soil in ancient times which could have dispersed these sherds over the entire site. The slope of the high mound returned a considerable number of such sherds, as did the eastern slope of the terrace and the northern foot of the mound.

Many ceramic types are not markers of a precise period as they were in use for long time. Often the distribution of diagnostic sherds is quite homogeneous and does not provide indications useful to identifying areas of particular concentrations (see for instance type 5 or type 6, Figs. 54-55). Type Z occurs at the foot of the mound and on the slopes of the terrace (Fig. 57).

Nevertheless, some sectors of the site show traces of heavier occupation in certain periods through the occurrence of some types whose date is more clearly definable. The 2nd millennium and LBA occupation, in particular, is best documented on the slope of the terrace that provided us with a good repertoire of drab ware specimens (Fig. 67), and fragments of beak spouted jars type 20A.1-2 (Fig. 63). Generally, the same slope, together with the slope of the high mound, provided us with other markers of the same period such as plates and low bowls type 1 (Fig. 43), body sherds with impressed stamps (Fig. 60), and further possible 2nd millennium types, like the few deep bowls curved (2C.1b) and with V shaped handle (2C.2) (Fig. 51).

Carinated bowls (2B.1-2b) or with incurved rim (2B.2c-5c and 2B.7a-7c), are diffused on the slopes and at the foot of the high mound (Fig. 49). The scatter of carinated bowls types 2B.8-18 (Fig. 50) follows a similar pattern. Carinated bowls type 2B.16-18, similar in surface aspect to the drab ware specimens, have a similar distribution (Fig. 50), with a major occurrence on the slope of the terrace. Small bowls

³³² Elaboration of the scattering maps using GIS is by Studio Kulla; for credits details see also footnote n. 1

³³³ In the western squares the sherds were in small fragments, sometimes crumbled, compared to the eastern sector where a high percentage of better-preserved sherds were found.

³³⁴ Five more handmade fragments of body sherds have been found during the survey, three of them on the mound and two on the terrace.

with pointed rim type 2A.2 have a good concentration on the slope of the terrace and high mound (Fig. 45). Again on the slope of the terrace the greatest concentration of large storage jar fragments was found (Figs. 56 and 86). Some of our storage ware seem to be located within the 2nd millennium ceramic horizon, and especially within the Hittite ceramic horizon. The dimension of our storage jars, as suggested by rim diameters and wall thickness of the preserved sherds, would have been quite conspicuous. If we consider the consistently smaller dimension of storage jars more frequently recovered in domestic contexts of the period (see Schoop 2011b), we can presume that our large pithoi are to be connected with contexts other than domestic.

Types of possible Iron Age date (2A.21-2A.31) are documented mainly on the slopes of the high mound (Fig. 48). Bowls with thickened rims or flaring rims are on the slope of the high mound and on top of the terrace (Fig. 48).

Types we considered to date to the late period are distributed mainly on top of the terrace and in part on the slope of the mound (Figs. 61-62). This is the case also for handles type H5 and H6 that occur mainly on the flat top of the terrace (Fig. 59).

Along with the data coming from ceramic sherds, also the scattering of other materials such as tiles and slags in noteworthy concentrations contribute to completing the framework of the occupation at the site. The greatest density of roof tiles has been registered on top of the flat terrace with some concentrations at the northern and western edges and in relation with the anomaly of the Building I (Fig. 90), in the north-eastern portion of the terrace. A definitely significant concentration is registered in the square F13. The occurrence of tiles on the slopes both of the mound and terrace is very low. Even though the presence of Roman or Byzantine structures cannot be excluded, the dispersed distribution pattern on the S-SE slope of the terrace might have resulted from erosion and ploughing.

A valuable concentration of melted residuals from combustion (mainly slags but also stones and a few ceramic wastes) are concentrated on top of the terrace in relation to the squares where Building II has been identified by geomagnetic anomalies (square K19-I19), on the north-eastern slope of the terrace (square G19); and on the slope of the höyük (Fig. 89). The distribution within the other sectors of the site seems to be mainly scattered. The presence of slags at the foot of the mound suggests the possibility of burnt levels and those found in relation to certain geomagnetic anomalies could reflect an interconnected phenomenon.

3. Other noteworthy identified sites: survey methods and findings

The small regional survey was aimed at identifying of sites and off-site scatters in the surroundings of Uşaklı and providing a basic sample of the archaeological landscape of the valley. The survey of the area around Uşaklı, for a radius of ca. 5km³³⁵, was extensive, with a low-resolution approach. We referred to previous research in the region and gathering information from local villagers as a preliminary guide to the location of sites of archaeological interest. However interviewing local residents about the presence of sparse ceramic sherds on their fields did not provide a positive outcome.

After a preliminary study of our topographic maps, satellite imagery and reports of previous works, systematic fieldwalking to seek sherds was conducted in the area that appeared most promising, i.e. along the courses of streams, near springs and rocks outcrops and choosing wide and flat representative areas to evaluate the possibility of sparse settlement. Fieldwalking was carried out also over ploughed fields and fallow lands, with cultivated fields limiting our activity to a certain degree. In some cases large fields devoted to cereal cultivation (mainly barley) were quickly explored after the harvest season but the crop residuals constantly hampered our ability to detect surface artefacts. Vans (local *dolmuş*) and a *Fiat Panda* car, particularly useful for the unpaved roads and off-road itineraries, were used to reach the targeted areas.

Once a site has been identified by the presence of archaeological materials the first field activity was collecting information on density of sherds and other materials, features of the archaeological deposit and taking note of evidence on the morphology of the area. Generally two types of archaeological sites were encountered: mounded sites and scatterings of materials, mostly sherds. A low level of archaeological artefact visibility was noted. Ten archaeological sites were recognised in the area assigned

³³⁵ The surveyed territory is shaped roughly like a quarter of a circle, the perimeter of which is marked by the villages of Babalı, Taşlık Köy, Incecayır and Dışlı. This area had already been partially surveyed in the context of the Alişar and Kerkenes archaeological projects.

for the surveying operations thanks to the presence of sherds dispersals (Pl. 13). Only two mounded sites were identified, site no. 3 and no. 9, which were further explored in a more detailed survey. Here the collecting was organised by dividing the surface into grids in line with the morphology of the soil. Leaving aside the two above-mentioned sites, no other concentrations merited further attention or intensive collecting given the very scarce presence of materials. In fact, handfuls of sherd scatters on the flat fields and hills was often the only element that enabled us to identify the other isolated contexts that may be considered off-sites areas of artefact distribution, which were probably short-lived and on virgin soil. These were materials exposed by ploughing or engineering works (routes, tracks, building sites) and their were located by walking along parallel transects over plots of the selected area. There is quite probably that some of these are not sites, in particular site 6, that could be earth containing few sherds deposited by a truck, and sites 8 and 13, respectively a sort of halo of Uşaklı lower slopes due to the ploughing of the nearby fields (or rubbish deposits?) and probably an off-site concentration. In addition to scatters among the agricultural fields, we registered ancient remains on top of a natural hill near Dişlı where some sherds, small cisterns, including one which is bell-shaped, could indicate a small settlement/farmstead of later date (sites 14-16). In general, the number of finds is low, amounting to a dozen or so pottery fragments (Fig. 38; Pl. 41). At present we are not able to date these small repertoires more precisely, but would, in general, suggest a possible late 1st millennium BC production or later.

Apart from site identified as a result of dispersal of potsherds (see S. Mazzoni, this volume, § 3.3), the only other finds were the Hittite worked stone and the column and capital in the garden of the mosque of Aşağı Karakaya Köy probably of Late Roman/Byzantine date (Pl. 13: 5). Collections of surface material were not carried out because not present.

A conic formation located on the natural terrace south of Uşaklı was visited and at first interpreted as a possible *tumulus*. It had been illegally excavated in recent times and, although the morphology is typical of *tumuli* it would appear, in fact, to be a natural formation, as indicated by our geologists.

3.1 Taşlık Höyük (site no. 3)

The mound is about 2 km SW of Uşaklı Höyük between the villages of Büyük and Küçük Taşlık, on a rocky spur, partially cut through by modern track (Pl. 14: 1). The site is in the gazetteer of the surveyed sites in the framework of the Kerkenes and Alişar projects (Summers, Summers 1994: 49; Summers *et al.* 1995: 59-61; Gorny 1995: plate V) and was mentioned in reports of previous expeditions (Von der Osten 1937c: Map III, between Yukarı and Aşağı Taşlık; Cornelius 1964: 12 n. 4; Meriggi 1971: 62-63). The mound overlooks the plains to the west and a narrow valley set among rocks where the Kötü Dere stream flows. There is also a spring not far from the site. There are shallow holes on the top of the mound, probably the results of modern activities to remove soil or illicit diggings.

On the surface of the site and in correspondence to the section exposed during the building of the modern road a random sample of sherds were collected³³⁶. The repertoire consists mainly of fragments of conical and curved handmade bowl and jars (Fig. 37; Pl. 39). Chaff and grit tempers with few lime inclusions are the most typical and burnishing of the outer and inner surfaces is documented in the majority of the sherds collected. In a few cases we noted traces of a painted red band applied on the rim. We classified two groups of tempers on the basis of the prevailing inclusions: the first is mainly grit tempered and the second chaff tempered. The sherds show various colours, from dark brown and dark grey to buff, red and orange.

Bowls are characterised by irregular profiles and mouth, irregular thickness and cracked surfaces; in some case there is thin slip covering in some cases the inner side and rim of the open shapes.

Horizontal, vertical but also both and oblique burnishing traces (Fig. 37: 703) are documented; the open shapes are burnished both inside and out. In one case a dark painted band covers the outer surface of a closed form body sherd (Pl. 39: 08.17). Some grit-tempered specimens are black in colour with some buff/yellow nuances on the outer side (Pl. 39: 08.7).

Usually the sherds are thick and coarse. Conical bowls with simple rims recall forms from Alaça EBA I level (formerly considered Chalcolithic) and Alişar³³⁷. There are have red to light brown inside and darker on the external surface; or reddish inside and light brown outside (for example Pl. 39: 08.3;

³³⁶ A discrete number of pottery sherds were visible on the surface and at the base of the section. During an initial visit, we picked up a selection of 18 sherds from the section and 25 from the surface of the mound.

³³⁷ Von der Osten 1937a: specimens in Fig. 174.

08.21). A single row of small fingernail impressions is documented on the shoulder of one specimen (Pl. 39: 08.14). The use of fingernail motifs as a decorative pattern is attested at Alaça³³⁸, but often in multiple lines or disposed randomly on the body (the single line is documented, but rare); and a roughly similar example to our specimen has been found at Büyükkale³³⁹.

Rough parallels for the andiron found on the north-western slope (Fig. 37: 705; Pl. 39: 08.18) can be found at Mercimektepe³⁴⁰.

Some traits of the repertoire are shared with different assemblages dating from the Middle Chalcolithic to the EBA. Black and dark grey were the predominant colours of ceramics in the Middle Chalcolithic and earlier phases of the Late Chalcolithic period in the second half of the 4th millennium BC (Steadmann *et al.* 2008: 63) but the reddish colours are also attested in the same levels. The red pottery is characteristic of the EBA level of the Cıradere assemblage³⁴¹; here for example parallels could be found for our nos 697, 693, 696³⁴². Simple shapes characterised by brown and blackish burnished surfaces, mineral tempers with mica and limestone could also be dated to the Late Chalcolithic. Furthermore we cannot exclude the possibility that the shape and red slip coat on the inside (Fig. 39: 08.3) as well as the beige colour of some types (Fig. 39: 08.21) could betray some similarity also with specimens of the Late Chalcolithic horizon of the Yarikkaya plateau³⁴³, but this would only be a generic comparison. Also the red/orange slip (Pl. 39: 08.21) and grey slip (Pl. 39: 10, K09.1020) recall the EBA I tradition (Orthmann 1963b: 16-17). Only four sherds (Pl. 39: pictures at the bottom; Fig. 37: 706 and 707) are wheelmade and to be assigned to the 1st millennium BC production.

The dimension and position of Taşlık fit well with the reconstruction of the typical site of earlier farmers who moved into central Anatolia suggested by U.D. Schoop in relation to the Büyükkaya settlement (2005a: 24). In fact, Taşlık also is a small site on a rock outcrop, in an elevated location, at the margins of the plain and close to a stream in a steep gorge.

It is worth mentioning here that there are no close links between the repertoires of Taşlık and Uşaklı. The darker colours and coarser fabrics of plant-tempered specimens, the different texture of grit fabrics and the rough surfaces as well as the predominance of the conical profile and the absence of hole-mouth types are all elements which differ from the characteristics of the handmade repertoire of Uşaklı. Apparent similarities are to be found in pieces with red and blackish outer surfaces (Pl. 15: 8, K12.1092, K12.135 and Pl. 39: 08.28). However the result of our limited collection of sherds confirms the hypothesis advanced by other scholars that the site was first occupied in the Late Chalcolithic and in the Early Bronze Age, with sparse evidence dating to the later periods (Iron-Age, Achaemenid) (Summers *et al.* 1995: 60-61).

3.2 Aşağı Karakaya Höyük (site no. 9)

The hilltop site 9 is situated east of Aşağı Karakaya Köy, about 2km north of Uşaklı Höyük, in prominent position and with clear views in all directions (Pl. 14: 2). This village has been mentioned in previous reports thanks to the presence in the garden of the local mosque of a well dressed granite slab, probably Hittite and some stone architectural elements, in particular a column and a capital (Pl. 13: 5). Other fragmentary materials, mainly dressed stones, have been reused as construction materials in the modern houses. The site³⁴⁴, apparently not previously mentioned in other reports, overlooks the plain where Uşaklı is located and consists of a small mound on the undulating hills marking the passage between the plateau north of the Yozgat-Sorgun highway and the valley of the Egri Öz river. A remarkable scattering of sherds has been observed around this small mound and on the slopes of the natural hills nearby. Apparently no roof tiles are visible on the surface and the erosion of the archaeological deposit is profound. A layer of incoherent soil covers the top of the southern hill. Sampling survey units were established on the basis of the morphological features of the site. The density of sherds varies from a low rate along the perimeter of the two natural hills at the base of the anthropic deposit, to a high rate in the depression at the centre of the site and north of the mound. Here rock outcrops emerge on the surface. On the top of the mound a circular hole is visible, probably caused by illegal *tumuli* diggers.

³³⁸ Arık 1937: Lev. LXXXI: Al. 705; Koşay 1938. Lev. LXXXVIII-VII.

³³⁹ Fischer 1963: taf. 8: 115-116.

³⁴⁰ Özcan 1993: Fig. 9 – B.

³⁴¹ Hachmann 1957: 61, 63, 65; taf. 37.

³⁴² Hachman 1957: Fig 37: 17, 24, 4.

³⁴³ Schoop 2005b: taf. 24-25.

³⁴⁴ Dimensions: 48x55m.

The repertoire of collected sherds belonging to pots for transport, storage, table and kitchen, includes utilitarian medium-coarse mineral ware of rough reddish texture (very close to what was first identified as 'Brittle Ware'³⁴⁵), some specimens of painted ware and white slipped ware (Figs. 39-40; Pl. 40). This composition of the pottery repertoire as well as the occurrence of punctuated patterns on handles and wavy line decorations, mirror the picture emerging from Çadır (Gorny *et al.* 1995: 80) where these particular productions have been considered diagnostic for the Byzantine period (the date proposed is late 6th century AD). Thin-walled wheel thrown pots, vertical strap handles, horizontal wheel ridging, hard coarse-gritty reddish fabrics, medium mineral inclusions and limestone all are elements diagnostic of the Early Byzantine period of the Byzantine Dark Age (c. 7th-8th centuries AD). Instead, wavy incised decorations and jugs with narrow neck are recurring characteristics of the Middle Byzantine production of 10th-12th centuries AD (Vionis *et al.* 2009). However the wavy line decorations on sherds collected in the Tavium survey³⁴⁶ have been considered as early Byzantine, indicating the persistence of some decorative forms over lengthy periods.

The thin walls and carination angles of the narrow necked jars often with strap handles and ribbed neck of nos 730-731 (Fig. 39) could be compared with types from Saraçhane in distant Istanbul³⁴⁷. Finger indentations are also documented (Haynes 1992: Fig. 84: 54) as well as bowls similar to our no. 718 (Fig. 39)³⁴⁸, but glazed. The rim of this last type finds parallels with specimens in red paste found in Iznik and dated to the 14th-17th century AD (Özkul 2001: 374). Several elements of these jugs with conical mouth, in particular the corrugated thin walls, are similar to the containers for oil and wine found in Elaiussa Sebaste, and dated to between 5th and 7th centuries AD (Ferrazzoli, Ricci 2010; Burragato *et al.* 2007: 690), the so-called Late Roman I amphorae, widespread in the Eastern Mediterranean and identified probably with the *serioale* considered by Isidore of Seville as *Cilicienses*³⁴⁹. The main difference is in the shape of the handles which are usually squat and with longitudinal finger impressions in LRI amphorae but flat strap like in our cases³⁵⁰. Carinated walls decorated with lightly impressed wavy lines (Fig. 40: 438-9; Pl. 39: 2) and ridges with rows of X shaped hatch impressions (Pl. 39: 5; Fig. 40: 739) belong to different types of vessels for which it is hard to find appropriate parallels. Something vaguely similar is found at Tille Höyük³⁵¹ dating to the medieval period (13th century AD). A kind of handle decorated with shallow grooves along either side and similar to our handle no. 734 (Fig. 39), but with crescent shaped incisions at the centre, has been found in Late Roman/Byzantine levels at Kilise Tepe (Jackson 2007: Fig. 428: no. 1429) where fabrics and some morphological elements, such as the relatively thin walls and broad flat handles, furnish a general parallel for our repertoire (Jackson 2007: 404; and wavy line in Fig. 428: no. 1419). Large bowls with deep notches cut into the lower edge of the upright rim have no parallels, o my knowledge.

To sum up, it is extremely difficult to date such a repertoire given that most of the sherds are from standard and coarse kitchenware. Moreover the absence of stratified sites in the area covering this long span of time of the Common Era make any accurate dating even harder, apart from some very general indications. Although firm evidence for developing a precise chronology for the settlement was not found, we propose here, in broad terms, that the main period of occupation was between the Late Roman and the Byzantine Period. Given the limited and generic evidence used as parallels for dating, only preliminary suggestions can be here offered for a chronological evaluation of the repertoire. The sherd in fine red-slip ware is an element that could be perhaps linked to a local manufacture derived from the Late Roman tradition. On the basis of a few, sporadic elements for comparison, we can preliminarily suggest that the earliest phase of occupation probably dates from the Late Antique or Early Byzantine period, with most of the materials being from the Early/Middle Byzantine period, approxi-

³⁴⁵ Brittle Ware is a thin walled ware for domestic purposes widely distributed in Northern Syria and Iraq on military sites, from the 2nd to 7th century AD (peak in 6th-7th century AD), of probable Syrian origin. Continuity in this production between the Roman and Abbasid periods has been documented. In general pottery made with iron-rich clay with sand inclusions, wheelmade and high fired is widespread in the eastern Mediterranean basin, from the Hellenistic to the Omayyad period. Necked jars, with narrow mouth (around 8-15cm) and kitchen pots are the most frequently recurring types.

³⁴⁶ Strobel, Gerber 2000: Fig. 16d.

³⁴⁷ Haynes 1992: Fig. 84: 45, 50.

³⁴⁸ Haynes 1992: Fig. 84: 46.

³⁴⁹ Ricci 2007: Fig. 2: 13; Fig. 3: 16.

³⁵⁰ These kinds of flat handles vaguely recall those of coking pots of probable Cypriot origin (Ferrazzoli, Ricci 2007: Fig. 6-7), dating to 6th-7th century AD.

³⁵¹ Moore 1993: Fig. 35: 77, 81.

mately 8th-11th century AD³⁵². The small settlement, located on top of a natural hill, may well have been a guard post (watchtower?) or control station related to the main site of Uşaklı. It is worth mentioning here that the importance of Uşaklı and its satellite posts is due to the important communications routes which crossed this territory, connecting the eastern and western regions of the Central Plateau and in use from Roman times until the Ottoman period. The *Tabula Peutingeriana* shows that the main *Tavium* (Büyük Nefes Köy)-*Sebasteia* (Sivas) route intersects in the vicinity of Sorgun (formerly Yeşilova and Büyük Köhne) with another route leading toward north-west and connecting Zile and the Black Sea with Kayseri, ancient *Caesarea*. Traces of this road have been discovered in the area of Alişar (Von der Osten 1933: 116). Furthermore, roads designed for wheeled traffic are documented east of *Tavium* (Mitchell 1993: map 8), one of the key points in the eastern part of the road system (Mitchell 1993: 129), attesting to the importance of sites along the main arterial and secondary tracks with settlements and watchtowers developed in connection with these. The web of routes was in use in the early 7th century AD and probably continued to be so down to the Ottoman period. The exploitation of land for agricultural purposes and the closeness of important routes were the main factors that ensured the success of the settlement in this undulating landscape for centuries.

4. Concluding remarks

Results from the intensive survey yielded information of great importance in relation to the settlement history of the site.

The main aim of UHSP was to obtain firm data that would enable us to study in detail the occupational sequence and obtain an areal scattering of the superficial archaeological evidence. However the complete occupation sequence of the site and its surrounding area cannot be obtained through surveying, even if intensive, and only intermittent evidence has been highlighted. Similarly, determining the chronology of the repertoire of materials proves to be a far more complex task than we had initially presumed.

The attempt to determine more precise and finer scale details regarding the settlement sequence has met with only minimal success. Chronology remains an unsolved and rather problematic aspect in relation to the Central Anatolian plateau and a more reliable pottery chronology is essential if we hope to provide a more precise interpretation of the survey data, especially with regard to Proto-historic and Post-Roman studies. However, in order to construct a valid ceramics sequence we need to excavate small, relatively short-lived sites on virgin soil for different periods and stratified layers unaffected by major rearrangement during and after phases of abandonment or settlement crises. These contexts, which could provide us with a well-defined short segments of the regional pottery horizon are, as yet, still lacking in the area.

The survey provided us with the first pieces of systematic information about the occupational history of the mound. Analysis of the finds suggests that the site was mainly occupied from the end of the Early Bronze Age to the Late Roman/Byzantine period, with an intensive occupation during the 2nd millennium BC. Sporadic traces of an earlier occupation dating to the Chalcolithic and early EBA have also probably been identified. Apart from at Uşaklı Höyük, up until now very limited evidence dating to the Chalcolithic or the first part of the EBA has been found. There is also an apparent absence of late 3rd, 2nd and 1st millennium sites and sparse presence of Late Roman/Byzantine date. We do not know whether this is a true pattern, or only the result of the inappropriate methodology of the archaeological research having been applied in this characteristic geographic and anthropic setting.

Surface collecting produced many ceramic types that we can hardly consider chronological markers of a given century as they are represented in 2nd millennium assemblages of all periods. This difficulty is encountered with sherds of red slip, for example, and some types of vessels that continued to be in use from the MBA until the end of LBA. It is often difficult to make a clear distinction between the different phases of the 2nd and 1st millennium and, at the moment, we cannot assert that our generic sherds in red slip ware belong to the MBA and LBA horizon rather than of the IA. We can only highlight the fact that the majority of the diagnostic sherds seem to have good parallels with types found at MBA-LBA sites. In many cases, however, this does not exclude the possibility that they may, instead, pertain to the IA horizon. If we look at the scattering of single categories we can observe that some categories

³⁵² Thanks go to Marica Cassis for her remarks and useful indications concerning the repertoire and its possible date.

that can be dated firmly to the 2nd millennium tend to occur on the same portions of the site (i.e. the low slopes of the terrace and the scraped slope of the high mound). It is also difficult to identify clear markers in plain ware which was, without doubt, used exclusively in the LBA or in the IA, apart from a few specimens. In this way the bulk of the materials can be assigned only to a lengthy time-span and is cannot be used to date any single phase of use during the long history of the settlement.

The correspondence of 2nd millennium sherds and some buried structures identified by the geomagnetic survey can hardly be considered fortuitous. In particular, the density of drab ware diagnostic sherds over a limited area of the northern and eastern slopes (collecting units F19-20 and lot 2, bands 2, 4; lot 3, bands 2-3), may suggest, as a preliminary consideration, that architectural remains appearing beneath the surface might belong to the LBA period. A notable density of drab Ware sherds was found at the foot of high mound and there, again, within the sequence of occupation, we have to expect some remains dating to the same period. Red slip ware was found fairly evenly across the entire mound with a major density on the south-eastern slopes of the terrace (lots 1-4), where a fair number of diagnostic sherds, dating from the *karum* to the Imperial Hittite period, are also mainly distributed. On the basis of our analysis, the 2nd millennium settlement covered most of the terrace.

Handmade sherds, probably to be dated to the transitional period between EBA and MBA, have been found mainly on the terrace with a noteworthy concentration at the foot of the high mound and at the base of the northern terrace slope. Instead, the later sherds are homogeneously dispersed over the terrace and in part on the slope of the höyük.

The middle and late IA occupation is well documented by many types of sherds. Just how new the IA occupation is still unclear, but no handmade EIA materials similar to the Boğazköy assemblage have been recognised in Uşaklı to date.

We can identify some interesting concentrations and general trends in the scattering of materials. This means that in some sectors we stand a fair chance of finding architectural remains dating to one or another chronological period or to indicating a specific function.

The combined occurrence of wares and ceramic types of late periods together with tiles suggests that the presence of 'late' structures has to be located mostly in the northern and western portions of the terrace, and in the north-eastern squares with regard to the area occupied by Building I. Here the higher consistency of later layers prevents the 2nd millennium sherds to come to light, apart from those from the lower slope of the high mound in part cut by ploughing or which have shifted from nearby eastern squares. On the other hand, in the north eastern and eastern squares and units, the 2nd millennium is better documented by sherds, suggesting that any significant structures under the surface are to be assigned preliminarily to this period. The portions of the mound slope that have been scraped returned a good sample of types, including also handmade sherds of earlier date. Given the slope of the topsoil, it is obviously hard to determine a more finely-tuned chronological differentiation of the different collections. It is worth mentioning that the occurrence of those types we considered of 1st millennium date or later, such as painted IA and Roman/Byzantine, is relatively low compared to in other parts of the mound. This suggests that the sequence of later periods are not of principal or exclusive importance in the history of occupation of the high mound, and that here the 2nd millennium layers are also of a certain relevance.

Whilst the scattering patterns of different sets of samples could pertain to unconnected events, it is more likely that they represent the faint remains of layers below the surface relating to the various phases of occupation differently documented in different zones of the site.

The UHSP was intended primarily to understand the main phases of occupation of the site, to collect basic information on the distribution of the surface evidence, with the surrounding area a secondary aim that will require wider and more in-depth exploration. A general picture has, however, been drawn and interesting results achieved although a complete understanding of the area remain to be achieved since many fields were left outside the area of our activities because cultivated. Our fieldwork, although systematic and intensive, leaves many doubts regarding a reconstruction of the chronology of the settlement and many gaps will have to be filled in during future work. However, by reference to the data at hand and published in this report we hope to encourage debate about the archaeological relevance of settlement in this part of the Central Plateau through evidence attested on the surface.

Many outstanding questions remain and others have been raised by the UHSP but we hope the results obtained will contribute to a better understanding of settlement processes on the Central Anatolian Plateau. However only systematic excavations will be able to validate our reconstruction and confirm whether scatters of archaeological evidence reflect real settlement patterning and, more generally, throw light on the occupation of Uşaklı Höyük and the upper course of the Eğri Oz Dere.

References

- Arik R.O. 1937, *Alaca Höyük Hafriyatı. 1935 deki çalışmalara ve keşiflere ait ilk rapor* (Türk Tarih Kurumu Yayınlarından V. Seri – no. 1), Türk Tarih Kurumu, Ankara.
- Arnhold S. 2009, *Das hethitische Gebäude E auf der Akropolis von Kuşaklı* (Kuşaklı-Sarissa Band 4), Verlag Marie Leidorf GmbH, Rahden/Westf.
- Ascalone E., Peyronel L. 2011, *Studi italiani di metrologia e economia de Vicino Oriente Antico dedicati a Nicola Parise in occasione del suo settantesimo compleanno*, Herder Libreria Editrice, Roma.
- Barracough A. 1992, *Quaternary sediment analysis: a deductive approach at A-level*, «Teaching Geography», 17: 15-18.
- Bittel K. 1937, *Bogazköy. Die Kleinfunde der Grabungen 1906-1912 I: Funde hethitischer Zeit* (Wissenschaftliche Veröffentlichung der Deutschen Orient-Gesellschaft 60), J.C. Hinrichs Verlag, Leipzig.
- Bittel K. 1970, *Hattusha. The Capital of the Hittites*, Oxford University Press, New York.
- Bittel K. 1974, *Bemerkungen zur Sogenannten galatischen Keramik, Mansel'e Armağan. Mélange Mansel* (Türk Tarih Kurumu Yayınları Dizi VII – Sa. 60), Ankara, Türk Tarih Kurumu Basımevi, Ankara: 227-237 (vol. I) and 87-92 (vol. III).
- Bittel K., Güterbock G. 1935, *Boğazköy. Neue Untersuchungen in der hethitischen Hauptstadt* (Abhandlungen der Preussischen Akademie der Wissenschaften. Philosophisch-Historische Klasse, 1), Akademie der Wissenschaften, Berlin.
- Boehmer R.M. 1972, *Die kleinfunde von Boğazköy. Aus den grabungskampagnen 1931-1939 und 1952-1969* (Wissenschaftliche Veröffentlichung der Deutschen Orient-Gesellschaft 87, Boğazköy-Hattuša: Ergebnisse der Ausgrabungen VII), Gebr. Mann Verlag, Berlin.
- Boehmer R.M. 1979, *Die kleinfunde aus der Unterstadt von Boğazköy. Grabungskampagnen 1970-1978* (Boğazköy-Hattuša: Ergebnisse der Ausgrabungen X), Gebr. Mann Verlag, Berlin.
- Boehmer R.M., Güterbock H.G. 1987, *Glyptic aus dem Stadtgebiet von Boğazköy. Grabungskampagne 1931-1939, 1952-1978*, (Boğazköy-Hattuša: Ergebnisse der Ausgrabungen XIV), Verlag Philipp von Zabern, Berlin.
- Bossert E.-M. 2000, *Die keramik phrygischer zeit von Boğazköy: Funde aus den Grabungskampagne 1906, 1907, 1911, 1921, 1931-1939 und 1952-1960* (Boğazköy-Hattuša: Ergebnisse der Ausgrabungen XVIII), Verlag Philipp von Zabern, Mainz am Rhein.
- Burrigato F., Di Nezza M., Ferrazzoli A.F., Ricci M. 2007, *Late Roman 1 Amphora Types produced at Elaiussa Sebaste*, in M. Bonifat, J.-C. Trégliä, *LRCW2. Late Roman Coarse Wares, Cooking Wares and Amphorae in the Mediterranean World. Archaeology and Archaeometry*, vol. II, BAR Int. Series 1662, Archaeopress, Oxford: 689-700.
- Cassis M. 2009, *Çadır Höyük: A Rural Settlement in Byzantine Anatolia*, in T. Vorderstrasse, J. Roodenberg (eds.), *Archaeology of the Countryside in Medieval Anatolia*, Nederlands Instituut voor het Nabije Oosten, Leiden: 1-24.
- Cornelius F. 1964, *Zur hethitischen Landeskunde. Ergebnisse der 2. W. Esch-Expedition 1962*, «Bibliotheca Orientalis», 21: 11-15.
- Dupré S. 1983, *Porsuk I. La céramique de l'Age du Bronze et de l'Age du Fer*, Éditions Recherche sur les civilisations, «Mémoire n° 20», Paris.
- Eriksson K.O. 1993, *Red Lustrous Wheelmade Ware* (Studies in Mediterranean Archaeology 103), Paul Åströms Förlag, Jonsered.
- Ferrazzoli A.F., Ricci M. 2007, *Elaiussa Sebaste: produzioni e consumi di una città della Cilicia tra V e VII secoli*, in M. Bonifat, J.-C. Trégliä, *LRCW2. Late Roman Coarse Wares, Cooking Wares and Amphorae in the Mediterranean World. Archaeology and Archaeometry*, vol. II, BAR Int. Series 1662, Archaeopress, Oxford: 671-688.
- Ferrazzoli A.F., Ricci M. 2010, *Un centro di produzione delle anfore LRi: Elaiussa Sebaste in Cilicia. Gli impianti, le anfore*, in S. Menchelli, S. Santoro, M. Pasquinucci, G. Guiducci (eds.), *LRCW3. Late Roman Coarse Wares, Cooking Wares and Amphorae in the Mediterranean. Archaeology and archaeometry Comparison between western and eastern Mediterranean*, vol. II, BAR Int. Series 2185, Archaeopress, Oxford: 815-826.
- Fındık N. Özkül 2001, *İzniik Tiyatrosu Kazı Buluntuları (1980-1995) Arasındaki. Osmanlı Seramikleri*, T.C. Kültür Bakanlığı, Ankara.
- Fındık N. Özkül 2003, *Turkish Glazed Pottery*, in C.S. Lightfoot (ed.), *Amorium Reports II. Research Papers and Technical Reports*, BAR Int. Series 1170, Archaeopress, Oxford: 105-118.

- Fischer F. 1963, *Die hethitische Keramik von Bogazköy*, Boğazköy-Ḫattuša 4 (Wissenschaftliche Veröffentlichung der Deutschen Orient-Gesellschaft 75), Gebr. Mann Verlag, Berlin.
- Gates M.-H. 2001, *Potmarks at Kinet Höyük and the Hittite Ceramic Industry*, in É. Jean, A.M. Dinçol, S. Durugönül (éds.), *La Cilicie: espaces et pouvoirs locaux (2e millénaire av. J.-C.-4e siècle ap. J.-C.)*. Actes de la Table ronde internationale d'Istanbul, 2-5 novembre 1999 (Varia Anatolica XIII), De Boccard/Ege Yayınları, Istanbul/Paris: 137-157.
- Gates M.-H. 2006, *Dating the Hittite Levels at Kinet Höyük: a Revised Chronology*, in D.P. Mielke, U.-D. Schoop, J. Seeher (eds.), *Strukturierung und Datierung in der hethitischen Archäologie* (BYZAS 4, Veröffentlichungen des Deutschen Archäologischen Instituts Istanbul), Ege Yayınları, Istanbul: 293-309.
- Genz H. 2001, *Iron Age pottery from Çadır Höyük*, «Anatolica», 27: 159-170.
- Genz H. 2003, *The Early Iron Age in Central Anatolia*, in B. Fischer, H. Genz, É. Jean, K. Köroğlu (eds.), *Identifying Changes: the Transition from Bronze to Iron Ages in Anatolia and its Neighbouring Regions*, *Proceedings of the International Workshop, Istanbul, November 8-9, 2002*, Türk Eskiçağ Bilimleri Enstitüsü, Istanbul: 179-191.
- Genz H. 2004, *Büyükkaya. I. Die Keramik der Eisenzeit. Funde aus den Grabungskampagnen 1993 bis 1998* (Boğazköy-Ḫattuša: Ergebnisse der Ausgrabungen XXI), Philipp von Zabern, Mainz.
- Genz H. 2007, *Kızılırmak Bölgesi'nde Demir Çağı/The Iron Age in the Kızılırmak Region*, in H. Sivas, T. Tüfekçi Sivas (eds.), *Friglerin Gizemli Uygarlığı/The Mysterious Civilization of the Phrygians*, Kultur ve Turizm Bakanlığı & Yapi Kredi Yayınları, Istanbul: 127-140.
- Genz H. 2011, *The Iron Age in Central Anatolia*, in G.R. Tsetschladze (ed.), *The Black Sea, Greece, Anatolia and Europe in the First Millennium BC*, *Colloquia Antiqua* 1, Walpole MA, Peeters, Leuven, Paris: 331-368.
- Gorny R.L. 1995, *Alisar Höyük in the Late Second Millennium B.C.*, in O. Carruba, M. Giorgieri, C. Mora (eds.), *Atti del II. Congresso internazionale di Hittitologia* (Studia Mediterranea 9), Gianni Iuculano Editore, Pavia: 159-171.
- Gorny R.L., McMahon G., Paley S., Kealholder L. 1995, *The Alışar Regional Project 1994*, «Anatolica», 21: 65-100.
- Hachmann R. 1957, *Prähistorische Funde von Ciradere*, in K. Bittel, R. Naumann, Th. Beran, R. Hachmann, R., G. Kurth (eds.), *Boğazköy III, Funde aus den Grabungen 1952- 1955* (Ausgrabungen der Deutschen Orient-Gesellschaft und des Deutschen Archäologischen Instituts, Abhandlungen der Deutschen Orient-Gesellschaft 2), Gebr. Mann Verlag, Berlin: 62-66.
- Hagstrum M.B., Hildebrand J.A. 1990, *The Two-Curvature Method for Reconstructing Ceramic Morphology*, «American Antiquity», 55 (2): 388-403.
- Hayes J.W. 1992, *Excavations at Saraçhane in Istanbul, vol 2: The Pottery*, Princeton University Press, Princeton.
- Hendrix R.E., Drey P.R., Storffell J.B. 1996, *Ancient pottery of Transjordan: an introduction utilizing published whole forms, late Neolithic through late Islamic*, Institute of Archaeology/Horn Archaeological Museum, Andrews University Press, Berrien Springs, MI.
- Hüser A. 2007, *Hethitische Anlagen zur Wasserversorgung end Entsorgung* (Kuşaklı-Sarissa Band 3), Verlag Marie Leidorf GmbH, Rahden/Westf.
- Jackson M.P.C. 2007, *Pottery from level 1*, in N. Postgate, D. Thomas (eds.), *Excavations at Kilise Tepe 1994-1998. From Bronze Age to Byzantine in western Cilicia* (BIAA Monograph no. 30), British Institute at Ankara, Ankara: 387-427.
- Korbel G. 1985, *Die spätbronzezeitliche Keramik von Norşuntepe*. Hanover
- Koşay H.Z. 1938, *Türk Tarih Kurumu tarafından yapılan Alaca Höyük hafriyatı 1936 Daki Çalışmalara Keşiflere Ait İlk Rapor* (Türk Tarih Kurumu Yayınlarından V. Seri - n. 2), Türk Tarih Kurumu, Ankara.
- Koşay H.Z., Akok M. 1951, *Alaca Höyük Kazısı. 1937-1939 Daki Çalışmaları ve Keşiflere Ait İlk Rapor. Les fouilles d'Alaca Höyük enterprises pa la Societe d'Histoire Turque. Rapport preliminaire sur les travaux en 1937-1939*, Türk Tarih Kurumu Basımevi, Ankara.
- Koşay H.Z., Akok M. 1957, *Büyük Güllücek Kazısı. 1947 ve 1949 Daki Çalışmalar Hakkında İlk Rapor. Ausgrabungen von Büyük Güllücek. Ausgeführt durch die Türkische Historische Gesellschaft. Vorbericht über die arbeiten von 1947 und 1949*, Türk Tarih Kurumu Basımevi, Ankara.
- Koşay H.Z., Akok M. 1966, *Türk Tarih Kurumu tarafından yapılan Alaca Höyük kazısı. 1940-1948 deki çalışmalara ve keşiflere ait ilk rapor / Ausgrabungen von Alaca Höyük. Vorbericht über die Forschungen und Entdeckungen von 1940-1948* (Türk Tarih Kurumu Yayınlarından V. Seri - Sa. 6), Türk Tarih Kurumu, Ankara.

- Koşay H.Z., Akok M. 1973, *Alaca Höyük Kazısı. 1963-1967 Çalışmaları ve Keşiflere Ait İlk Rapor. Alaca Höyük Preliminary Report on Research and Discoveries 1963.1967*, Tür Tarih Kurumu Basımevi, Ankara.
- Kozal E. 2003, *Analysis of the Distribution Patterns of Red Lustrous Wheelmade Ware, Mycenaean and Cypriot Pottery in Anatolia in the 15th-13th century B.C.*, in B. Fisher, H. Genz, É. Jean, K. Köroğlu (eds.), *Identifying Changes. The Transition from Bronze to Iron Age in Anatolia and its Neighboring Regions. Proceedings of the International Workshop, Istanbul, November 8-9, 2002*, Türk Eskiçağ Bilimleri Enstitüsü, Istanbul: 65-78.
- Maier F. 1963, *Bemerkungen zur sogenannten galatischen Keramik von Boğazköy*, «Jahrbuch des Deutschen Archaeologische Instituts», 78: 218-255.
- Manuelli F. 2009, *Local Imitations and Foreign Imported Goods. Some problems and new questions on Red Lustrous Wheelmade Ware in the light of the new excavations of the Southern Step Trench at Yumuktepe/Mersin*, «Altorientalische Forschungen», 36 (2): 251-267.
- Matsumura K. 2005, *Die eisenzeitliche keramik in Zentralanatolien aufgrund der Grundlage der Ausgrabung von Kaman-Kalehöyük*, PhD Dissertation, Freie Universität Berlin.
- Meriggi P. 1971, *Ottavo e ultimo viaggio anatolico*, «Oriens Antiquus», 10: 57-66 (Pls. VII-XVIII).
- Mielke D.-P. 2006, *Die Keramik vom Westhang, Kuşaklı-Sarissa 2*, Marie Leidorf GmbH, Rahden-Westphalia.
- Mielke D.-P. 2007, *Red Lustrous Wheelmade Ware from Hittite Contexts*, in I. Hein (ed.), *The Lustrous Wares of Late Bronze Age Cyprus and the Eastern Mediterranean (Papers of a Conference, Vienna, 5th-6th of November 2004)* (Contributions to the Chronology of the Eastern Mediterranean 13), Verlag der Österreichischen Akademie der Wissenschaften, Vienna: 155-168.
- Mitchell S. 1993, *Anatolia. Land, Men and Gods in Asia Minor*, Clarendon Press, Oxford.
- Moore J. 1993, *Tille Hoyuk 1. The medieval period* (BIAA Monograph n. 14), British Institute at Ankara, Ankara.
- Müller-Karpe A. 1988, *Hethitische Töpferei der Oberstadt von Hattuša: ein Beitrag zur Kenntnis spät-grossreichszeitlicher Keramik und Töpferbetriebe unter Zugrundelegung der Grabungsergebnisse von 1978-82 in Boğazköy* (Marburger Studien zur Vor- und Frühgeschichte, band 10), Hitzeroth Verlag, Marburg/Lahn.
- Munsell Color 2000, *Munsell soil color charts, years 2000 washable edition*, Munsell Color X-Rite, Grand Rapids, Michigan.
- Neve P. 1982, *Büyükkale. Die Bauwerke. Grabungen 1954-1966*, Boğazköy-Hattuša 12, Gebr. Mann, Berlin.
- Newel E.T. 1931, *The Küçük Köhne Hoard* (Numismatic Notes and Monographs no. 46), American Numismatic Society, New York.
- Öktü A. 1973, *Die Intermediate-Keramik in Kleinasien* (PhD dissertation, Freie Universität Berlin), W.u.J.M. Salzer, München.
- Orthmann W. 1963a, *Frühe keramik von Boğazköy aus den Ausgrabungen am Nordwesthang von Büyükkale* (Wissenschaftliche Veröffentlichung der Deutschen Orient-Gesellschaft 74, Boğazköy-Hattuša: Ergebnisse der Ausgrabungen III), Gebr. Mann Verlag, Berlin.
- Orthmann W. 1963b, *Die Keramik der frühen Bronzezeit aus Inneranatolien* (Istanbuler Forschungen, Band 24), Gebr. Mann Verlag, Berlin.
- Orton C., Hughes M. 2013, *Pottery in Archaeology* (2nd edition; kindle edition), Cambridge University Press, New York.
- Özcan M. 1993, *Yozgat Mercimektepe Höyüğü 1991 Yılı Kurtarma Kazısı, 3. Kurtarma Kazıları Semineri (27-30 Nisan 1992 Efes)*, Kültür Bakanlığı, Anıtlar ve Müzeler Genel Müdürlüğü, Ankara.
- Özgüç T. 1999, *Kültepe-Kaniş/Neša saraylari ve mabetleri. The palaces and temples of Kültepe-Kaniş/Neša* (Türk Tarih Kurumu Yayınlarından V-46), Türk Tarih Kurumu Basımevi, Ankara.
- Özsait M., Özsait N. 2003, *La céramique dite "galate" du basin du Kızıllırmak*, «Anatolia Antiqua», 11: 323-342.
- Parzinger H., Sanz R. 1992, *Die Oberstadt von Hattuša: hethitische Keramik aus dem zentralen Tempelviertel. Funde aus den Ausgrabungen 1982-1987* (Boğazköy-Hattuša: Ergebnisse der Ausgrabungen XV), Mann Verlag, Berlin, Gebr.
- Parzinger H. 1993, *Zur Zeitstellung der Büyükkaya-Ware: Bemerkungen zur vorbronzezeitlichen Kulturfolge Zentralanatoliens*, «Anatolica» 19: 211-29.
- Poblome J. 1999, *Sagalassos Red Slip Ware. Typology and Chronology*, Brepols, Turnhout.

- Powroznik K.J. 2010, *Die Eisenzeit in Kuşaklı* (Kusakli-Sarissa Band 5), Verlag Marie Leidorf GmbH, Rahden/Westf.
- Ricci M. 2007, *Elaiussa Sebaste: context, production and commerce*, in B. Bohlendorf-Arslan, A.O. Uysal, J. Witte-Orr (eds.), *Late antique and Medieval pottery and tiles in Mediterranean archaeological contexts: Proceedings of the First International Symposium on Late Antique, Byzantine, Seljuk, and Ottoman pottery and tiles in archaeological contexts (Canakkale, 1-3 June 2005)* (BYZAS 7, Veröffentlichungen des Deutschen Archäologischen Instituts Istanbul), Ege Yayinlari/German Institute of Archaeology, Istanbul: 169-180.
- Rice P.M. 1987, *Pottery Analysis. A Sourcebook*, University of Chicago Press, Chicago-London.
- Rova E. 2003, *The Third Millennium Pottery Morphology. The Typology Principles, The Coding System, and Some Preliminary Results*, in M. Lebeau, A. Suleiman (eds.), *Tell Beydar, the 1995-1999 seasons of excavations. A preliminary report* (Subartu 10), Brepols, Turnhout: 395-490.
- Rye O.S. 1981, *Pottery Technology: Principles and Reconstruction*, Taraxacum, Washington D.C.
- Sazanov A. 2007, *Les amphores orientales d'époque protobyzantine au nord de la Mer Noire: chronologie et typologie*, in M. Bonifat, J.-C. Trégli, LRCW2. *Late Roman Coarse Wares, Cooking Wares and Amphorae in the Mediterranean World. Archaeology and Archaeometry*, vol. II, BAR Int. Series 1662, Archaeopress, Oxford: 803-815.
- Schachner A. 2010, *Hattusa Kayalardan Şekillendirilmiş Bir Şehir*, in 1. Çorum Kazı ve Araştırmalar Sempozyumu, Çorum: 111-136.
- Schirmer W. 1969, *Die bebauung am unteren Büyükkale-Nordwesthang in Boğazköy. Ergebnisse der untersuchungen der grabungscampagnen 1960-1963* (Wissenschaftliche Veröffentlichung der Deutschen Orient-Gesellschaft 81, Boğazköy-Hattuša: Ergebnisse der Ausgrabungen VI), Gebr. Mann Verlag, Berlin.
- Schmidt E.F. 1931, *Anatolia through the Ages. Discoveries at the Alishar Mound 1927-9* (OIC 11), The University of Chicago Press, Chicago.
- Schmidt E.F. 1932, *The Alishar Huyuk. Seasons of 1928 and 1929. Part I* (OIP XIX), The University of Chicago Press, Chicago.
- Schmidt E.F. 1933, *The Alishar Huyuk. Seasons of 1928 and 1929. Part II* (OIP XX), The University of Chicago Press, Chicago.
- Schoop U.-D. 2003, *Pottery Tradition of the Late Hittite Empire: Problems of Definition*, in B. Fischer, H. Genz É.J., K. Köroğlu (eds.), *Identifying Changes: the Transition from Bronze to Iron Ages in Anatolia and its Neighbouring Regions, Proceedings of the International Workshop, Istanbul, November 8-9, 2002*, Türk Eskiçağ Bilimleri Enstitüsü, Istanbul: 215-238.
- Schoop U.-D. 2005a, *Early Chalcolithic in North-Central Anatolia: the Evidence from Boğazköy – Büyükkaya*, «TUBA-AR», *Türkiye Bilimler Akademisi Arkeoloji Dergisi*, 8: 15-37.
- Schoop U.-D. 2005b, *Das anatolische Chalkolithikum. Eine chronologische Untersuchung zur vorbronzezeitlichen Kultursequenz im nördlichen Zentralanatolien und den angrenzenden Gebieten*, Verlag BA Greiner, Remshalden.
- Schoop U.-D. 2009, *Indications of Structural Change in the Hittite Pottery Inventory at Boğazköy-Hattuša*, in F. Pecchioli Daddi, G. Torri, C. Corti (eds.), *Central-North Anatolia in the Hittite Period. New Perspectives in Light of Recent Researches (Acts of the International Conference held at the University of Florence, 7-9 February 2007)* (Studia Asiana 5), Herder, Roma: 145-167.
- Schoop U.-D. 2011a, *The Chalcolithic on the Plateau*, in S.R. Steadman, G. McMahon (eds.), *The Oxford Handbook of Ancient Anatolia: 10,000-323 b.c.e.*, Oxford University Press, New York: 150-173.
- Schoop U.-D. 2011b, *Hittite pottery: a summary*, in H. Genz, D.-P. Mielke (eds.), *Insights into hittite history and archaeology* (Colloquia Antiqua 2), Walpole, Peeters, Leuven, Paris: 241-274.
- Seidl U. 1972, *Gefäßmarken von Boğazköy* (Wissenschaftliche Veröffentlichung der Deutschen Orient-Gesellschaft 88, Boğazköy-Hattuša: Ergebnisse der Ausgrabungen VIII), Mann Verlag, Berlin Gebr.
- Shepard A.O. 1985 (first published 1956, 12th printing, 1985), *Ceramics for the Archaeologist*, Carnegie Institution of Washington, Washington DC.
- Steadman S.R. 2011, *The Early Bronze Age on the Plateau*, in S.R. Steadman, G. McMahon (eds.), *The Oxford Handbook of Ancient Anatolia*, Oxford University Press, Oxford: 230-259.
- Steadman S.R., McMahon G., Ross J.C., Cassis M., Geyer J.D., Arbuckle B., von Baeyer M. 2013, *The 2009 and 2012 Seasons of Excavations at Çadır Höyük on the Anatolian North Central Plateau*, «Anatolica», 39: 113-167.
- Steadman S.R., Ross J.C., McMahon G., Gorny R.L. 2008, *Excavations on the North Central Plateau: The Chalcolithic and Early Bronze Age Occupation at Çadır Höyük*, «Anatolian Studies», 58: 47-86.

- Strobel K., Gerber C. 2000, *Tavium (Büyüknefes, Provinz Yozgat). Ein regionales Zentrum Anatoliens. Bericht über den Stand der Forschungen nach den ersten drei Kampagnen (1997-1999)*, «Istanbuler Mitteilungen», 50: 215-265.
- Strobel K. 1997, Galatica I. Beiträge zur historischen Geographie und Geschichte Ostgalatiens, «Orbis terrarum. Internationale Zeitschrift für Historische Geographie der Alten Welt», 3: 131-153.
- Strobel K. 2009, The Galatians in the Roman Empire. Historical tradition and ethnic identity in Hellenistic and Roman Asia Minor, in T. Derks, N. Roymans (eds.), *Ethnic Constructs in Antiquity. The Role of Power and Tradition*, Amsterdam University Press, Amsterdam: 117-144.
- Summers F., Summers G.D. 1994, *A Report On The 1994 Season*, Kerkenes Website, homepage two, reports, <http://kerkenes.metu.edu.tr/kerk2/17downlds/reportPdf/1994krepeng.pdf>.
- Summers G. 2014, *East of the Halys: thoughts on settlement patterns and historical geography in the late 2nd millennium and first half of the first millennium B.C.*, in H. Bru, G. Labarre (eds.), *L'Anatolie des peuples, des cités et des cultures (IIe millénaire av. J.-C.-Ve siècle ap. J.-C.)*, vol. I, Presses Universitaires de Franche-Comté, Besançon: 41-51.
- Summers G.D. 1994, *Grey Ware and the Eastern Limits of Phrygia*, in A. Çilingiroglu, D.H. French (eds.), *Anatolian Iron Age 3. The Proceedings of the Third Anatolian Iron Ages Colloquium held at Van, 6-12 August 1990*, The British Institute of Archaeology at Ankara (Monograph no 16), Ankara: 241-252.
- Summers G.D. 2001, *Keykavus Kale and Associated Remains on the Kerkenes Dağ in Cappadocia, Central Turkey*, «Anatolia Antiqua», 9: 39-60.
- Summers G.D. 2002, *Concerning the identification, location and distribution of the Neolithic and Chalcolithic settlements*, in F. Gérard, L. Thyssen, *The Neolithic of Central Anatolia. Internal Developments and External Relations During the 9th- 6th Millennia cal BC. Proceedings of the CANeW Table Ronde, Istanbul 23-24 November 2001*, Ege Yayınları, Istanbul: 131-137.
- Summers M.E.F., Summers G.D., Ahmet K. 1995, *The Regional Survey at Kerkenes Dağ: an Interim Report on the Seasons of 1993 and 1994*, «Anatolian Studies», 45: 43-68.
- Taylor J. 2000, Cultural depositional processes and post-depositional problems', in R. Francovich, H. Patterson, G. Barker (eds.), *Extracting meaning from ploughsoil assemblages (The Archaeology of Mediterranean Landscapes 5)*, Oxbow Books, Alden press, Oxford: 16-26.
- Thyssen L. 1993, *New Insights in Balkan-Anatolian Connections in the Late Chalcolithic: Old Evidence from the Turkish Black Sea Littoral*, «Anatolian Studies», 43: 207-237.
- Vionis A.K., Poblome J., Waelkens M. 2009, *Ceramic Continuity in Medieval Sagalassos, sw Anatolia (ca. 650-1250 AD)*, in T. Vorderstrasse, J. Roodenberg (eds.), *Archaeology of the Countryside in Medieval Anatolia*, Nederlands Instituut Voor Het Nabije Oosten, Leiden: 191-213.
- Von der Osten H.H. 1929, *Explorations in Hittite Asia Minor 1927-28: Cap III, The season of 1928* (OIC 6), The University of Chicago Press, Chicago.
- Von der Osten H.H. 1930, *Explorations in Hittite Asia Minor 1929: Cap V, The season of 1928. Notes on Garstang's 'The Hittite Empire'* (OIC 8), The University of Chicago Press, Chicago.
- Von der Osten H.H. 1933, *Discoveries in Anatolia 1930-31* (OIC 14), The University of Chicago Press, Chicago.
- Von der Osten H.H. 1937a, *The Alishar Huyuk Seasons of 1930-32, Part I* (OIP XXVIII), The University of Chicago Press, Chicago.
- Von der Osten H.H. 1937b, *The Alishar Huyuk Seasons of 1930-32, Part II* (OIP XXIX), The University of Chicago Press, Chicago.
- Von der Osten H.H. 1937c, *The Alishar Huyuk Seasons of 1930-32, Part III* (OIP XXX), The University of Chicago Press, Chicago.
- Witte-Orr J. 2007, Bricks and Tiles from the Triangular Tower at Amorium,, in B. Bohlendorf-Arslan, A.O. Uysal, J. Witte-Orr, (eds.), *Late antique and Medieval pottery and tiles in Mediterranean archaeological contexts: Proceedings of the First International Symposium on Late Antique, Byzantine, Seljuk, and Ottoman pottery and tiles in archaeological contexts (Canakkale, 1-3 June 2005)*, (=BYZAS 7, Veröffentlichungen des Deutschen Archäologischen Instituts Istanbul), Ege Yayınları, Istanbul: 295-308.
- Zoroğlu L. 1977, *Yozgat Mercimektepe Sondajı*, «Türk Arkeoloj Dergisi», 24 (1): 195-212.

*General Charts of materials recovered on the site of Uşaklı Höyük*³⁵³

Chart 1: Materials from the survey on Uşaklı Höyük lower terrace.

| Survey Units | Diagnostic Sherds (n.*) | Generic Sherds (n.*) | Sherds - total (n.*) | Sherds - total (Kg**) | Common Ware (Kg**) | Storage Ware (Kg**) | Kitchen Ware (Kg**) | Tiles (Kg**) | Slags (Kg**) | Year | Activity |
|--------------|-------------------------|----------------------|----------------------|-----------------------|--------------------|---------------------|---------------------|--------------|--------------|------|----------|
| D9 | 29 | 267 | 296 | 8.14 | 7.26 | 0.78 | 0.10 | 0.15 | 0.06 | 2009 | Survey |
| D10 | 11 | 198 | 209 | 7.38 | 5.76 | 1.60 | 0.02 | 5.98 | 0.10 | 2009 | Survey |
| D14 | 27 | 177 | 204 | 8.05 | 6.09 | 1.50 | 0.46 | 2.28 | 0.02 | 2009 | Survey |
| D15 | 21 | 252 | 273 | 10.67 | 6.48 | 3.94 | 0.25 | 0.65 | 0.35 | 2009 | Survey |
| E16 | 30 | 298 | 328 | 13.30 | 9.30 | 3.98 | 0.02 | 8.51 | 2.73 | 2009 | Survey |
| F13 | 28 | 275 | 303 | 10.53 | 7.88 | 2.15 | 0.50 | 28.44 | 0.34 | 2009 | Survey |
| F14 | 25 | 298 | 323 | 9.58 | 7.37 | 1.92 | 0.29 | 13.52 | 0.14 | 2009 | Survey |
| F15 | 20 | 306 | 326 | 10.36 | 7.28 | 3.04 | 0.04 | 6.67 | 0.01 | 2009 | Survey |
| F16 | 39 | 220 | 259 | 9.86 | 7.16 | 2.66 | 0.04 | 17.52 | 0.15 | 2009 | Survey |
| F17 | 36 | 217 | 253 | 15.44 | 6.56 | 8.88 | | 16.50 | | 2009 | Survey |
| F18 | 23 | 216 | 239 | 7.30 | 5.90 | 1.40 | | 1.78 | 0.36 | 2009 | Survey |
| G13 | 34 | 315 | 349 | 10.74 | 8.84 | 1.68 | 0.22 | 5.46 | | 2009 | Survey |
| G14 | 50 | 304 | 354 | 8.93 | 7.55 | 1.38 | | 0.84 | 0.11 | 2009 | Survey |
| G15 | 70 | 375 | 445 | 13.37 | 11.56 | 1.61 | 0.20 | 1.30 | 0.21 | 2009 | Survey |
| G16 | 44 | 380 | 424 | 11.33 | 9.96 | 1.37 | | 1.29 | 0.11 | 2009 | Survey |
| G17 | 62 | 305 | 367 | 7.89 | 7.40 | 0.49 | | 3.30 | 0.10 | 2009 | Survey |
| G18 | 44 | 220 | 264 | 7.42 | 6.49 | 0.91 | 0.02 | 2.68 | 0.52 | 2009 | Survey |
| H13 | 75 | 330 | 405 | 14.19 | 12.89 | 1.30 | | 0.48 | | 2009 | Survey |
| H14 | 64 | 549 | 613 | 13.96 | 13.06 | 0.88 | 0.02 | 1.04 | | 2009 | Survey |
| H15 | 104 | 585 | 689 | 22.43 | 19.94 | 2.45 | 0.04 | 0.30 | | 2009 | Survey |
| H16 | 77 | 334 | 411 | 7.30 | 6.76 | 0.54 | | 0.20 | 0.05 | 2009 | Survey |
| H17 | 44 | 279 | 323 | 7.69 | 6.76 | 0.89 | 0.04 | | 0.14 | 2009 | Survey |
| H18 | 60 | 271 | 331 | 7.24 | 6.78 | 0.46 | | 11.48 | 1.46 | 2009 | Survey |
| L10 | 11 | 198 | 209 | 7.05 | 6.81 | | 0.24 | 2.88 | 0.01 | 2009 | Survey |
| L11 | 32 | 313 | 345 | 8.79 | 8.27 | 0.40 | 0.12 | | 0.31 | 2009 | Survey |
| L5 | 8 | 109 | 117 | 3.69 | 2.96 | 0.68 | 0.05 | 6.01 | 0.40 | 2009 | Survey |
| L6 | 3 | 128 | 131 | 2.55 | 2.36 | 0.16 | 0.04 | 4.10 | 0.01 | 2009 | Survey |
| L7 | 10 | 153 | 163 | 5.84 | 4.05 | 1.75 | 0.04 | 7.04 | 0.08 | 2009 | Survey |
| L8 | 23 | 162 | 185 | 6.37 | 5.47 | 0.88 | 0.02 | 1.57 | | 2009 | Survey |
| L9 | 32 | 265 | 297 | 12.60 | 8.11 | 4.08 | 0.41 | 1.73 | | 2009 | Survey |
| M11 | 25 | 291 | 316 | 8.64 | 7.34 | 1.25 | 0.05 | 0.32 | | 2009 | Survey |
| N11 | 16 | 173 | 189 | 5.30 | 4.87 | 0.30 | 0.13 | 0.03 | 0.04 | 2009 | Survey |
| K19 | 65 | 155 | 220 | 6.49 | 6.31 | | 0.18 | 0.30 | 6.82 | 2008 | Survey |
| J19 | 227 | | 227 | 6.97 | 4.83 | 2.10 | 0.04 | 2.90 | 3.95 | 2008 | Survey |
| I19 | 103 | 358 | 461 | 7.96 | 6.16 | 1.80 | | 1.13 | 6.40 | 2008 | Survey |
| H19 | 67 | 276 | 343 | 9.06 | 7.29 | 1.77 | | 12.01 | 2.06 | 2008 | Survey |
| G19 | 82 | 324 | 406 | 12.23 | 12.03 | 0.20 | | 15.56 | 2.82 | 2008 | Survey |
| F19 | 96 | 341 | 437 | 12.14 | 10.47 | 1.67 | | 0.86 | 0.18 | 2008 | Survey |
| F20 | 137 | 396 | 533 | 20.19 | 16.54 | 3.42 | 0.23 | 0.98 | 0.13 | 2008 | Survey |
| Outside Unit | 9 | | 9 | | | | | | | 2009 | Survey |
| Totals | 1963 | 10613 | 12576 | 378.93 | 308.86 | 66.27 | 3.78 | 187.79 | 30.16 | | |

³⁵³ For each survey unit the total amounts for the main categories of artifacts have been given: the number of diagnostic sherds, generic sherds and the sum of both categories; the weight in Kg of main functional ceramic classes and the total amount of recovered pottery; the amount in Kg of roof tiles and of combusted slags.

* : number

** : weight

Chart 2: Materials from the survey on Uşaklı Höyük lower terrace slopes.

| Survey Units | Diagnostic Sherds (n.*) | Generic Sherds (n.*) | Sherds - total (n.*) | Sherds - total (Kg**) | Common Ware (Kg**) | Storage Ware (Kg**) | Kitchen Ware (Kg**) | Tiles (Kg**) | Slags (Kg**) | Year | Activity |
|-----------------------|-------------------------|----------------------|----------------------|-----------------------|--------------------|---------------------|---------------------|--------------|--------------|------|---------------|
| <i>Lot -1; band 2</i> | 7 | 92 | 99 | 2.38 | 2.35 | | 0.03 | | 0.30 | 2009 | <i>Survey</i> |
| <i>Lot -1; band 3</i> | 7 | 89 | 96 | 3.33 | 2.98 | 0.30 | 0.05 | | 0.80 | 2009 | <i>Survey</i> |
| <i>Lot -1; band 4</i> | 18 | 168 | 186 | 5.01 | 4.88 | | 0.13 | 1.05 | | 2009 | <i>Survey</i> |
| <i>Lot -1; band 5</i> | 16 | 102 | 118 | 4.00 | 3.56 | 0.38 | 0.06 | | 0.01 | 2009 | <i>Survey</i> |
| <i>Lot -2; band 3</i> | 5 | 32 | 37 | 1.23 | 1.21 | | 0.02 | | 0.40 | 2009 | <i>Survey</i> |
| <i>Lot -2; band 4</i> | 8 | 69 | 77 | 3.38 | 3.08 | | 0.30 | | 0.02 | 2009 | <i>Survey</i> |
| <i>Lot -2; band 5</i> | 8 | 78 | 86 | 2.70 | 2.55 | 0.14 | 0.01 | | | 2009 | <i>Survey</i> |
| <i>Lot 1; band 1</i> | 21 | 59 | 80 | 3.22 | 2.22 | 1.00 | | 0.20 | | 2008 | <i>Survey</i> |
| <i>Lot 1; band 2</i> | 39 | 71 | 110 | 6.70 | 4.70 | 2.00 | | 2.10 | | 2008 | <i>Survey</i> |
| <i>Lot 1; band 3</i> | 43 | 129 | 172 | 9.20 | 5.60 | 3.60 | | 0.50 | | 2008 | <i>Survey</i> |
| <i>Lot 1; band 4</i> | 26 | 63 | 89 | 4.30 | 3.00 | 1.30 | | 1.85 | 1.50 | 2008 | <i>Survey</i> |
| <i>Lot 1; band 5</i> | 34 | 71 | 105 | 5.15 | 2.85 | 2.30 | | 0.85 | 0.32 | 2008 | <i>Survey</i> |
| <i>Lot 2; band 1</i> | 38 | 63 | 101 | 13.99 | 2.94 | 11.05 | | 0.50 | | 2008 | <i>Survey</i> |
| <i>Lot 2; band 2</i> | 90 | 267 | 357 | 14.58 | 11.58 | 3.00 | | | | 2008 | <i>Survey</i> |
| <i>Lot 2; band 3</i> | 157 | 498 | 655 | 22.03 | 16.43 | 5.60 | | | | 2008 | <i>Survey</i> |
| <i>Lot 2; band 4</i> | 116 | 201 | 317 | 10.18 | 8.40 | 1.78 | | 0.21 | | 2008 | <i>Survey</i> |
| <i>Lot 2; band 5</i> | 89 | 231 | 320 | 10.03 | 8.70 | 1.33 | | 0.24 | | 2008 | <i>Survey</i> |
| <i>Lot 3; band 1</i> | 29 | 66 | 95 | 4.12 | 2.22 | 1.90 | | 1.40 | 0.20 | 2008 | <i>Survey</i> |
| <i>Lot 3; band 2</i> | 74 | 293 | 367 | 12.38 | 9.51 | 2.70 | 0.17 | 0.62 | 0.18 | 2008 | <i>Survey</i> |
| <i>Lot 3; band 3</i> | 153 | 284 | 437 | 18.60 | 15.80 | 2.80 | | 0.30 | | 2008 | <i>Survey</i> |
| <i>Lot 3; band 4</i> | 91 | 203 | 294 | 10.17 | 8.44 | 1.60 | 0.13 | 0.36 | | 2008 | <i>Survey</i> |
| <i>Lot 3; band 5</i> | 29 | 66 | 95 | 3.38 | 2.96 | 0.42 | | 0.20 | | 2008 | <i>Survey</i> |
| <i>Lot 4; band 1</i> | 4 | 13 | 17 | 0.62 | 0.62 | | | | | 2008 | <i>Survey</i> |
| <i>Lot 4; band 2</i> | 104 | 229 | 333 | 13.86 | 11.54 | 2.12 | 0.20 | 0.74 | 0.18 | 2008 | <i>Survey</i> |
| <i>Lot 4; band 3</i> | 75 | 346 | 421 | 17.46 | 10.74 | 6.64 | 0.08 | 0.88 | | 2008 | <i>Survey</i> |
| <i>Lot 4; band 4</i> | 62 | 80 | 142 | 5.21 | 4.38 | 0.82 | 0.01 | 0.22 | | 2008 | <i>Survey</i> |
| <i>Lot 4; band 5</i> | 29 | 69 | 98 | 3.78 | 3.47 | 0.31 | | 0.50 | | 2008 | <i>Survey</i> |
| <i>Totals</i> | 1372 | 3932 | 5304 | 210.98 | 156.71 | 53.09 | 1.19 | 12.72 | 3.91 | | |

Chart 3: Materials from the survey on Uşaklı Höyük upper slopes.

| Survey Units | Diagnostic Sherds (n.*) | Generic Sherds (n.*) | Sherds - total (n.*) | Sherds - total (Kg**) | Common Ware (Kg**) | Storage Ware (Kg**) | Kitchen Ware (Kg**) | Tiles (Kg**) | Slags (Kg**) | Year | Activity |
|----------------------|-------------------------|----------------------|----------------------|-----------------------|--------------------|---------------------|---------------------|--------------|--------------|------|---------------|
| <i>Lot 5; band 1</i> | 1 | 17 | 18 | 0.50 | 0.40 | | 0.10 | | | 2010 | <i>Survey</i> |
| <i>Lot 5; band 2</i> | 6 | 27 | 33 | 0.83 | 0.83 | | | 0.23 | 0.02 | 2010 | <i>Survey</i> |
| <i>Lot 5; band 3</i> | 9 | 45 | 54 | 1.65 | 1.50 | 0.10 | 0.05 | | | 2010 | <i>Survey</i> |
| <i>Lot 5; band 4</i> | 2 | 20 | 22 | 0.64 | 0.60 | | 0.04 | | | 2010 | <i>Survey</i> |
| <i>Lot 5; band 5</i> | 12 | 30 | 42 | 2.05 | 1.40 | 0.65 | | | | 2010 | <i>Survey</i> |
| <i>Lot 5; band 6</i> | 1 | 24 | 25 | 0.72 | 0.72 | | | | 0.60 | 2010 | <i>Survey</i> |
| <i>Lot 5; band 7</i> | 2 | 14 | 16 | 0.76 | 0.56 | 0.20 | | | 0.75 | 2010 | <i>Survey</i> |
| <i>Lot 6; band 1</i> | 4 | 26 | 30 | 0.42 | 0.40 | | 0.02 | | | 2010 | <i>Survey</i> |
| <i>Lot 6; band 2</i> | 3 | 42 | 45 | 0.57 | 0.57 | | | | 0.02 | 2010 | <i>Survey</i> |
| <i>Lot 6; band 3</i> | 5 | 44 | 49 | 0.88 | 0.88 | | | | | 2010 | <i>Survey</i> |
| <i>Lot 6; band 4</i> | 4 | 15 | 19 | 0.29 | 0.29 | | | | 0.01 | 2010 | <i>Survey</i> |
| <i>Lot 6; band 5</i> | 5 | 12 | 17 | 0.78 | 0.78 | | | | | 2010 | <i>Survey</i> |
| <i>Lot 6; band 6</i> | 7 | 31 | 38 | 1.42 | 1.02 | 0.25 | 0.15 | | 0.75 | 2010 | <i>Survey</i> |
| <i>Lot 6; band 7</i> | 6 | 27 | 33 | 2.29 | 1.03 | 1.20 | 0.06 | | | 2010 | <i>Survey</i> |
| <i>Lot 7; band 1</i> | 0 | 38 | 38 | 0.37 | 0.37 | | | | 0.02 | 2010 | <i>Survey</i> |
| <i>Lot 7; band 2</i> | 8 | 37 | 45 | 0.52 | 0.52 | | | | | 2010 | <i>Survey</i> |
| <i>Lot 7; band 3</i> | 8 | 36 | 44 | 0.71 | 0.65 | | 0.06 | | | 2010 | <i>Survey</i> |
| <i>Lot 7; band 4</i> | 6 | 33 | 39 | 0.97 | 0.55 | 0.36 | 0.06 | | | 2010 | <i>Survey</i> |
| <i>Lot 7; band 5</i> | 5 | 28 | 33 | 0.75 | 0.55 | | 0.20 | | | 2010 | <i>Survey</i> |
| <i>Lot 7; band 6</i> | 22 | 62 | 84 | 2.34 | 1.80 | 0.46 | 0.08 | | 0.04 | 2010 | <i>Survey</i> |
| <i>Lot 7; band 7</i> | 17 | 76 | 93 | 3.29 | 2.31 | 0.90 | 0.08 | | 2.20 | 2010 | <i>Survey</i> |
| <i>Lot 7; band 8</i> | 5 | 34 | 39 | 1.81 | 1.26 | 0.50 | 0.05 | | | 2010 | <i>Survey</i> |
| <i>Lot 7; band 9</i> | 2 | 24 | 26 | 1.06 | 0.46 | 0.60 | | | 0.30 | 2010 | <i>Survey</i> |
| <i>Lot 8; band 1</i> | 5 | 37 | 42 | 0.75 | 0.65 | | 0.10 | | 0.02 | 2010 | <i>Survey</i> |
| <i>Lot 8; band 2</i> | 3 | 35 | 38 | 0.57 | 0.57 | | | | | 2010 | <i>Survey</i> |
| <i>Lot 8; band 3</i> | 3 | 34 | 37 | 0.58 | 0.58 | | | | | 2010 | <i>Survey</i> |
| <i>Lot 8; band 4</i> | 11 | 41 | 52 | 0.94 | 0.92 | | 0.02 | | | 2010 | <i>Survey</i> |
| <i>Lot 8; band 5</i> | 7 | 47 | 54 | 1.08 | 0.90 | | 0.18 | | | 2010 | <i>Survey</i> |
| <i>Lot 8; band 6</i> | 11 | 65 | 76 | 1.86 | 1.68 | | 0.18 | | | 2010 | <i>Survey</i> |
| <i>Lot 8; band 7</i> | 10 | 68 | 78 | 1.82 | 1.76 | | 0.06 | | 0.10 | 2010 | <i>Survey</i> |
| <i>Lot 8; band 8</i> | 10 | 42 | 52 | 1.76 | 1.22 | 0.50 | 0.04 | | | 2010 | <i>Survey</i> |
| <i>Lot 8; band 9</i> | 5 | 50 | 55 | 1.94 | 1.14 | 0.60 | 0.20 | 0.50 | 0.02 | 2010 | <i>Survey</i> |
| <i>Totals</i> | 205 | 1161 | 1366 | 36.91 | 28.87 | 6.32 | 1.73 | 0.73 | 4.85 | | |

Chart 4: Materials from the scraping and from small soundings on Uşaklı Höyük slopes.

| Survey Units | Diagnostic Sherds (n.*) | Generic Sherds (n.*) | Sherds - total (n.*) | Sherds - total (Kg**) | Common Ware (Kg**) | Storage Ware (Kg**) | Kitchen Ware (Kg**) | Tiles (Kg**) | Slags (Kg**) | Year | Activity |
|---------------------------|-------------------------|----------------------|----------------------|-----------------------|--------------------|---------------------|---------------------|--------------|--------------|------|-----------------|
| <i>Lot 9; band 1</i> | 31 | 81 | 112 | 2.50 | 2.19 | 0.17 | 0.13 | | | 2012 | <i>Scraping</i> |
| <i>Lot 9; band 2</i> | 73 | 128 | 201 | 4.20 | 3.81 | 0.12 | 0.28 | | 0.10 | 2012 | <i>Scraping</i> |
| <i>Lot 9; band 3</i> | 90 | 153 | 243 | 5.53 | 4.48 | 0.63 | 0.42 | | | 2012 | <i>Scraping</i> |
| <i>Lot 9; band 4</i> | 140 | 256 | 396 | 11.62 | 9.87 | 1.14 | 0.61 | | 0.06 | 2012 | <i>Scraping</i> |
| <i>Lot 9; band 5a</i> | 99 | 195 | 294 | 10.75 | 9.19 | 0.94 | 0.62 | 0.04 | 0.19 | 2012 | <i>Scraping</i> |
| <i>Lot 9; band 5b</i> | 92 | 178 | 270 | 8.74 | 7.91 | 0.50 | 0.33 | 0.32 | 0.32 | 2012 | <i>Scraping</i> |
| <i>Lot 9; band 6</i> | 149 | 369 | 518 | 17.48 | 13.88 | 2.95 | 0.66 | 0.78 | 1.09 | 2012 | <i>Scraping</i> |
| <i>Lot 9; band 7</i> | 124 | 277 | 401 | 16.07 | 13.24 | 2.36 | 0.47 | 0.67 | 1.06 | 2012 | <i>Scraping</i> |
| <i>Lot 9; band 8</i> | 170 | 308 | 478 | 16.48 | 13.83 | 2.17 | 0.48 | | 1.50 | 2012 | <i>Scraping</i> |
| <i>Lot 9; band 9</i> | 133 | 324 | 457 | 14.06 | 11.57 | 1.50 | 0.99 | | 5.50 | 2012 | <i>Scraping</i> |
| <i>Lot 11; band 3</i> | 60 | 106 | 166 | 4.08 | 3.53 | 0.14 | 0.42 | | 0.01 | 2012 | <i>Scraping</i> |
| <i>Lot 11; band 4</i> | 44 | 98 | 142 | 3.66 | 3.42 | | 0.24 | | 0.03 | 2012 | <i>Scraping</i> |
| <i>Lot 11; band 5</i> | 100 | 171 | 271 | 9.68 | 8.72 | 0.60 | 0.36 | | 0.34 | 2012 | <i>Scraping</i> |
| <i>Lot 11; band 6</i> | 76 | 105 | 181 | 7.50 | 6.70 | 0.58 | 0.23 | | 0.15 | 2012 | <i>Scraping</i> |
| <i>Lot 11; band 7</i> | 88 | 165 | 253 | 7.06 | 5.37 | 1.24 | 0.45 | 0.21 | 1.57 | 2012 | <i>Scraping</i> |
| <i>Lot 11; band 8</i> | 96 | 207 | 303 | 10.78 | 8.48 | 1.74 | 0.56 | | 1.24 | 2012 | <i>Scraping</i> |
| <i>Lot 11; band 9</i> | 121 | 206 | 327 | 12.28 | 8.72 | 3.01 | 0.55 | | 3.51 | 2012 | <i>Scraping</i> |
| <i>Acropolis Gates NW</i> | 40 | 50 | 90 | 3.01 | 2.80 | 0.07 | 0.14 | 2.07 | 0.06 | 2012 | <i>Sounding</i> |
| <i>Lot 10; band 9</i> | 55 | 149 | 204 | 5.96 | 4.98 | 0.68 | 0.31 | 0.23 | 0.02 | 2012 | <i>Sounding</i> |
| <i>Lot 12; band 1+2</i> | 107 | 200 | 307 | 7.15 | 6.00 | 0.57 | 0.59 | | 0.19 | 2012 | <i>Scraping</i> |
| <i>Lot 12; band 3</i> | 56 | 115 | 171 | 4.60 | 4.28 | | 0.33 | | 0.04 | 2012 | <i>Scraping</i> |
| <i>Lot 12; band 4</i> | 101 | 208 | 309 | 10.60 | 9.25 | 0.75 | 0.60 | | 0.63 | 2012 | <i>Scraping</i> |
| <i>Lot 12; band 5</i> | 84 | 144 | 228 | 10.62 | 10.07 | | 0.55 | 0.15 | 1.66 | 2012 | <i>Scraping</i> |
| <i>Lot 12; band 6</i> | 101 | 219 | 320 | 11.02 | 9.59 | 0.99 | 0.45 | | 2.16 | 2012 | <i>Scraping</i> |
| <i>Totals</i> | 2230 | 4412 | 6642 | 215.45 | 181.87 | 22.83 | 10.75 | 4.46 | 21.43 | | |

List of Diagrams

- Diagram 1: The range of morphological types in drab ware
 a: Code layout
 b: Bottom-up layout
- Diagram 2: The range of general morphological categories attested in red slip ware
- Diagram 3: Main morphological groups attested in red slip ware
- Diagram 4: The complete range of types attested in red slip ware
 a: types 1-2A
 b: types 2B-5
 c: types 6-Z
- Diagram 5: Occurrence of main morphological types
 a: Code layout
 b: Bottom-up layout
- Diagram 6: Occurrence of main morphological types and variants
- Diagram 7: Type 1-Plates. Occurrence of main variants
 a: Code layout
 b: Bottom-up layout
- Diagram 8: Type 1-Plates. Occurrence of main variants and sub-variants
 a: Code layout
 b: Bottom-up layout
- Diagram 9: Type 2-Bowls. Occurrence of main variants
 a: Code layout
 b: Bottom-up layout
- Diagram 10: Type 2-Bowls. Occurrence of main variants and sub-variants
 a: Code layout
 b: Bottom-up layout
- Diagram 11: Type 2-Bowls. Occurrence of main variants and sub-variants on the inventory of main shapes
 a: Code layout
 b: Bottom-up layout
- Diagram 12: Type 2-Bowls. Occurrence of main variants, sub-variants and lesser variants
 a-Section I: Code layout (types 2A-2A.21)
 a-Section II: Code layout (types 2A.22a-2C.x)
 b-Section I: Bottom-up layout (0-0.45%)
 b-Section II: Bottom-up layout (0.50-5.71%)
- Diagram 13: Type 3-Goblets and Small Jars. Occurrence of main variants
 a: Code layout
 b: Bottom-up layout
- Diagram 14: Type 5-Neckless Jars. Occurrence of main variants, sub-variants and lesser variants
 a: Code layout
 b: Bottom-up layout
- Diagram 15: Type 6-Necked Jars. Occurrence of main variants
 a: Code layout
 b: Bottom-up layout
- Diagram 16: Type 6-Necked Jars. Occurrence of main variants, sub-variants and lesser variants
 a: Code layout
 b: Bottom-up layout
- Diagram 17: Type 8-Large, Deep, Closed Containers. Occurrence of main variants and sub-variants
 a: Code layout
 b: Bottom-up layout
- Diagram 18: Type Z-Undetermined, necked vessels. Occurrence of main variants, sub-variants and lesser variants
 a: Code layout
 b: Bottom-up layout
- Diagram 19: Type 20-Beaks and spouts. Occurrence of main variants and sub-variants
 a: Code layout

b: Bottom-up layout

Diagram 20: Type B-Morphology of bases. Occurrence of main variants

a: Code layout

b: Bottom-up layout

Diagram 21: Type H-Morphology of handles and lugs. Occurrence of main variants

a: Code layout

b: Bottom-up layout

List of Schemes

Scheme 1: Typology of vessel profiles

Scheme 2: Typology of neck profiles

Scheme 3: Typology of rim profiles

List of Charts

Chart 1: Materials from the survey on Uşaklı Höyük lower terrace

Chart 2: Materials from the survey on Uşaklı Höyük lower terrace slopes

Chart 3: Materials from the survey on Uşaklı Höyük upper slopes

Chart 4: Materials from the scraping and from small soundings on Uşaklı Höyük slopes

*Catalogue of Plates**Plate 15*

| Plate | UKn. | Ware | Type | T. | Figure | Other Plates |
|-------|------------------|------|--------|----|--------|--------------|
| 15.1 | 08.1695 | C | Bsh | H | 35.678 | |
| 15.1 | 09.1212 | C | Bsh | H | 35.677 | 28 |
| 15.1 | 09.801 | C | Bsh | H | 35.685 | 28 |
| 15.1 | 08.539 | C | Bsh | H | | |
| 15.1 | 09.54 | C | Bsh | H | | |
| 15.1 | 09.55 | C | Bsh | H | | |
| 15.1 | 08.1133 | C | Bsh | H | 35.681 | 28 |
| 15.1 | 08.382 | C | 2B.4a | H | 35.683 | |
| 15.1 | 08.2203 | C | Bsh | H | 35.680 | |
| 15.1 | 08.1376 | Pt | Bsh | H | | |
| 15.1 | 10.101 | Pt | Bsh | H | | 15.2 |
| 15.1 | 10.156 | C | 2 | H | 35.684 | 15.2 |
| 15.1 | 12.1268 | Pt | 6 | H | | |
| 15.2 | 10.109 | P | 2B.5a | H | 35.652 | |
| 15.2 | 10.101 | Pt | Bsh | H | | 15.1 |
| 15.2 | 10.192 | Rs | Bsh | H | | |
| 15.2 | 10.46 | Rs | 2B.4a | H | 35.654 | |
| 15.2 | 10.156 | C | 2 | H | 35.684 | 15.1 |
| 15.2 | 10.35 | Rs | 6A | H | | |
| 15.3 | 12.489 | C | Bsh | H | | |
| 15.3 | 12.492 | C | Bsh | H | | |
| 15.3 | 12.1264 | Pt | ZA.4 | H | | |
| 15.4 | 12.617 | C | Bsh | H | 35.686 | |
| 15.4 | 12.663 | Rs | 2C | H | 35.658 | |
| 15.4 | 08.846 | Rs | 2B.4 | H | 35.655 | |
| 15.5 | 08.1237/8 | Rs | 2B.4b | H | 11.266 | 28 |
| 15.5 | <i>not numb.</i> | P | | H | | |
| 15.5 | <i>not numb.</i> | P | | H | | |
| 15.5 | 09.790 | Rs | 2A | H | 35.643 | |
| 15.5 | 09.1208 | P | 2C.x | H | 35.660 | |
| 15.5 | 09.1169 | P | 2A.15b | H | 35.649 | |
| 15.5 | 09.247 | P | 2C.x | H | 35.661 | |
| 15.5 | 09.690 | P | 6B.1 | H | | |
| 15.5 | 09.892 | Rs | 6A | H | 35.667 | |
| 15.5 | 08.1108 | Rs | 6A | H | | |
| 15.5 | 08.1886 | Rs | 2A.15b | H | | |
| 15.5 | 08.1670 | P | ZA.4 | H | | |
| 15.5 | 08.1796 | Rs | W | H | | |
| 15.6 | 08.2210 | P | Bsh | H | 34.641 | |

| | | | | | | |
|-------|---------|----|--------|-----|--------|--|
| 15.7 | 12.1140 | Rs | 2B.3 | H | 35-653 | |
| 15.8 | 12.107 | Rs | 2A | H | 35.647 | |
| 15.8 | 12.105 | P | 5A | H | | |
| 15.8 | 12.1092 | Rs | 2B.2b | H | | |
| 15.8 | 12.106 | Rs | 5A | H | | |
| 15.8 | 12.112 | Rs | 5A | H | | |
| 15.8 | 12.135 | Rs | 6C.8 | H | | |
| 15.9 | 08.1519 | P | 1I | H | 35.642 | |
| 15.9 | 08.1931 | Rs | 5A.1 | H/W | 17.365 | |
| 15.9 | 08.883 | Rs | 2A.15b | H | 35.650 | |
| 15.9 | 08.1128 | Rs | 6A.1b | H | 35.672 | |
| 15.9 | 08.2195 | Rs | 2A.15b | H | 35.651 | |
| 15.9 | 08.564 | P | B1 | H | 35.676 | |
| 15.9 | 08.1231 | Rs | 6C.6a | H | 35.674 | |
| 15.10 | 09.1020 | P | 2C.x | H | 35.659 | |

Plate 16

| Plate | UKn. | Ware | Type | T. | Figure | Other Plates |
|-------|---------|------|-------|----|--------|--------------|
| 16.1 | 08.2109 | Rs | 2B.4b | W | 11.271 | 28 |
| 16.1 | 09.2 | Rs | 2C.2 | W | 15.341 | |
| 16.1 | 08.1590 | Rs | H7 | W | | |
| 16.1 | 10.218 | Rs | 2C.2 | W | 15.342 | |
| 16.1 | 08.2048 | Rs | H7 | W | | |
| 16.1 | 08.1626 | Rs | 2C.2 | W | 15.343 | |
| 16.1 | 08.1052 | Rs | 2B.4a | W | | |
| 16.1 | 08.1730 | Rs | 2B.4a | W | | |
| 16.1 | 08.1275 | Rs | 2A.16 | H | 6.122 | |
| 16.1 | 08.261 | Rs | 2B.4b | W | 11.272 | |
| 16.1 | 10.67 | Rs | 2, H7 | W | | |
| 16.1 | 09.314 | Rs | 2B.4a | W | 11.262 | |
| 16.1 | 08.741 | Rs | H4 | W | 32.591 | |
| 16.1 | 09.1 | Rs | 2B.9 | W | 12.301 | |
| 16.1 | 09.5 | Rs | H4 | W | | |
| 16.1 | 08.799 | Rs | 2B.4a | W | 11.259 | |
| 16.1 | 08.1714 | Rs | H4 | W | | |
| 16.1 | 08.2034 | Rs | H4 | W | | |
| 16.1 | 08.1123 | Rs | H4 | W | 32.593 | |
| 16.1 | 08.1628 | Rs | H1 | W | | |
| 16.1 | 08.1607 | Rs | B10 | W | | |

| | | | | | | |
|------|---------|----|--------|---|--------|----|
| 16.2 | 08.1155 | Rs | 2A.19a | W | | |
| 16.2 | 08.861 | Rs | 2A.18e | W | | |
| 16.2 | 08.1202 | Rs | 2B.2b | W | | |
| 16.2 | 08.1356 | Rs | 2B.2b | W | 11.246 | |
| 16.2 | 08.1523 | Rs | 2B.2b | W | | |
| 16.2 | 08.459 | Rs | 2B.5a | W | | |
| 16.2 | 08.1858 | Rs | 2A.1a | W | | |
| 16.2 | 08.1776 | Rs | 2B.2b | W | | |
| 16.2 | 08.760 | Rs | 2B.2c | W | | 28 |
| 16.3 | 08.1224 | Rs | 5A.8b | W | 18.388 | |
| 16.3 | 08.1442 | Rs | 5A.8b | W | | |
| 16.3 | 08.2105 | Rs | 5A.8b | W | 18.387 | |
| 16.3 | 08.1039 | Rs | 2B.15b | W | 13.318 | 28 |
| 16.4 | 08.841 | Rs | 2B | W | | |
| 16.4 | 08.1542 | Rs | 2B.2a | W | | |
| 16.4 | 08.1220 | Rs | 2B.2a | W | 10.235 | |
| 16.4 | 08.1392 | Rs | 2B.4b | W | 11.267 | |
| 16.4 | 08.1457 | Rs | 2B.4b | W | | |
| 16.5 | 09.1280 | Rs | H1 | W | 32.584 | |
| 16.6 | 08.1560 | Rs | H1 | W | | |
| 16.6 | 08.409 | Rs | H8 | W | | |
| 16.6 | 08.1673 | Rs | B10 | W | | |

Plate 17

| Plate | UKn. | Ware | Type | T. | Figure | Other Plates |
|-------|---------|------|--------|-----|--------|--------------|
| 17.1 | 08.1289 | Rs | 2C.2 | W | 15.340 | |
| 17.1 | 08.314 | Rs | 2B.7c | W | | |
| 17.1 | 08.1915 | Rs | 3A.1 | W | | |
| 17.1 | 08.1078 | Rs | 2B.7c | W | | |
| 17.1 | 08.2026 | Rs | 3A.2 | W | 16.357 | |
| 17.1 | 08.1263 | Rs | 3A.1 | W | 16.346 | |
| 17.1 | 08.1682 | Rs | 2C.2 | W | | |
| 17.1 | 08.946 | Rs | 3A.1 | W | | |
| 17.2 | 08.1087 | Rs | 2B.1 | W | | |
| 17.2 | 08.287 | Os | 2A.6 | W | | 29 |
| 17.2 | 08.878 | Rs | 3 | W | | |
| 17.2 | 08.375 | Rs | 2B.1 | W | | |
| 17.2 | 08.1252 | Rs | 2 | W | | |
| 17.2 | 08.368 | Rs | 2B.11b | W | 12.305 | |
| 17.2 | 08.2123 | Rs | 2A.1a | W | | |
| 17.2 | 08.1020 | Rs | 2B.11a | W | | 28 |
| 17.2 | 08.2013 | Rs | 2B.15b | W | | |
| 17.3 | 09.1277 | Rs | 6D | W H | 20.459 | |

| | | | | | | |
|------|---------|----|--------|---|--------|--|
| 17.4 | 09.3 | Rs | 20A.2 | W | 29.541 | |
| 17.5 | 09.1279 | Rs | 20C.5 | W | 29.551 | |
| 17.6 | 09.1274 | Rs | 2B.11a | W | 12.304 | |
| 17.7 | 08.1026 | Rs | 8B.2 | W | 24.484 | |
| 17.7 | 08.1113 | Rs | 8B.3 | W | 24.485 | |
| 17.7 | 09.1216 | Rs | 7A | W | | |
| 17.7 | 08.957 | Rs | 8B.3 | W | | |
| 17.7 | 08.1027 | Rs | 8B.3 | W | | |

Plate 18

| Plate | UKn. | Ware | Type | T. | Figure | Other Plates |
|-------|---------|------|--------|----|--------|--------------|
| 18.1 | 08.776 | D | 2A.2 | W | | |
| 18.1 | 08.802 | P | 2A.2 | W | 3.61 | |
| 18.1 | 08.1103 | P | 2A.2 | W | | |
| 18.1 | 08.303 | P | 2A.2 | W | | |
| 18.1 | 08.1280 | P | 2A.20d | W | | |
| 18.1 | 08.1019 | D | 2A.1a | W | 3.38 | 31 |
| 18.1 | 08.897 | D | 2A.2 | W | | |
| 18.2 | 08.1085 | D | 2A.17b | W | | 31 |
| 18.2 | 08.1096 | D | 2A.17a | W | 6.125 | |
| 18.3 | 08.748 | P | 2A.19b | W | | |
| 18.3 | 08.1177 | D | 2A.17b | W | | |
| 18.3 | 08.322 | P | 2A | W | | |
| 18.3 | 08.257 | P | 2A.9 | W | 4.86 | |
| 18.3 | 08.827 | D | 2A.1b | W | | |
| 18.4 | 08.764 | D | 2A.18a | W | 7.143 | |
| 18.4 | 08.1583 | D | 2A.18a | W | | |
| 18.4 | 08.1035 | D | 2A.7 | W | | |
| 18.4 | 08.164 | P | 1H.3 | W | | |
| 18.4 | 08.363 | D | 2A.18b | W | 7.145 | |
| 18.4 | 08.1217 | P | 2A.18a | W | | |
| 18.5 | 08.348 | D | 2A.9 | W | 4.84 | |
| 18.5 | 08.362a | D | 2A.10 | W | 5.87 | |
| 18.5 | 08.1762 | P | 2A.1b | W | | |
| 18.5 | 08.2049 | Ps | 2A.11c | W | | |
| 18.5 | 08.39 | P | 2A | W | | |
| 18.6 | 08.1197 | D | 2B.17 | W | | |
| 18.6 | 08.1565 | P | 2B.17 | W | | |
| 18.6 | 08.436 | P | 2B.18 | W | 14.334 | |
| 18.6 | 08.1269 | P | 2B.17 | W | 13.324 | |
| 18.6 | 08.2147 | P | 2B.16 | W | | |
| 18.6 | 08.414 | P | 2B.8 | W | 12.300 | |

Plate 19

| Plate | UKn. | Ware | Type | T. | Figure | Other Plates |
|-------|---------|------|------|----|--------|--------------|
| 19.1 | 09.279 | K | 1G | W | 2.22 | 19.3 |
| 19.1 | 08.49 | K | 1G | W | | 19.3 |
| 19.1 | 09.755 | K | 1B | W | 1.10 | |
| 19.1 | 09.382 | K | 1B | W | 1.9 | |
| 19.1 | 09.859 | K | 1F | W | 2.21 | |
| 19.1 | 09.106 | K | 1G | W | 2.23 | |
| 19.1 | 09.1242 | K | 1G | W | | 19.2, 33 |
| 19.1 | 09.1204 | K | 1G | W | | |
| 19.1 | 09.779 | P | 1F | W | | |
| 19.1 | 09.791 | K | 1G | W | | 19.2 |
| 19.1 | 09.318 | K | 1G | W | | 19.2 |
| 19.1 | 09.934 | K | 1D | W | | |
| 19.1 | 09.1091 | K | 1F | W | | |
| 19.1 | 09.1033 | K | 1G | W | | |
| 19.1 | 09.1207 | K | 1F | W | | |
| 19.2 | 09.791 | K | 1G | W | | 19.1 |
| 19.2 | 09.1242 | K | 1G | W | | 19.1, 33 |
| 19.2 | 09.318 | K | 1G | W | | 19.1 |
| 19.3 | 08.2000 | K | 1B | W | 1.8 | |
| 19.3 | 09.279 | K | 1G | W | 2.22 | 19.1 |
| 19.3 | 08.49 | K | 1G | W | | 19.1 |

Plate 20

| Plate | UKn. | Ware | Type | T. | Figure | Other Plates |
|-------|------------------|------|------|----|--------|--------------|
| 20.1 | 08.1243 | Rs | Bsh | W | 34.628 | |
| 20.1 | 08.1907 | Rs | Bsh | W | 34.627 | |
| 20.1 | 08.858 | Rs | Bsh | W | 34.632 | |
| 20.1 | 08.432 | Rs | Bsh | W | 34.634 | |
| 20.1 | 09.8 | Rs | Bsh | W | 34.633 | |
| 20.1 | 09.1256 | Rs | Bsh | W | 34.631 | |
| 20.1 | 08.1753 | Rs | H10 | W | 33.604 | |
| 20.2 | 12.804 | Rs | Bsh | W | 34.630 | |
| 20.3 | 09.305 | P | Bsh | W | 34.635 | |
| 20.3 | 09.586 | P | Bsh | W | | |
| 20.3 | 09.647 | P | H | W | | |
| 20.4 | <i>not numb.</i> | | | | | |
| 20.4 | <i>not numb.</i> | | | | | |
| 20.4 | <i>not numb.</i> | | | | | |
| 20.4 | 08.1912 | Rs | Bsh | W | | |

Plate 21

| Plate | UKn. | Ware | Type | T. | Figure | Other Plates |
|-------|----------|------|--------|----|--------|--------------|
| 21.1 | 08.1816 | K | 5A.8a | W | | 33 |
| 21.1 | 08.761 | K | 5A.6 | W | | |
| 21.1 | 08.378 | K | 5A.3 | W | | |
| 21.1 | 08.1579 | K | 5A.8a | W | 18.386 | |
| 21.1 | 08.618 | K | 5A.8a | W | 18.385 | |
| 21.1 | 08.1487 | K | 5A.3 | W | | |
| 21.1 | 08.768 | K | 5A.1 | W | | |
| 21.1 | 08.685 | K | 5A.3 | W | | |
| 21.2 | 08.1831 | K | 5A.1 | W | | |
| 21.2 | 08.915 | P | 2C.1b | W | 15.337 | |
| 21.2 | 08.307 | K | 5A.3 | W | | |
| 21.2 | 08.789 | K | 5A.3 | W | | |
| 21.2 | 09.1096 | P | 6A.1a | W | | |
| 21.3 | 09.1272 | G | 2A.30 | W | 10.220 | |
| 21.3 | 09.65 | G | 2A.2 | W | | |
| 21.4 | 09.491 | Gr | 2A | W | | |
| 21.4 | 09.868 | Gr | 2B.5b | W | | |
| 21.4 | 09.776 | G | ZA.10 | W | 28.530 | |
| 21.4 | 09.378 | P | 8A.2 | W | 22.471 | |
| 21.4 | 09.51 | Gp | B5 | W | | |
| 21.4 | 09.921 | K | B1 | W | | |
| 21.4 | 09.574 | Gr | Bsh | W | | |
| 21.4 | 09.1138 | G | Bsh | W | | 32 |
| 21.4 | 09.616 | Gr | ZA.4 | W | | 32 |
| 21.4 | 09.1032 | Gr | H3 | H | | |
| 21.5 | 12.1513 | G | Bsh | W | 34.637 | |
| 21.5 | 12.1163 | G | 6B; H8 | H | | |
| 21.6 | 12.254 | G | 6C.7 | W | 20.450 | |
| 21.6 | 12.200 | G | 2A.19c | W | 8.164 | |
| 21.6 | 12.1164 | G | B5 | W | | |
| 21.7 | 09.373 | P | 5A.5 | W | | |
| 21.7 | 09.1078 | P | 2A.16 | W | | |
| 21.7 | 09.988 | P | 2A.28 | W | 9.210 | |
| 21.7 | 09.665 | P | 5A.5 | W | | |
| 21.7 | 09.1101 | Bb | 2A.23 | W | 9.196 | |
| 21.7 | 09.684 | P | 1H.2 | W | | |
| 21.7 | 09.958 | Ps | 6C.2 | W | 20.432 | |
| 21.7 | K09.850B | P | B1 | W | | |

Plate 22

| Plate | UKn. | Ware | Type | T. | Figure | Other Plates |
|-------|---------|------|-------|----|--------|--------------|
| 22.1 | 09.1726 | P | 20C.4 | W | | |
| 22.1 | 09.1221 | P | 20C.4 | H | 29.549 | |
| 22.1 | 09.1264 | P | 20C.4 | W | | |
| 22.1 | 09.1269 | P | 20C.1 | W | | |
| 22.2 | 09.1010 | P | 2B.18 | W | 14.331 | |
| 22.2 | 09.975 | P | 7A | W | 21.462 | |
| 22.3 | 09.895 | P | B1a | W | | |
| 22.3 | 09.998 | P | B6a | W | | |
| 22.4 | 09.878 | Cg | 6B.4 | W | 19.416 | |
| 22.4 | 09.226 | Br | 6B.4 | W | 19.419 | |
| 22.4 | 09.241 | P | 6B.4 | W | 19.420 | |
| 22.4 | 09.389 | P | 6A.1a | W | 19.400 | |
| 22.4 | 09.17 | P | 5A.5 | W | 17.377 | |
| 22.5 | 09.4 | Ys | 8B.1 | W | 23.479 | |
| 22.6 | 09.985 | Ps | 8B.1 | W | 23.476 | |
| 22.6 | 09.979 | P | 8B.1 | W | 23.478 | |
| 22.6 | 09.898 | P | 8B.4 | W | 25.491 | |

Plate 23

| Plate | UKn. | Ware | Type | T. | Figure | Other Plates |
|-------|---------|------|-------|----|--------|--------------|
| 23.1 | 09.781 | Pt | Bsh | W | | |
| 23.1 | 09.320 | Pt | Bsh | W | | |
| 23.1 | 09.727 | Pt | Bsh | W | | |
| 23.1 | 09.485 | Pt | Bsh | W | | |
| 23.1 | 09.995 | Pt | ZA.10 | W | | |
| 23.1 | 09.796 | Pt | 6C.5 | W | 20.444 | |
| 23.1 | 09.620 | Pt | Bsh | W | | |
| 23.1 | 09.1109 | Pt | Bsh | W | | |
| 23.1 | 09.750 | Pt | Bsh | W | | |
| 23.1 | 09.537 | Pt | Bsh | W | | |
| 23.1 | 09.789 | Pt | 2B.5a | W | 12.275 | 23.3, 30 |
| 23.1 | 09.1104 | Pt | Bsh | W | | |
| 23.2 | 09.528 | Pt | 2A.30 | W | 10.219 | 25.1 |
| 23.2 | 09.390 | Pt | 2A.30 | W | | 25.1 |
| 23.3 | 09.789 | Pt | 2B.5a | W | 12.275 | 23.1, 30 |
| 23.4 | 09.677 | Pt | Bsh | W | | 24.3, 30 |
| 23.5 | 12.1131 | Pt | 9 | W | 29.552 | |
| 23.5 | 12.1132 | Pt | Bsh | W | | |
| 23.5 | 08.1704 | Pt | Bsh | W | 34.619 | |
| 23.6 | 09.309 | Pt | ZA.8 | W | 27.516 | |

| | | | | | | |
|------|--------|----|---------|---|--------|--|
| 23.6 | 09.621 | Pt | ZA.4 | W | | |
| 23.6 | 08.990 | Pt | H3 | W | | |
| 23.6 | 10.224 | Pt | Bsh | W | 34.612 | |
| 23.6 | 10.225 | Pt | Ha8 | W | | |
| 23.6 | 09.799 | Pt | Bsh | W | | |
| 23.6 | 10.28 | Pt | Bsh | W | | |
| 23.6 | 08.641 | Pt | Bsh | W | | |
| 23.7 | 09.774 | Ys | Bsh, H1 | W | | |
| 23.7 | 09.780 | Ys | H10 | W | | |
| 23.7 | 09.253 | Ys | H10 | W | | |
| 23.7 | 09.427 | Ys | H8 | W | | |
| 23.7 | 09.747 | Ys | Bsh | W | | |
| 23.7 | 09.718 | Ys | B7 | W | 31.580 | |
| 23.7 | 09.797 | Ys | 8A.3 | W | 22.472 | |

Plate 24

| Plate | UKn. | Ware | Type | T. | Figure | Other Plates |
|-------|---------|------|-------|----|--------|--------------|
| 24.1 | 10.45 | Pt | Bsh | W | | |
| 24.1 | 09.640 | Pt | W | W | | |
| 24.1 | 09.899 | Pt | W | W | 30.558 | |
| 24.1 | 09.336 | Pt | Bsh | W | | 30 |
| 24.1 | 10.27 | Pt | Bsh | W | | |
| 24.1 | 09.81 | Pt | Bsh | W | 34.626 | |
| 24.1 | 08.585 | Pt | Bsh | W | | |
| 24.1 | 08.362b | Pt | Bsh | W | | |
| 24.1 | 09.1186 | Pt | W | W | | |
| 24.2 | 09.1019 | Pt | 6A.1a | W | | |
| 24.2 | 09.441 | Pt | H1 | W | | |
| 24.2 | 09.702 | Pt | Bsh | W | | |
| 24.3 | 09.677 | Pt | Bsh | W | | 23.4, 30 |
| 24.3 | 09.9 | Pt | 6C.5 | W | | |
| 24.3 | 10.113 | Pt | Bsh | W | | |
| 24.3 | 09.976 | Pt | Bsh | W | | |
| 24.3 | 09.598 | Pt | H15 | W | 33.609 | 30 |
| 24.4 | 12.177 | Pt | Bsh | W | 34.622 | |
| 24.4 | 12.178 | Pt | Bsh | W | 34.623 | |
| 24.4 | 12.494 | Pt | Bsh | W | 34.625 | |
| 24.5 | 10.203 | Pt | Bsh | W | | |
| 24.5 | 09.312 | Pt | Bsh | W | | |
| 24.5 | 10.155 | Pt | Bsh | W | | |
| 24.5 | 09.654 | Pt | Bsh | W | | |
| 24.5 | 09.76 | Pt | Bsh | W | | |
| 24.5 | 09.639 | Pt | Bsh | W | | |

| | | | | | |
|------|---------|----|-------|---|--------|
| 24.5 | 10.40 | Pt | Bsh | W | |
| 24.5 | 10.39 | Pt | Bsh | W | |
| 24.5 | 10.1 | Pt | Bsh | W | |
| 24.6 | 12.773 | Pt | Bsh | W | |
| 24.6 | 12.496 | Pt | Bsh | W | |
| 24.6 | 12.317 | Pt | Bsh | W | |
| 24.6 | 12.1343 | Pt | Bsh | W | |
| 24.6 | 12.218 | Pt | 2B.5b | W | |
| 24.6 | 12.1133 | Pt | Bsh | W | |
| 24.6 | 12.1137 | Pt | Bsh | W | |
| 24.6 | 12.627 | Pt | Bsh | W | |
| 24.7 | 09.158 | Pt | ZA.9 | W | 27.525 |
| 24.7 | 09.181 | Pt | ZA.8 | W | 27.523 |
| 24.7 | 09.1246 | Pt | ZA.10 | W | 28.531 |
| 24.7 | 08.2219 | Pt | Bsh | W | |
| 24.7 | 09.1160 | Pt | Bsh | W | |
| 24.7 | 08.2226 | Pt | Bsh | W | |
| 24.7 | 09.549 | Pt | Bsh | W | 34.624 |

Plate 25

| Plate | UKn. | Ware | Type | T. | Figure | Other Plates |
|-------|------------|------|--------|----|--------|--------------|
| 25.1 | 09.1105 | Pt | ZA.10 | W | 28.533 | |
| 25.1 | 09.772+783 | Pt | ZA.8 | W | | |
| 25.1 | 09.1133 | Pt | ZA.8 | W | | |
| 25.1 | 09.570 | Pt | ZA.10 | W | | |
| 25.1 | 08.680 | Pt | ZA.10 | W | 28.527 | |
| 25.1 | 09.773 | Pt | ZA.8 | W | 27.515 | |
| 25.1 | 09.1110 | Pt | 6A.1a | W | | |
| 25.1 | 10.53 | Pt | Bsh | W | 34.613 | |
| 25.1 | 09.269 | Pt | 2A | W | | |
| 25.1 | 09.655 | Pt | ZA.4 | W | | |
| 25.1 | 09.368 | Pt | 2A.1b | W | 3.47 | |
| 25.1 | 09.180 | Pt | Bsh | W | | |
| 25.1 | 09.1089 | Pt | W | W | | |
| 25.1 | 09.1001 | Pt | 6C.9 | W | | |
| 25.1 | 08.2033 | Pt | Bsh | W | | |
| 25.1 | 09.516 | Pt | Bsh | W | | |
| 25.1 | 09.528 | Pt | 2A.30 | W | 10.219 | 23.2 |
| 25.1 | 09.390 | Pt | 2A.30 | W | | 23.2 |
| 25.2 | 09.963 | Pt | 5A.2 | W | 17.369 | |
| 25.2 | 09.1073 | Pt | 2A.23 | W | | |
| 25.2 | 09.1214 | Pt | 2A.22c | W | 8.190 | |
| 25.2 | 09.1061 | Pt | 2A.16 | W | | |

| | | | | | |
|------|---------|----|--------|----|--------|
| 25.2 | 09.622 | Pt | Bsh | W | |
| 25.2 | 08.566 | Pt | 6A.1a | W | 19.399 |
| 25.2 | 09.798 | Pt | Bsh | W | |
| 25.2 | 09.893 | Pt | H | W | |
| 25.2 | 08.2164 | Pt | Bsh | W | |
| 25.2 | 09.1250 | Pt | Bsh | W | |
| 25.2 | 09.36 | Pt | Bsh | W | |
| 25.2 | 08.1017 | Pt | ZA.4 | W | |
| 25.2 | 09.143 | Pt | 2A.14c | W | 5.112 |
| 25.2 | 09.812 | Pt | W | W | |
| 25.2 | 09.1088 | Pt | H | W | |
| 25.3 | 12.1139 | Pt | H3 | W | |
| 25.3 | 08.2199 | Pt | Bsh | W | 34.617 |
| 25.4 | 09.324 | Pt | ZA.8 | W | 27.513 |
| 25.4 | 09.1054 | Pt | Bsh | W | |
| 25.4 | 09.967 | Pt | 2A.22a | W | 8.184 |
| 25.4 | 09.107 | Pt | 2A.22b | W | 8.187 |
| 25.4 | 09.904 | Pt | Bsh | W | |
| 25.4 | 09.641 | Pt | Bsh | W | |
| 25.4 | 09.116 | Pt | 6B | W | |
| 25.4 | 09.1100 | Pt | 2A | W | |
| 25.4 | 09.961 | Pt | 6B | W | |
| 25.4 | 09.962 | Pt | 6C.9 | HW | 20.458 |
| 25.5 | 12.409 | Pt | Bsh | W | |
| 25.5 | 12.408 | Pt | Bsh | W | |
| 25.6 | 09.800 | Pt | Bsh | W | |

Plate 26

| Plate | UKn. | Ware | Type | T. | Figure | Other Plates |
|-------|---------|------|-----------|----|--------|--------------|
| 26.1 | 09.1122 | Os | 2A.2 | W | | |
| 26.1 | 09.953 | Os | 2A.5 | W | 4.78 | |
| 26.1 | 09.974 | Os | 2B | W | | |
| 26.1 | 09.944 | Os | 2A.5 | W | 4.77 | |
| 26.1 | 09.1225 | Os? | W | W | | 29 |
| 26.1 | 09.370 | Os | 2A.6 | W | 4.79 | |
| 26.1 | 09.986 | Os | 2A | W | | |
| 26.2 | 08.1086 | Gw | 2B.1 | W | 10.223 | 31 |
| 26.2 | 08.1606 | Gw | 2B.1 | W | | 31 |
| 26.2 | 08.262 | Bb | 2A.29a | W | 10.212 | |
| 26.2 | 08.569 | Ys | ZB | W | 16.360 | 30 |
| 26.2 | 08.587 | Bb | B10, IJ.1 | W | 31.582 | 29 |
| 26.3 | 09.955 | P | Bsh | W | | |
| 26.3 | 09.952 | P | Bsh | W | | |

| | | | | | | |
|------|---------|----|--------|---|--------|----|
| 26.4 | 09.589 | Pt | Bsh | W | | 30 |
| 26.4 | 09.746 | Bb | B5 | W | | |
| 26.4 | 09.1024 | P | B5 | W | | 31 |
| 26.5 | 09.949 | Cg | 2A.11b | W | 5.94 | |
| 26.5 | 09.950 | P | 1I | W | 2.33 | |
| 26.5 | 09.982 | Cg | ZA.6a | W | 26.509 | |
| 26.5 | 09.802 | Cg | 2A.28 | W | 9.211 | |
| 26.5 | 09.882 | P | 2B.2a | W | | |
| 26.5 | 09.1199 | P | 2A.11c | W | 5.99 | |
| 26.5 | 09.925 | K | 6A.1a | W | 19.398 | |
| 26.5 | 09.184 | K | 5A.3 | W | 17.372 | |
| 26.5 | 09.1094 | P | 2A.11a | W | 5.90 | |
| 26.5 | 09.911 | D | 2A.11b | W | 5.93 | |
| 26.6 | 08.762 | Ys | Bsh | W | 34.639 | |
| 26.6 | 12.47 | Rb | 1J.1 | W | 2.34 | |
| 26.6 | 12.1562 | Rb | B5 | W | 31.573 | |
| 26.7 | 09.19 | Cg | 2B.6 | W | 12.286 | |
| 26.7 | 09.1056 | Cg | 2B.6 | W | 12.287 | |

Plate 27

| Plate | UKn. | Ware | Type | T. | Figure | Other Plates |
|-------|---------|------|--------|----|--------|--------------|
| 27.1 | 09.163 | Cg | H3 | W | 32.586 | 32 |
| 27.1 | 09.230 | Cg | H13 | W | 33.606 | 32 |
| 27.1 | 09.948 | Cg | H6 | W | 32.596 | |
| 27.1 | 09.155 | Cg | 2A | W | | |
| 27.1 | 09.515 | Cg | 6C.9 | W | 20.455 | |
| 27.1 | 09.894 | P | 2B.13 | W | 13.310 | |
| 27.1 | 09.1172 | Cg | 6B.7 | W | 20.429 | |
| 27.1 | 09.389 | P | W | W | 30.561 | |
| 27.1 | 09.287 | Cg | 2B.14 | W | 13.312 | |
| 27.1 | 09.945 | Cg | 8 | W | | |
| 27.1 | 08.2181 | Cg | 6C.5 | W | | |
| 27.1 | 09.213 | Cg | 2A.14a | W | | 31 |
| 27.2 | 09.410 | P | H6 | W | | |
| 27.2 | 09.555 | P | H2 | W | | |
| 27.3 | 09.329 | Cg | H6 | W | | 32 |
| 27.3 | 09.947 | Cg | H5b | W | 32.594 | 32 |
| 27.4 | 08.1503 | P | 6A.5 | W | 19.406 | |
| 27.5 | 12.1514 | P | Bsh | W | 34.636 | |
| 27.6 | 12.485 | Pt | Bsh | W | | |
| 27.7 | 09.1185 | Cg | H3 | W | 32.589 | |
| 27.7 | 09.1247 | Bb | W | W | 29.556 | |
| 27.8 | 12.356 | Rs | 3A.5 | W | 16.363 | |

Plate 28 (clos-ups of cross sections)

| Plate | UKn. | Ware | Type | T. | Figure | Other Plates |
|-------|---------|------|--------|----|--------|--------------|
| 28 | 09.1212 | C | Bsh | H | 35.677 | 15.1 |
| 28 | 08.1133 | C | Bsh | H | 35.681 | 15.1 |
| 28 | 09.801 | C | Bsh | H | 35.685 | 15.1 |
| 28 | 08.1237 | Rs | 2B.4b | H | 11.266 | 15.5 |
| 28 | 08.2137 | Rs | 2A.19a | W | 7.157 | |
| 28 | 08.2109 | Rs | 2B.4b | W | 11.271 | 16.1 |
| 28 | 08.534 | Rs | 2B.4b | W | | |
| 28 | 08.1558 | Rs | 2B.2c | W | 11.249 | |
| 28 | 08.760 | Rs | 2B.2c | W | | 16.2 |
| 28 | 08.1020 | Rs | 2B.11a | W | | 17.2 |
| 28 | 08.1039 | Rs | 2B.15b | W | 13.318 | 16.3 |

Plate 29 (clos-ups of cross sections)

| Plate | UKn. | Ware | Type | T. | Figure | Other Plates |
|-------|---------|------|------------|----|--------|--------------|
| 29 | 08.287 | Os | 2A.6 | W | | 17.2 |
| 29 | 08.1750 | Rs | 2B.1 | W | | |
| 29 | 09.1225 | Os? | W | W | | 26.1 |
| 29 | 09.43 | Rs | 6C.5 | W | | |
| 29 | 08.1747 | Rs | ZA.1 | W | | |
| 29 | 08.1638 | Rs | ZA.3b | W | 26.500 | |
| 29 | 08.237 | Rs | ZA.7 | W | 26.512 | |
| 29 | 09.276 | Rs | 6C.5 | W | | |
| 29 | 08.2030 | Rs | ZA.2c | W | 26.497 | |
| 29 | 08.665 | Bb | 2A.19c | W | 8.167 | |
| 29 | 08.2064 | Bb | 2A.20e | W | 8.181 | |
| 29 | 08.1851 | Bb | 2A.2 | W | 3.57 | |
| 29 | 08.587 | Bb | B10 + 1J.1 | W | 31.582 | 26.2 |

Plate 30 (clos-ups of cross sections)

| Plate | UKn. | Ware | Type | T. | Figure | Other Plates |
|-------|---------|------|-------|----|--------|--------------|
| 30 | 09.1233 | Ys | 2A.2 | W | 3.53 | |
| 30 | 09.297 | Ys | Bsh | W | | |
| 30 | 09.281 | Ys | H8 | W | | |
| 30 | 09.357 | Ys | 6B.1 | W | | |
| 30 | 08.569 | Ys | ZB | W | 16.360 | 26.2 |
| 30 | 09.277 | Pt | Bsh | W | | |
| 30 | 09.789 | Pt | 2B.5a | W | 12.275 | 23.1, 23.3 |
| 30 | 09.677 | Pt | Bsh | W | | 23.4, 24.3 |

| | | | | | | |
|----|--------|----|-----|---|--------|------|
| 30 | 09.336 | Pt | Bsh | W | | 24.1 |
| 30 | 09.598 | Pt | H15 | W | 33.609 | 24.3 |
| 30 | 09.589 | Pt | Bsh | W | | 26.4 |
| 30 | 09.587 | Pt | Bsh | W | | |

Plate 31 (clos-ups of cross sections)

| Plate | UKn. | Ware | Type | T. | Figure | Other Plates |
|-------|---------|------|--------|----|--------|--------------|
| 31 | 08.1086 | Gw | 2B.1 | W | 10.223 | 26.2 |
| 31 | 08.1606 | Gw | 2 | W | | 26.2 |
| 31 | 09.1024 | P | B5 | W | | 26.4 |
| 31 | 08.1019 | D | 2A.1a | W | 3.38 | 18.1 |
| 31 | 08.1085 | D | 2A.17b | W | | 18.2 |
| 31 | 08.271 | D | 2A.14a | W | | |
| 31 | 09.239 | P | 1H.3 | W | | |
| 31 | 09.209 | Cg | H6 | W | | |
| 31 | 09.66 | P | 2A.14a | W | | |
| 31 | 09.213 | Cg | 2A.14a | W | | 27.1 |
| 31 | 09.662 | P | 6B.1 | W | | |
| 31 | 09.206 | P | Bsh | W | | |
| 31 | 09.447 | P | B | W | | |

Plate 32 (clos-ups of cross sections)

| Plate | UKn. | Ware | Type | T. | Figure | Other Plates |
|-------|---------|------|------|----|--------|--------------|
| 32 | 09.329 | Cg | H6 | W | | 27.3 |
| 32 | 09.533 | Cg | H6 | W | | |
| 32 | 09.230 | Cg | H13 | W | 33.606 | 27.1 |
| 32 | 09.172 | Cg | H6 | W | 32.595 | |
| 32 | 09.163 | Cg | H3 | W | 32.586 | 27.1 |
| 32 | 09.947 | Cg | H5b | W | 32.594 | 27.3 |
| 32 | 09.409 | Cg | H6 | W | | |
| 32 | 09.1003 | Cg | H3 | W | | |
| 32 | 09.806 | G | Bsh | W | | |
| 32 | 09.762 | Gr | Bsh | W | | |
| 32 | 09.1138 | G | Bsh | W | | 21.4 |
| 32 | 09.616 | Gr | ZA.4 | W | | 21.4 |

Plate 33 (clos-ups of cross sections)

| Plate | UKn. | Ware | Type | T. | Figure | Other Plates |
|-------|---------|------|-------|----|--------|--------------|
| 33 | 08.2205 | K | 1D | W | 2.18 | |
| 33 | 08.362a | D | 2A.10 | W | 5.87 | 18.5 |

| | | | | | | |
|----|---------|----|-------|---|--|--------|
| 33 | 09.1242 | K | 1G | W | | 19.1 |
| 33 | 08.1816 | K | 5A.8a | W | | 21.1 |
| 33 | 08.1995 | K | 5A.9 | W | | 18.390 |
| 33 | 08.1 | K | 6B.3 | W | | |
| 33 | 09.273 | P | 6C.5 | W | | |
| 33 | 09.960 | Gl | B5 | W | | 31.576 |
| 33 | 12.30 | Gl | Bsh | W | | 12.30 |

Plate 39

| Plate | SS3n. | Ware | Type | T. | Figure |
|-------|---------|-------|---------|----|--------|
| 39 | 08.2 | P | 2A.2 | H | 37.694 |
| 39 | 08.3 | Rs | 2A.7 | H | 37.697 |
| 39 | 08.4 | P | 2A.5 | H | 37.696 |
| 39 | 08.28 | P | 2 | H | |
| 39 | 08.11 | P | 2C.x | H | 37.702 |
| 39 | 08.12 | P | 6B | H | 37.701 |
| 39 | 08.14 | P | Bsh | H | |
| 39 | 08.21 | Rs | 2A.5 | H | 37.700 |
| 39 | 08.41 | ? | Bsh | H | |
| 39 | 08.17 | Pt | Bsh | W | |
| 39 | 08.10 | G | 5A.10 | H | 37.703 |
| 39 | 08.8 | Black | 2 | H | |
| 39 | 08.5 | P | 1A.1 | H | 37.693 |
| 39 | 08.6 | Rs | 2A.5 | H | 37.695 |
| 39 | 08.16+9 | Rs | 2A.5 | H | 37.699 |
| 39 | 08.24 | G | 2 | H | |
| 39 | 08.25 | G | 2 | H | |
| 39 | 08.1 | P | Bsh | W | |
| 39 | 08.13 | Bb | Bsh | H | 37.704 |
| 39 | 08.18 | | andiron | | 37.705 |
| 39 | 08.23 | P | 2 | W | |
| 39 | 08.42 | Ys | 2A.29a | W | 37.707 |
| 39 | 08.22 | P | 2A.18a | W | 37.706 |
| 39 | 08.43 | P | B10 | W | |
| 39 | 08.19 | Pt | H10 | H | 37.708 |

Plate 40

| Plate | SS9n. | Ware | Type | T. | Figure | Other Plates |
|-------|--------|------|------|----|--------|--------------|
| 40.1 | 10.7 | Br | 6C.5 | W | 39.730 | |
| 40.1 | 10.6+9 | Br | 6C.5 | W | 39.731 | |
| 40.1 | 10.17 | P | 6C.5 | W | 39.723 | 40.1 |
| 40.1 | 10.10 | P | 6C.5 | W | 39.728 | |

| | | | | | | |
|-------|--------|------------|--------|---|--------|------|
| 40.1 | 10.8 | Br | 6C.5 | W | 39.725 | |
| 40.1 | 10.11 | Br | 6C.5 | W | 39.724 | |
| 40.1 | 10.15 | P | 6C.8 | W | 39.729 | 40.3 |
| 40.1 | 10.12 | Br | 6C.5 | W | 39.727 | |
| 40.2 | 10.41 | Br | Bsh | W | | |
| 40.2 | 10.45 | Br | Bsh | W | | |
| 40.2 | 10.44 | Br | Bsh | W | | |
| 40.2 | 10.42 | Br | Bsh | W | | |
| 40.2 | 10.47 | Br | Bsh | W | 40.738 | |
| 40.2 | 10.46 | Br | Bsh | W | | |
| 40.3 | 10.15 | P | 6C.8 | W | 39.729 | 40.1 |
| 40.3 | 10.17 | P | 6C.5 | W | 39.723 | 40.3 |
| 40.4 | 10.26 | Br | H? | W | | |
| 40.4 | 10.18 | Br | H12 | W | 39.735 | |
| 40.4 | 10.28 | Br | H | W | | |
| 40.4 | 10.32 | Br | H12 | W | 39.736 | |
| 40.4 | 10.33 | Br | H12 | W | 39.733 | |
| 40.4 | 10.29a | Br | H | W | | |
| 40.4 | 10.19 | P | H | W | | |
| 40.5 | 10.49 | P | Bsh | W | 40.739 | |
| 40.6 | 10.1 | White Slip | 2A.20e | W | 39.719 | |
| 40.7 | 10.4 | Bb | 2 | W | 39.718 | |
| 40.8 | 10.29b | P | H | W | | |
| 40.9 | 10.27 | P | H3 | W | 39.734 | |
| 40.10 | 10.48 | Pt | W | W | | |
| 40.11 | 10.50 | P | Bsh | W | 40.737 | |

Plate 41

| Plate | SSn. | Ware | Type | T. | Figure |
|-------|---------------|------------------|-------|----|---------|
| 41.1 | SS1w 10.219 | Rs | 2B.5b | W | |
| 41.1 | SS1w 10.217 | D | 2A.2 | W | |
| 41.1 | SS1w 10.220 | P | 2 | W | |
| 41.1 | SS1w 10.215b | D | 2A.1b | W | |
| 41.1 | SS1w 10.222 | P | B5 | W | |
| 41.1 | SS1w 10.221 | P | ZA.6a | W | |
| 41.2 | SS1WNW 10.223 | Ys | W | W | 30.559 |
| 41.3 | SS2 10.1 | P | 099 | W | |
| 41.3 | SS2 10.3 | P | 6 | W | |
| 41.3 | SS2 10.2 | P | H | W | |
| 41.4 | SS4 10.1 | P | B | W | |
| 41.5 | SS4 10 | <i>not numb.</i> | | | |
| 41.5 | SS4 10 | <i>not numb.</i> | | | |
| 41.5 | SS4 10 | <i>not numb.</i> | | | |
| 41.5 | SS4 10 | <i>not numb.</i> | | | |
| 41.5 | SS4 10 | <i>not numb.</i> | | | |
| 41.5 | SS4 10 | <i>not numb.</i> | | | |
| 41.6 | SS6 10.2 | P | ZA.8 | W | 38b.711 |
| 41.6 | SS6 10.1 | P | ZA.8 | W | 38b.712 |
| 41.6 | SS6 10.4 | P | H10 | W | 38b.713 |
| 41.6 | SS6 10.5 | Pt | W | W | |
| 41.6 | SS6 10.3 | P | H | W | |
| 41.7 | SS7 10.2 | P | 6 | W | 38c.714 |
| 41.7 | SS7 10.4 | P | ZA.9 | W | 38c.716 |
| 41.7 | SS7 10.3 | P | 6 | W | |
| 41.7 | SS7 10.1 | P | ZA.9 | W | 38c.715 |
| 41.7 | SS7 10.5 | P | H | W | |
| 41.7 | SS7 10.6 | P | B1 | W | |

Catalogue of Figures

Notes to figures and plates

The sherd profiles have been grouped according to techniques and form. No attempt has been made to divide the whole repertoire into different chronological partition. A decision taken for the difficulty to understand in the most of cases a sure date of the type. In the end some figures show our diagnostic types for the main periods.

The identification number of the sherd report a K (for Kuşaklı, name used during the first two seasons, before to modify it in Uşaklı, according to an old map of the land register of Sorgun and to avoid confusion with the site of Kuşaklı/Sarissa) + the last two numbers of the year in which it has been picked up (for example K08 is for the season 2008) and the progressive registration number for that year.

As for as small objects and other findings, the abbreviation of inventory objects UK *number*. *Es.number*, *UKnumber.E.number* and *Unumber.E.number* refer respectively to objects collected during the survey, the scraping or the excavations (UK is the abbreviation for Kuşaklı/Uşaklı, used in the first campaigns for the inventory).

Key to the pottery catalogue

Abbreviations used in the description of pottery:

n.: number of sherds as referred to the drawing in the figures

UKn.: inventory number in Uşaklı Höyük collection

SS1-9: inventory number in Survey Sites 1-9

Area: square of provenience referred to topographic grid and collection units

HM: high mound south-eastern slope

TS: terrace northern slope

Gen.: outside unit.

Arbitrary survey units on the slopes, that is lots (*L*) and bands (*B*), are specified in italic type¹; lower terrace units, which correspond to the regular squares of the grid, are in normal (roman) type²

Type: morphological description³

W/Cl: ware (W) and functional class (Cl)

Wares include⁴:

Bb: Brown Burnished Ware

Br: Pseudo Brittle Ware

C: 'Cappadocian' [Handmade, Geometric Painted Ware]

Cg: Coarse Grained Ware

D: Drab Ware

G: Grey Ware

Gl: Glazed Ware

Gp: Grey Ware, Painted

Gr: Grey Ware, Rough

Gw: Gold Wash Ware

K: Kitchen

¹ E.g., the label 'L9, B8' stands for 'Lot 9, Band 8'.

² As example, in the label 'G17, d3', 'G17' is the 20x20m square in the topographic grid, whereas 'd3' is the 5x5m square within the 20x20m square.

³ Refer to § 2.2.4, *Typology*.

⁴ Refer to § 2.2.3, *Wares*.

O: Orange Fine Ware
 Os: Orange Slip Ware
 P: Plain Ware
 Ps: Pink Slip Ware
 Pt: Painted Ware
 Rb: Reddish Brown Ware
 Rs: Red Slip Ware
 Ys: Yellow Slip Wares

Functional classes include⁵:

C: Common and table wares
 K: Kitchen wares
 S: Storage and long term preservation wares
 F: Fine and luxury wares

E: texture evaluation

FF: very fine
 F: fine
 MF: medium-fine
 M: medium
 MC: medium-coarse
 C: coarse

ST: surface treatment – type of coat and secondary treatment

Numbers in the first position indicate:

1: rough, no coat/treatment
 2: primary (no slip)
 3: self-slip
 4: slip/painting

Capital Letters in the second position indicate:

S: smoothed
 V: vitrified
 B: burnished
 P: polished

Small letters refers to the orientation of finishing traces as described by capital letters, and stand for:

o: horizontal
 v: vertical
 b: slanting
 i: irregular

Fa: fabric – main inclusion

V: vegetal
 M: mineral
 MV: mineral and vegetal

Colours: main colours visible in surfaces (out.: outside surface; in: inner side surface) and freshly broken sections (sect.: section). In case two or more colours are registered in the same field, they are separated by a comma. Abbreviations used are referred to the Munsell Soil Color Chart: w. = white; o whitish; b. = black; br. = brown o brownish; y. = yellow o yellowish; g. = gray o grayish; o. = olive; r. = red o reddish; pi. = pink o pinkish; gr. = greenish; bl. = bluish - d. = dark; du. = dusky; l. = light; p. = pale; s. = strong; v. = very; we. = weak.

Surface colours may include:

s: colour of the Surface
Ss: colour of the Self-Slip
S: colour of the Slip.
P: colour of the Painted decoration

⁵ Refer to § 2.2.1., *Function*.

Section colours may include:

O: fracture colour on the outer margin.

C: fracture colour on the core.

I: fracture colour on the inner margin.

T: forming technique

H: handmade

W: wheelmade

HW: handmade and finished on the wheel

Pl: Plates of reference.

Figures Legend – (see catalogue for details)





| | |
|---|---------------------------------------|
|  | painting patterns (black, brown, red) |
|  | red and orange slips |
|  | brown burnished |
|  | light slips (whitish and yellow) |

Figure 1 – Type 1

| n. | UKn. | Area | Type | W/ Cl | E | ST | Fa | Colour (out) | Colour (in) | Colour (sect.) | T | Pl. |
|----|---------|----------|------|----------|----|-----|----|------------------------|-----------------------------------|---|----|------|
| 1 | 12.639 | L9,B6 | 1A.1 | K/K | C | 2S | M | r.br. - 2.5 YR 5/3 | r.br. - 2.5 YR 5/3 | r.br. - 2.5 YR 5/3 | W | |
| 2 | 12.2045 | L12,B5 | 1A.1 | K/K | MC | 1 | MV | y.r. - 5 YR 5/6 | y.r. - 5 YR 5/6 | y.r. - 5 YR 5/6 | W | |
| 3 | 12.894 | L9,B8 | 1A.1 | K/K | MC | 1 | M | r.y. - 5 YR 6/6 | r.y. - 5 YR 6/6 | O: r.y. - 5 YR 6/6 C: g. - 5 Y 5/1 I: r.y. - 5 YR 6/6 | W | |
| 4 | 08.1904 | L4,B1 | 1A.2 | K/K | M | 3So | M | Ss: pi. - 2.5 YR 8/4 | Ss: pi. - 2.5 YR 8/4 | r. - 2.5 YR 5/6 | W | |
| 5 | 12.1712 | L10,B9 | 1A.3 | Bb/C | M | 3B | M | r.y. - 5 YR 6/6 | Ss: v.p.br. - 10 YR 8/3 | O: r.y. - 5 YR 6/6 I: br. - 10 YR 5/3 | HW | |
| 6 | 12.1998 | L12,B4 | 1A.3 | K/K | C | 1 | MV | br. - 7.5 YR 5/4 | r.y. - 5 YR 6/6 | O: br. - 7.5 YR 5/4 I: r.y. - 5 YR 6/6 | W | |
| 7 | 12.1670 | Acr.NW | 1A.3 | P/C | M | 2S | M | r.y. - 5 YR 6/8 | l.br. - 7.5 YR 6/4 | O: r.y. - 5 YR 6/8 C: l.r. - 2.5 YR 6/6 I: l.br. - 7.5 YR 6/4 | W | |
| 8 | 08.2000 | L4,B2 | 1B | K/K | C | 3B | M | d.r.g. - 2.5 YR 3/1 | y.br. - 10 YR 5/4 | O: d.r.g. - 2.5 YR 3/1 I: y.br. - 10 YR 5/4 | W | 19.3 |
| 9 | 09.382 | G17,d3 | 1B | K/K | C | 2S | M | we.r. - 10 R 5/4 | we.r. - 10 R 5/4 | O: y.r. - 5 YR 5/6 C: d.g. GLEY 1 N 4 I: y.r. - 5 YR 5/6 | W | 19.1 |
| 10 | 09.755 | H15,c3 | 1B | K/K | C | 2B | M | br. - 7.5 YR 4/2 | r.br. - 5 YR 5/4, y.r. - 5 YR 4/6 | O: br. - 7.5 YR 4/2 C: d.g. - 10 YR 4/1 I: y.r. - 5 YR 4/6 | W | 19.1 |
| 11 | 08.2202 | Gen. | 1B | K/K | M | 2 | M | Ss: r.br. - 2.5 YR 5/4 | Ss: r.br. - 2.5 YR 5/4 | d.r.br. - 5 YR 3/2 | W | |
| 12 | 12.1877 | L12,B3 | 1B | K/K | M | 1 | M | d.r. - 2.5 YR 3/6 | d.r. - 2.5 YR 3/6 | d.r. - 2.5 YR 3/6 | W | |
| 13 | 12.1843 | L12,B1/2 | 1B | K/K | M | 1 | M | r.br. - 2.5 YR 4/3 | r.br. - 2.5 YR 4/3 | r.br. - 2.5 YR 4/3 | W | |
| 14 | 08.2201 | TS | 1C | K/K | M | 2So | M | br. - 7.5 YR 5/2 | r.br. - 5 YR 5/3 | O: br. - 7.5 YR 5/2 I: r.br. - 5 YR 5/3 | W | |
| 15 | 08.430 | Gen | 1C | K/K | C | 3S | M | Ss: r. - 10 R 5/6 | Ss: r. - 10 R 5/6 | br. - 7.5 YR 5/2 | W | |

Figures

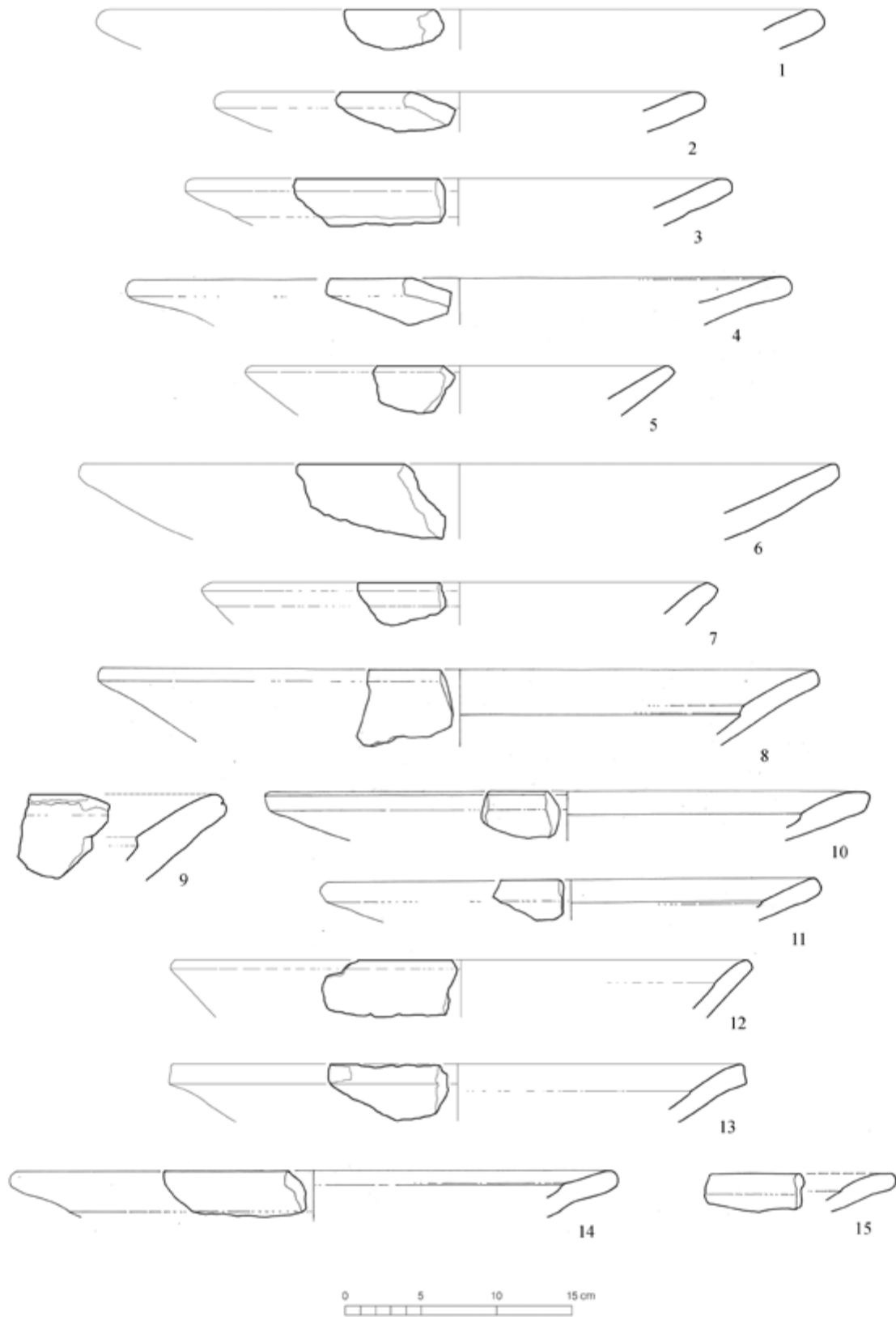


Fig. 1 – Pottery from Uşaklı Höyük.

Figure 2 – Type 1

| n. | UKn. | Area | Type | W/ Cl | E | ST | Fa | Colour (out.) | Colour (in.) | Colour (sect.) | T | Pl. |
|----|---------|--------|------|----------|----|------|----|------------------------------------|-----------------------------------|---|----|--------------|
| 16 | 09.934 | F13,d3 | 1C | K/K | M | 2S | M | l.br. - 7.5 YR 6/3 | l.br. - 7.5 YR 6/3 | l.br. - 7.5 YR 6/3 | W | 19.1 |
| 17 | 12.1944 | L12,B4 | 1C | P/C | M | 2S | M | r. - 2.5 YR 5/6 | r. - 2.5 YR 5/6 | O: r. - 2.5 YR 5/6 C: d.r.g. - 5 YR 4/2 I: r. - 2.5 YR 5/6 | W | |
| 18 | 08.2205 | TS | 1D | K/K | M | 3So | M | Ss: p.r. - 2.5 YR 6/2 | Ss: p.r. - 2.5 YR 6/2 | O: r.y. - 5 YR 6/6 C: d.g. GLEY 1 N 4 I: r.y. - 5 YR 6/6 | W | 33 |
| 19 | 08.1188 | L2,B3 | 1D | P/C | C | 2S | M | d.g. - 7.5 YR 4/1 | r.y. - 5 YR 6/6 | O: d.g. - 7.5 YR 4/1 C: l.br. - 7.5 YR 6/3 I: r.y. - 5 YR 6/6 | HW | |
| 20 | 12.192 | L9,B4 | 1E | P/C | MC | 3S | M | Ss: v.p.br. - 10 YR 8/4; | l.r. - 2.5 YR 6/8 | O: l.r. - 2.5 YR 6/8 C: pi.g. - 5 YR 6/2 I: l.r. - 2.5 YR 6/8 | W | |
| 21 | 09.859 | F14,d2 | 1F | K/K | M | 2Bb | M | r.br. - 2.5 YR 5/4 | l.r.br. - 5 YR 6/4 | O: r.br. - 2.5 YR 5/4 C: r. - 2.5 YR 4/6 I: l.r.br. - 5 YR 6/4 | W | 19.1 |
| 22 | 09.279 | H17,c2 | 1G | K/K | MC | 2So | M | r.br. - 5 YR 5/3, y.r. - 5 YR 5/6 | r.br. - 5 YR 5/3, y.r. - 5 YR 5/6 | O: r.br. - 5 YR 5/3 C: g. - 7.5 YR 5/1 I: r.br. - 5 YR 5/3 | W | 19.1 19.3 |
| 23 | 09.106 | H18,b4 | 1G | K/K | MC | 2So | M | v.p.br. - 10 YR 7/3 | l.r.br. - 2.5 YR 6/4 | O: v.p.br. - 10 YR 7/3 I: l.r.br. - 2.5 YR 6/4 | W | 19.1 |
| 24 | 08.49 | J19 | 1G | K/K | MF | 1 | M | l.r.br. - 2.5 YR 6/4 | l.r.br. - 2.5 YR 6/4 | l.r.br. - 2.5 YR 6/4 | W | 19.1 19.3 |
| 25 | 12.750 | L9,B7 | 1G | K/K | C | 1 | M | y.r. - 5 YR 5/6 | y.r. - 5 YR 5/6 | y.r. - 5 YR 5/6 | HW | |
| 26 | 12.1464 | L11,B8 | 1G | K/K | M | 1 | MV | r.y. - 5 YR 6/6 | r.y. - 5 YR 6/6 | r.y. - 5 YR 6/6 | W | |
| 27 | 12.397 | L9,B5A | 1G | K/K | MC | 1 | M | r. - 2.5 YR 5/8 | r. - 2.5 YR 5/8 | r. - 2.5 YR 5/8 | W | |
| 28 | 12.1038 | L9,B9 | 1G | K/K | MC | 1 | M | br. - 7.5 YR 5/4 | d.g. - 10 YR 4/1 | O: br. - 7.5 YR 5/4 I: d.g. - 10 YR 4/1 | W | |
| 29 | 08.1302 | L2,B4 | 1H.1 | K/K | M | 1 | M | r.br. - 5 YR 4/3 | r.br. - 5 YR 4/3 | r.br. - 5 YR 4/3 | W | |
| 30 | 12.1957 | L12,B4 | 1H.2 | D/C | M | 2S | M | br. - 7.5 YR 5/2 | g. - 7.5 YR 5/1 | O: br. - 7.5 YR 5/4 I: g. - 7.5 YR 5/1 | W | |
| 31 | 12.554 | L9,B6 | 1H.2 | P/C | C | 1 | M | r. - 10 R 5/6, d.g.br. - 2.5 Y 4/2 | o.y. - 5 Y 6/6 | O: d.g.br. - 2.5 Y 4/2 I: o.y. - 5 Y 6/6 | W | |
| 32 | 08.1132 | TS | 1H.3 | D/C | M | 2So | M | y.r. - 5 YR 5/6 | y.r. - 5 YR 5/6 | y.r. - 5 YR 5/6 | W | |
| 33 | 09.950 | L9,b1 | 1I | P/C | M | 2Bo | M | d.g. - 5 YR 4/1, r.g. - 5 YR 5/2 | r.br. - 5 YR 4/3 | O: r.g. - 5 YR 5/2 C: r.y. - 5 YR 6/6 I: r.br. - 5 YR 4/3 | W | 26.5 |
| 34 | 12.47 | L9,B2 | 1J.1 | Rb/F | MF | 4Bo | M | S: we.r. - 2.5 YR 4/2 | S: we.r. - 2.5 YR 4/2 | r.y. - 5 YR 6/6 | W | 26.6 |
| 35 | 12.1375 | L11,B7 | 1J.1 | Bb/C | M | 2Bo | M | l.br. - 7.5 YR 6/3 | l.br.g. - 10 YR 6/2 | O: l.br. - 7.5 YR 6/3 C: g.br. - 10 YR 5/2 I: l.br.g. - 10 YR 6/2 | W | |
| 36 | 12.506 | L9,B6 | 1J.2 | Rs/F | F | 4B-P | M | S: we.r. - 10 R 4/4 | l.r. - 2.5 YR 6/6 | l.r. - 2.5 YR 6/6 | W | |
| 37 | 12.117 | L9,B3 | 1J.2 | P/C | M | 2S | M | br. - 7.5 YR 5/4 | br. - 7.5 YR 5/4 | O: br. - 7.5 YR 5/4 C: v.d.g. - 7.5 YR 3/1 I: br. - 7.5 YR 5/4 | W | |

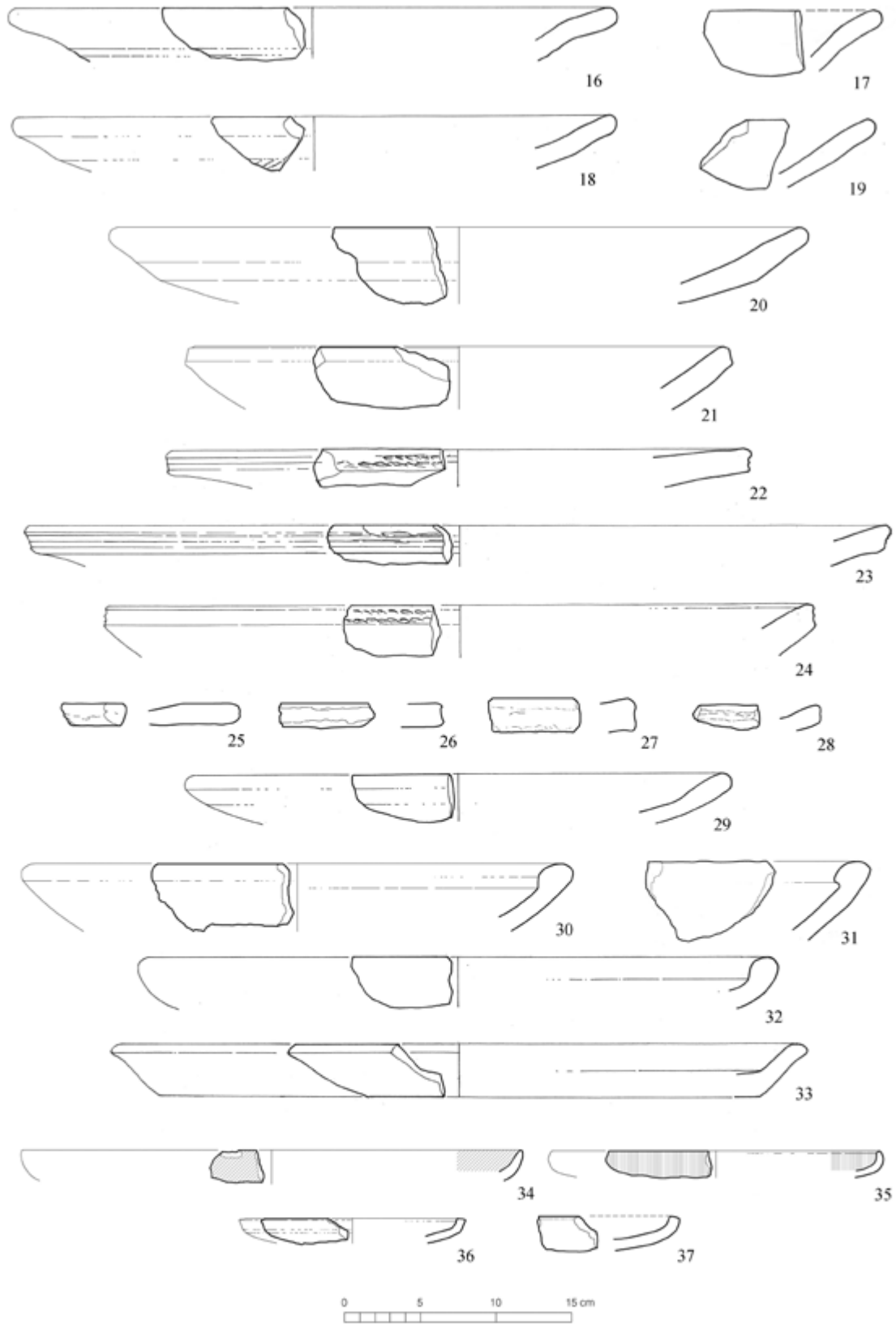


Fig. 2 – Pottery from Uşaklı Höyük.

Figure 3 – Type 2

| n. | UKn. | Area | Type | W/Cl | E | ST | Fa | Colour (out.) | Colour (in.) | Colour (sect.) | T | Pl. |
|----|--------------|----------|-------|------|----|------|----|------------------------|--|--|---|------------|
| 38 | 08.1019 | L2,B2 | 2A.1a | D/C | F | 2So | M | r.br. - 5 YR 5/3 | r.br. - 5 YR 5/3 | r.br. - 5 YR 5/3 | W | 18.1 31 |
| 39 | 12.539 | L9,B6 | 2A.1a | P/C | M | 2S | M | l.o.br. - 2.5 Y 5/4 | r.y. - 5 YR 6/8 | O: l.o.br. - 2.5 Y 5/4 I: r.y. - 5 YR 6/8 | W | |
| 40 | 12.1800 | L12,B1/2 | 2A.1a | P/C | M | 2S | M | r.y. - 7.5 YR 7/6 | r.y. - 7.5 YR 7/6 | r.y. - 7.5 YR 7/6 | W | |
| 41 | 12.1883 | L12,B3 | 2A.1a | Bb/C | M | 3Bo | M | Ss: r. - 2.5 YR 5/6 | r. - 2.5 YR 5/6 | r. - 2.5 YR 5/6 | W | |
| 42 | 08.423 | Gen. | 2A.1b | P/C | F | 2S | M | r.y. - 5 YR 6/6 | r.y. - 5 YR 6/6 | r.y. - 5 YR 6/6 | W | |
| 43 | 12.1718 | L12,B9 | 2A.1b | P/C | M | 2S | M | br. - 7.5 YR 5/4 | r.y. - 5 YR 6/6, br. - 7.5 YR 5/4 | O: br. - 7.5 YR 5/4 C: g. - 7.5 YR 5/1 I: br. - 7.5 YR 5/4 | W | |
| 44 | 12.820 | L9,B8 | 2A.1b | D/C | M | 1 | M | y.r. - 5 YR 5/6 | y.r. - 5 YR 5/6 | y.r. - 5 YR 5/6 | W | |
| 45 | 10.71 | L8,B4 | 2A.1b | Bb/C | MF | 3B | M | Ss: r.br. - 5 YR 5/4 | r.y. - 5 YR 6/6 | O: r.br. - 5 YR 5/4 I: r.y. - 5 YR 6/6 | W | |
| 46 | 09.884 | E16,a3 | 2A.1b | Rs/F | MF | 4B | M | S: r.br. - 2.5 YR 5/4 | S: y.r. - 5 YR 5/8 | O: r.br. - 2.5 YR 5/3 C: g. - 5 YR 5/1 I: y.r. - 5 YR 5/6 | W | |
| 47 | 09.368 | G17,c4 | 2A.1b | Pt/C | MF | 2B | M | l.br. - 7.5 YR 6/3 | P: d.r.g. - 2.5 YR 4/1 s: y.r. - 5 YR 5/8 | O: l.br. - 7.5 YR 6/3 C: br. - 7.5 YR 5/4 I: y.r. - 5 YR 5/8 | W | 25.1 |
| 48 | 12.4 | L9,B1 | 2A.2 | Rs/F | F | 4B | M | S: r. - 10 R 5/6 | S: r. - 10 R 5/8 | r. - 2.5 YR 5/6 | W | |
| 49 | 12.2111 | L12,B6 | 2A.2 | Rs/C | M | 4Bo | M | S: r. - 10 R 5/8 | S: r. - 10 R 5/8 | l.r.br. - 2.5 YR 6/3 | W | |
| 50 | 12.2133+2134 | L12,B6 | 2A.2 | D/C | M | 1 | M | l.r. - 2.5 YR 6/6 | l.r. - 2.5 YR 6/6 | l.r. - 2.5 YR 6/6 | W | |
| 51 | 12.2051 | L12,B5 | 2A.2 | Bb/F | MF | 4B | M | S: y.r. - 5 YR 5/6 | S: y.r. - 5 YR 5/6 | d.g. - 5 YR 4/1 | W | |
| 52 | 10.4 | L6,B1 | 2A.2 | Bb/F | F | 2B | M | r.br. - 5 YR 5/4 | r.br. - 2.5 YR 5/4 | O: r.br. - 2.5 YR 5/4 C: r. - 2.5 YR 5/6 I: r.br. - 2.5 YR 5/4 | W | |
| 53 | 09.1233 | D14,c1 | 2A.2 | Ys/F | F | 4P | M | S: p.y. - 2.5 Y 8/3 | S: p.y. - 2.5 Y 8/3 | r.y. - 5 YR 6/6 | W | 30 |
| 54 | 08.2220 | L2,B4 | 2A.2 | P/F | F | 2S | M | y.r. - 5 YR 5/6 | y.r. - 5 YR 5/6 | y.r. - 5 YR 5/6 | W | |
| 55 | 09.1213 | D14,a1 | 2A.2 | P/F | F | 2S | M | pi. - 7.5 YR 7/3 | pi. - 7.5 YR 7/3 | O: pi. - 7.5 YR 7/3 C: br. - 7.5 YR 5/4 I: pi. - 7.5 YR 7/3 | W | |
| 56 | 08.405 | F20,a2 | 2A.2 | P/F | F | 2S | M | r.y. - 5 YR 6/6 | r.y. - 5 YR 6/6 | r.y. - 5 YR 6/6 | W | |
| 57 | 08.1851 | L3,B4 | 2A.2 | Bb/F | F | 2B | M | r.br. - 5 YR 5/4 | r.br. - 5 YR 5/4 | O: r.br. - 5 YR 5/4 C: r.g. - 5 YR 5/2 I: r.br. - 5 YR 5/4 | W | 29 |
| 58 | 08.1303 | L2,B4 | 2A.2 | D/C | M | 1 | M | r.br. - 5 YR 5/3 | r.br. - 5 YR 5/3 | r.br. - 5 YR 5/3 | W | |
| 59 | 12.1197 | L11,B5 | 2A.2 | P/C | MF | 2S | M | br. - 7.5 YR 5/4 | br. - 7.5 YR 5/4 | br. - 7.5 YR 5/4 | W | |
| 60 | 12.1948 | L12,B4 | 2A.2 | P/C | M | 1 | M | r.y. - 7.5 YR 7/6 | r.y. - 7.5 YR 7/6 | O: r.y. - 7.5 YR 7/6 C: l.g. - 10 YR 7/1 I: r.y. - 7.5 YR 7/6 | W | |
| 61 | 08.802 | F19,a3 | 2A.2 | P/C | F | 2So | M | r.br. - 5 YR 5/4 | r.br. - 5 YR 5/4 | r.br. - 5 YR 5/4 | W | 18.1 |
| 62 | 08.415 | F20,a1 | 2A.2 | D/C | M | 2So | M | r. - 2.5 YR 5/8 | r. - 2.5 YR 5/8 | r. - 2.5 YR 5/8 | W | |
| 63 | 12.1674 | Acr.NW | 2A.3 | Bb/C | MF | 3B-P | M | Ss: r.y. - 5 YR 7/6 | r.y. - 5 YR 7/6 | r.y. - 5 YR 7/6 | W | |
| 64 | 12.1573 | L11,B9 | 2A.3 | P/C | M | 1 | M | r.y. - 5 YR 6/6 | r.y. - 5 YR 6/6 | O: r.y. - 5 YR 6/6 C: r. - 10 R 5/8 I: r.y. - 5 YR 6/6 | W | |
| 65 | 12.5 | L9,B1 | 2A.3 | Rs/C | M | 3Bo | M | Ss: r.br. - 2.5 YR 5/4 | Ss: r.br. - 2.5 YR 5/4 | br. - 7.5 YR 5/2 | W | |
| 66 | 12.664 | L9,B7 | 2A.3 | Rs/C | MC | 4Bo | MV | S: r. - 10 R 4/6 | S: r. - 10 R 4/6 | br.y. - 10 YR 6/6 | W | |
| 67 | 09.1273 | L2,B2 | 2A.3 | Rs/C | MF | 4Bo | M | S: r.br. - 5 YR 4/4 | l.br. - 7.5 YR 6/4 | O: br. - 7.5 YR 4/2 I: l.br. - 7.5 YR 6/4 | W | |
| 68 | 08.1687 | L3,B3 | 2A.4a | Rs/C | MF | 4 | M | S: r.y. - 5 YR 6/8 | S: r.y. - 5 YR 6/8 | r.y. - 5 YR 6/6 | W | |

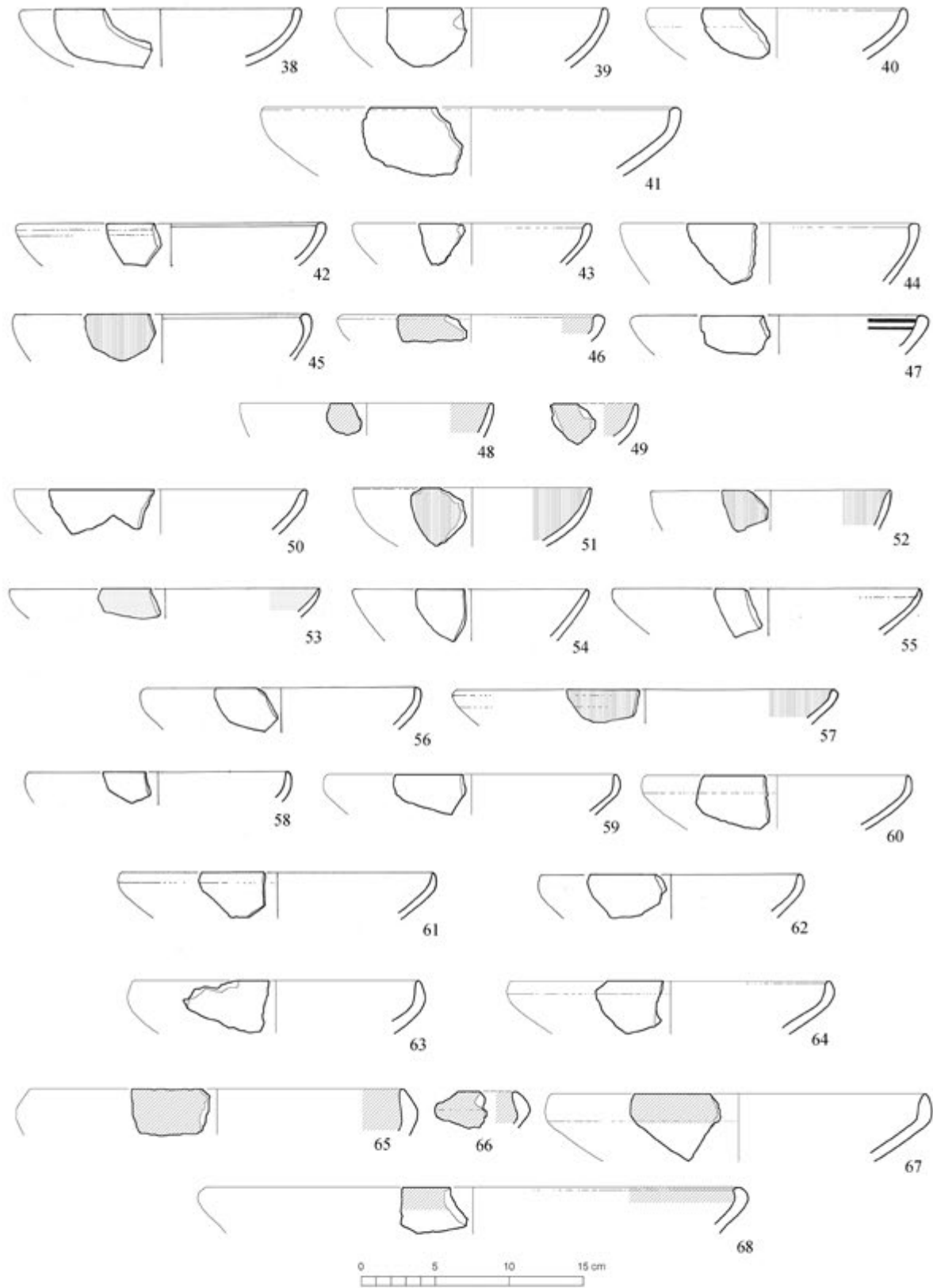


Fig. 3 – Pottery from Uşaklı Höyük.

Figure 4 – Type 2

| n. | UKn. | Area | Type | W/Cl | E | ST | Fa | Colour (out.) | Colour (in.) | Colour (sect.) | T | Pl. |
|----|---------|--------|-------|------|----|------|----|-------------------------|------------------------|---|----|------|
| 69 | 08.779 | F19,a4 | 2A.4a | D/C | F | 2S | M | r.y. - 5 YR 6/6 | r.y. - 5 YR 6/6 | O: r.y. - 5 YR 6/6 C: l.g. - 10 YR 7/1 I: r.y. - 5 YR 6/6 | W | |
| 70 | 12.210 | L9,B4 | 2A.4a | P/C | M | 2S | M | g. - 5 YR 5/1 | br. - 7.5 YR 5/2 | O: g. - 5 YR 5/1 C: r. - 2.5 YR 5/6 I: br. - 7.5 YR 5/2 | W | |
| 71 | 08.1498 | L3,B1 | 2A.4a | Rs/C | M | 4S | M | S: l.r. - 10 R 6/8 | S: l.r. - 10 R 6/8 | O: l.br. - 7.5 YR 6/4 C: d.g. GLEY 1 N 4 I: l.br. - 7.5 YR 6/4 | W | |
| 72 | 12.41 | L9,B2 | 2A.4b | G/C | M | 3Bo | M | Ss: g. - 5 YR 5/1 | g. - 5 YR 5/1 | g. - 5 YR 5/1 | W | |
| 73 | 09.870 | F15,b2 | 2A.4c | Rs/C | M | 4Bo | M | S: r. - 10 R 5/6 | S: r. - 10 R 5/6 | O: l.r.br. - 5 YR 6/4 C: g. - 5 YR 6/1 I: l.r.br. - 5 YR 6/4 | W | |
| 74 | 08.1213 | L2,B3 | 2A.4d | D/C | F | 2B | M | r.br. - 5 YR 5/4 | r.br. - 5 YR 5/4 | r.br. - 5 YR 5/4 | W | |
| 75 | 08.784 | F19,d3 | 2A.4d | D/C | F | 2S | M | l.r. - 2.5 YR 6/6 | l.r. - 2.5 YR 6/6 | O: l.r. - 2.5 YR 6/6 C: l.r. - 2.5 YR 6/8 I: l.r. - 2.5 YR 6/6 | W | |
| 76 | 08.792 | F19,c3 | 2A.4d | Rs/C | F | 4B | M | S: r. - 10 R 5/6 | S: r. - 10 R 5/6 | r.br. - 5 YR 5/4 | W | |
| 77 | 09.944 | L9,a1 | 2A.5 | Os/F | FF | 4Bo | M | S: l.r. - 2.5 YR 6/8 | S: l.r. - 2.5 YR 6/8 | r.y. - 5 YR 6/6 | W | 26.1 |
| 78 | 09.953 | L9,c4 | 2A.5 | Os/F | FF | 4Bo | M | S: r. - 10 R 5/6 | S: r. - 10 R 5/6 | r. - 10 R 4/6 | W | 26.1 |
| 79 | 09.370 | G17,c3 | 2A.6 | Os/F | FF | 4Bo | M | S: l.r. - 2.5 YR 6/8 | S: l.r. - 2.5 YR 6/8 | r.y. - 5 YR 6/6 | W | 26.1 |
| 80 | 09.900 | E16,c3 | 2A.6 | Os/F | FF | 4S+B | M | S: r.br. - 2.5 YR 4/3 | S: d.r. - 10 R 3/6 | O: r.y. - 5 YR 7/6 C: r.y. - 5 YR 6/6 I: r.y. - 5 YR 7/6 | W | |
| 81 | 09.731 | H15,b3 | 2A.7 | P/C | MF | 2S | M | v.p.br. - 10 YR 7/3 | v.p.br. - 10 YR 7/3 | O: v.p.br. - 10 YR 7/3 C: l.br. - 7.5 YR 6/4 I: v.p.br. - 10 YR 7/3 | H? | |
| 82 | 09.951 | L9,b1 | 2A.7 | P/C | M | 3S | M | Ss: l.br. - 7.5 YR 6/3 | Ss: l.br. - 7.5 YR 6/3 | O: r.y. - 5 YR 6/6 C: g. - 5 YR 6/ 6/6 I: r.y. - 5 YR 6/6 | W | |
| 83 | 09.46 | H16,b1 | 2A.8 | P/C | MF | 3S | M | Ss: v.p.br. - 10 YR 7/3 | l.br. - 7.5 YR 6/4 | O: l.br. - 7.5 YR 6/4 C: l.r. - 2.5 YR 6/6 I: l.br. - 7.5 YR 6/4 | W | |
| 84 | 08.348 | F20,b3 | 2A.9 | D/C | F | 2S | M | r. - 2.5 YR 5/6 | r. - 2.5 YR 5/6 | O: r. - 2.5 YR 5/6 C: g. GLEY 1 N 5 I: r. - 2.5 YR 5/6 | W | 18.5 |
| 85 | 08.1344 | L2,B4 | 2A.9 | Rs/C | M | 4 | M | S: we.r. - 10 R 5/4 | S: we.r. - 10 R 5/4 | y.r. - 5 YR 5/6 | W | |
| 86 | 08.257 | J19 | 2A.9 | P/C | M | 1 | M | y.r. - 5 YR 5/6 | y.r. - 5 YR 5/6 | y.r. - 5 YR 5/6 | W | 18.3 |

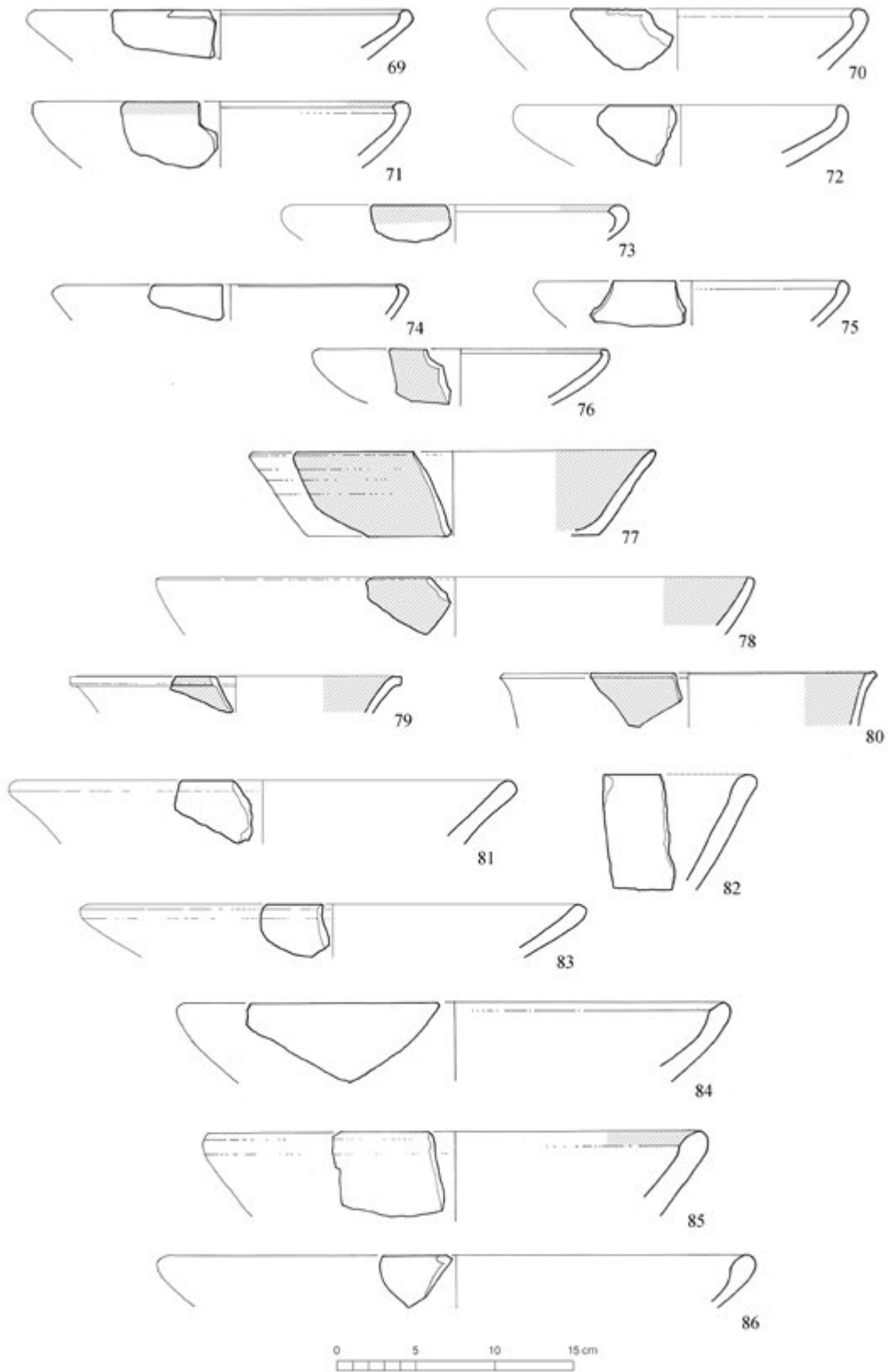


Fig. 4 – Pottery from Uşaklı Höyük.

Figure 5 – Type 2

| n. | UKn. | Area | Type | W/Cl | E | ST | Fa | Colour (out.) | Colour (in.) | Colour (sect.) | T | Pl. |
|-----|---------|--------|--------|-------|----|-----|----|---|--|--|---|------------|
| 87 | 08.362a | F20,b2 | 2A.10 | D/C | M | 2So | M | l.r. - 2.5 YR 6/6 | l.r. - 2.5 YR 6/6 | O: l.r. - 2.5 YR 6/6 C: g. GLEY 1 N 5 I: l.r. - 2.5 YR 6/6 | W | 18.5 33 |
| 88 | 12.92 | L9,B2 | 2A.10 | P/C | MC | 1 | M | y.r. - 5 YR 5/6 | y.r. - 5 YR 5/6 | O: y.r. - 5 YR 5/6 C: g. - 7.5 YR 5/1 I: y.r. - 5 YR 5/6 | W | |
| 89 | 12.2 | L9,B1 | 2A.10 | Gp/C | F | 2Bo | M | we.r. - 2.5 YR 4/2, l.br.g. - 10 YR 6/2 | l.br.g. - 10 YR 6/2, g. - 10 YR 6/1 | O: l.br.g. - 10 YR 6/2 C: g. - 10 YR 6/1 I: l.br.g. - 10 YR 6/2 | W | |
| 90 | 09.1094 | D9,c2 | 2A.11a | P/C | MF | 2S | M | l.r.br. - 2.5 YR 6/3 | l.r.br. - 2.5 YR 6/3 | O: l.r.br. - 2.5 YR 6/3 C: y.r. - 5 YR 5/6 I: l.r.br. - 2.5 YR 6/3 | W | 26.5 |
| 91 | 08.925 | L1,B3 | 2A.11a | D/C | M | 1 | M | l.r. - 2.5 YR 6/6 | l.r. - 2.5 YR 6/6 | O: l.r. - 2.5 YR 6/6 C: y.r. - 5 YR 5/6 I: l.r. - 2.5 YR 6/6 | W | |
| 92 | 12.197 | L9,B4 | 2A.11a | Bb/C | M | 3Bo | M | Ss: r.y. - 5 YR 6/6 | r.y. - 5 YR 6/6 | r.y. - 5 YR 6/6 | W | |
| 93 | 09.911 | F13,a3 | 2A.11b | D/C | M | 2S | M | pi. - 7.5 YR 7/4 | pi. - 7.5 YR 7/4 | O: pi. - 7.5 YR 7/4 C: y.r. - 5 YR 5/6 I: pi. - 7.5 YR 7/4 | W | 26.5 |
| 94 | 09.949 | L9,b1 | 2A.11b | Cg/C | M | 2S | M | r.g. - 5 YR 5/2, r.br. - 5 YR 5/4 | l.r.br. - 5 YR 6/3, r.br. - 5 YR 5/4 | O: r.br. - 5 YR 5/4 C: d.g. - 5 YR 4/1 I: r.br. - 5 YR 5/4 | W | 26.5 |
| 95 | 12.2041 | L12,B5 | 2A.11b | D/C | M | 1 | M | y.r. - 5 YR 4/6 | y.r. - 5 YR 4/6 | O: y.r. - 5 YR 4/6 C: g. - 5 YR 5/1 I: y.r. - 5 YR 4/6 | W | |
| 96 | 12.198 | L9,B4 | 2A.11b | P/C | M | 3 | M | Ss: r. - 2.5 YR 5/8 | r. - 2.5 YR 5/8 | r. - 2.5 YR 5/8 | W | |
| 97 | 12.2143 | L12,B6 | 2A.11c | D/C | M | 1 | M | l.r. - 2.5 YR 6/6 | l.r. - 2.5 YR 6/6 | O: l.r. - 2.5 YR 6/6 C: d.r.g. - 2.5 YR 3/1 I: l.r. - 2.5 YR 6/6 | W | |
| 98 | 12.2056 | L12,B5 | 2A.11c | P/C | M | 2S | M | y.r. - 5 YR 5/6 | y.r. - 5 YR 5/6 | y.r. - 5 YR 5/6 | W | |
| 99 | 09.1199 | D15,c2 | 2A.11c | P/C | M | 1 | M | r.br. - 5 YR 5/3, y.r. - 5 YR 5/6 | r.br. - 5 YR 5/3, y.r. - 5 YR 5/6 | O: y.r. - 5 YR 5/6 C: g. - 5 YR 5/1 I: y.r. - 5 YR 5/6 | W | 26.5 |
| 100 | 12.1937 | L12,B4 | 2A.11c | P-D/C | M | 2S | M | s.br. - 7.5 YR 4/6 | s.br. - 7.5 YR 4/6 | s.br. - 7.5 YR 4/6 | W | |
| 101 | 12.340 | L9,B5A | 2A.11d | P/C | M | 2B | M | r. - 2.5 YR 5/8 | r. - 2.5 YR 5/8 | O: r. - 2.5 YR 5/8 C: l.r. - 2.5 YR 6/8 I: r. - 2.5 YR 5/8 | W | |
| 102 | 12.556 | L9,B6 | 2A.11d | G/C | M | 3Bo | M | bl.g. GLEY 2 5/1 | bl.g. GLEY 2 5/1 | bl.g. GLEY 2 5/1 | W | |
| 103 | 08.2212 | Gen. | 2A.11e | P/C | F | 2S | M | l.r. - 2.5 YR 6/6 | l.r. - 2.5 YR 6/6 | l.r. - 2.5 YR 6/6 | W | |
| 104 | 08.697 | I19,c2 | 2A.11e | D/C | M | 1 | M | r.br. - 5 YR 5/4 | r.br. - 5 YR 5/4 | O: r.br. - 5 YR 5/4 C: v.d.g. - 5 YR 3/1 I: r.br. - 5 YR 5/4 | W | |
| 105 | 12.895 | L9,B8 | 2A.11e | K/K | C | 1 | M | d.g. - 10 YR 4/1 | d.g. - 10 YR 4/1 | d.g. - 10 YR 4/1 | W | |
| 106 | 09.912 | F13,a3 | 2A.12 | P/C | M | 2Bo | M | l.r.br. - 5 YR 6/4, r.y. - 5 YR 6/6 | l.r.br. - 5 YR 6/4, r.y. - 5 YR 6/6 | O: r.y. - 5 YR 6/6 C: g. - 5 YR 5/1 I: r.y. - 5 YR 6/6 | W | |
| 107 | 12.32 | L9,B2 | 2A.13 | P/C | M | 1 | M | r.y. - 5 YR 6/6 | r.y. - 5 YR 6/6 | O: r.y. - 5 YR 6/6 C: we.r. - 2.5 YR 4/2 I: r.y. - 5 YR 6/6 | W | |
| 108 | 09.732 | H15,b3 | 2A.14a | P/C | M | 2S | M | pi.g. - 7.5 YR 6/2, r.br. - 5 YR 5/4 | pi.g. - 7.5 YR 6/2, r.br. - 5 YR 5/4 | O: r.br. - 5 YR 5/4 C: br. - 7.5 YR 5/4 I: r.br. - 5 YR 5/4 | W | |
| 109 | 08.454 | G19,a2 | 2A.4a | D/C | M | 1 | M | l.r.br. - 5 YR 6/4 | l.r.br. - 5 YR 6/4 | l.r.br. - 5 YR 6/4 | W | |
| 110 | 12.36 | L9,B2 | 2A.14a | P/C | M | 3Bo | M | Ss: l.r. - 2.5 YR 6/8 | l.r. - 2.5 YR 6/8 | l.r. - 2.5 YR 6/8 | W | |
| 111 | 09.1085 | D9,b1 | 2A.14b | P/C | MF | 2S | M | l.r.br. - 2.5 YR 6/4, y.r. - 5 YR 5/6 | l.r.br. - 2.5 YR 6/4, y.r. - 5 YR 5/6 | y.r. - 5 YR 5/6 | W | |
| 112 | 09.143 | H18,d1 | 2A.14c | Pt/C | M | 4B | M | P: d.br. - 7.5 YR 3/2 S: l.r. - 2.5 YR 6/6 | S: l.r. - 2.5 YR 6/6 | r.y. - 7.5 YR 6/6 | W | 25.2 |
| 113 | 12.211 | L9,B4 | 2A.14c | Rs/C | M | 4Bo | M | S: r. - 10 R 4/6 | S: r. - 10 R 4/6 | d.r. - 10 R 3/6 | W | |

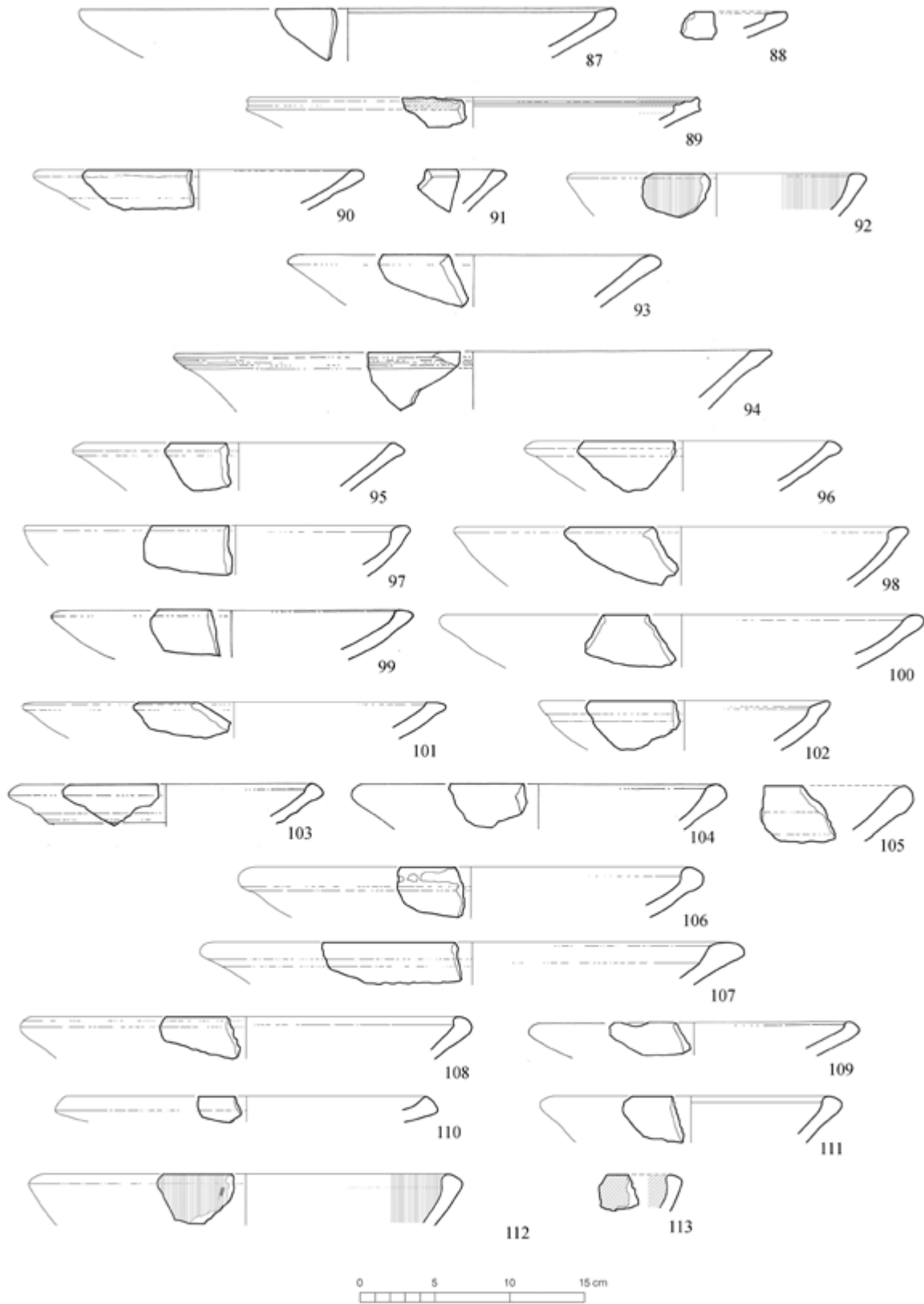


Fig. 5 – Pottery from Uşaklı Höyük.

Figure 6 – Type 2

| n. | UKn. | Area | Type | W/Cl | E | ST | Fa | Colour (out.) | Colour (in.) | Colour (sect.) | T | Pl. |
|-----|---------|--------|--------|-------|---|-----|----|------------------------------|--|---|----|------|
| 114 | 12.1882 | L12,B3 | 2A.14d | P/C | M | 1 | M | r.y. - 5 YR 6/8 | r.y. - 5 YR 6/8 | r.y. - 5 YR 6/8 | W | |
| 115 | 12.14 | L9,B1 | 2A.14e | G/C | M | 2Bo | M | d.g. - 10 YR 4/1 | d.g. - 10 YR 4/1 | d.g. - 10 YR 4/1 | W | |
| 116 | 08.1081 | L2,B2 | 2A.15a | P/C | F | 3 | M | Ss: r. - 2.5 YR 5/6 | r. - 2.5 YR 5/6 | r. - 2.5 YR 5/6 | W | |
| 117 | 12.195 | L9,B4 | 2A.16 | Bb/C | M | 3Bo | M | Ss: pi. - 7.5 YR 8/4 | Ss: pi. - 7.5 YR 8/4 | r.y. - 5 YR 7/8 | W | |
| 118 | 12.6 | L9,B1 | 2A.16 | Bb/C | M | 2Bo | M | y.r. - 5YR 5/6 | y.r. - 5YR 5/6 | y.r. - 5YR 5/6 | W | |
| 119 | 12.327 | L9,B5A | 2A,16 | Rs/C | M | 4S | M | S: we.r. - 10 R 4/3 | S: we.r. - 10 R 4/3 | y.br. - 10 YR 5/6 | W | |
| 120 | 12.1480 | L11,B8 | 2A,16 | Rs/C | M | 4B | V | S: y.r. - 5 YR 5/6 | S: y.r. - 5 YR 5/6 | y.r. - 5 YR 5/8 | W | |
| 121 | 12.2034 | L12,B5 | 2A,16 | Rs/C | M | 4S | V | S: we.r. - 10 R 4/4 | S: we.r. - 10 R 4/4 | r. - 2.5 YR 5/6 | H | |
| 122 | 08.1275 | L2,B3 | 2A,16 | Rs/C | M | 4S | M | S: r. - 2.5 YR 5/6 | d.g. - 5 YR 4/1 | O: l.r.br - 5 YR 6/4 I: d.g. - 5 YR 4/1 | H | 16.1 |
| 123 | 08.787 | F19,d3 | 2A.17a | D/C | M | 1 | M | l.r.br - 5 YR 6/4 | l.r.br - 5 YR 6/4 | l.r.br - 5 YR 6/4 | W | |
| 124 | 10.11 | L5,B2 | 2A.17a | P/C | M | 2P | M | r. - 10 R 5/6, r. - 10 R 4/6 | r. - 10 R 5/6, r. - 10 R 4/6 | we.r. - 10 R 5/3 | W | |
| 125 | 08.1096 | L2,B2 | 2A.17a | D/C | F | 2S | M | r.br. - 5 YR 5/3 | r.br. - 5 YR 5/3 | O: r.br. - 5 YR 5/3 C: d.g. GLEY 1 N 4 I: r.br. - 5 YR 5/3 | W | 18.2 |
| 126 | 12.9 | L9,B1 | 2A.17a | D/C | M | 1 | M | r.br. - 5 YR 5/4 | r.br. - 5 YR 5/4 | O: r.br. - 5 YR 5/4 C: br. - 7.5 YR 5/4 I: r.br. - 5 YR 5/4 | W | |
| 127 | 12.896 | L9,B8 | 2A.17a | K/K | C | 2S | M | br. - 7.5 YR 5/4 | br. - 7.5 YR 5/4 | O: br. - 7.5 YR 5/4 C: d.g. - 5 YR 4/1 I: br. - 7.5 YR 5/4 | HW | |
| 128 | 10.145 | L8,B6 | 2A.17a | Ys/C | M | 4P | M | S: v.p.br. - 10 YR 7/3 | S: v.p.br. - 10 YR 7/3 | r.y. - 5 YR 6/6 | W | |
| 129 | 12.350 | L9,B5A | 2A.17a | P/C | M | 2S | M | g.br. - 10 YR 5/2 | g.br. - 10 YR 5/2 | g.br. - 10 YR 5/2 | W | |
| 130 | 12.422 | L9,B5B | 2A.17b | P/C | M | 1 | M | r.y. - 5 YR 6/6 | r.y. - 5 YR 6/6 | O: r.y. - 5 YR 6/6 C: g. - 5 YR 5/1 I: r.y. - 5 YR 6/6 | W | |
| 131 | 12.1723 | L10,B9 | 2A.17b | P/C | M | 1 | M | pi. - 5 YR 7/4 | v.p.br. - 10 YR 8/4, pi. - 5 YR 7/4 | O: pi. - 5 YR 7/4 C: p.br. - 10 YR 6/3 I: pi. - 5 YR 7/4 | W | |
| 132 | 12.40 | L9,B2 | 2A.17b | P/C | M | 1 | M | l.r. - 2.5 YR 6/6 | l.r. - 2.5 YR 6/8 | O: l.r. - 2.5 YR 6/6 C: r.br. - 2.5 YR 4/4 I: l.r. - 2.5 YR 6/8 | W | |
| 133 | 12.1467 | L11,B8 | 2A.17b | P/C | M | 2S | M | br. - 7.5 YR 5/3 | br. - 7.5 YR 5/3 | br. - 7.5 YR 5/3 | W | |
| 134 | 09.810 | G13,a1 | 2A.18a | P/C | M | 3B | M | Ss: v.p.br. - 10 YR 7/3 | Ss: v.p.br. - 10 YR 7/3 | O: r.y. - 7.5 YR 6/6 C: g. - 7.5 YR 5/1 I: r.y. - 7.5 YR 6/6 | W | |
| 135 | 09.926 | F13,c3 | 2A.18a | P/C | M | 2S | M | l.br. - 7.5 YR 6/3 | l.r.br - 5 YR 6/4 | O: l.br. - 7.5 YR 6/3 C: y.r. - 5 YR 5/6 I: l.r.br - 5 YR 6/4 | W | |
| 136 | 08.1239 | L2,B3 | 2A.18a | D/C | M | 1 | M | l.br. - 7.5 YR 6/4 | l.br. - 7.5 YR 6/4 | O: l.br. - 7.5 YR 6/4 C: d.g. - 5 YR 4/1 I: l.br. - 7.5 YR 6/4 | W | |
| 137 | 12.2142 | L12,B6 | 2A.18a | D/C | M | 1 | M | l.r.br - 5 YR 6/3 | l.r.br - 5 YR 6/3 | O: l.r.br - 5 YR 6/3 C: d.g. - 5 YR 4/1 I: l.r.br - 5 YR 6/3 | W | |
| 138 | 12.981 | L9,B9 | 2A.18a | P-D/C | M | 1 | M | l.br. - 7.5 YR 6/4 | l.br. - 7.5 YR 6/4 | O: l.br. - 7.5 YR 6/4 C: g. - 7.5 YR 5/1 I: l.br. - 7.5 YR 6/4 | W | |
| | 08.369 | F20,b2 | 2A.18a | D/C | M | 2S | M | l.r.br - 5 YR 6/4 | l.r.br - 5 YR 6/4 | O: l.r.br - 5 YR 6/4 C: g. - 5 YR 6/1 I: l.r.br - 5 YR 6/4 | W | |



Fig. 6 – Pottery from Uşaklı Höyük.

Figure 7 – Type 2

| n. | UKn. | Area | Type | W/ Cl | E | ST | Fa | Colour (out.) | Colour (in.) | Colour (sect.) | T | Pl. |
|-----|---------|----------|--------|----------|----|-----|----|--|--|---|---|------|
| 140 | 08.2100 | L4,B4 | 2A.18a | D/C | M | 3 | M | Ss: l.br. - 7.5 YR 6/4 | Ss: l.br. - 7.5 YR 6/4 | r. - 2.5 YR 5/6 | W | |
| 141 | 08.1517 | L3,B1 | 2A.18a | D/C | F | 1 | M | r. - 2.5 YR 5/6 | r. - 2.5 YR 5/6 | r. - 2.5 YR 5/6 | W | |
| 142 | 09.89 | H18,a4 | 2A.18a | P/C | MF | 2So | M | l.r.br. - 2.5 YR 6/4, y.r. - 5 YR 5/6 | l.r.br. - 2.5 YR 6/4, y.r. - 5 YR 5/6 | O: y.r. - 5 YR 5/6 C: g. - 5 YR 5/1 I: y.r. - 5 YR 5/6 | W | |
| 143 | 08.764 | F19,b4 | 2A.18a | D/C | M | 2So | M | r. - 2.5 YR 5/6 | r. - 2.5 YR 5/6 | O: r. - 2.5 YR 5/6 C: gr.g. GLEY 1 10 Y 5/1 I: r. - 2.5 YR 5/6 | W | 18.4 |
| 144 | 12.1475 | L11,B8 | 2A.18b | P/C | M | 2S | M | r.y. - 5 YR 6/6 | r.y. - 5 YR 6/8 | O: r.y. - 5 YR 6/6 C: l.o.g. - 5 Y 6/2 I: r.y. - 5 YR 6/8 | W | |
| 145 | 08.363 | E20,b2 | 2A.18b | D/C | M | 2S | M | l.r. - 10 R 6/6 | l.r. - 10 R 6/6 | O: l.r. - 10 R 6/6 C: g. GLEY 1 N 5 I: l.r. - 10 R 6/6 | W | 18.4 |
| 146 | 09.730 | H15,b3 | 2A.18c | P/C | M | 2So | M | l.r.br. - 5 YR 6/4, y.r. - 5 YR 5/4 | l.r.br. - 5 YR 6/4, y.r. - 5 YR 5/4 | O: y.r. - 5 YR 5/4 C: g. - 5 YR 5/1 I: y.r. - 5 YR 5/4 | W | |
| 147 | 08.1748 | L3,B3 | 2A.18c | D/C | M | 1 | M | l.br. - 7.5 YR 6/3 | l.br. - 7.5 YR 6/3 | O: l.br. - 7.5 YR 6/3 C: r.y. - 5 YR 6/6 I: l.br. - 7.5 YR 6/3 | W | |
| 148 | 09.90 | H18,a4 | 2A.18c | Rs/C | M | 4B | M | S: d.r.br. - 2.5 YR 3/3 | S: d.r.br. - 2.5 YR 3/3 | O: l.br. - 7.5 YR 6/4 C: s.br. - 7.5 YR 5/6 I: l.br. - 7.5 YR 6/4 | W | |
| 149 | 12.1581 | L11,B9 | 2A.18d | D/C | M | 1 | M | y.r. - 5 YR 5/6 | y.r. - 5 YR 5/6 | y.r. - 5 YR 5/6 | W | |
| 150 | 08.418 | F20,a1 | 2A.18d | D/C | F | 3 | M | Ss: g. - 10 YR 6/1 | g. - 10 YR 6/1 | g. - 10 YR 6/1 | W | |
| 151 | 08.387 | F20,a4 | 2A.18e | D/C | M | 1 | M | l.r.br. - 5 YR 6/4 | l.r.br. - 5 YR 6/4 | l.r.br. - 5 YR 6/4 | W | |
| 152 | 09.1074 | M11,d4 | 2A.18e | D/C | M | 2S | M | l.br. - 7.5 YR 6/3, r.y. - 5 YR 6/6 | l.br. - 7.5 YR 6/3, r.y. - 5 YR 6/6 | O: l.br. - 7.5 YR 6/3 C: br. - 7.5 YR 4/4 I: l.br. - 7.5 YR 6/3 | W | |
| 153 | 08.396 | F20,a3 | 2A.18e | D/C | MF | 1 | M | l.r. - 2.5 YR 6/6 | l.r. - 2.5 YR 6/6 | l.r. - 2.5 YR 6/6 | W | |
| 154 | 08.428 | Gen. | 2A.18e | D/C | F | 2S | M | r.br. - 5 YR 5/4 | r.br. - 5 YR 5/4 | r.br. - 5 YR 5/4 | W | |
| 155 | 08.86 | J19 | 2A.18e | Rs/C | MF | 4B | M | S: r. - 2.5 YR 4/8 | S: r. - 2.5 YR 4/8 | O: l.r. - 2.5 YR 7/8 C: y.r. - 5 YR 5/6 I: l.r. - 2.5 YR 7/8 | W | |
| 156 | 12.37 | L9,B2 | 2A.18e | Rs/C | M | 4S | M | S: r. - 10 R 5/6; | r.y. - 5 YR 6/6 | O: r.y. - 5 YR 6/6 C: r.g. - 5 YR 5/2 I: r.y. - 5 YR 6/6 | W | |
| 157 | 08.2137 | L4,B4 | 2A.19a | Rs/C | M | 4B | M | S: r. - 10 R 5/6; | S: r. - 10 R 5/6 | O: r. - 2.5 YR 5/6 C: l.r. - 10 R 6/6 I: r. - 2.5 YR 5/6 | W | 28 |
| 158 | 09.935 | F13,d2 | 2A.19a | P/C | M | 2S | M | l.br. - 7.5 YR 6/4 | l.br. - 7.5 YR 6/4 | O: br. - 7.5 YR 5/3 C: g. - 7.5 YR 5/1 I: br. - 7.5 YR 5/3 | W | |
| 159 | 12.2113 | L12,B6 | 2A.19a | Rs/C | M | 4S | M | S: r. - 2.5 YR 4/6 | l.r.br. - 5 YR 6/4 | O: l.r.br. - 5 YR 6/4 C: pi.g. - 5 YR 6/2 I: l.r.br. - 5 YR 6/4 | W | |
| 160 | 08.1090 | L2,B2 | 2A.19b | P/C | M | 1 | M | r.y. - 5 YR 6/6 | r.y. - 5 YR 6/6 | r.y. - 5 YR 6/6 | W | |
| 161 | 12.1768 | L12,B1/2 | 2A.19b | Rs/C | M | 4B | M | S: l.r. - 2.5 YR 6/8 | S: l.r. - 2.5 YR 6/8 | r.y. - 5 YR 7/6 | W | |

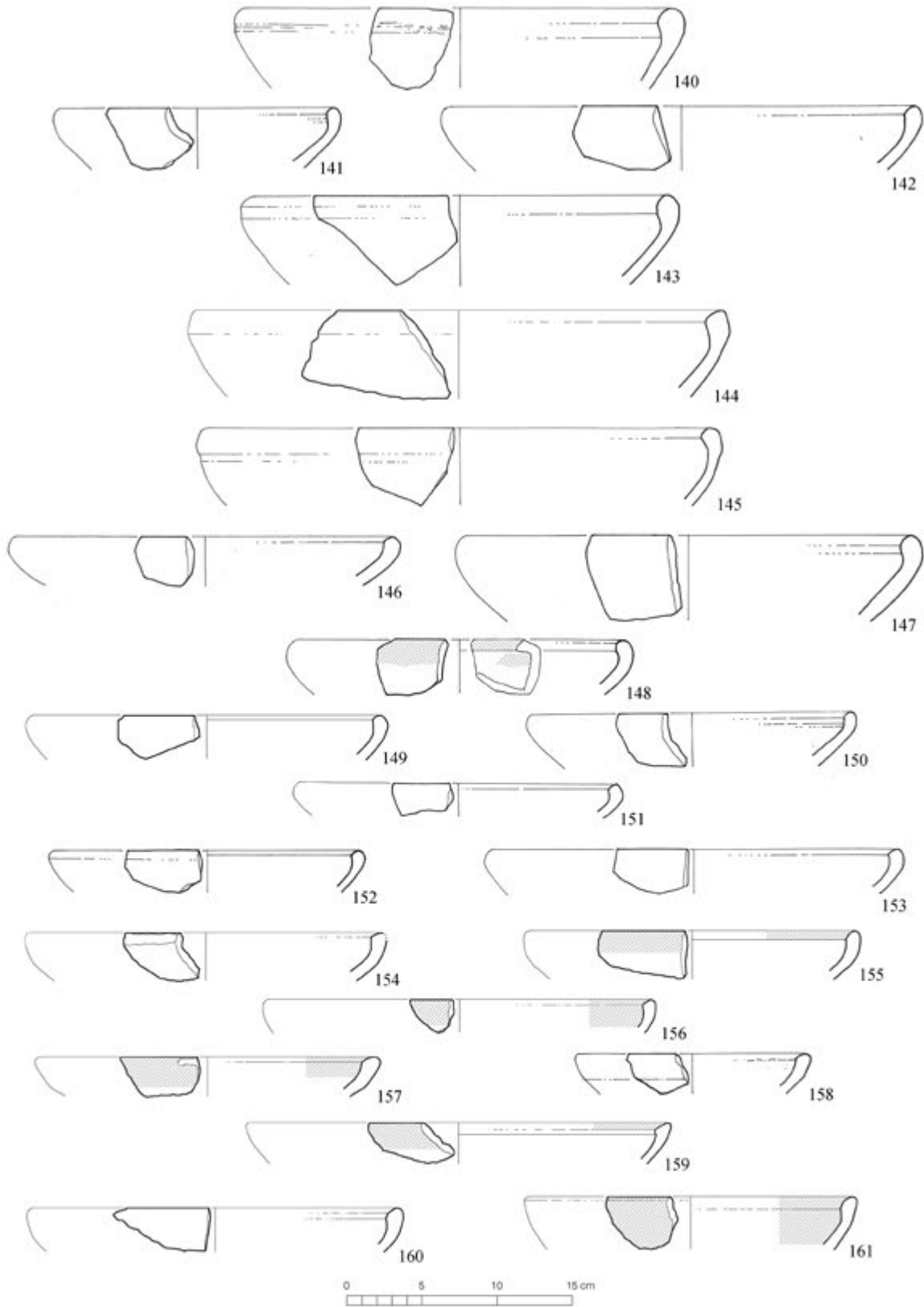


Fig. 7 – Pottery from Uşaklı Höyük.

Figure 8 – Type 2

| n. | UKn. | Area | Type | W/Cl | E | ST | Fa | Colour (out.) | Colour (in.) | Colour (sect.) | T | Pl. |
|-----|---------|--------|--------|-------|----|-----|----|---|---|--|---|------|
| 162 | 12.123 | L9,B3 | 2A.19c | Bb/C | M | 3Bo | M | Ss: r.y. - 7.5 YR 7/6 | Ss: r.y. - 7.5 YR 8/6 | O: r. - 2.5 YR 5/6 C: l.br. - 7.5 YR 6/4 I: r. - 2.5 YR 5/6 | W | |
| 163 | 12.189 | L9,B4 | 2A.19c | Pt/C | M | 4B | M | P: r.br. - 2.5 YR 4/3 S: v.p.br. - 10 YR 8/3 | P: r.br. - 2.5 YR 4/3 S: v.p.br. - 10 YR 8/3 | O: r.y. - 5 YR 7/6 C: l.g. - 5 YR 7/1 I: r.y. - 5 YR 7/6 | W | |
| 164 | 12.200 | L9,B4 | 2A.19c | G/C | M | 2Bo | M | d.r.g. - 2.5 YR 4/1 | r.br. - 2.5 YR 5/4 | O: d.r.g. - 2.5 YR 4/1 I: r.br. - 2.5 YR 5/4 | W | 21.6 |
| 165 | 12.826 | L9,B8 | 2A.19c | Ys/C | M | 4S | M | S: p.y. - 2.5 Y 8/2 | S: p.y. - 2.5 Y 8/2 | l.r.br. - 5 YR 6/4 | W | |
| 166 | 12.989 | L9,B9 | 2A.19c | Rs/C | M | 4B | M | S: r. - 2.5 YR 5/6 | S: r. - 2.5 YR 5/6 | l.r. - 2.5 YR 6/6 | W | |
| 167 | 08.665 | I19,d2 | 2A.19c | Bb/C | M | 2B | M | l.r. - 10 R 6/8 | l.r. - 10 R 6/8 | O: l.r. - 10 R 6/8 C: l.r. - 10 R 6/6 I: l.r. - 10 R 6/8 | W | 29 |
| 168 | 12.655 | L9,B7 | 2A.19c | Rs/C | M | 4Bo | M | S: we.r. - 10 R 4/4 | S: we.r. - 10 R 4/4 | r.y. - 5 YR 6/6 | W | |
| 169 | 12.553 | L9,B6 | 2A.19d | Bb/C | M | 4Bo | M | S: r.y. - 7.5 YR 6/6 | S: r.br. - 5 YR 5/4 | y.r. - 5 YR 5/8 | W | |
| 170 | 12.214 | L9,B4 | 2A.19d | Ys/C | M | 3S | M | Ss: p.y. - 2.5 Y 8/3 | Ss: p.y. - 2.5 Y 8/3 | l.r. - 2.5 YR 6/8 | W | |
| 171 | 08.298 | F20,d2 | 2A.20a | D/C | M | 1 | M | y.r. - 5 YR 5/6 | y.r. - 5 YR 5/6 | O: y.r. - 5 YR 5/6 C: g. - 5 YR 6/1 I: y.r. - 5 YR 5/6 | W | |
| 172 | 08.417 | F20,a1 | 2A.20a | P/C | M | 3S | M | Ss: l.r. - 10 R 6/6 | r.y. - 5 YR 6/6 | O: r.y. - 5 YR 6/6 C: g. - 5 YR 5/1 I: r.y. - 5 YR 6/6 | W | |
| 173 | 12.704 | L9,B7 | 2A.20b | P/C | M | 2S | M | v.p.br. - 10 YR 7/3, pi. - 5 YR 7/4 | pi. - 5 YR 7/4 | O: pi. - 5 YR 7/4 C: g. - 10 YR 5/1 I: pi. - 5 YR 7/4 | W | |
| 174 | 12.819 | L9,B8 | 2A.20b | P-D/C | M | 1 | M | r.y. - 5 YR 6/6 | r.y. - 5 YR 6/6 | O: r.y. - 5 YR 6/6 C: g. - 5 YR 5/1 I: r.y. - 5 YR 6/6 | W | |
| 175 | 08.817 | F19,b2 | 2A.20b | D/C | M | 3 | M | Ss: r.y. - 5 YR 6/6 | Ss: r.y. - 5 YR 6/6 | r.y. - 5 YR 6/8 | W | |
| 176 | 12.329 | L9,B5A | 2A.20b | P/C | M | 1 | M | y.br. - 10 YR 5/4 | y.br. - 10 YR 5/4 | y.br. - 10 YR 5/4 | W | |
| 177 | 12.333 | L9,B5A | 2A.20c | Bb/C | M | 2B | M | y.br. - 10 YR 5/4 | y.br. - 10 YR 5/4 | O: y.br. - 10 YR 5/4 C: o.y. - 2.5 Y 6/6 I: y.br. - 10 YR 5/4 | W | |
| 178 | 12.919 | L9,B8 | 2A.20d | Pt/F | MF | 4P | M | P: v.d.g. - 5 YR 3/1 S: r. - 2.5 YR 5/6 | P: v.d.g. - 5 YR 3/1 S: r. - 2.5 YR 5/6 | r.br. - 5 YR 5/3 | W | |
| 179 | 08.692 | I19,c2 | 2A.20d | Pt/C | M | 1 | M | P: r.br. - 2.5 YR 4/3 s: l.r.br. - 5 YR 6/4 | P: r.br. - 2.5 YR 4/3 s: l.r.br. - 5 YR 6/4 | O: l.r.br. - 5 YR 6/4 C: g. - 5 YR 6/1 I: l.r.br. - 5 YR 6/4 | W | |
| 180 | 12.423 | L9,B5B | 2A.20d | Bb/C | MC | 3B | M | Ss: r.y. - 7.5 YR 6/6 | r.y. - 7.5 YR 6/6 | r.y. - 7.5 YR 6/6 | W | |
| 181 | 08.2064 | L4,B3 | 2A.20e | Bb/C | F | 2B | M | r. - 2.5 YR 5/6 | r. - 2.5 YR 5/6 | O: r. - 2.5 YR 5/6 C: r.g. - 5 YR 5/2 I: r. - 2.5 YR 5/6 | W | 29 |
| 182 | 12.336 | L9,B5A | 2A.20e | D/C | M | 1 | M | br. - 10 YR 4/3 | r.y. - 5 YR 6/6 | O: br. - 10 YR 4/3 C: we.r. - 2.5 YR 4/2 I: r.y. - 5 YR 6/6 | W | |
| 183 | 12.110 | L9,B3 | 2A.21 | Rs/C | M | 4Bo | M | S: l.r. - 2.5 YR 6/6 | S: l.r. - 2.5 YR 6/6 | l.br. - 7.5 YR 6/3 | W | |
| 184 | 09.967 | L9,c1 | 2A.22a | Pt/C | MF | 3B | M | P: r.br. - 5YR4/3 Ss: br. - 7.5YR5/3 | P: r.br. - 5YR4/3 Ss: gr. - 10YR6/1 | O: l.r. - 10 R 6/6 I: d.r.g. - 10 R 4/1 | W | 25.4 |
| 185 | 12.332 | L9,B5A | 2A.22a | Bb/C | M | 3B | M | Ss: r. - 2.5 YR 5/8 | r.y. - 5 YR 6/8 | O: r.y. - 5 YR 6/8 C: o.y. - 2.5 Y 6/6 I: r.y. - 5 YR 6/8 | W | |
| 186 | 08.523 | G19,c2 | 2A.22a | Pt/C | M | 4B | M | P: we.r. - 10 R 4/4 S: r. - 2.5 YR 5/6 | P: we.r. - 10 R 4/4 S: r. - 2.5 YR 5/6 | r.br. - 2.5 YR 5/4 | W | |
| 187 | 09.107 | H18,b4 | 2A.22b | Pt/F | F | 2Bo | M | P: du.r. - 2.5 YR 3/2 s: l.br.g. - 10 YR 6/2 | P: du.r. - 2.5 YR 3/2 s: l.br.g. - 10 YR 6/2 | O: l.br.g. - 10 YR 6/2 C: l.y.br. - 10 YR 6/4 I: l.br.g. - 10 YR 6/2 | W | 25.4 |
| 188 | 12.920 | L9,B8 | 2A.22b | Pt/C | M | 4S | M | P: d.r.g. - 5 YR 4/2 S: r.br. - 5 YR 5/4; | br. - 7.5 YR 4/3 | O: br. - 7.5 YR 4/3 C: d.g. - 7.5 YR 4/1 I: br. - 7.5 YR 4/3 | W | |
| 189 | 12.342 | L9,B5A | 2A.22b | Pt/C | M | 4B | M | P: r.br. - 5 YR 5/4 S: p.y. - 2.5 Y 8/3 | S: p.y. - 2.5 Y 8/3 | r. - 2.5 YR 5/8 | W | |
| 190 | 09.1214 | D14,a1 | 2A.22c | Pt/C | M | 4Bo | M | P: we.r. - 10 R 4/4 S: r.y. - 5 YR 6/6 | P: we.r. - 10 R 4/4 S: l.r. - 2.5 YR 6/8 | O: r. - 2.5 YR 5/6 C: g. - 5 YR 5/1 I: r. - 2.5 YR 5/6 | W | 25.2 |
| 191 | 12.337 | L9,B5A | 2A.22c | Rs/C | M | 4S | M | S: r. - 2.5 YR 4/6 | S: r. - 2.5 YR 4/6 | l.r. - 2.5 YR 6/6 | W | |
| 192 | 09.767 | H15,c1 | 2A.22c | P/C | M | 2B | M | p.y. - 2.5 Y 7/3 | g. - 2.5 Y 5/1 | O: p.y. - 2.5 Y 7/3 C: g.br. - 2.5 Y 5/2 I: g. - 2.5 Y 5/1 | W | |

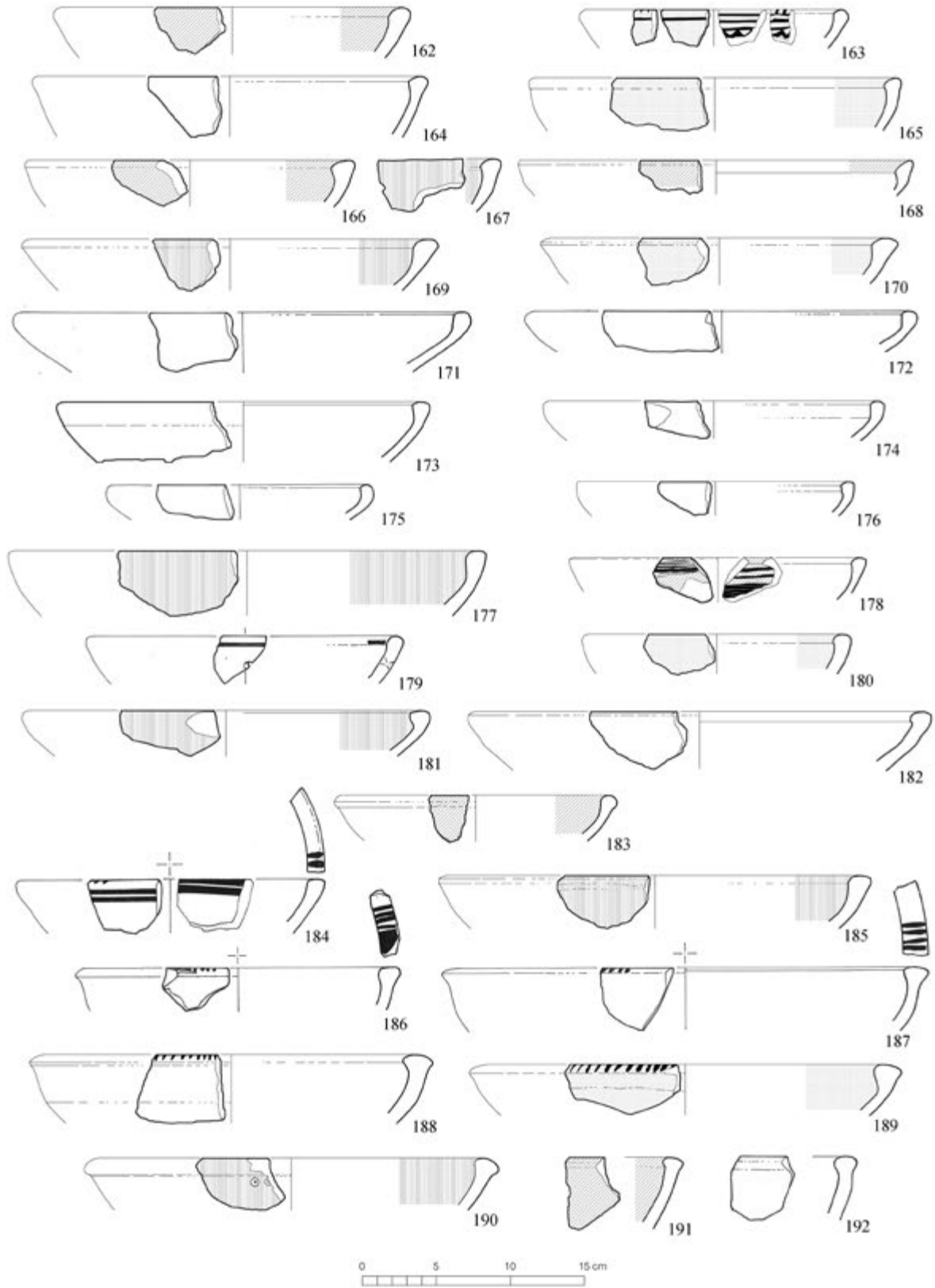


Fig. 8 – Pottery from Uşaklı Höyük.

Figure 9 – Type 2

| n. | UKn. | Area | Type | W/Cl | E | ST | Fa | Colour (out.) | Colour (in.) | Colour (sect.) | T | Pl. |
|-----|---------|--------|--------|------|----|-------|----|---|---|---|---|------|
| 193 | 12.426 | L9,B5B | 2A.22c | P/C | M | 2S | M | br. - 7.5 YR 5/2 | br. - 7.5 YR 5/2 | br. - 7.5 YR 5/2 | W | |
| 194 | 10.81 | L5,B5 | 2A.23 | Pt/C | M | 4B | M | P: d.r.g. - 5 YR 4/2 S: l.br. - 7.5 YR 6/4 | pi. - 7.5 YR 7/4 s: r.y. - 5 YR 6/6 | r.y. - 5 YR 6/6 | W | |
| 195 | 10.118 | L7,B6 | 2A.23 | Bb/C | M | 3B | M | Ss: l.r.br - 5 YR 6/4 | r.br. - 5 YR 5/4 | O: l.r.br - 5 YR 6/4 C: y.r. - 5 YR 5/6 I: r.br. - 5 YR 5/4 | W | |
| 196 | 09.1101 | D9,d2 | 2A.23 | Bb/F | M | 3B | M | Ss: l.r.br - 5 YR 6/4 | Ss: l.r.br - 5 YR 6/4 | y.r. - 5 YR 5/6 | W | 21.7 |
| 197 | 09.966 | L9,c1 | 2A.23 | Bb/C | MF | 2Bo | M | pi.g. - 7.5 YR 6/2, pi. - 7.5 YR 7/4 | pi.g. - 7.5 YR 6/2, pi. - 7.5 YR 7/4 | O: pi.g. - 7.5 YR 6/2 C: g. - 7.5 YR 5/1 I: pi.g. - 7.5 YR 6/2 | W | |
| 198 | 12.842 | L9,B8 | 2A.23 | Bb/C | C | 3Bo | M | Ss: pi. - 5 YR 7/4 | pi. - 5 YR 7/4 | pi. - 5 YR 7/4 | W | |
| 199 | 12.667 | L9,B7 | 2A.23 | Rs/C | M | 4B | M | S: r. - 10 R 4/6 | S: r. - 10 R 4/6 | r. - 2.5 YR 5/8 | W | |
| 200 | 12.1155 | L11,B4 | 2A.24 | P/C | MC | 1 | M | l.r. - 2.5 YR 6/6, r.br. - 5 YR 5/3 | r.y. - 5 YR 6/6 | O: l.r. - 2.5 YR 6/6 I: r.y. - 5 YR 6/6 | W | |
| 201 | 12.532 | L9,B6 | 2A.25 | Rs/C | MC | 4 | M | S: r. - 10 R 5/6 | S: r. - 10 R 5/6 | O: l.r. - 2.5 YR 6/8 C: o.y. - 5 Y 6/6 I: l.r. - 2.5 YR 6/8 | W | |
| 202 | 12.196 | L9,B4 | 2A.26 | P/C | MC | 2So | M | r.y. - 5 YR 7/6 | r.y. - 5 YR 7/6 | r.y. - 5 YR 7/6 | W | |
| 203 | 12.1956 | L12,B4 | 2A.26 | Ps/C | M | 3Bo+b | M | Ss: l.r. - 2.5 YR 6/8 | Ss: l.r. - 2.5 YR 6/8 | l.o.br. - 2.5 Y 5/3 | W | |
| 204 | 08.649 | I19,d4 | 2A.27a | Pt/C | F | 4B | M | S: v.p.br. - 10 YR 7/4 | P: d.g. - 7.5 YR 4/1 S: v.p.br. - 10 YR 7/4; | l.r.br. - 5 YR 6/4 | W | |
| 205 | 12.425 | L9,B5B | 2A.27a | Rs/C | M | 4B | M | S: r. - 10 R 5/6; | r.y. - 5 YR 6/6 | O: br. - 7.5 YR 4/2 I: r.y. - 5 YR 6/6 | W | |
| 206 | 09.946 | L9,B2 | 2A.27a | P/C | M | 3Bo | M | S: br. - 7.5 YR 4/2 | pi.g. - 7.5 YR 6/2 | O: br. - 7.5 YR 5/3 C: pi.g. - 7.5 YR 7/2 I: pi.g. - 7.5 YR 6/2 | W | |
| 207 | 12.45 | L9,B2 | 2A.27b | Ys/C | M | 4Bo | M | S: v.p.br. - 10 YR 8/3 | S: v.p.br. - 10 YR 8/3 | l.r. - 2.5 YR 6/8 | W | |
| 208 | 12.42 | L9,B2 | 2A.27b | P/C | M | 3S | M | Ss: r.br. - 5 YR 5/4 | r.br. - 5 YR 5/4 | r.br. - 5 YR 5/4 | W | |
| 209 | 09.231 | G15,d4 | 2A.27b | Cg/C | M | 2So | M | pi.g. - 7.5 YR 6/2 | l.r. - 2.5 YR 6/6 | O: pi.g. - 7.5 YR 6/2 C: l.r. - 2.5 YR 6/8, r.g. - 2.5 YR 6/1 I: l.r. - 2.5 YR 6/6 | W | |
| 210 | 09.988 | L8,d4 | 2A.28 | P/C | MF | 2Bo | M | r. - 2.5 YR 5/6, l.r. - 2.5 YR 6/6 | l.r. - 2.5 YR 7/6, l.r. - 2.5 YR 6/6 | O: l.r. - 2.5 YR 6/6 C: r.g. - 10 R 6/1 I: l.r. - 2.5 YR 6/6 | W | 21.7 |
| 211 | 09.802 | G13,a4 | 2A.28 | Cg/C | M | 2S | M | br. - 7.5 YR 5/2, br. - 7.5 YR 5/3 | br. - 7.5 YR 5/2, br. - 7.5 YR 5/3 | O: br. - 7.5 YR 5/2 C: d.g. - 7.5 YR 4/1 I: br. - 7.5 YR 5/2 | W | 26.5 |

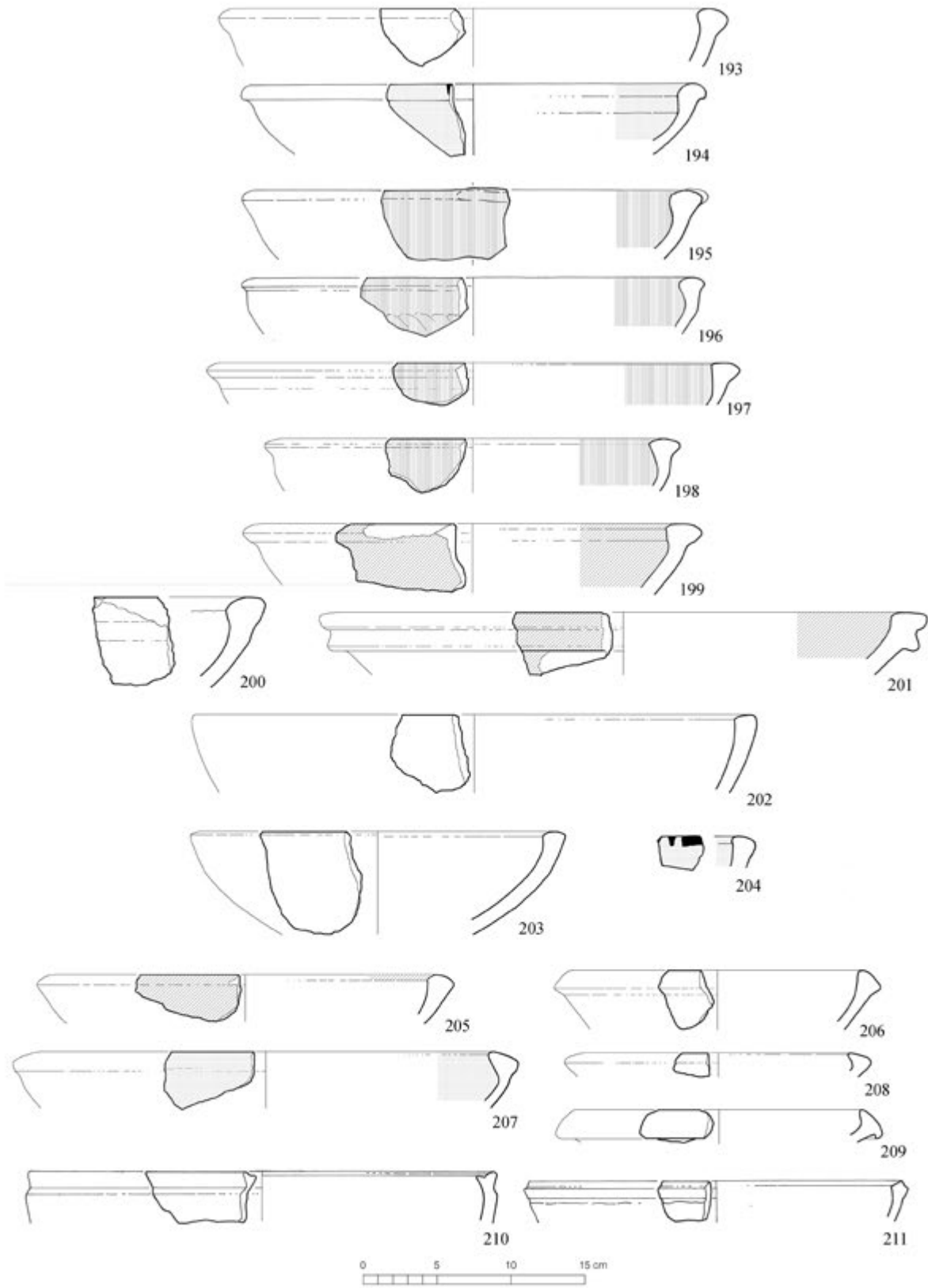


Fig. 9 – Pottery from Uşaklı Höyük.

Figure 10 – Type 2

| n. | UKn. | Area | Type | W/Cl | E | ST | Fa | Colour (out.) | Colour (in.) | Colour (sect.) | T | Pl. |
|-----|---------|----------|--------|---------|----|------|----|---|--|--|---|--------------|
| 212 | 08.262 | K19,c3 | 2A.29a | Bb/F | MF | 3B | M | Ss: r.y. - 5 YR 6/6 | r.br. - 2.5 YR 4/3 | r.br. - 2.5 YR 4/3 | W | 26.2 |
| 213 | 12.343 | L9,B5A | 2A.29b | Ys/C | MC | 4S | M | S: p.y. - 2.5 Y 7/4 | S: p.y. - 2.5 Y 7/4 | r.y. - 5 YR 6/6 | W | |
| 214 | 09.615 | H13,d2 | 2A.29b | P/C | F | 2S | M | l.br. - 7.5 YR 6/4 | l.br. - 7.5 YR 6/4 | O: l.br. - 7.5 YR 6/4 C: r.y. - 5 YR 6/6 I: l.br. - 7.5 YR 6/4 | W | |
| 215 | 12.51 | L9,B2 | 2A.29b | Ys-Rs/C | M | 4B | M | S: du.r. - 10 R 3/4, y. - 10 YR 8/6; | r. - 2.5 YR 5/8 | O: r.y. - 5 YR 6/6 I: r. - 2.5 YR 5/8 | W | |
| 216 | 12.131 | L9,B3 | 2A.29b | Bb/C | M | 3Bo | M | Ss: l.y.br. - 10 YR 6/4 | l.y.br. - 10 YR 6/4 | l.y.br. - 10 YR 6/4 | W | |
| 217 | 12.1853 | L12,B1/2 | 2A.30 | Pt/F | MF | 3S | M | Ss: r.y. - 5 YR 6/6 | P: v.d.g. - 7.5 YR 3/1 s: r.y. - 5 YR 6/6 | O: r.y. - 5 YR 6/6 C: pi. - 7.5 YR 7/4 I: r.y. - 5 YR 6/6 | W | |
| 218 | 12.1334 | L11,B6 | 2A.30 | Pt/F | MF | 4P | M | S: r.y. - 7.5 YR 6/6 | P: du.r. - 2.5 YR 3/2 s: l.br. - 7.5 YR 6/4 | O: l.br. - 7.5 YR 6/4 C: br. - 7.5 YR 5/4 I: l.br. - 7.5 YR 6/4 | W | |
| 219 | 09.528 | G14,b1 | 2A.30 | Pt/C | M | 4Bo | M | S: p.y. - 5 Y 8/2 | P: d.r.g. - 5 YR 4/2 S: v.p.br. - 10 YR 7/3 | y.r. - 5 YR 5/6 | W | 23.2 25.1 |
| 220 | 09.1272 | L2,B2 | 2A.30 | G/C | MF | 2B | M | d.g. - 5 YR 4/1 | g. - GLEY 1 N 6 | O: d.g. - 5 YR 4/1 C: d.g. - GLEY 1 N 4 I: g. - GLEY 1 N 6 | W | 21.3 |
| 221 | 12.757 | L9,B7 | 2A.30 | Pt/F | MF | 4B | M | P: d.r.g. - 2.5 YR 3/1 S: l.br. - 7.5 YR 6/4 | S: l.br. - 7.5 YR 6/4 | r.y. - 7.5 YR 6/6 | W | |
| 222 | 12.357 | L9,B5A | 2A.31 | Rs/F | MF | 4B | M | S: l.r. - 2.5 YR 6/6 | S: l.r. - 2.5 YR 6/6 | r. - 10 R 5/6 | W | |
| 223 | 08.1086 | L2,B2 | 2B.1 | Gw/F | FF | 4P | M | S: r.y. - 7.5 YR 7/6 | S: y. - 10 YR 7/4 | y.r. - 5 YR 5/8 | W | 26.2 31 |
| 224 | 08.2206 | F20,d3 | 2B.1 | Rs/F | F | 4B | M | S: r. - 2,5 YR 5/6 | S: r. - 2,5 YR 5/6 | O: l.r. - 2.5 YR 6/6 C: r.g. - 2.5 YR 5/1 I: l.r. - 2.5 YR 6/6 | W | |
| 225 | 09.1140 | L1,B2A | 2B.1 | Gw/F | F | 4Bo | MV | S: p.w. - 7.5 YR 8/2 | S: p.w. - 7.5 YR 8/2 | O: r. - 2.5 YR 5/8 C: g. - GLEY 1 N 5 I: r. - 2.5 YR 5/8 | W | |
| 226 | 08.435 | G19,a4 | 2B.1 | Rs/F | M | 4B | M | S: we.r. - 10 R 5/4 | r. - 2.5 YR 5/6 | O: r. - 2.5 YR 5/6 C: d.g. - GLEY 1 N 4 I: r. - 2.5 YR 5/6 | W | |
| 227 | 09.69 | H16,d4 | 2B.1 | P/F | F | 2S | M | l.br. - 7.5 YR 6/3 | l.br. - 7.5 YR 6/3 | O: l.br. - 7.5 YR 6/3 C: l.br. - 7.5 YR 6/4 I: l.br. - 7.5 YR 6/3 | W | |
| 228 | 12.104 | L9,B3 | 2B.1 | Rs/F | M | 4S | M | S: r. - 10 R 5/6 | S: r. - 10 R 5/6 | O: r. - 2.5 YR 5/6 C: d.r.g. - 2.5 YR 4/1 I: r. - 2.5 YR 5/6 | W | |
| 229 | 12.780 | L9,B8 | 2B.1 | Rs/F | MF | 4S | M | S: r.br. - 2.5 YR 5/3 | S: r.br. - 2.5 YR 5/3 | O: r.y. - 5 YR 6/6 C: g. - 2.5 Y 5/1 I: r.y. - 5 YR 6/6 | W | |
| 230 | 12.416 | L9,B5B | 2B.1 | Rb/F | F | 4P | M | S: r.b. - 2.5 YR 4/4, r. - 2.5 YR 5/6 | S: r.b. - 2.5 YR 4/4, r. - 2.5 YR 5/6 | r.b. - 5 YR 5/3 | W | |
| 231 | 12.102 | L9,B3 | 2B.1 | Rb/F | F | 4Bo | M | S: r.b. - 2.5 YR 4/4, r. - 2.5 YR 5/6 | S: r.b. - 2.5 YR 4/4, r. - 2.5 YR 5/6 | r.b. - 5 YR 5/4 | W | |
| 232 | 12.505 | L9,B6 | 2B.1 | Rs/F | F | 4Bo | M | S: we.r. - 10 R 4/4 | y.r. - 5 YR 5/6 | O: y.r. - 5 YR 5/6 C: g. - 2.5 Y 5/1 I: y.r. - 5 YR 5/6 | W | |
| 233 | 09.1145 | L1,B3A | 2B.1 | Rs/F | F | 4Bo | M | S: we.r. - 10 R 4/2 | S: we.r. - 10 R 4/2 | O: r.g. - 2.5 YR 5/1, d.r.g. - 5 YR 4/2 C: d.g. - 7.5 YR 4/1 I: r.g. - 2.5 YR 5/1, d.g. - 5 YR 4/1 | W | |
| 234 | 10.56 | L8,B3 | 2B.2a | D/C | M | 1 | M | r.br. - 5 YR 5/3 | r.br. - 5 YR 5/4 | O: r.br. - 5 YR 5/3 C: d.r.g. - 5 YR 4/2 I: r.br. - 5 YR 5/3 | W | |
| 235 | 08.1220 | L2,B3 | 2B.2a | Rs/F | F | 4S | M | S: we.r. - 10 R 4/4 | S: we.r. - 10 R 4/4 | r.br. - 5 YR 4/4 | W | 16.4 |
| 236 | 12.7 | L9,B1 | 2B.2b | Bb/C | M | 2Bo | M | r.y. - 5 YR 6/6 | r.y. - 5 YR 6/6 | r.y. - 5 YR 6/6 | W | |
| 237 | 12.830 | L9,B8 | 2B.2b | Bb/C | M | 3B | M | Ss: br. - 7.5 YR 5/4 | Ss: br. - 7.5 YR 5/4 | y.r. - 5 YR 5/6 | W | |
| 238 | 12.2115 | L12,B6 | 2B.2b | Rs/C | M | 4B-P | M | S: r. - 2.5 YR 4/8 | S: r. - 2.5 YR 4/8 | O: l.r. - 2.5 YR 7/8 C: r.g. - 2.5 YR 6/1 I: l.r. - 2.5 YR 7/8 | W | |
| 239 | 12.222 | L9,B4 | 2B.2b | Rs/C | MF | 4P | M | S: r. - 10 R 5/8 | S: r. - 10 R 5/8 | l.r. - 2.5 YR 6/8 | W | |
| 240 | 08.1097 | L2,B2 | 2B.2b | Rs/C | M | 4B | M | S: r. - 2.5 YR 4/6 | S: r. - 2.5 YR 4/6 | O: l.r. - 2.5 YR 7/8 C: r.br. - 5 YR 5/4 I: l.r. - 2.5 YR 7/8 | W | |
| 241 | 08.1390 | L2,B4 | 2B.2b | Rs/C | M | 4B | M | S: r.br. - 5 YR 5/3 | d.g. GLEY 1 N 4 | O: l.br. - 7.5 YR 6/4 I: d.g. GLEY 1 N 4 | W | |
| 242 | 08.857 | Gen. | 2B.2b | Rs/C | M | 4B | M | S: we.r. - 10 R 4/4 | S: we.r. - 10 R 4/4 | y.r. - 5 YR 5/6 | W | |
| 243 | 12.44 | L9,B2 | 2B.2b | Rs/C | M | 4Bo | M | S: l.br.g. - 10 YR 6/2 | r. - 2.5 YR 5/6 | O: we.r. - 2.5 YR 5/2 I: r. - 2.5 YR 5/6 | W | |
| 244 | 12.223 | L9,B4 | 2B.2b | Rs/C | M | 4S | M | S: r. - 10 R 5/8 | S: r. - 10 R 5/8 | l.r. - 2.5 YR 6/8 | W | |

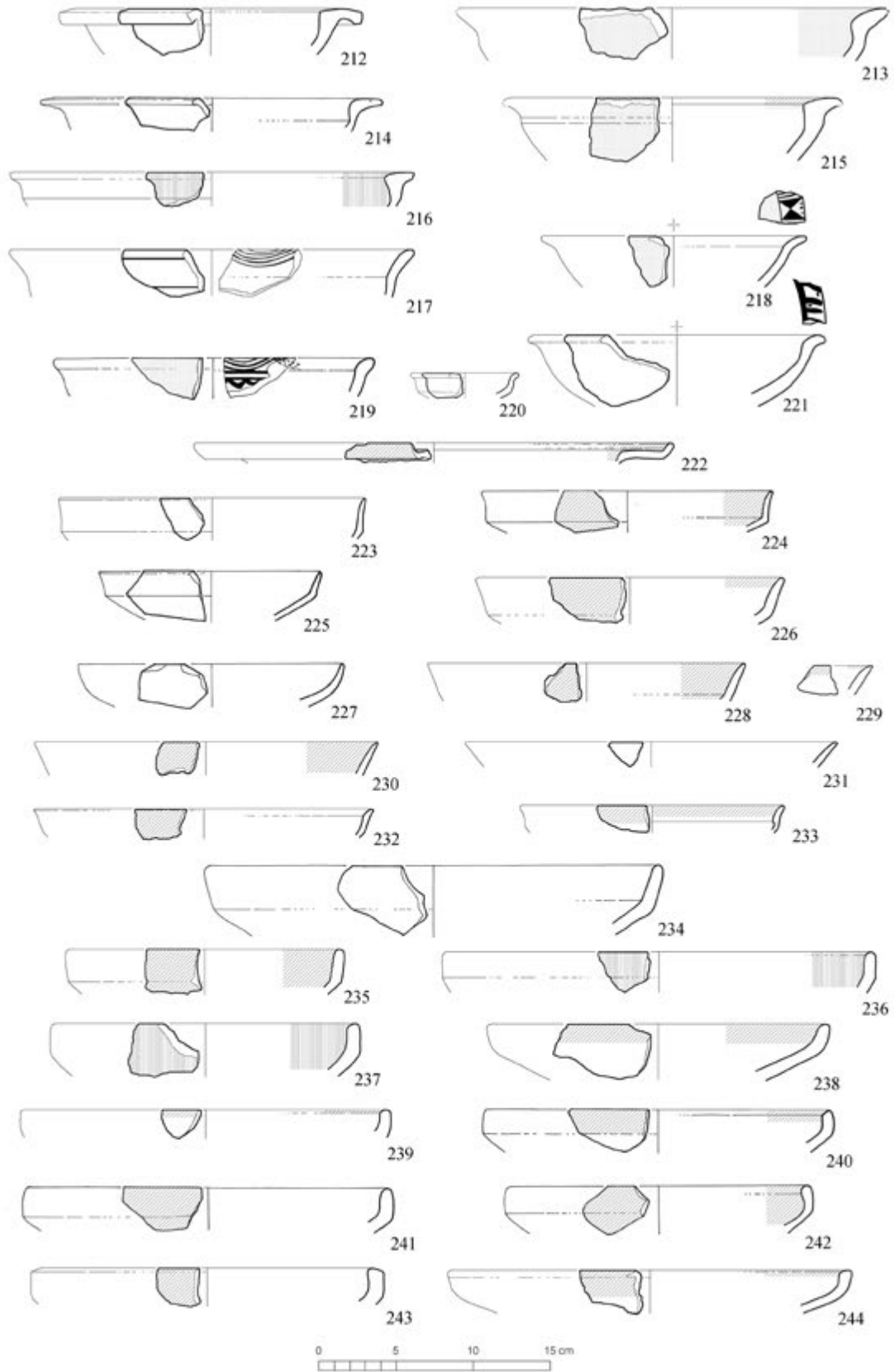


Fig. 10 – Pottery from Uşaklı Höyük.

Figure 11 – Type 2

| n. | UKn. | Area | Type | W/Cl | E | ST | Fa | Colour (out.) | Colour (in.) | Colour (sect.) | T | Pl. |
|-----|-----------|----------|-------|-------|----|-------|----|-----------------------------------|-----------------------------------|---|---|------------|
| 245 | 08.470 | G19,d1 | 2B.2b | Rs/C | M | 4B | M | S: we.r. - 10 r 5/4 | S: we.r. - 10 r 5/4 | O: r.br. - 5 YR 5/4 C: d.g. GLEY 1 N 4 I: r.br. - 5 YR 5/4 | W | |
| 246 | 08.1356 | L2,B4 | 2B.2b | Rs/C | M | 2B | M | we.r. - 10 r 5/3, r. - 2.5 YR 5/6 | we.r. - 10 r 5/3, r. - 2.5 YR 5/6 | O: r. - 2.5 YR 5/6 C: v.d.g. GLEY 1 N 3 I: r. - 2.5 YR 5/6 | W | 16.2 |
| 247 | 12.973 | L9,B9 | 2B.2c | Rs/C | M | 4 | M | S: we.r. - 10 r 5/4 | S: we.r. - 10 r 5/4 | O: y.r. - 5 YR 5/6 C: br. - 7.5 YR 5/4 I: y.r. - 5 YR 5/6 | W | |
| 248 | 12.947 | L9,B9 | 2B.2c | Rs/C | M | 4B | M | S: we.r. - 10 r 5/4 | S: we.r. - 10 r 5/4 | r.br. - 5 YR 5/4 O: r. - 2.5 YR 5/6 | W | |
| 249 | 08.1558 | L3,B2 | 2B.2c | Rs/C | M | 4 | M | S: we.r. - 10 r 5/4 | S: we.r. - 10 r 5/4 | C: d.g. GLEY 1 N 4 I: r. - 2.5 YR 5/6 | W | 28 |
| 250 | 12.789 | L9,B8 | 2B.2c | Rs/C | M | 4Bo | M | S: r. - 10 R 5/6 | S: r. - 10 R 5/6 | O: l.r. - 2.5 YR 6/8 C: r.br. - 5 YR 5/4 I: l.r. - 2.5 YR 6/8 | W | |
| 251 | 10.130 | L7,B6 | 2B.2c | G/C-F | MF | 2Bo | M | r.g. - 10 R 5/1 | r.g. - 10 R 5/1 | O: r.g. - 10 R 5/1 C: d.bl.g. GLEY 2 5PB 4/1 I: r.g. - 10 R 5/1 | W | |
| 252 | 08.1452 | L2,B5 | 2B.3 | Rs/C | M | 3B+4B | M | S: r. - 10 R 4/6 | S: r. - 10 R 4/6 | O: r. - 2.5 YR 5/6 C: g. GLEY 1 N 6 I: r. - 2.5 YR 5/6 | W | |
| 253 | 12.1868 | L12,B3 | 2B.3 | Rs/C | M | 4S | M | S: r. - 10 R 5/6 | S: r. - 10 R 5/6 | r. - 2.5 YR 5/6 | W | |
| 254 | 09.623 | H13,d1 | 2B.3 | Rs/C | M | 4B | M | S: r. - 10 R 4/6 | S: l.r. - 2.5 YR 6/6 | O: r. - 2.5 YR 5/8 C: s.br. - 7.5 YR 5/6 I: r. - 2.5 YR 5/8 | W | |
| 255 | 10.186 | L7,B8 | 2B.3 | P/C | MF | 2S | M | l.br. - 7.5 YR 6/4 | r.y. - 5 YR 6/6 | O: l.br. - 7.5 YR 6/4 C: d.g. - 7.5 YR 4/1 I: r.y. - 5 YR 6/6 | W | |
| 256 | 08.574 | H19,a2 | 2B.4a | Rs/C | M | 4B | M | S: r. - 10 R 5/6 | S: r. - 10 R 5/6 | O: l.r.br. - 2.5 YR 6/4 C: g. GLEY 1 N 5 I: l.r.br. - 2.5 YR 6/4 | W | |
| 257 | 08.1327 | L2,B4 | 2B.4a | Rs/C | M | 4S | M | S: r. - 10 R 4/6 | r. - 2.5 YR 5/6 | O: r. - 2.5 YR 5/6 C: d.g. GLEY 1 N 4 I: r. - 2.5 YR 5/6 | W | |
| 258 | 12.786 | L9,B8 | 2B.4a | Rs/C | M | 4Bo | M | S: br. - 7.5 YR 4/3 | S: br. - 7.5 YR 4/3 | O: l.r.br. - 2.5 YR 6/4 C: br. - 7.5 YR 5/3 I: l.r.br. - 2.5 YR 6/4 | W | |
| 259 | 08.799 | F19,b3 | 2B.4a | Rs/C | F | 4B | M | S: r.br. - 5 YR 5/3 | r.y. - 5 YR 6/6 | r.y. - 5 YR 6/6 | W | 16.1 |
| 260 | 12.1764 | L12,B1/2 | 2B.4a | Rs/C | M | 4Bo | M | S: y.r. - 5 YR 4/6 | S: y.r. - 5 YR 4/6 | y.r. - 5 YR 5/6 | W | |
| 261 | 08.1821 | L3,B4 | 2B.4a | Rs/C | M | 4P | M | S: r. - 10 R 4/8 | S: r. - 10 R 4/8 | w.r. - 10 R 5/4 | W | |
| 262 | 09.314 | F16,c3 | 2B.4a | Rs/C | M | 4B | M | S: r. - 10 R 5/6 | y.r. - 5 YR 5/6 | O: y.r. - 5 YR 5/6 C: r.br. - 5 YR 5/4 I: y.r. - 5 YR 5/6 | W | 16.1 |
| 263 | 12.793 | L9,B8 | 2B.4a | Rs/C | M | 4S | M | S: we.r. - 10 R 4/4 | S: we.r. - 10 R 4/4 | O: y.r. - 5 YR 5/6 C: d.g. - 5 YR 4/1 I: y.r. - 5 YR 5/6 | W | |
| 264 | 12.1555 | L11,B9 | 2B.4a | Rs/C | M | 4S | M | S: r. - 10 R 5/6 | S: r. - 10 R 5/6 | O: l.r.br. - 5 YR 6/4 C: r.y. - 7.5 YR 6/6 I: l.r.br. - 5 YR 6/4 | W | |
| 265 | 12.34 | L9,B2 | 2B.4a | Rs/C | M | 4Bo | M | S: r. - 10 R 5/8 | S: r. - 10 R 5/8 | O: l.r.br. - 5 YR 6/4 C: r.y. - 5 YR 6/6 I: l.r.br. - 5 YR 6/4 | W | |
| 266 | 08.1237/8 | L2,B3 | 2B.4b | Rs/C | M | 4P | M | S: l.r. - 2.5 YR 6/6 | S: l.r. - 2.5 YR 6/6 | O: y.r. - 5 YR 5/6 C: pi.g. - 7.5 YR 6/2 I: y.r. - 5 YR 5/6 | H | 15.528 |
| 267 | 08.1392 | L2,B4 | 2B.4b | Rs/C | F | 4 | M | S: we.r. - 10 R 5/4 | S: we.r. - 10 R 5/4 | O: l.r. - 2.5 YR 6/6 C: d.g. GLEY 1 N 4 I: l.r. - 2.5 YR 6/6 | W | 16.4 |
| 268 | 08.1566 | L3,B2 | 2B.4b | Rs/C | F | 4B | M | S: we.r. - 10 R 5/4 | S: we.r. - 10 R 5/4 | y.r. - 5 YR 5/6 | W | |
| 269 | 12.1089 | L11,B3 | 2B.4b | Rs/C | M | 4S | M | S: r.br. - 2.5 YR 5/4 | l.r.br. - 5 YR 6/4 | O: y.r. - 5 YR 5/6 C: r.g. - 5 YR 5/2 I: l.r.br. - 5 YR 6/4 | W | |
| 270 | 09.913 | F13,a2 | 2B.4b | Rs/C | M | 4Bo | M | S: r. - 2.5 YR 5/8 | S: r. - 2.5 YR 5/8 | l.r. - 2.5 YR 6/8 | W | |
| 271 | 08.2109 | L4,B4 | 2B.4b | Rs/C | M | 4S | M | S: we.r. - 10 R 4/4 | S: we.r. - 10 R 4/4 | O: r. - 2.5 YR 5/6 C: g. GLEY 1 N 6 I: r. - 2.5 YR 5/6 | W | 16.1 28 |
| 272 | 08.261 | K19,b2 | 2B.4b | Rs/C | M | 4B | M | S: r. - 2.5 YR 5/8 | S: r. - 2.5 YR 5/8 | O: r. - 2.5 YR 5/6 C: r.g. - 5 YR 5/2 I: r. - 2.5 YR 5/6 | W | 16.1 |
| 273 | 08.1604 | L3,B2 | 2B.4b | P/C | M | 1 | M | r. - 2.5 YR 5/6 | r. - 2.5 YR 5/6 | O: r. - 2.5 YR 5/6 C: d.g. GLEY 1 N 4 I: r. - 2.5 YR 5/6 | W | |

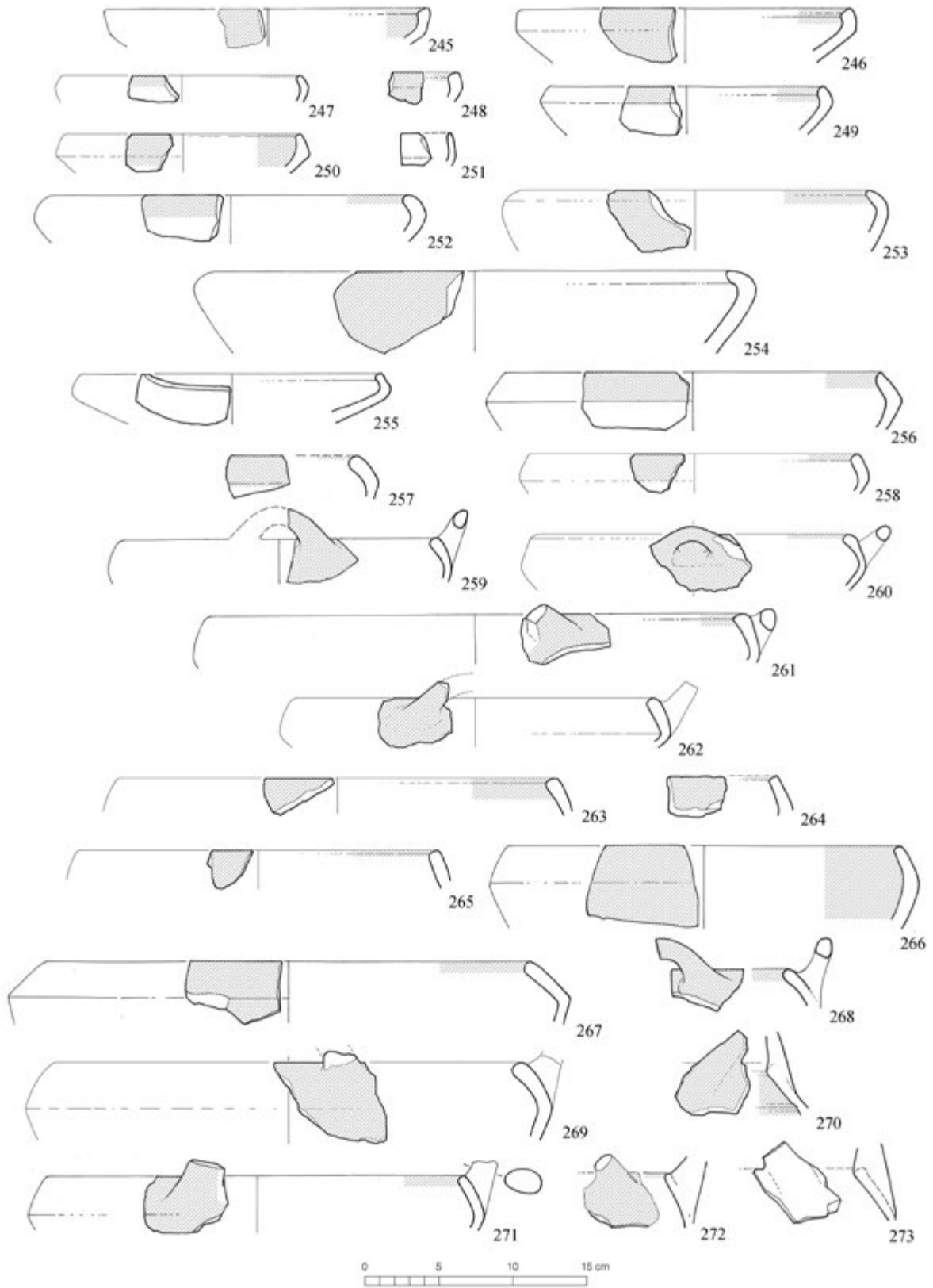


Fig. 11 – Pottery from Uşaklı Höyük.

Figure 12 – Type 2

| n. | UKn. | Area | Type | W/Cl | E | ST | Fa | Colour (out.) | Colour (in.) | Colour (sect.) | T | Pl. |
|-----|---------|----------|--------|--------|----|-----|----|---|---|---|---|--------------------|
| 274 | 09.87 | H18,a4 | 2B.5a | Bb/F | F | 2P | M | l.br. - 7.5 YR 6/4 | l.br. - 7.5 YR 6/4 | O: l.br. - 7.5 YR 6/4 C: y.r. - 5 YR 5/8 I: l.br. - 7.5 YR 6/4 | W | |
| 275 | 09.789 | H15,d1 | 2B.5a | Pt/C | MF | 4Bo | M | P: br. - 7.5 YR 4/2 S: v.p.br. - 10 YR 8/3 | P: br. - 7.5 YR 4/2 S: v.p.br. - 10 YR 8/3 | O: l.br. - 7.5 YR 6/4 C: r.y. - 7.5 YR 6/6 I: l.br. - 7.5 YR 6/4 | W | 23.1 23.3 30 |
| 276 | 12.113 | L9,B3 | 2B.5a | P/C | M | 1 | M | br. - 7.5 YR 5/4 | br. - 7.5 YR 5/4 | br. - 7.5 YR 5/4 | W | |
| 277 | 12.82 | L9,B2 | 2B.5a | Rs/C | M | 4S | M | S: r. - 10 R 5/8 | S: r. - 10 R 5/8 | y.r. - 5 YR 5/6 | W | |
| 278 | 10.23 | L7,B2 | 2B.5a | Rs/C | MF | 4B | M | S: r. - 10 R 5/6; | S: l.r. - 10 R 6/6, pi. - 7.5 YR 7/4 | O: r.y. - 7.5 YR 6/6 C: g. - 7.5 YR 5/1 I: r.y. - 7.5 YR 6/6 | W | |
| 279 | 12.220 | L9,B4 | 2B.5b | Ys/F | F | 4Bo | M | S: r.y. - 5 YR 7/6 | S: r.y. - 5 YR 7/6 | l.r. - 2.5 YR 6/8 | W | |
| 280 | 12.49 | L9,B2 | 2B.5b | Bb/F | MF | 3B | M | Ss: r.y. - 5 YR 6/6 | r.y. - 5 YR 6/6 | r.y. - 5 YR 6/6 | W | |
| 281 | 12.1184 | L11,B5 | 2B.5b | Rs/C | MF | 4S | M | S: r. - 10 R 5/6 | S: p.r. - 10 R 7/4 | r. - 10 R 5/8 | W | |
| 282 | 08.425 | Gen. | 2B.5c | Rs/C | F | 4S | M | S: we.r. - 10 R 4/3 | r.br. - 5 YR 5/4 | O: r.br. - 5 YR 5/4 C: d.g. GLEY 1 N 4 I: r.br. - 5 YR 5/4 | W | |
| 283 | 12.219 | L9,B4 | 2B.5b | Ys/C | M | 4Bo | M | S: y. - 10 YR 8/6 | S: y. - 10 YR 8/6 | r.y. - 5 YR 7/6 | W | |
| 284 | 12.654 | L9,B7 | 2B.5b | Rs/F | F | 4B | M | S: r.br. - 2.5 YR 4/4 | S: r.br. - 2.5 YR 4/4 | l.br. - 7.5 YR 6/4 | W | |
| 285 | 09.268 | H17,c4 | 2B.6 | P/C | M | 2S | M | l.r. - 2.5 YR 6/6 | l.r. - 2.5 YR 6/6 | O: l.r. - 2.5 YR 6/6 C: r.y. - 5 YR 7/6, g. - 5 YR 6/1 I: l.r. - 2.5 YR 6/6 | W | |
| 286 | 09.19 | H16,a3 | 2B.6 | Cg/C | M | 2So | M | l.r. - 2.5 YR 6/6 | l.r. - 2.5 YR 6/6 | l.r. - 2.5 YR 6/6 | W | 26.7 |
| 287 | 09.1056 | L11,d2 | 2B.6 | Cg/C | MC | 3So | M | Ss: v.p.br. - 10 YR 7/3 | Ss: l.r. - 2.5 YR 6/6 | O: r.br. - 5 YR 5/4 C: g. - 5 YR 5/1 I: r.br. - 5 YR 5/4 | W | 26.7 |
| 288 | 08.483 | G19,d3 | 2B.6 | P/C | M | 4S | M | S: p.r. - 10 R 6/4 | S: p.r. - 10 R 6/4 | r.br. - 5 YR 5/4 | W | |
| 289 | 09.98 | H18,a1 | 2B.7a | Rs/C | MF | 4B | M | S: r. - 10 R 5/6 | S: r. - 10 R 5/6 | br. - 7.5 YR 4/4 | W | |
| 290 | 12.659 | L9,B7 | 2B.7a | Rs/C | M | 4B | M | S: r. - 10 R 5/6 | S: r. - 10 R 5/6 | r.br. - 5 YR 5/4 | W | |
| 291 | 12.229 | L9,B4 | 2B.7a | Rs/C | M | 4S | M | S: r. - 10 R 4/8 | r. - 2.5 YR 5/6 | O: r. - 2.5 YR 5/6 C: d.r.g. - 2.5 YR 3/1 I: r. - 2.5 YR 5/6 | W | |
| 292 | 12.519 | L9,B6 | 2B.7b | Rs/F | MF | 4Bo | M | S: r. - 10 R 4/8 | S: r. - 10 R 4/8 | O: br. - 7.5 YR 5/4 I: l.r. - 10 R 6/6 | W | |
| 293 | 12.430 | L9,B5B | 2B.7c | Rs/C | M | 4B | M | S: r. - 2.5 YR 5/6 | S: r. - 2.5 YR 5/6 | y.r. - 5 YR 5/6 | W | |
| 294 | 12.351 | L9,B5A | 2B.7c | Rs/C | M | 4B | M | S: r. - 10 R 5/6 | S: r. - 10 R 5/6 | O: br. - 7.5 YR 5/4 I: r. - 2.5 YR 5/6 | W | |
| 295 | 12.1288 | L11,B6 | 2B.7c | Rs/C | M | 4Bo | M | S: r. - 10 R 5/8 | r. - 2.5 YR 5/6 | O: we.r. - 2.5 YR 4/2 I: r. - 2.5 YR 5/6 | W | |
| 296 | 12.2122 | L12,B6 | 2B.7c | Rs/C | M | 4S | M | S: r. - 10 R 4/6 | S: r. - 10 R 4/6 | O: r.y. - 5 YR 6/8 C: g. - 5 YR 5/1 I: r.y. - 5 YR 6/8 | W | |
| 297 | 08.773 | F19,a4 | 2B.8 | Rs/C | M | 3B | M | Ss: we.r. - 10 R 5/4 | Ss: we.r. - 10 R 5/4 | O: r.y. - 5 YR 6/6 C: g. - 5 YR 5/1 I: r.y. - 5 YR 6/6 | W | |
| 298 | 09.659 | H14,b4 | 2B.8 | Rs/C | M | 4Bo | M | S: r. - 10 R 4/6 | S: r. - 10 R 4/6 | O: v.p.br. - 10 YR 7/3 C: v.d.g. GLEY 1 N 3 I: v.p.br. - 10 YR 7/3 | W | |
| 299 | 08.2133 | L4,B4 | 2B.8 | Rs/C | M | 4B | M | S: we.r. - 10 R 5/4 | S: we.r. - 10 R 5/4 | O: r. - 2.5 YR 5/6 C: d.g. GLEY 1 N 4 I: r. - 2.5 YR 5/6 | W | |
| 300 | 08.414 | F20,a1 | 2B.8 | P/C | M | 3 | M | Ss: l.r. - 10 R 6/8 | Ss: l.r. - 10 R 6/8 | l.r. - 10 R 6/6 | W | 18.6 |
| 301 | 09.1 | L1,B2 | 2B.9 | Rs/F | F | 4B | M | S: we.r. - 10 R 4/4 | S: we.r. - 10 R 4/4 | O: br. - 7.5 YR 5/3 C: br. - 7.5 YR 5/4, g. - 7.5 YR 5/1 I: br. - 7.5 YR 5/3 | W | 16.1 |
| 302 | 12.1771 | L12,B1/2 | 2B.9 | Rs/C-F | M | 4 | M | S: r. - 10 R 5/6 | S: r. - 10 R 5/6 | s.br. - 7.5 YR 5/8 | W | |
| 303 | 09.886 | E16,a3 | 2B.10 | Rs/C | MF | 4B | M | S: r. - 10 R 5/6 | y.r. - 5 YR 5/6 | y.r. - 5 YR 5/6 | W | |
| 304 | 09.1274 | L2,B2 | 2B.11a | Rs/C | MF | 4S | M | S: we.r. - 10 R 4/4, r.y. - 5 YR 6/6 | pi. - 7.5 YR 7/4 | O: r. - 2.5 YR 5/6 C: r.br. - 5 YR 5/4 I: pi. - 7.5 YR 7/4 | W | 17.6 |
| 305 | 08.368 | F20,b2 | 2B.11b | Rs/C-F | M | 4B | M | S: we.r. - 10 R 4/4 | S: we.r. - 10 R 4/4 | r. - 2.5 YR 5/6 | W | 17.2 |

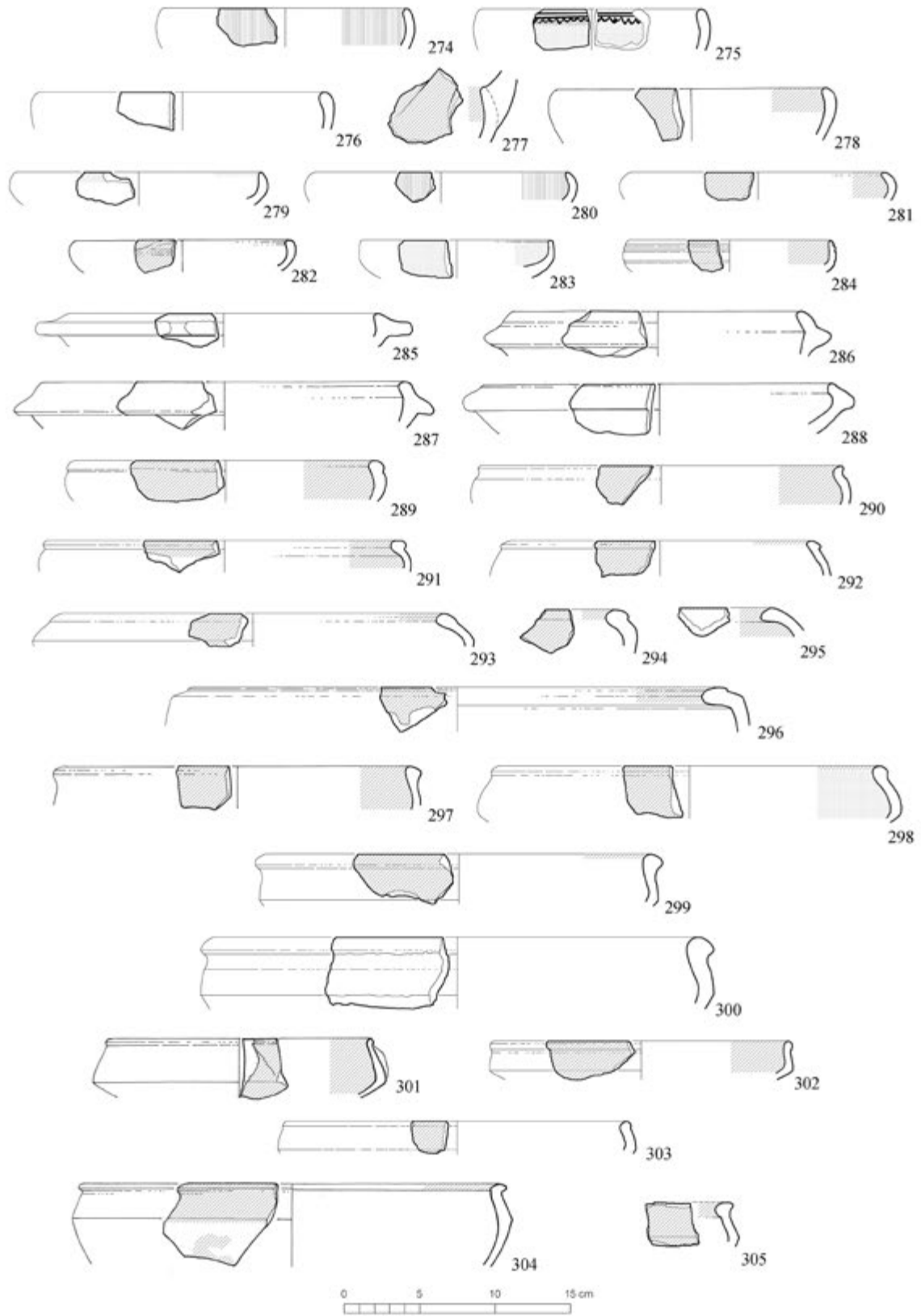


Fig. 12 – Pottery from Uşaklı Höyük.

Figure 13 – Type 2

| n. | UKn. | Area | Type | W/Cl | E | ST | Fa | Colour (out.) | Colour (in.) | Colour (sect.) | T | Pl. |
|-----|---------|---------|--------|------|----|-----|----|--|--|---|---|------------|
| 306 | 12.216 | L9,B4 | 2B.12a | G/C | MC | 3Bo | M | Ss: l.br.g. - 10 YR 6/2 | l.br.g. - 10 YR 6/2 | l.br.g. - 10 YR 6/2 | W | |
| 307 | 12.428 | L9,B5B | 2B.12a | Ys/C | M | 4S | M | S: p.y. - 2.5 Y 7/4 | S: p.y. - 2.5 Y 7/4 | l.r. - 2.5 YR 6/6 | W | |
| 308 | 12.15 | L9,B1 | 2B.12b | Bb/C | M | 2Bo | M | p.br. - 10 YR 6/3 | p.br. - 10 YR 6/3 | p.br. - 10 YR 6/3 | W | |
| 309 | 12.217 | L9,B4 | 2B.12b | Bb/C | MC | 3Bo | M | Ss: r. - 10 R 5/8 | Ss: r. - 10 R 5/8 | we.r. - 2.5YR 4/2 | W | |
| 310 | 09.894 | E16,a1 | 2B.13 | P/C | M | 2S | M | r.br. - 5 YR 5/4 | r.br. - 5 YR 5/4 | O: r.br. - 5 YR 5/4 C: y.r. - 5 YR 5/6 I: r.br. - 5 YR 5/4 | W | 27.1 |
| 311 | 12.435 | L9,B5B | 2B.14 | Bb/C | M | 4B | M | S: p.br. - 10 YR 6/3 | ly.br. - 10 YR 6/4 | O: l.y.br. - 10 YR 6/4 C: g. - 10 YR 5/1 I: l.y.br. - 10 YR 6/4 | W | |
| 312 | 09.287 | H17,d4 | 2B.14 | Cg/C | M | 2So | M | r. - 2.5 YR 5/6 | r. - 2.5YR 5/6 | O: r. - 2.5YR 5/6 C: y.r. - 5 YR 5/6 I: r. - 2.5YR 5/6 | W | 27.1 |
| 313 | 12.53 | L9,B2 | 2B.14 | Rs/C | M | 4S | M | S: r. - 10 R 4/8 | r. - 10 R 5/8 | O: r. - 10 R 5/8 C: we.r. - 2.5 YR 5/2 I: r. - 10 R 5/8 | W | |
| 314 | 08.1978 | L4,B2 | 2B.14 | P/C | M | 3 | M | Ss: r.y. - 5 YR 6/6 | Ss: r.y. - 5 YR 6/6 | s.br. - 7.5 YR 5/6 | W | |
| 315 | 08.1350 | L2,B4 | 2B.15a | P/C | M | 1 | M | br. - 7.5 YR 5/3 | br. - 7.5 YR 5/3 | br. - 7.5 YR 5/3 | W | |
| 316 | 09.889 | E16,a3 | 2B.15a | P/C | M | 2S | M | l.br. - 7.5 YR 6/3 | l.br. - 7.5 YR 6/3 | O: l.br. - 7.5 YR 6/3 C: g. - 7.5 YR 5/1 I: l.br. - 7.5 YR 6/3 | W | |
| 317 | 08.293 | F20,d3 | 2B.15b | Rs/C | M | 3S | M | Ss: l.r.br - 5 YR 6/4 | Ss: l.r.br - 5 YR 6/4 | pi.g. - 5 YR 6/2 | W | |
| 318 | 08.1039 | L2,B1 | 2B.15b | Rs/C | M | 4B | M | S: pi. - 7.5 YR 7/3 | S: pi. - 7.5 YR 7/3 | O: l.r.br - 5 YR 6/3 C: y.r. - 5 YR 5/6 I: l.r.br - 5 YR 6/3 | W | 16,3 28 |
| 319 | 10.167 | L7,B7 | 2B.15b | Rs/C | MF | 4S | M | S: we.r. - 10 R 5/4 | S: l.r.br - 5 YR 6/4 | O: r.br. - 5 YR 5/4 C: br. - 7.5 YR 5/4, g. - 5 YR 5/1 I: r.br. - 5 YR 5/4 | W | |
| 320 | 08.700 | I19,c1 | 2B.15b | Rs/C | M | 4B | M | S: r.y. - 5 YR 6/6 s: l.r. - 2.5 YR 6/6 | S: r.y. - 5 YR 6/6 s: l.r. - 2.5 YR 6/6 | O: l.r. - 2.5 YR 6/6 C: l.r.br - 5 YR 6/4 I: l.r. - 2.5 YR 6/6 | W | |
| 321 | 09.704 | H15,a3 | 2B.15b | Rs/C | MF | 4B | M | S: l.r. - 2.5 YR 6/6 | S: l.r. - 2.5 YR 6/6 | r. - 2.5 YR 5/8 | W | |
| 322 | 08.1939 | L4,B2 | 2B.16 | P/C | M | 1 | M | br. - 7.5 YR 5/3 | br. - 7.5 YR 5/3 | br. - 7.5 YR 5/3 | W | |
| 323 | 09.1144 | L-1,B2B | 2B.16 | P/C | M | 2S | M | r.br. - 5 YR 5/3, br. - 7.5 YR 5/4 | r.br. - 5 YR 5/3, br. - 7.5 YR 5/4 | O: br. - 7.5 YR 5/4 C: g. - 7.5 YR 5/1 I: br. - 7.5 YR 5/4 | W | |
| 324 | 08.1269 | L2,B3 | 2B.17 | P/C | M | 1 | M | br. - 7.5 YR 5/4 | br. - 7.5 YR 5/4 | br. - 7.5 YR 5/4 | W | 18.6 |
| 325 | 08.1351 | L2,B4 | 2B.17 | P/C | MF | 3 | M | Ss: g. GLEY 1 N 5 | r.br. - 5 YR 5/4 | r.br. - 5 YR 5/4 | W | |

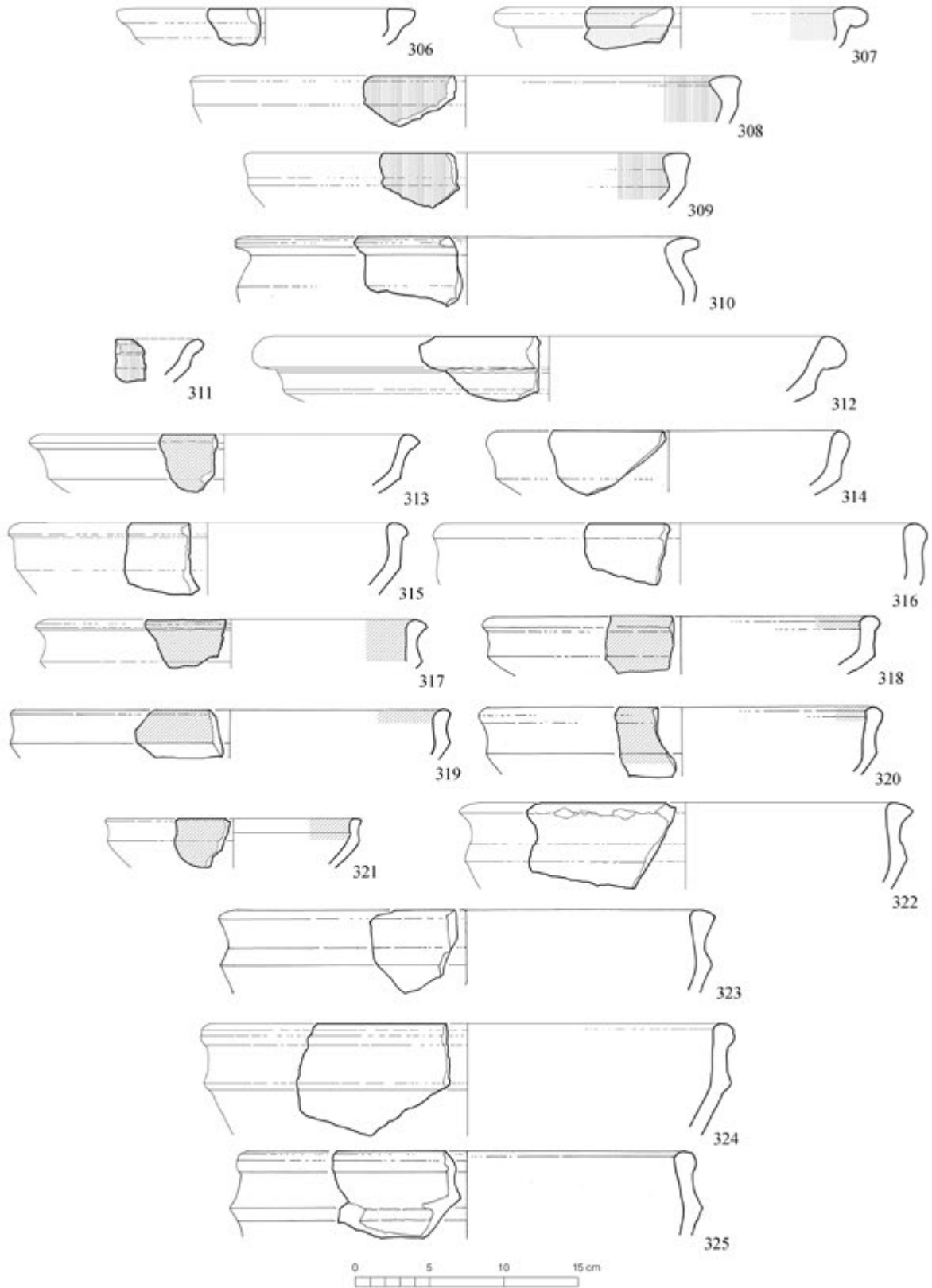


Fig. 13 – Pottery from Uşaklı Höyük.

Figure 14 – Type 2

| n. | UKn. | Area | Type | W/Cl | E | ST | Fa | Colour (out.) | Colour (in.) | Colour (sect.) | T | Pl. |
|-----|---------|--------|-------|------|---|----|----|------------------------|------------------------|--|---|------|
| 326 | 08.810 | F19,b2 | 2B.18 | P/C | M | 2S | M | d.r.g. - 5 YR 4/2 | d.r.g. - 5 YR 4/2 | d.r.g. - 5 YR 4/2 | W | |
| 327 | 08.1362 | L2,B4 | 2B.18 | P/C | M | 2S | M | r.br. - 5 YR 5/4 | r.br. - 5 YR 5/4 | O: r.br. - 5 YR 5/4 C: br. - 7.5 YR 5/2 I: r.br. - 5 YR 5/4 | W | |
| 328 | 08.1368 | L2,B4 | 2B.18 | P/C | M | 2B | M | r.br. - 5 YR 5/4 | y.r. - 5 YR 5/6 | O: r.br. - 5 YR 5/4 C: g. - 10 YR 6/1 I: y.r. - 5 YR 5/6 | W | |
| 329 | 08.796 | F19,b3 | 2B.18 | P/C | F | 3S | M | Ss: l.g. - 5 YR 7/1 | Ss: l.g. - 5 YR 7/1 | r.br. - 5YR 5/4 | W | |
| 330 | 08.769 | F19,b4 | 2B.18 | P/C | M | 2S | M | d.g. - 5 YR 4/1 | d.g. - 5 YR 4/1 | d.g. - 5 YR 4/1 | W | |
| 331 | 09.1010 | L5;c2 | 2B.18 | P/C | M | 2S | M | r.y. - 5 YR 6/6 | r.y. - 5 YR 6/6 | O: r.y. - 5 YR 6/6 C: r. - 2.5 YR 5/8 I: r.y. - 5 YR 6/6 | W | 22.2 |
| 332 | 08.385 | F20,b1 | 2B.18 | P/C | M | 2S | M | l.r. - 10 R 6/6 | l.r. - 10 R 6/6 | l.r. - 10 R 6/6 | W | |
| 333 | 08.311 | F20,c4 | 2B.18 | P/C | F | 3 | M | Ss: l.r.br. - 5 YR 6/4 | Ss: l.r.br. - 5 YR 6/4 | O: y.r. - 5 YR 5/8 C: g. - 5 YR 5/1 I: y.r. - 5 YR 5/8 | W | |
| 334 | 08.436 | G19,a4 | 2B.18 | P/C | M | 3 | M | Ss: pi. 5 YR 7/3 | Ss: pi. 5 YR 7/3 | O: l.r. - 2.5 YR 6/6 C: r.g. - 5 YR 5/2 I: l.r. - 2.5 YR 6/6 | W | 18.6 |
| 335 | 08.1007 | L1,B5 | 2B.18 | P/C | M | 2S | M | r.br. - 5 YR 5/4 | r.br. - 5 YR 5/4 | O: r.br. - 5 YR 5/4 C: l.br.g. - 10 YR 6/2 I: r.br. - 5 YR 5/4 | W | |

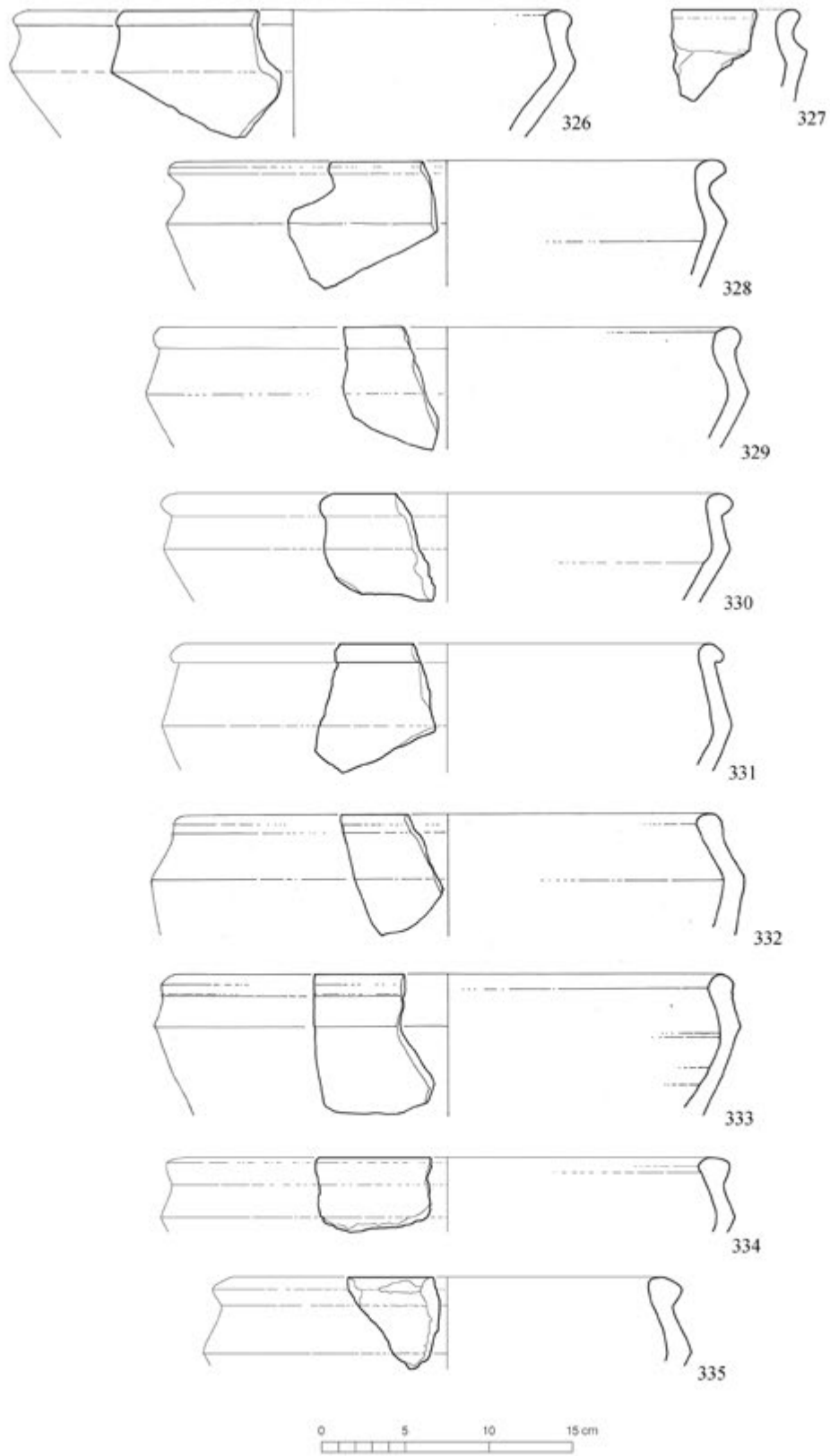


Fig. 14 – Pottery from Uşaklı Höyük.

Figure 15 – Type 2

| n. | UKn. | Area | Type | W/Cl | E | ST | Fa | Colour (out.) | Colour (in.) | Colour (sect.) | T | Pl. |
|-----|---------|--------|-------|------|----|-----|----|------------------------|------------------------|--|---|------|
| 336 | 12.432 | L9,B5B | 2C.1b | Rs/C | M | 4S | M | S: r. - 10 R 5/6 | l.r. - 2.5 YR 6/6 | O: l.r. - 2.5 YR 6/6 C: r.g. - 2.5 YR 5/1 I: l.r. - 2.5 YR 6/6 | W | |
| 337 | 08.915 | L1,B3 | 2C.1b | P/C | M | 2S | M | l.r. - 10 R 6/6 | l.r. - 10 R 6/6 | O: l.r. - 10 R 6/6 C: g. GLEY 1 N 5 I: l.r. - 10 R 6/6 | W | 21.2 |
| 338 | 12.562 | L9,B6 | 2C.1a | Ys/C | M | 4S | M | S: v.p.br. - 10 YR 7/3 | S: pi. - 7.5 YR 7/4 | l.br. - 7.5 YR 6/3 | W | |
| 339 | 12.233 | L9,B4 | 2C.1a | Ys/C | MC | 4S | M | S: v.p.br. - 10 YR 8/4 | S: v.p.br. - 10 YR 8/4 | r.y. - 5 YR 7/6 | W | |
| 340 | 08.1289 | L2,B3 | 2C.2 | Rs/C | M | 4B | M | S: r. - 10 R 5/6 | S: r. - 10 R 5/6 | O: r. - 2.5 YR 5/6 C: d.g. GLEY 1 N 4 I: r. - 2.5 YR 5/6 | W | 17.1 |
| 341 | 09.2 | L1,B2 | 2C.2 | Rs/C | M | 4B | M | S: we.r. - 10 R 4/4 | S: g. - 7.5 YR 5/1 | O: br. - 7.5 YR 5/3 C: d.g. - 10 YR 4/1 I: br. - 7.5 YR 5/3 | W | 16.1 |
| 342 | 10.218 | Gen. | 2C.2 | Rs/C | M | 4S | M | S: r.br. - 2.5 YR 5/4 | S: r.br. - 2.5 YR 5/4 | O: p.r. - 2.5 YR 6/2 C: br. - 7.5 YR 5/2 I: p.r. - 2.5 YR 6/2 | W | 16.1 |
| 343 | 08.1626 | L3,B2 | 2C.2 | Rs/C | M | 4S | M | S: we.r. - 10 R 5/4 | S: we.r. - 10 R 5/4 | O: r. - 2.5 YR 5/6 C: d.g. GLEY 1 N 4 I: r. - 2.5 YR 5/6 | W | 16.1 |
| 344 | 12.557 | L9,B6 | 5A | Ys/C | M | 4Bo | M | S: v.p.br. - 10 YR 7/3 | S: v.p.br. - 10 YR 7/3 | O: l.br. - 7.5 YR 6/3 C: g. - 10 YR 6/1 I: l.br. - 7.5 YR 6/3 | W | |

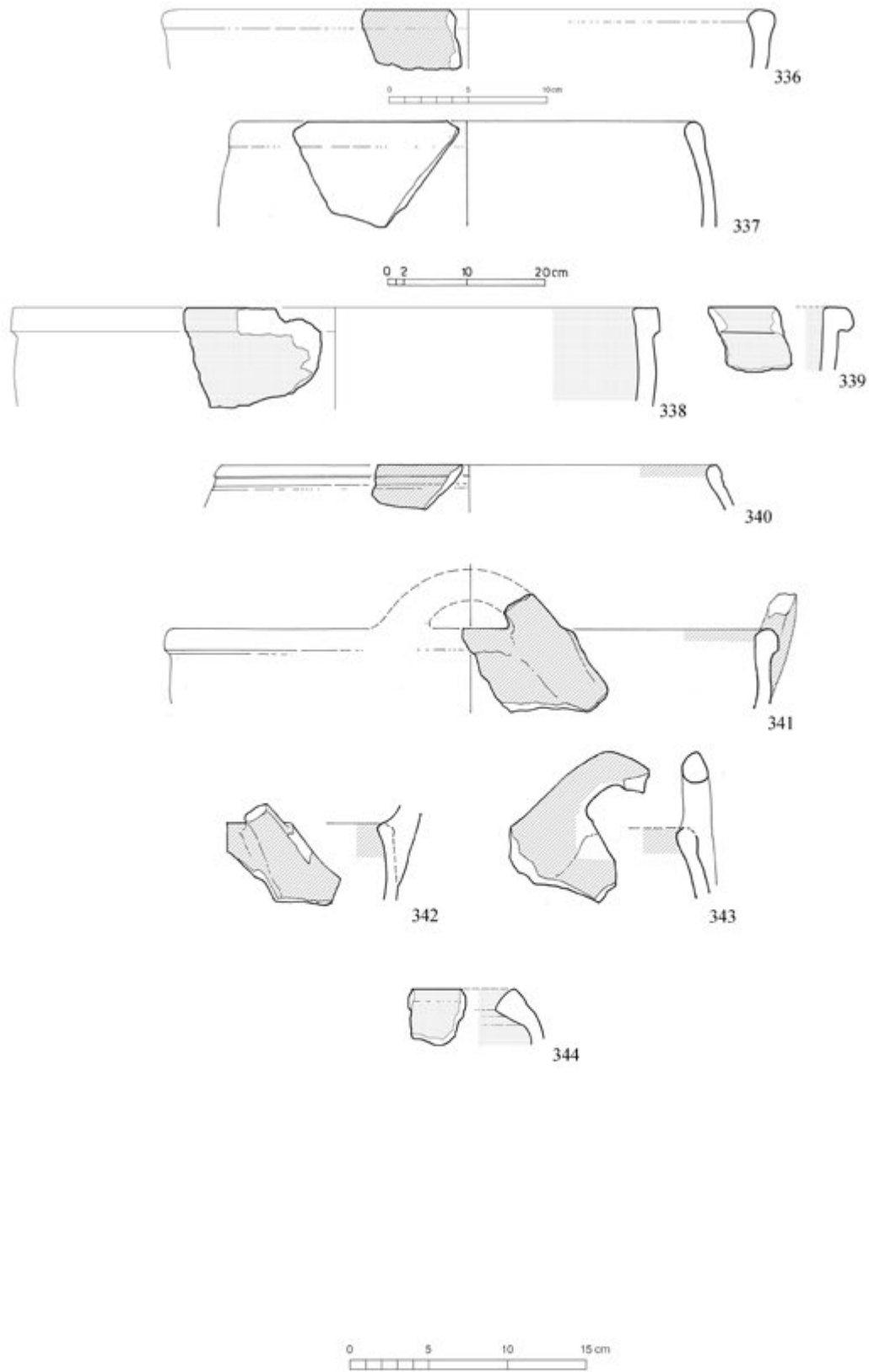


Fig. 15 – Pottery from Uşaklı Höyük.

Figure 16 – Type 3

| n. | UKn. | Area | Type | W/Cl | E | ST | Fa | Colour (out.) | Colour (in.) | Colour (sect.) | T | Pl. |
|-----|---------|----------|------|------|----|-------|----|---|---|--|---|------------|
| 345 | 12.1708 | L10,B9 | 3A.1 | Rs/C | MF | 4Bv | M | S: r.br. - 5 YR 5/4 | S: r.br. - 5 YR 5/4 | O: r. - 2.5 YR 5/6 C: r.y. - 5 YR 6/6 I: r. - 2.5 YR 5/6 | W | |
| 346 | 08.1236 | L2,B3 | 3A.1 | Rs/F | F | 4B | M | S: r. - 10 R 5/6 | S: r. - 10 R 5/6 | y.r. - 5 YR 5/6 | W | 17.1 |
| 347 | 09.887 | E16,a3 | 3A.1 | Rs/F | M | 4Bo | M | S: r. - 10 R 5/6 | S: r. - 10 R 5/6 | O: g. - 5 YR 5/1 I: y.r. - 5 YR 5/6 | W | |
| 348 | 12.520 | L9,B6 | 3A.1 | Rs/F | MF | 4S | M | S: r. - 2.5 YR 4/6 | S: r. - 2.5 YR 4/6 | O: r. - 2.5 YR 5/6 I: l.r.br - 5 YR 6/4 | W | |
| 349 | 12.431 | L9,B5B | 3A.1 | Rs/F | MF | 4S | M | S: r. - 10 R 5/6 | br. - 7.5 YR 5/4 | br. - 7.5 YR 5/4 | W | |
| 350 | 12.232 | L9,B4 | 3A.1 | Rs/F | M | 4 | M | S: we.r. - 10 R 5/4 | r. - 2.5 YR 5/6 | O: r. - 2.5 YR 5/6 C: d.r.g. - 10 R 3/1 I: r. - 2.5 YR 5/6 | W | |
| 351 | 08.1254 | L2,B3 | 3A.1 | Rs/C | M | 4B | M | S: r.y. - 5 YR 6/6 | S: r.y. - 5 YR 6/6 | O: l.r.br - 5 YR 6/4 C: l.gr.g. GLEY 1 10 Y 7/1 I: l.r.br - 5 YR 6/4 | W | |
| 352 | 08.1170 | L2,B3 | 3A.1 | P/C | M | 1 | M | r.y. - 5 YR 6/6 | r.y. - 5 YR 6/6 | r.y. - 5 YR 6/6 | W | |
| 353 | 12.660 | L9,B7 | 3A.1 | Rs/F | MF | 4B | M | S: r. - 10 R 4/6 | S: r. - 10 R 4/6 | O: l.r.br - 5 YR 6/4 C: y.r. - 5 YR 5/6 I: l.r.br - 5 YR 6/4 | W | |
| 354 | 12.1777 | L12,B1/2 | 3A.1 | Rs/F | F | 4P | M | S: r. - 10 R 4/8 | S: r. - 10 R 4/8 | r.y. - 5 YR 6/6 | W | |
| 355 | 08.1655 | L3,B3 | 3A.2 | P/F | MF | 2S | M | lg. - 5 YR 7/1 | lg. - 5 YR 7/1 | lg. - 7.5 YR 7/1 | W | |
| 356 | 12.352 | L9,B5A | 3A.2 | P/C | M | 2S | M | r. - 2.5 YR 5/6 | r. - 2.5 YR 5/6 | r. - 2.5 YR 5/6 | W | |
| 357 | 08.2026 | L4,B3 | 3A.2 | Rs/F | F | 4S | M | S: l.r. - 2.5 YR 6/6 | S: l.r. - 2.5 YR 6/6 | y.r. - 5 YR 5/6 | W | 17.1 |
| 358 | 08.44 | J19 | 3A.3 | K/K | M | 1 | M | r. - 2.5 YR 5/6 | r. - 2.5 YR 5/6 | r. - 2.5 YR 5/6 | W | |
| 359 | 08.822 | F19,a2 | ZB | Rs/F | MF | 4Bo+v | M | S: r. - 10 R 4/8 | S: r. - 10 R 4/8 | O: d.g. GLEY 1 N 4 I: l.r.br - 5 YR 6/4 | W | |
| 360 | 08.569 | H19,a2 | ZB | Ys/F | M | 4P | M | S: r.y. - 7.5 YR 7/6 | S: r.y. - 7.5 YR 7/6 | r.y. - 7.5 YR 7/6 | W | 26.2 30 |
| 361 | 10.87 | L5,B5 | 3A.4 | Pt/C | M | 3S | M | P: d.g. - 7.5 YR 4/1 Ss: l.br. - 7.5 YR 6/4 | P: d.g. - 7.5 YR 4/1 s: l.br. - 7.5 YR 6/4 | l.br. - 7.5 YR 6/4 | W | |
| 362 | 12.1339 | L11,B6 | 3A.4 | Pt/F | MF | 4P | M | P: v.d.g. - 10 YR 3/1 S: v.p.br. - 10 YR 7/4 | S: v.p.br. - 10 YR 7/4 | r.y. - 5 YR 6/6 | W | |
| 363 | 12.356 | L9,B5A | 3A.5 | Rs/F | MF | 4S | M | S: r. - 10 R 4/6 | S: r. - 10 R 4/6 | l.r. - 2.5 YR 6/6 | W | 27.8 |

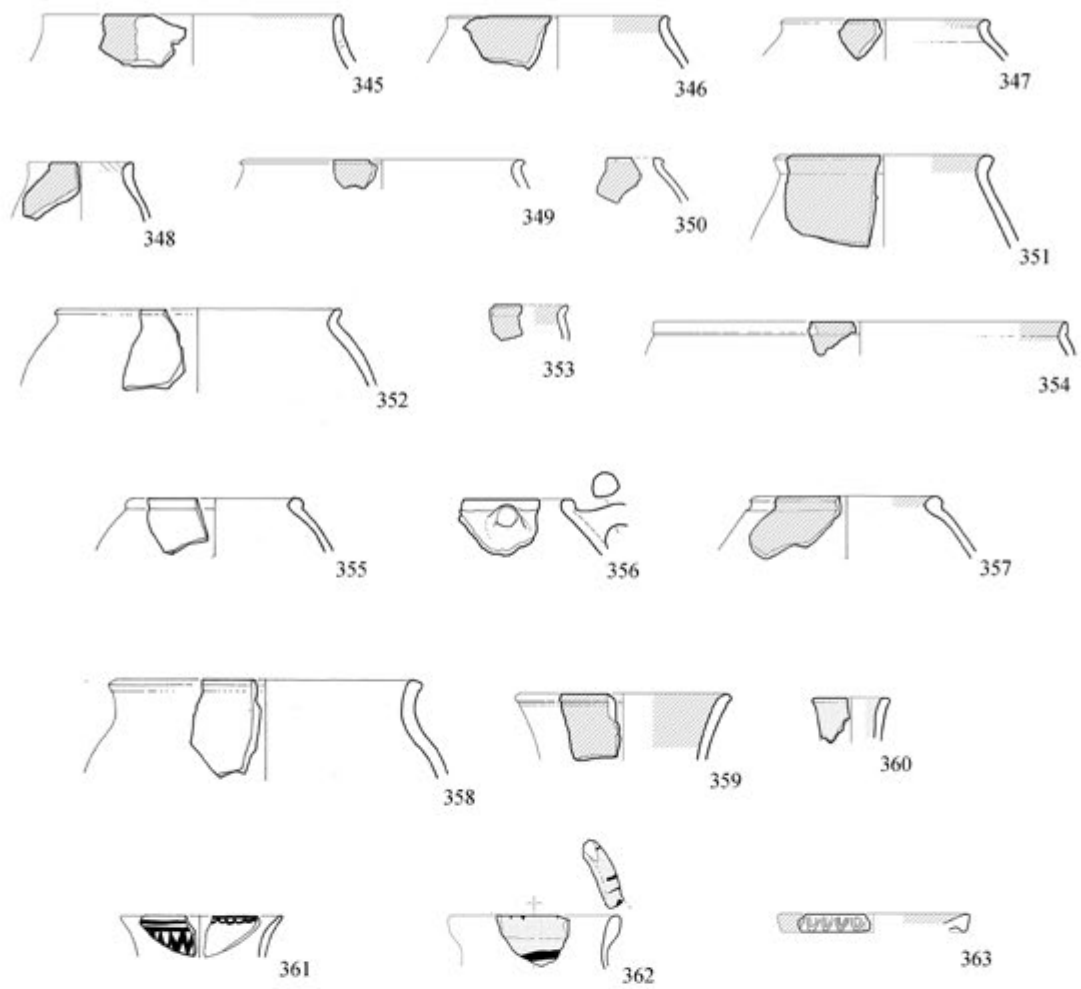


Fig. 16 – Pottery from Uşaklı Höyük.

Figure 17 – Type 5

| n. | UKn. | Area | Type | W/Cl | E | ST | Fa | Colour (out.) | Colour (in.) | Colour (sect.) | T | Pl. |
|-----|---------|--------|-------|------|----|-----|----|---|---------------------|--|----|------|
| 364 | 12.174 | L9,B3 | 5A.1 | K/K | MC | 3 | M | Ss: br. - 7.5 YR 4/3 | br. - 7.5 YR 4/3 | br. - 7.5 YR 4/3 | W | |
| 365 | 08.1931 | L4,B2 | 5A.1 | Rs/C | C | 4 | M | S: l.r. - 2.5 YR 6/8 | l.r. - 2.5 YR 6/6 | O: l.r. - 2.5 YR 6/6 C: v.d.g. GLEY 1 N 3 I: l.r. - 2.5 YR 6/6 | HW | 15.9 |
| 366 | 12.175 | L9,B3 | 5A.2 | K/K | MC | 1 | M | r.br. - 5 YR 4/4 | r.br. - 5 YR 4/4 | r.br. - 5 YR 4/4 | W | |
| 367 | 08.906 | L1,B2 | 5A.2 | K/K | M | 1 | M | br. - 7.5 YR 5/4 | br. - 7.5 YR 5/4 | O: br. - 7.5 YR 5/4 C: d.g. - 5 YR 4/1 I: br. - 7.5 YR 5/4 | W | |
| 368 | 08.911 | L1,B2 | 5A.2 | P/C | M | 2S | M | r.br. - 2.5 YR 5/4 | r.br. - 2.5 YR 5/4 | O: r.br. - 2.5 YR 5/4 C: g. GLEY 1 N 5 I: r.br. - 2.5 YR 5/4 | W | |
| 369 | 09.963 | L9,d4 | 5A.2 | Pt/C | M | 2Bo | M | P: we.r. - 10 R 4/4 s: r. - 2.5 YR 5/6 | p.r. - 10 R 6/3 | O: r. - 2.5 YR 5/6 C: r.y. - 5 YR 6/6 I: p.r. - 10 R 6/3 | W | 25.2 |
| 370 | 09.422 | G16,c1 | 5A.3 | P/C | M | 2S | M | l.r.br - 5 YR 6/4 | l.r.br - 5 YR 6/4 | O: l.r.br - 5 YR 6/4 C: br. - 7.5 YR 5/4 I: l.r.br - 5 YR 6/4 | W | |
| 371 | 09.901 | E16,c3 | 5A.3 | K/K | M | 2S | M | pi. - 5 YR 7/4 | pi. - 5 YR 7/4 | O: pi. - 5 YR 7/4 C: y.r. - 5 YR 5/6 I: pi. - 5 YR 7/4 | W | |
| 372 | 09.184 | G15,a4 | 5A.3 | K/K | M | 2So | M | we.r. - 2.5 YR 5/2 | we.r. - 2.5 YR 5/2 | O: we.r. - 2.5 YR 5/2 C: r.g. - 2.5 YR 5/1 I: we.r. - 2.5 YR 5/2 | W | 26.5 |
| 373 | 08.1905 | L4,B1 | 5A.3 | Rs/C | M | 4S | M | S: we.r. - 10 R 5/3 | l.r. - 10 R 6/8 | O: l.r. - 10 R 6/8 C: l.br. - 7.5 YR 6/3 I: l.r. - 10 R 6/8 | W | |
| 374 | 08.767 | F19,b4 | 5A.4 | K/K | M | 1 | M | r. - 10 R 5/6 | r. - 10 R 5/6 | O: r. - 10 R 5/6 C: gr.g. GLEY 1 10 Y 5/1 I: r. - 10 R 5/6 | W | |
| 375 | 08.551 | Gen. | 5A.4 | K/K | M | 2S | M | l.r. - 2.5 YR 6/8 | l.r. - 2.5 YR 6/8 | l.r. - 2.5 YR 6/8 | W | |
| 376 | 12.481 | L9,B5B | 5A.5 | K/K | M | 3 | M | Ss: y.r. - 5 YR 5/6 | Ss: y.r. - 5 YR 5/6 | O: y.r. - 5 YR 5/8 C: y.r. - 5 YR 5/6 I: y.r. - 5 YR 5/8 | W | |
| 377 | 09.17 | H16.a3 | 5A.5 | P/C | MF | 2So | M | l.r.br - 5 YR 6/3 | l.r.br - 5 YR 6/3 | O: l.r.br - 5 YR 6/3 C: d.g. - 5 YR 4/1 I: l.r.br - 5 YR 6/3 | W | 22.4 |
| 378 | 09.600 | H13,d4 | 5A.6 | K/K | MF | 3S | M | Ss: p.br. - 10 YR 6/3 | br. - 10 YR 5/3 | O: br. - 10 YR 5/3 C: d.g. - 10 YR 4/1 I: br. - 10 YR 5/3 | W | |
| 379 | 12.16 | L9,B1 | 5A.6 | K/K | M | 3 | M | Ss: r. - 2.5 YR 5/6 | Ss: r. - 2.5 YR 5/6 | d.r.g. - 2.5 YR 4/1 | W | |
| 380 | 08.1234 | L2,B3 | 5A.6 | Rs/C | M | 4B | M | S: pi - 5 YR 7/4 | S: pi - 5 YR 7/4 | r.br. - 5 YR 5/4 | W | |
| 381 | 08.337 | F20,b1 | 5A.11 | P/C | M | 1 | M | r.y. - 5 YR 6/6 | r.y. - 5 YR 6/6 | r.y. - 5 YR 6/6 | W | |
| 382 | 08.426 | Gen. | 5A.7 | K/K | F | 2S | M | r.y. - 5 YR 7/6 | r.y. - 5 YR 7/6 | O: r.y. - 5 YR 7/6 C: d.g. GLEY 1 N 4 I: r.y. - 5 YR 7/6 | W | |

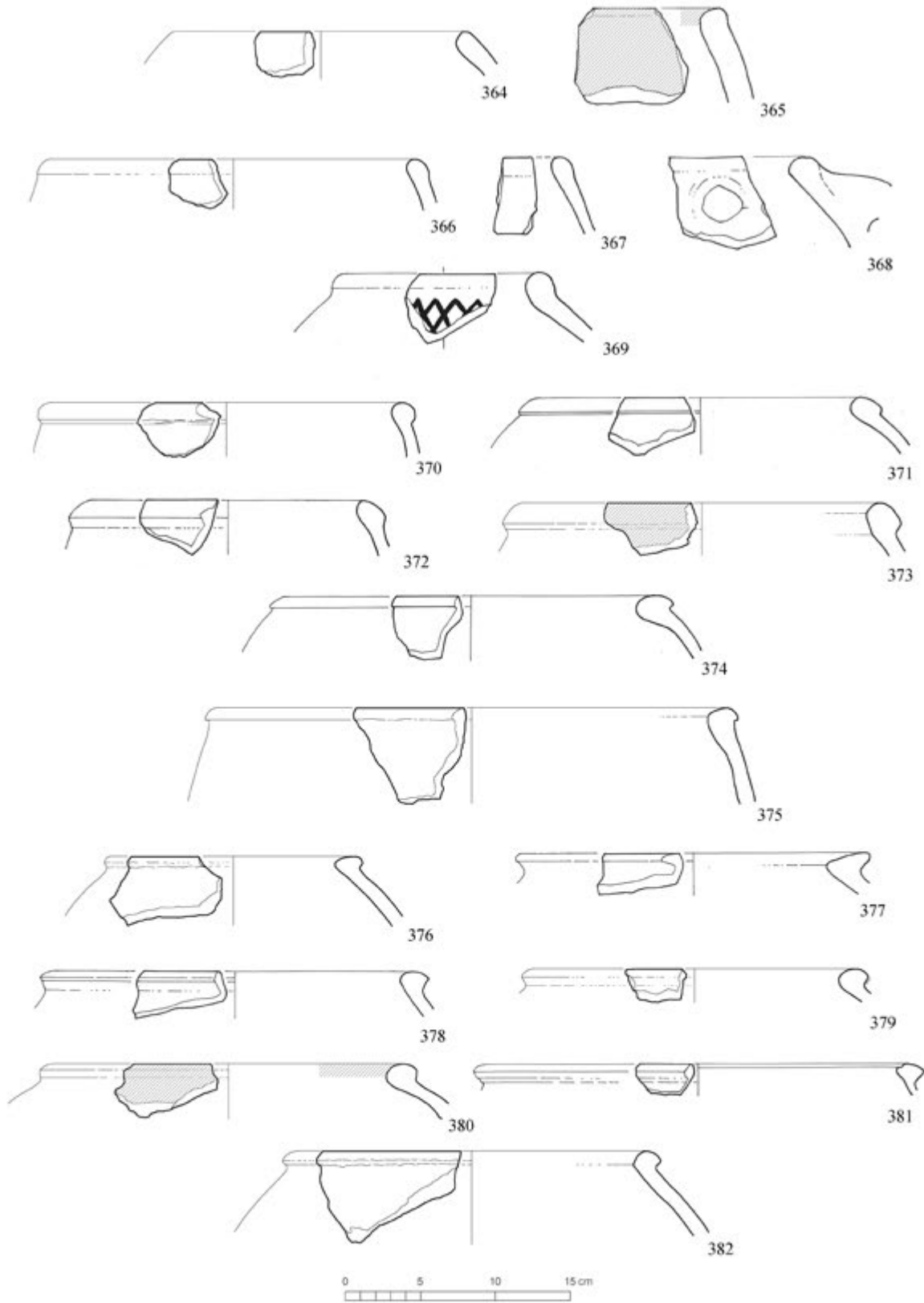


Fig. 17 – Pottery from Uşaklı Höyük.

Figure 18 – Type 5

| n. | UKn. | Area | Type | W/Cl | E | ST | Fa | Colour (out.) | Colour (in.) | Colour (sect.) | T | Pl. |
|-----|---------|--------|-------|------|----|------|----|----------------------------------|------------------------|---|---|------|
| 383 | 08.772 | F19,b4 | 5A.7 | K/K | M | 3B | M | Ss: r.br. - 2.5 YR 5/3 | r.br. - 2.5 YR 5/3 | O: r.br. - 2.5 YR 5/3 C: r. - 10 R 5/8 I: r.br. - 2.5 YR 5/3 | W | |
| 384 | 08.1056 | L2,B2 | 5A.7 | K/K | M | 3S | M | Ss: r.br. - 5 YR 5/4 | r.br. - 5 YR 5/4 | r.br. - 5 YR 5/4 | W | |
| 385 | 08.618 | H19,b1 | 5A.8a | K/K | MF | 1 | M | d.r.g. - 2.5 YR 3/1 | d.r.g. - 2.5 YR 3/1 | d.r.g. - 2.5 YR 3/1 | W | 21.1 |
| 386 | 08.1579 | L3,B2 | 5A.8a | K/K | M | 1 | M | b. - 5 YR 2.5/1, r. - 2.5 YR 5/6 | r. - 2.5 YR 5/6 | O: r. - 2.5 YR 5/6 C: g. - GLEY 1 N 5 I: r. - 2.5 YR 5/6 | W | 21.1 |
| 387 | 08.2105 | L4,B4 | 5A.8b | Rs/C | F | 4P | M | S: v.p.br. - 10 YR 7/4 | S: v.p.br. - 10 YR 7/4 | r.br. - 5 YR 5/4 | W | 16.3 |
| 388 | 08.1224 | L2,B3 | 5A.8b | Rs/C | M | 4+4B | M | S: pi. - 10 R 8/4, r. - 10 R 5/8 | S: pi. - 10 R 8/4 | O: r.br. - 5 YR 5/4 C: br. - 7.5 YR 5/2 I: r.br. - 5 YR 5/4 | W | 16.3 |
| 389 | 08.413 | F20,a1 | 5A.8b | Rs/C | M | 4B | M | S: r. - 10 R 5/8 | S: r. - 10 R 5/8 | O: l.r. - 2.5 YR 7/8 C: r.br. - 5 YR 5/3 I: l.r. - 2.5 YR 7/8 | W | |
| 390 | 08.1995 | L4,B2 | 5A.9 | K/K | M | 1 | M | r.g. - 5 YR 5/2 | r.br. - 5 YR 5/4 | O: r.g. - 5 YR 5/2 I: r.br. - 5 YR 5/4 | W | 33 |
| 391 | 08.914 | L1,B3 | 5A.9 | P/C | M | 3 | M | Ss: l.g. - 7.5 YR 7/1 | l.g. - 7.5 YR 7/1 | l.g. - 7.5 YR 7/1 | W | |
| 392 | 09.1035 | L11,b4 | 5A.10 | P/C | MF | 2So | M | l.br. - 7.5 YR 6/3 | l.br. - 7.5 YR 6/3 | O: l.br. - 7.5 YR 6/3 C: br. - 7.5 YR 5/3, g. - 7.5 YR 6/1 I: l.br. - 7.5 YR 6/3 | W | |
| 393 | 09.599 | H13,d4 | 5A.10 | K/K | M | 2So | M | r. - 2.5 YR 5/6 | r. - 2.5 YR 5/6 | O: r. - 2.5 YR 5/6 C: r.g. - 5 YR 5/2 I: r. - 2.5 YR 5/6 | W | |
| 394 | 08.327 | F20,c2 | 5A.6 | P/C | M | 1 | M | l.br. - 7.5 YR 6/4 | l.br. - 7.5 YR 6/4 | O: l.br. - 7.5 YR 6/4 C: r.g. - 5 YR 5/2 I: l.br. - 7.5 YR 6/4 | W | |
| 395 | 12.2061 | L12,B5 | 5A.11 | Bb/C | M | 3S | M | Ss: r. - 2.5 YR 5/8 | Ss: r. - 2.5 YR 5/8 | O: r.br. - 5 YR 5/4 C: r.g. - 2.5 YR 5/1 I: r.br. - 5 YR 5/4 | W | |
| 396 | 08.775 | F19,a4 | 5A.12 | K/K | M | 1 | M | r.br. - 2.5 YR 5/3 | r.br. - 2.5 YR 5/3 | r.br. - 2.5 YR 5/3 | W | |
| 397 | 12.55 | L9,B2 | 5A.12 | Rs/C | M | 4S | M | S: r. - 10 R 5/8 | r.y. - 5 YR 6/8 | O: r.y. - 5 YR 6/8 C: g. - 7.5 YR 5/1 I: r.y. - 5 YR 6/8 | W | |

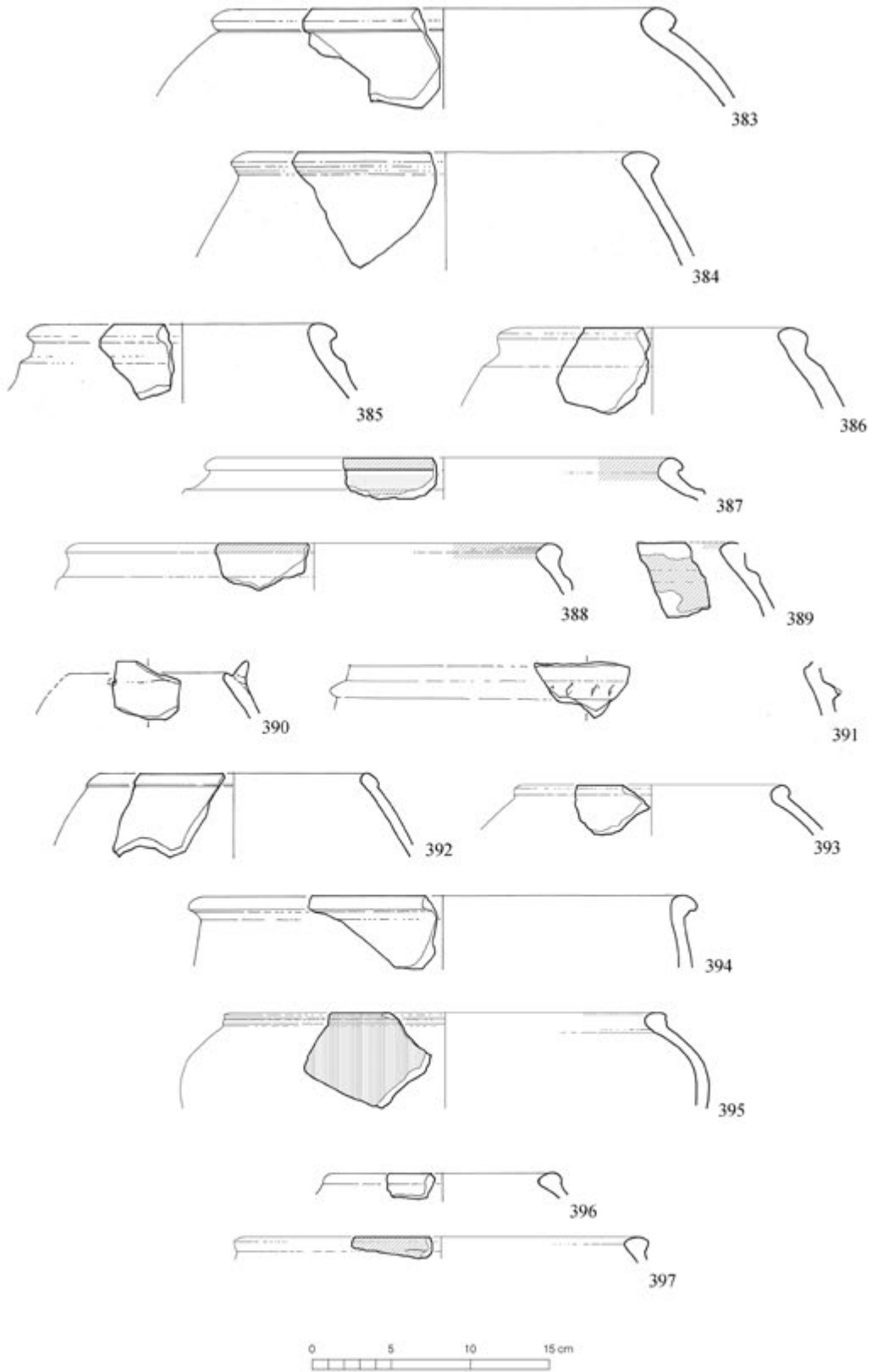


Fig. 18 – Pottery from Uşaklı Höyük.

Figure 19 – Type 6

| n. | UKn. | Area | Type | W/Cl | E | ST | Fa | Colour (out.) | Colour (in.) | Colour (sect.) | T | Pl. |
|-----|---------|--------|-------|------|----|-----|----|--|--|---|---|------|
| 398 | 09.925 | F13,b1 | 6A.1a | K/K | MC | 1 | M | br. - 7.5 YR 4/3 | br. - 7.5 YR 4/3 | br. - 7.5 YR 4/3 | W | 26.5 |
| 399 | 08.566 | H19,a3 | 6A.1a | Pt/C | M | 2B | M | P: we.r. - 10 R 4/4 s: r.y. - 5 YR 6/6 | r.y. - 5 YR 6/6 | r.y. - 5 YR 6/6 | W | 25.2 |
| 400 | 09.839 | L9,a2 | 6A.1a | P/C | MF | 3S | M | Ss: r.y. - 7.5 YR 7/4 | Ss: r.y. - 7.5 YR 7/4 | r. - 2.5 YR 5/6 | W | 22.4 |
| 401 | 08.778 | F19,a4 | 6A.2 | P/C | M | 2S | M | br. - 7.5 YR 5/4 | br. - 7.5 YR 5/4 | br. - 7.5 YR 5/4 | W | |
| 402 | 12.100 | L9,B2 | 6A.3 | K/K | M | 2Bo | M | l.r. - 2.5 YR 6/6 | l.r. - 2.5 YR 6/6 | l.r. - 2.5 YR 6/6 | W | |
| 403 | 12.237 | L9,B4 | 6A.4 | Rs/C | C | 4S | M | S: r.y. - 5 YR 6/6 | S: r.y. - 5 YR 6/6 | l.r. - 2.5 YR 6/6 | W | |
| 404 | 10.9 | L8,B1 | 6A.4 | Bb/C | MF | 2B | M | l.br. - 7.5 YR 6/4 | l.r. - 2.5 YR 7/6 | O: l.br. - 7.5 YR 6/4 I: l.r. - 2.5 YR 7/6 | W | |
| 405 | 08.750 | F19,d4 | 6A.5 | Rs/C | MF | 4S | M | S: r. - 2.5 YR 5/6 | S: r. - 2.5 YR 5/6 | O: r.y. - 5 YR 6/6 C: gr.g.- GLEY 1 10 Y 6/1 I: r.y. - 5 YR 6/6 | W | |
| 406 | 08.1503 | L3,B1 | 6A.5 | P/C | M | 3 | M | Ss: pi. - 5 YR 7/4 | Ss: pi. - 5 YR 7/4 | l.r. - 10 R 6/6 | W | 27.4 |
| 407 | 09.792 | H15,d1 | 6B.1 | K/K | M | 2Bo | M | r.g. - 5 YR 5/2 | r.g. - 5 YR 5/2 | O: r.g. - 5 YR 5/2 C: r.br. - 2.5 YR 4/3 I: r.g. - 5 YR 5/2 | W | |
| 408 | 12.29 | L9,B1 | 6B.1 | K/K | M | 3S | M | Ss: p.br. - 10 YR 6/3 | Ss: p.br. - 10 YR 6/3 | r. - 10 R 5/6 | W | |
| 409 | 12.96 | L9,B2 | 6B.1 | K/K | C | 2S | M | g. - 5 YR 5/1 | g. - 5 YR 5/1 | g. - 5 YR 5/1 | W | |
| 410 | 12.293 | L9,B4 | 6B.1 | K/K | M | 1 | M | r. - 2.5 YR 5/6 | r. - 2.5 YR 5/6 | r. - 2.5 YR 5/6 | W | |
| 411 | 08.19 | J19 | 6B.2 | K/K | M | 1 | M | d.r.g. - 2.5 YR 4/1 | d.r.g. - 2.5 YR 4/1 | d.r.g. - 2.5 YR 4/1 | W | |
| 412 | 12.1910 | L12,B3 | 6B.2 | Br/K | MF | 1 | M | r.br. - 2.5 YR 4/3 | r.br. - 2.5 YR 4/3 | r.br. - 2.5 YR 4/3 | W | |
| 413 | 09.855 | F14,c2 | 6B.3 | Br/K | MF | 1 | M | r.b. - 5 YR 5/4, y.r. - 5 YR 4/6 | r.b. - 5 YR 5/4, y.r. - 5 YR 4/6 | O: r.b. - 5 YR 5/4 C: d.g. - 10 YR 4/1 I: r.b. - 5 YR 5/4 | W | |
| 414 | 09.182 | G17,b1 | 6B.3 | P/C | F | 3Bo | M | Ss: r.y. - 7.5 YR 6/6 | Ss: r.y. - 5 YR 7/6 | r.br. - 5 YR 5/4 | W | |
| 415 | 09.943 | L9,a4 | 6B.3 | Br/K | MF | 2S | M | d.r.g. - 2.5 YR 4/1 | l.r. - 2.5 YR 7/8 | O: d.r.g. - 2.5 YR 4/1 C: l.r. - 2.5 YR 6/8, r.g. - 2.5 YR 5/1 I: l.r. - 2.5 YR 7/8 | W | |
| 416 | 09.878 | F15,c1 | 6B.4 | Cg/C | M | 2S | M | pi. - 5 YR 7/3 | r.y. - 5 YR 7/6 | O: pi. - 5 YR 7/3 C: r.g. - 5 YR 5/2 I: r.y. - 5 YR 7/6 | W | 22.4 |
| 417 | 12.291 | L9,B4 | 6B.4 | K/K | M | 1 | M | d.r.g. - 5 YR 4/2 | r. - 2.5 YR 5/6 | O: d.r.g. - 5 YR 4/2 C: we.r. - 2.5 YR 5/2 I: r. - 2.5 YR 5/6 | W | |
| 418 | 12.99 | L9,B2 | 6B.4 | K/K | M | 3 | M | Ss: py. - 2.5 Y 8/2 | Ss: py. - 2.5 Y 8/2 | g. - 2.5 Y 5/1 | W | |
| 419 | 09.226 | G15,c1 | 6B.4 | Br/K | M | 3So | M | Ss: p.g. - 7.5 YR 6/2 | l.r. - 2.5 YR 6/6 | O: l.r. - 2.5 YR 6/6 C: l.r. - 2.5 YR 6/8 I: l.r. - 2.5 YR 6/6 | W | 22.4 |
| 420 | 09.241 | G15,d3 | 6B.4 | P/C | M | 3So | M | Ss: l.r. - 10 R 6/6 | Ss: l.r. - 10 R 7/6 | l.r. - 2.5 YR 6/8 | W | 22.4 |
| 421 | 12.64 | L9,B2 | 6B.5 | P/C | M | 1 | M | l.r. - 2.5 YR 6/8 | l.r. - 2.5 YR 6/8 | l.r. - 2.5 YR 6/8 | W | |
| 422 | 12.63 | L9,B2 | 6B.5 | K/K | M | 3 | M | Ss: y.r. - 5 YR 5/6 | y.r. - 5 YR 5/6 | O: y.r. - 5 YR 5/6 C: b. - 7.5 YR 2.5/1 I: y.r. - 5 YR 5/6 | W | |
| 423 | 12.97 | L9,B2 | 6B.5 | K/K | MC | 3Bo | M | Ss: r.br. - 5 YR 5/4 | y.r. - 5 YR 5/6 | y.r. - 5 YR 5/6 | W | |
| 424 | 12.860 | L9,B8 | 6B.6 | Pt/C | M | 4S | M | P: r.b. - 2.5 YR 2.5/1 S: r.y. - 5 YR 6/6 | P: r.b. - 2.5 YR 2.5/1 S: r.y. - 5 YR 6/6 | y.r. - 5 YR 5/6 | W | |
| 425 | 12.145 | L9,B3 | 6B.6 | P/C | M | 3S | M | Ss: br. - 7.5 YR 5/4 | br. - 7.5 YR 5/4 | br. - 7.5 YR 5/4 | W | |
| 426 | 12.19 | L9,B1 | 6B.6 | Ys/C | MC | 4Bo | M | S: v.p.br. - 10 YR 7/3 | S: v.p.br. - 10 YR 7/3 | pi. - 7.5 YR 7/4 | W | |
| 427 | 12.18 | L9,B1 | 6B.6 | P/C | MC | 3 | M | Ss: pi. - 5 YR 7/4 | Ss: pi. - 5 YR 7/4 | l.r. - 2.5 YR 6/6 | W | |
| 428 | 12.719 | L9,B7 | 6B.6 | P/C | MC | 3S | M | Ss: pi. - 5 YR 7/4 | l.r.br - 5 YR 6/4 | l.r.br - 5 YR 6/4 | W | |

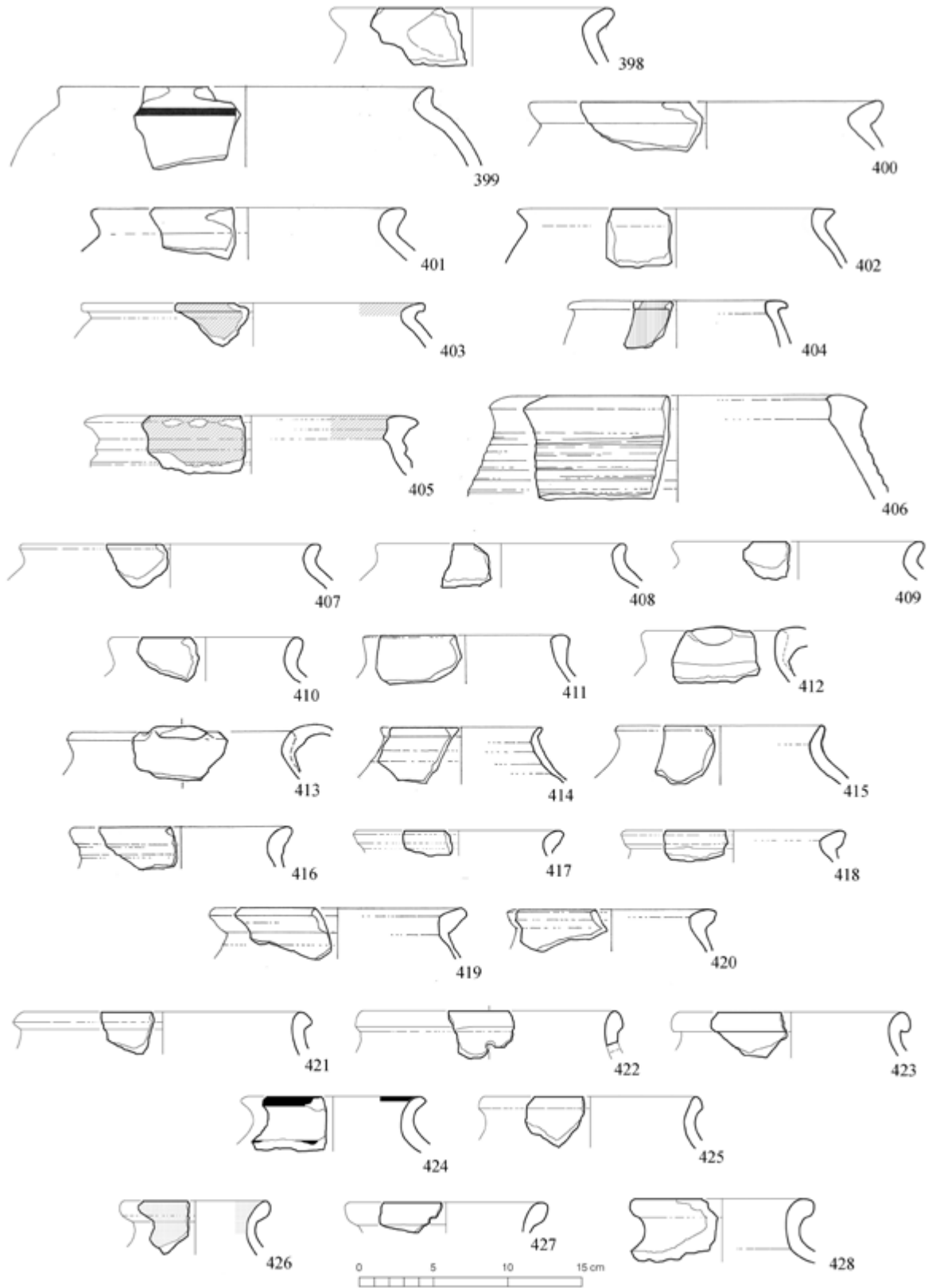


Fig. 19 – Pottery from Uşaklı Höyük.

Figure 20 – Type 6

| n. | UKn. | Area | Type | W/Cl | E | ST | Fa | Colour (out.) | Colour (in.) | Colour (sect.) | T | Pl. |
|-----|---------|----------|-------|------|----|-------|----|--|--|---|----|------|
| 429 | 09.1172 | L-1,B5A | 6B.7 | Cg/C | M | 2S | M | l.o.br. - 2.5 YR 5/6, o.y. - 2.5 YR 6/8 | r. - 2.5 YR 5/6, l.r. - 2.5 YR 6/8 | O: o.y. - 2.5 YR 6/8 C: g. - 5 YR 5/1 I: l.r. - 2.5 YR 6/8 | W | 27.1 |
| 430 | 08.299 | F20,d2 | 6C.1 | P/C | M | 1 | M | l.r. - 2.5 YR 6/6 | l.r. - 2.5 YR 6/6 | O: l.r. - 2.5 YR 6/6 C: r.g. - 2.5 YR 5/1 I: l.r. - 2.5 YR 6/6 | W | |
| 431 | 12.446 | L9,B5B | 6C.1 | P/C | M | 2S | M | l.br. - 7.5 YR 6/3 | l.br. - 7.5 YR 6/3 | l.br. - 7.5 YR 6/3 | W | |
| 432 | 09.958 | L9,c3 | 6C.2 | Ps/C | M | 4Bv | M | S: pi. - 7.5 YR 7/4 | S: pi. - 7.5 YR 7/4 | r.br. - 5 YR 5/4 | W | 21.7 |
| 433 | 08.941 | L1,B3 | 6C.2 | Rs/C | M | 4S | M | S: l.r. - 10 R 6/6 | l.r. - 2.5 YR 6/8 | O: l.r. - 2.5 YR 6/8 C: g. - GLEY 1 N 6 I: l.r. - 2.5 YR 6/8 | W | |
| 434 | 12.93 | L9,B2 | 6C.2 | P/C | C | 3 | M | Ss: p.y. - 2.5 Y 8/3 | r.br. - 5 YR 5/4 | O: r.br. - 5 YR 5/4 C: r. - 2.5 YR 5/6 I: r.br. - 5 YR 5/4 | W | |
| 435 | 12.253 | L9,B4 | 6C.2 | Ys/C | MC | 4S | M | S: p.y. - 5 Y 8/2 | S: p.y. - 5 Y 8/2 | l.br. - 7.5 YR 6/4 | W | |
| 436 | 08.388 | F20,a4 | 6C.2 | P/C | M | 2S | M | l.r. - 2.5 YR 6/8 | l.r. - 2.5 YR 6/8 | l.r. - 2.5 YR 6/8 | W | |
| 437 | 08.594 | H19,b3 | 6C.3 | P/C | M | 3 | M | pi. - 5 YR 7/4 | pi. - 5 YR 7/4 | pi. - 5 YR 7/4 | W | |
| 438 | 12.846 | L9,B8 | 6C.3 | Bb/C | M | 4Bo+v | M | S: r.y. - 5 YR 6/6 | S: l.r.br. - 5 YR 6/4 | r. - 2.5 YR 5/6 | W | |
| 439 | 12.252 | L9,B4 | 6C.3 | Ys/C | M | 4S | M | S: v.p.br. - 10 YR 8/3 | S: v.p.br. - 10 YR 8/3 | l.r. - 2.5 YR 6/6 | W | |
| 440 | 12.66 | L9,B2 | 6C.3 | Bb/C | M | 3Bo | M | Ss: r.y. - 5 YR 6/6 | r.y. - 5 YR 6/6 | r.y. - 5 YR 6/6 | W | |
| 441 | 12.865 | L9,B8 | 6C.3 | Ys/C | M | 4S | M | S: l.br. - 7.5 YR 6/4 | S: l.br. - 7.5 YR 6/4 | r.y. - 5 YR 6/6 | W | |
| 442 | 08.1062 | L2,B2 | 6C.4a | P/C | M | 2S | M | r. - 2.5 YR 5/6 | r. - 2.5 YR 5/6 | r. - 2.5 YR 5/6 | W | |
| 443 | 12.98 | L9,B2 | 6C.4b | P/C | M | 3Bo | M | Ss: v.p.br. - 10 YR 7/4 P: r.g. - 5 YR 5/2 | d.g. - 10 YR 4/1 | O: r.y. - 5 YR 6/6 I: d.g. - 10 YR 4/1 | W | |
| 444 | 09.796 | H15,d1 | 6C.5 | Pt/C | MF | 4 | M | S: v.p.br. - 10 YR 8/2 | S: l.br.g. - 10 YR 6/2 | br.y. - 10 YR 6/6 | W | 23.1 |
| 445 | 12.450 | L9,B5B | 6C.5 | Pt/C | M | 4S | M | P: b. - 10 YR 2/1 S: p.br. - 10 YR 6/3 | P: b. - 10 YR 2/1 S: p.br. - 10 YR 6/3 | s.br. - 7.5 YR 5/6 | W | |
| 446 | 08.929 | L1,B3 | 6C.6a | Rs/C | M | 4S | M | S: we.r. 10 R 4/4 | S: we.r. 10 R 4/4 | O: r. - 2.5 YR 5/6 C: r.br. - 5 YR 5/4 I: r. - 2.5 YR 5/6 | W | |
| 447 | 08.1467 | L2,B5 | 6C.6b | Rs/C | F | 4B | M | S: we.r. 10 R 5/4 | S: we.r. 10 R 5/4 | O: r. - 2.5 YR 5/6 C: r. - 2.5 YR 5/8 I: r. - 2.5 YR 5/6 | W | |
| 448 | 12.573 | L9,B6 | 6C.6b | Bb/C | M | 3Bo | M | Ss: s.br. - 7.5 YR 5/6 | s.br. - 7.5 YR 5/6 | O: s.br. - 7.5 YR 5/6 C: pi. - 5 YR 8/4, g.br. - 10 YR 5/2 I: s.br. - 7.5 YR 5/6 | W | |
| 449 | 12.444 | L9,B5B | 6C.6b | Rs/C | M | 4Bo | M | S: r. - 10 R 4/6 | br. - 7.5 YR 5/4 | O: br. - 7.5 YR 5/4 C: d.g. - 7.5 YR 4/1 I: br. - 7.5 YR 5/4 | W | |
| 450 | 12.254 | L9,B4 | 6C.7 | G/C | M | 2Bv | M | g. - 10 YR 6/1 | g. - 10 YR 6/1 | g. - 10 YR 6/1 | W | 21.6 |
| 451 | 12.440 | L9,B5B | 6C.7 | Cg/C | MC | 3 | M | Ss: r.y. - 7.5 YR 6/6 | Ss: r.y. - 5 YR 6/8 | l.g. - 2.5 Y 7/1 | W | |
| 452 | 12.58 | L9,B2 | 6C.8 | P/C | M | 3B | M | Ss: r.y. - 5 YR 7/6 | Ss: r.y. - 5 YR 7/6 | O: r.y. - 5 YR 7/8 C: r.y. - 5 YR 7/6 I: r.y. - 5 YR 7/8 | W | |
| 453 | 12.753 | L9,B7 | 6C.8 | Rs/C | C | 4S | M | S: r. - 2.5 YR 5/6 | r. - 2.5 YR 5/8 | O: r. - 2.5 YR 5/8 C: r.br. - 5 YR 4/3 I: r. - 2.5 YR 5/8 | W | |
| 454 | 12.1852 | L12,B1/2 | 6C.8 | Pt/C | M | 4S | M | P: r. - 10 R 5/6 S: pi. - 7.5 YR 8/3 | S: pi. - 7.5 YR 8/3 | O: r. - 10 R 5/8 I: g. - 5 YR 5/1 | W | |
| 455 | 09.515 | G14,a2 | 6C.9 | Cg/C | M | 2So | M | r. - 2.5 YR 5/6, pi. - 7.5 YR 7/4 | r. - 2.5 YR 5/6, pi. - 7.5 YR 7/4 | O: pi. - 7.5 YR 7/4 C: g. - 7.5 YR 5/1 I: pi. - 7.5 YR 7/4 | W | 27.1 |
| 456 | 08.300 | F20,d1 | 6C.9 | P/C | F | 2S | M | l.r. - 10 R 6/6 | l.r. - 10 R 6/6 | O: l.r. - 10 R 6/6 C: r.g. - 10 R 5/1 I: l.r. - 10 R 6/6 | W | |
| 457 | 12.521 | L9,B6 | 6C.9 | Rs/C | M | 4Bo | M | S: r. - 2.5 YR 5/6 | S: r. - 2.5 YR 5/6 | r.y. - 5 YR 6/6 | W | |
| 458 | 09.692 | H14,c1 | 6C.9 | Pt/C | F | 4Bv | M | P: d.br. - 7.5 YR 3/2 S: br. - 7.5 YR 5/4 | S: br. - 7.5 YR 5/4 | O: b. - 7.5 YR 4/3 I: g. - 7.5 YR 6/1 | HW | 25.4 |
| 459 | 09.1277 | L2,B2 | 6D | Rs/F | MF | 4P | M | S: r. - 2.5 YR 4/6 | S: r. - 2.5 YR 4/6, v.p.br. - 10 YR 8/4 | l.r. - 2.5 YR 6/6 | WH | 17.3 |
| 460 | 09.1278 | Gen. | 6D | P/C | M | 3B | M | Ss: r. - 2.5 YR 5/6 | r.y. - 5 YR 6/6 | O: r.y. - 5 YR 6/6 C: g. - 5 YR 6/1 I: r.y. - 5 YR 6/6 | W | |

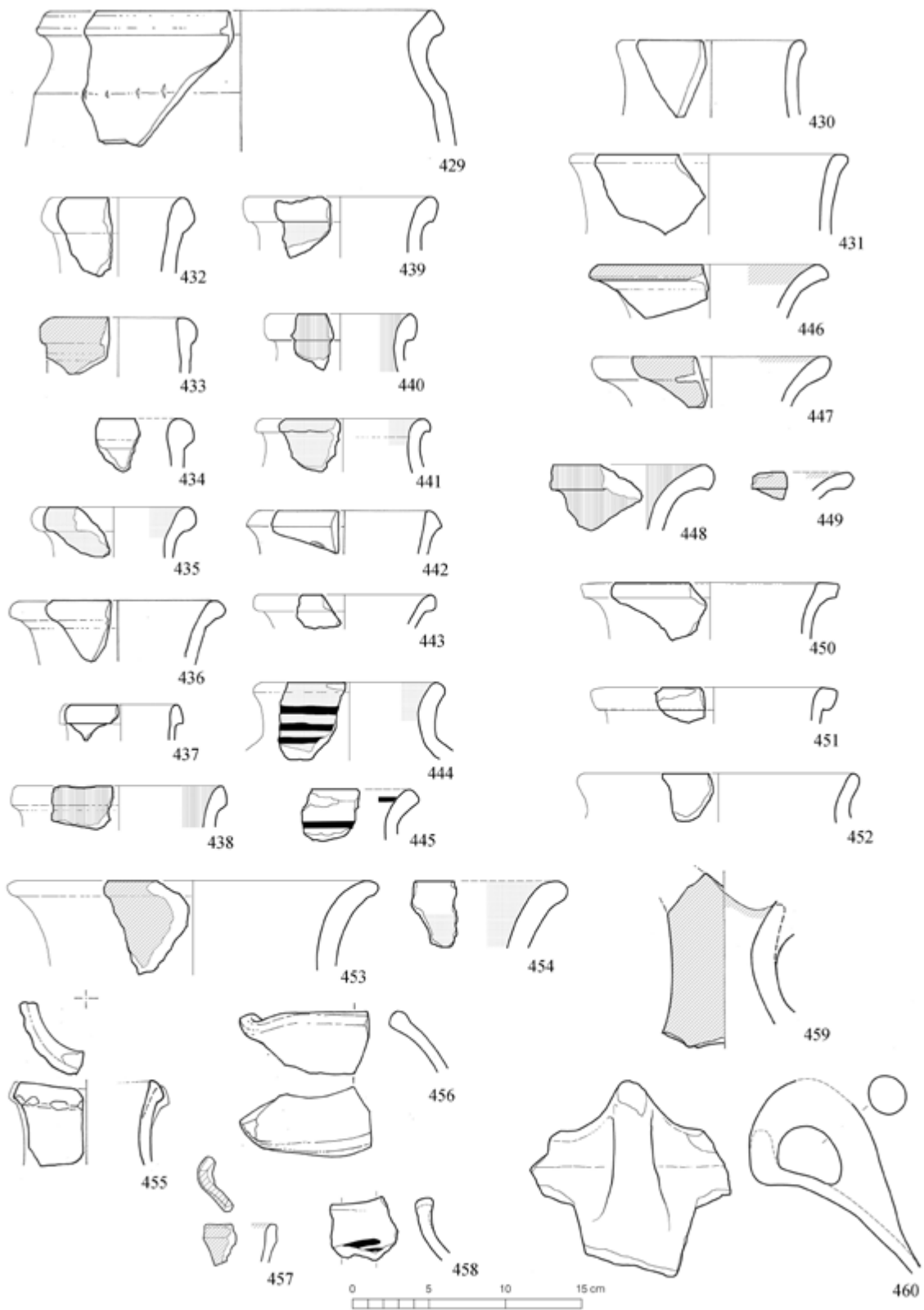


Fig. 20 – Pottery from Uşaklı Höyük.

Figure 21 – Type 7

| n. | UKn. | Area | Type | W/Cl | E | ST | Fa | Colour (out.) | Colour (in.) | Colour (sect.) | T | Pl. |
|-----|---------|-------|------|------|---|-----|----|---|-------------------------------------|--|---|------|
| 461 | 08.972 | L1,B4 | 7A | Rs/C | M | 3 | M | S: we.r. – 10 R 4/3 | S: we.r. – 10 R 4/3 | O: r. - 2.5 YR 5/6 C: d.g. GLEY 1 N 4 I: r. - 2.5 YR 5/6 | W | |
| 462 | 09.975 | L8,a1 | 7A | P/S | M | 2Bo | M | d.r.g. - 2.5 YR 4/1, r. - 2.5 YR 5/6 | p.r. - 10 R 6/4, r. - 2.5 YR 5/6 | O: r. - 2.5 YR 5/6 C: r.g. - 2.5 YR 5/1 I: r. - 2.5 YR 5/6 | W | 22.2 |
| 463 | 08.868 | L1,B1 | 7A | Rs/C | M | 4 | M | S: r. – 10 R 4/6 | S: r. – 10 R 4/6 | l.r.br. - 2.5 YR 6/4 | W | |
| 464 | 08.1819 | L3,B4 | 7A | Bb/S | M | 4 | M | S: br. – 7.5 YR 5/3 | S: br. – 7.5 YR 5/3 | br. – 7.5 YR 4/3 | W | |

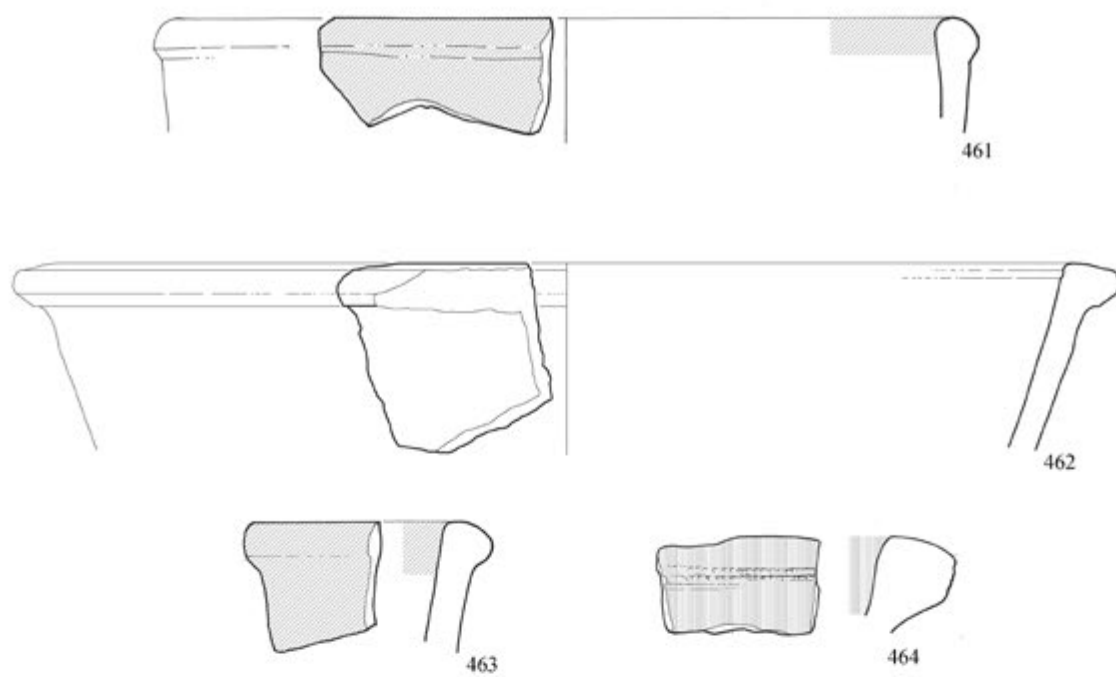


Fig. 21 – Pottery from Uşaklı Höyük.

Figure 22 – Type 8

| n. | UKn. | Area | Type | W/Cl | E | ST | Fa | Colour (out.) | Colour (in.) | Colour (sect.) | T | Pl. |
|-----|---------|--------|------|------|----|-----|----|--------------------------|------------------------|--|---|------|
| 465 | 08.544 | G19,a1 | 8A.1 | Rs/S | M | 4S | M | S: l.r. - 2.5 YR 6/8 | S: l.r. - 2.5 YR 6/8 | O: l.r. - 2.5 YR 6/6 C: gr.g. - GLEY 1 10 Y 6/1 I: l.r. - 2.5 YR 6/6 | W | |
| 466 | 12.869 | L9,B8 | 8A.1 | Ys/S | M | 3S | M | Ss: r.y. - 5 YR 6/6 | Ss: r.y. - 5 YR 6/6 | l.br. - 7.5 YR 6/4 | W | |
| 467 | 08.100 | J19 | 8A.1 | P/S | M | 3 | M | Ss: pi. - 5 YR 7/4 | Ss: pi. - 5 YR 7/4 | g. - 7.5 YR 6/1 | W | |
| 468 | 12.1310 | L11,B6 | 8A.1 | P/S | M | 3 | M | Ss: l.r.br. - 2.5 YR 6/4 | Ss: r.br. - 2.5 YR 5/4 | l.r. - 2.5 YR 7/6 | W | |
| 469 | 12.403 | L9,B5A | 8A.1 | P/C | M | 3S | M | Ss: p.br. - 10 YR 6/3 | r. - 2.5 YR 5/6 | O: r. - 2.5 YR 5/6 C: g. - 5 Y 5/1 I: r. - 2.5 YR 5/6 | W | |
| 470 | 08.431 | Gen. | 8A.2 | P/S | M | 2S | M | p.r. - 10 R 6/4 | p.r. - 10 R 6/4 | O: p.r. - 10 R 6/4 C: gr.g. - GLEY 1 10 Y 6/1 I: p.r. - 10 R 6/4 | W | |
| 471 | 09.378 | G17,c1 | 8A.2 | P/S | M | 2Bo | M | br. - 7.5 YR 5/2 | l.br. - 7.5 YR 6/3 | O: br. - 7.5 YR 5/2 C: g. - 7.5 YR 6/1 I: l.br. - 7.5 YR 6/3 | W | 21.4 |
| 472 | 09.797 | H15,d1 | 8A.3 | Ys/S | MC | 4B | M | S: pi. - 2.5 YR 8/3 | S: p.y. - 2.5 Y 8/3 | O: l.r. - 2.5 YR 6/6 C: l.br. - 7.5 YR 6/4 I: l.r. - 2.5 YR 6/6 | W | 23.7 |
| 473 | 08.1456 | L2,B5 | 8A.3 | Rs/S | M | 4B | M | S: l.r. - 2.5 YR 6/8 | S: l.r. - 2.5 YR 6/8 | O: l.r. - 10 R 6/6 C: l.g. - GLEY 1 N 7 I: l.r. - 10 R 6/6 | W | |
| 474 | 08.896 | L1,B2 | 8A.4 | P/S | M | 1 | M | l.br. - 7.5 YR 6/4 | l.br. - 7.5 YR 6/3 | O: l.br. - 7.5 YR 6/4 C: br. - 7.5 YR 5/4 I: l.br. - 7.5 YR 6/3 | W | |

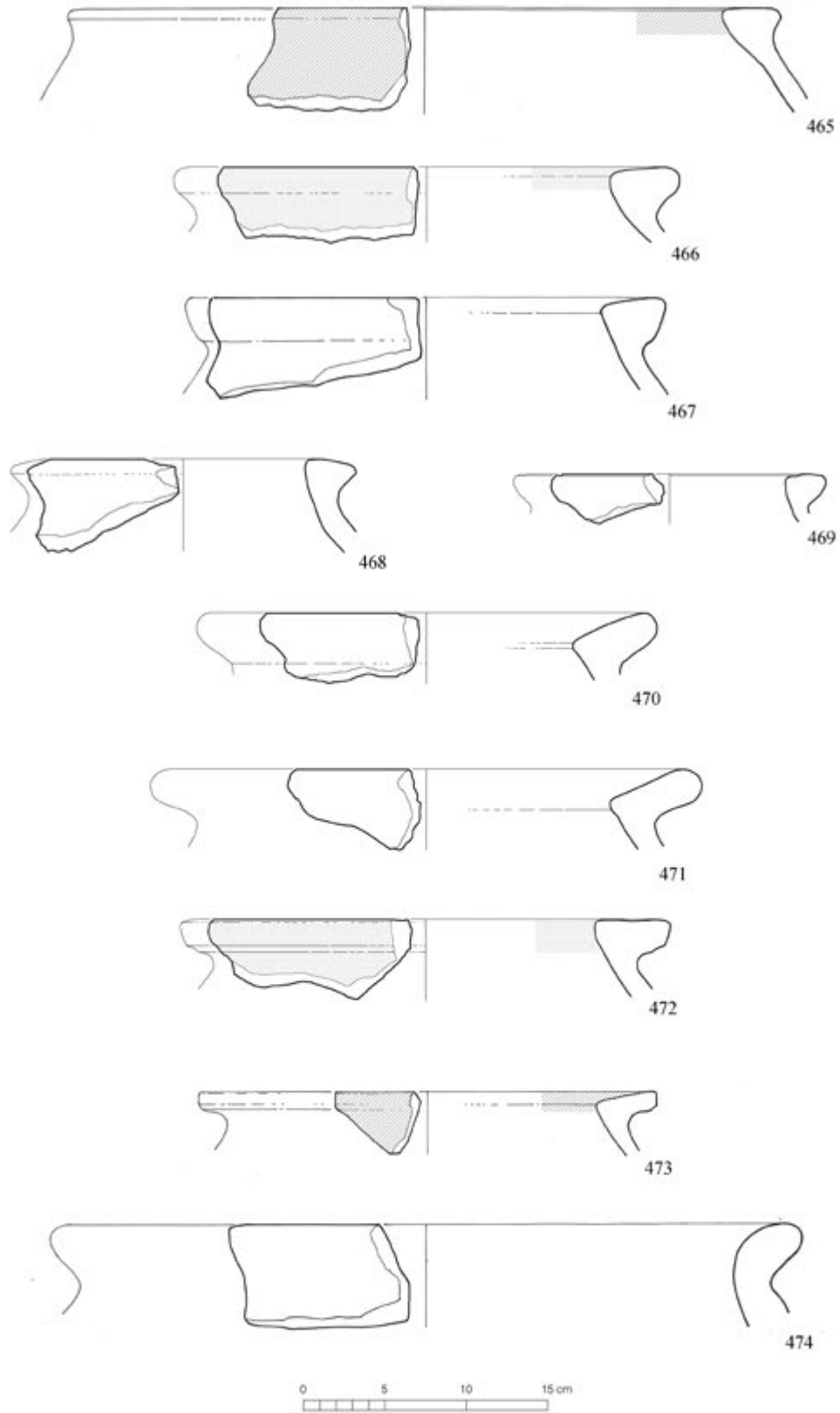


Fig. 22 – Pottery from Uşaklı Höyük.

Figure 23 – Type 8

| n. | UKn. | Area | Type | W/Cl | E | ST | Fa | Colour (out.) | Colour (in.) | Colour (sect.) | T | Pl. |
|-----|--------|--------|------|------|----|-----|----|------------------------|------------------------|---|---|------|
| 475 | 10.85 | L5,B5 | 8B.5 | P/S | M | 2S | M | l.r.br - 5 YR 6/3 | l.r.br - 5 YR 6/3 | l.r.br - 5 YR 6/3 | | W |
| 476 | 09.985 | L8,c4 | 8B.1 | Ps/S | M | 4S | M | S: p.y. - 2.5 Y 8/3 | S: p.y. - 2.5 Y 8/3 | O: r.br. - 5 YR 5/4 C: r.g. - 2.5 YR 6/1 I: r.br. - 5 YR 5/4 | W | 22.6 |
| 477 | 09.165 | F17,c3 | 8B.1 | P/S | M | 3Bo | M | Ss: l.br. - 7.5 YR 6/3 | Ss: l.br. - 7.5 YR 6/3 | O: r.y. - 5 YR 6/6 C: br. - 7.5 YR 5/3, g. - 7.5 YR 6/1 I: r.y. - 5 YR 6/6 | W | |
| 478 | 09.979 | L8,b2 | 8B.1 | P/S | M | 3S | M | Ss: pi.w. - 10 R 8/2 | Ss: g. - 10 YR 6/1 | O: r.y. - 5 YR 7/6 C: l.g. - 5 YR 7/1 I: r.y. - 5 YR 7/6 | W | 22.6 |
| 479 | 09.4 | L1,B2 | 8B.1 | Ys/S | MC | 4S | M | S: l.br. - 7.5 YR 6/4 | S: l.br. - 7.5 YR 6/3 | br. - 7.5 YR 5/4 | W | 22.5 |
| 480 | 08.289 | F20,d4 | 8B.1 | P/S | M | 2S | M | l.r. - 2.5 YR 6/6 | l.r. - 2.5 YR 6/6 | O: l.r. - 2.5 YR 6/6 C: g. - GLEY 1 N 6 I: l.r. - 2.5 YR 6/6 | W | |
| 481 | 08.427 | Gen. | 8B.1 | Rs/S | F | 4 | M | S: we.r. - 10 R 5/4 | p.r. - 10 R 6/4 | O: l.r. - 10 R 6/8 C: g. - 7.5 YR 6/1 I: p.r. - 10 R 6/4 | W | |
| 482 | 08.306 | F20,d1 | 8B.2 | Rs/S | C | 2S | M | we.r. - 10 R 5/4 | we.r. - 10 R 5/4 | we.r. - 10 R 5/4 | W | |

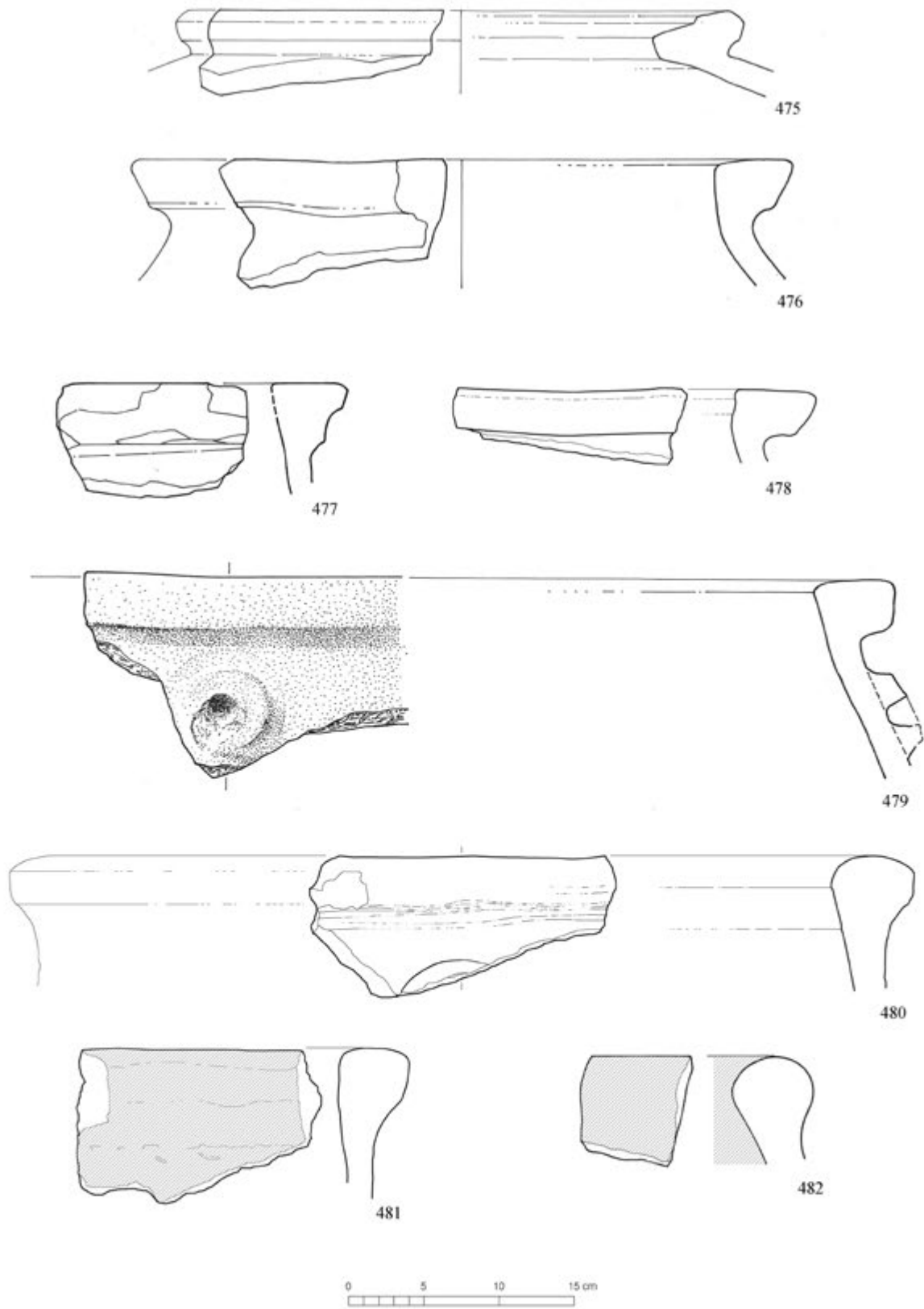


Fig. 23 – Pottery from Uşaklı Höyük.

Figure 24 – Type 8

| n. | UKn. | Area | Type | W/Cl | E | ST | Fa | Colour (out.) | Colour (in.) | Colour (sect.) | T | Pl. |
|-----|---------|---------|------|------|---|-----|----|------------------------|------------------------|--|---|------|
| 483 | 08.1545 | L3,B2 | 8B.2 | P/S | M | 3S | M | l.br. - 7.5 YR 6/4 | l.br. - 7.5 YR 6/4 | l.br. - 7.5 YR 6/3 | W | |
| 484 | 08.1026 | L2,B1 | 8B.2 | Rs/S | M | 4B | M | S: r. - 10 R 5/8 | S: r. - 10 R 5/8 | O: r.br. - 5 YR 5/4 C: l.r. - 2.5 YR 6/8 I: r.br. - 5 YR 5/4 | W | 17.7 |
| 485 | 08.1113 | L2,B2 | 8B.3 | Rs/S | M | 4 | M | S: we.r. - 10 R 5/4 | r. - 2.5 YR 5/6 | O: r.br. - 5 YR 5/4 I: r. - 2.5 YR 5/6 | W | 17.7 |
| 486 | 12.1623 | L11,B9 | 8B.3 | P/S | C | 1 | M | y.r. - 5 YR 5/6 | y.r. - 5 YR 5/6 | O: y.r. - 5 YR 5/6 C: g. - 5 YR 5/1 I: y.r. - 5 YR 5/6 | W | |
| 487 | 08.56 | J19 | 8B.3 | P/S | M | 3 | M | Ss: l.br. - 7.5 YR 6/3 | Ss: l.br. - 7.5 YR 6/3 | br. - 7.5 YR 5/3 | W | |
| 488 | 09.152 | F17,c4A | 8B.3 | P/S | M | 2So | M | l.br. - 7.5 YR 6/3 | br. - 7.5 YR 5/2 | O: l.br. - 7.5 YR 6/3 C: l.r. - 2.5 YR 6/8 I: br. - 7.5 YR 5/2 | W | |

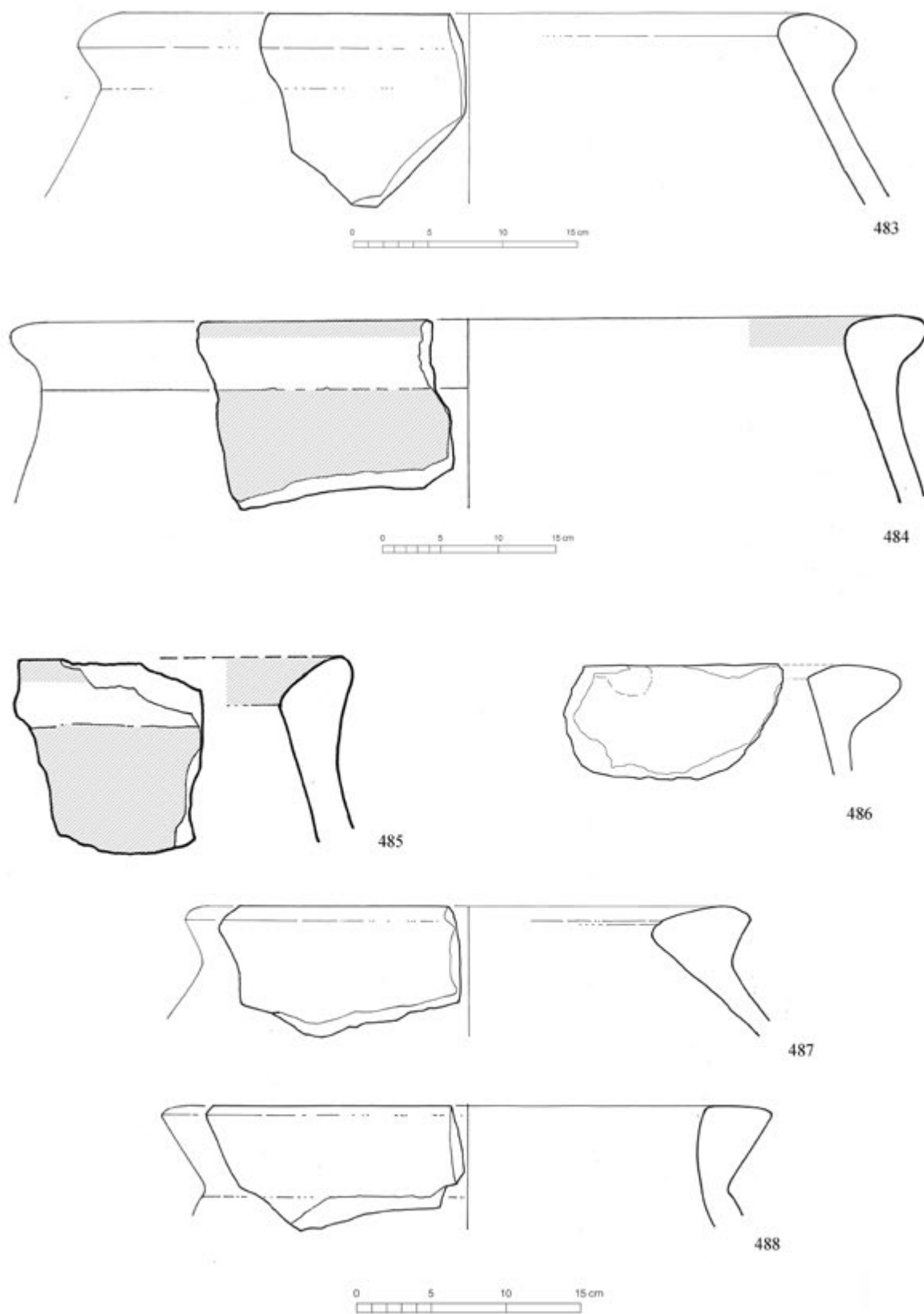


Fig. 24 – Pottery from Uşaklı Höyük.

Figure 25 – Type 8

| n. | UKn. | Area | Type | W/Cl | E | ST | Fa | Colour (out.) | Colour (in.) | Colour (sect.) | T | Pl. |
|-----|--------|--------|------|------|----|----|----|---------------------|---------------------|--|---|------|
| 489 | 08.334 | F20,c1 | 8B.3 | P/S | F | 2B | M | l.r. - 2.5 YR 6/6 | l.r. - 2.5 YR 6/6 | O: l.r. - 2.5 YR 6/6 C: g. - GLEY 1 N 6 I: l.r. - 2.5 YR 6/6 | W | |
| 490 | 12.533 | L9,B6 | 8B.3 | Rs/S | MC | 4S | M | S: we.r. - 10 R 4/3 | S: we.r. - 10 R 4/3 | O: ly.br. - 2.5 Y 6/3 C: g. - 2.5 Y 5/1 I: l.r. - 2.5 YR 6/6 | W | |
| 491 | 09.898 | E16,b2 | 8B.4 | P/S | MC | 3S | M | Ss: r.g. - 10 R 6/1 | Ss: r.g. - 10 R 6/1 | O: pi. - 7.5 YR 7/4 C: g. - 7.5 YR 5/1 I: pi. - 7.5 YR 7/4 | W | 22.6 |

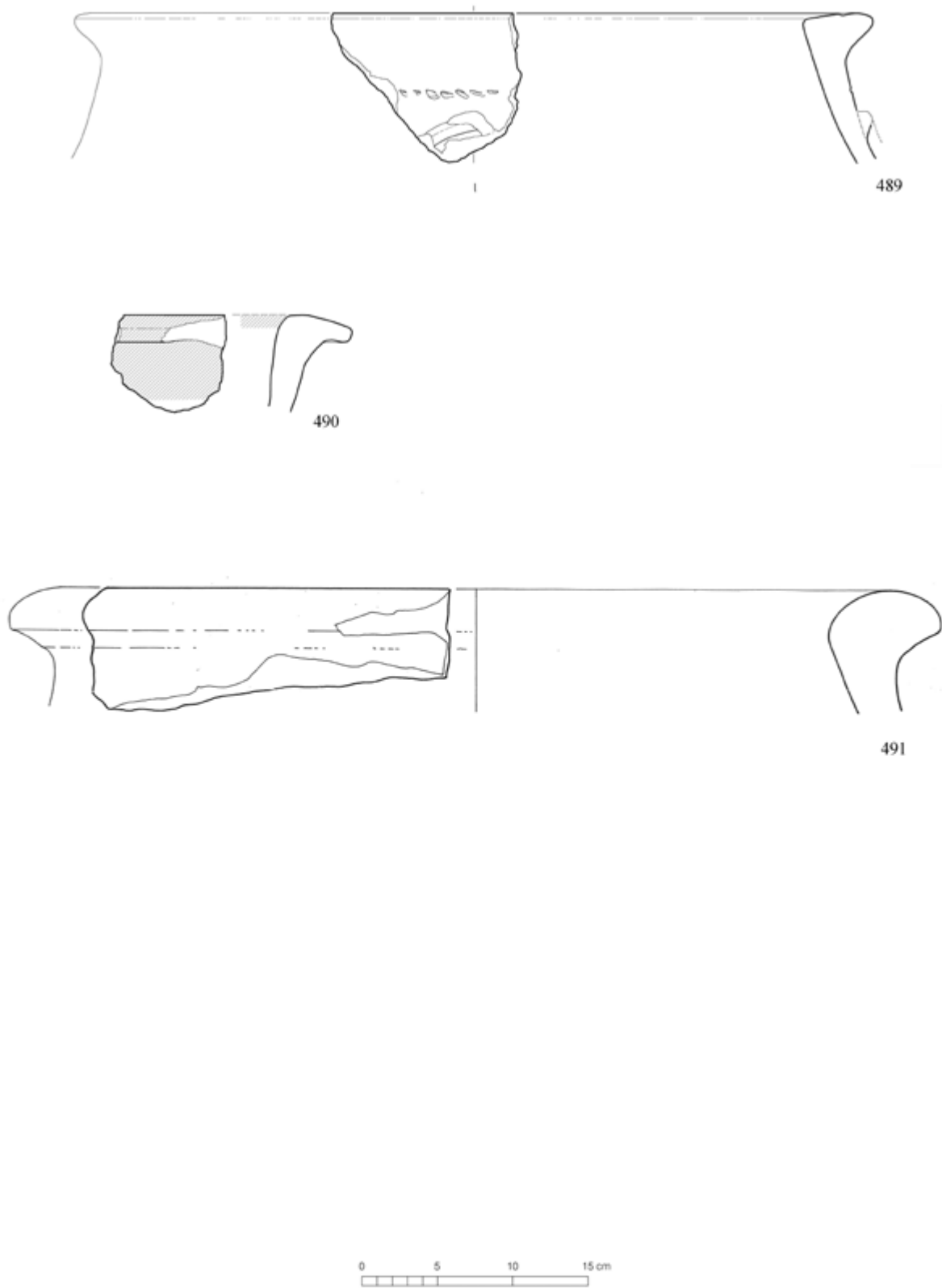


Fig. 25 – Pottery from Uşaklı Höyük.

Figure 26 – Type Z

| n. | UKn. | Area | Type | W/Cl | E | ST | Fa | Colour (out.) | Colour (in.) | Colour (sect.) | T | Pl. |
|-----|---------|--------|-------|------|----|-----|----|--|---|---|---|------|
| 492 | 08.1549 | L3,B2 | ZA.1 | Rs/C | M | 4B | M | S: we.r. - 10 R 5/3 | S: we.r. - 10 R 5/3 | O: r. - 2.5 YR 5/6 C: r.g. - 2.5 YR 5/1 I: r. - 2.5 YR 5/6 | W | |
| 493 | 08.1760 | L3,B3 | ZA.2a | Rs/C | M | 4S | M | S: we.r. - 10 R 5/4 | S: we.r. - 10 R 5/4 | O: r. - 2.5 YR 5/6 C: r.br. - 5 YR 5/4 I: r. - 2.5 YR 5/6 | W | |
| 494 | 08.728 | I19,b4 | ZA.2c | Rs/C | M | 4B | M | S: p.r. - 10 R 6/4 | S: we.r. - 10 R 5/4 | O: l.r.br. - 5 YR 6/4 C: r. - 2.5 YR 5/6 I: l.r.br. - 5 YR 6/4 | W | |
| 495 | 12.1289 | L11,B6 | ZA.2b | Rs/C | M | 4S | M | S: r. - 10 R 5/6 | l.r. - 2.5 YR 7/6 | O: l.r. - 2.5 YR 7/6 C: l.r.br. - 2.5 YR 6/4 I: l.r. - 2.5 YR 7/6 | W | |
| 496 | 10.179 | L8,B7 | ZA.2b | Rs/C | M | 4B | M | S: we.r. - 10 R 5/4, r.br. - 5 YR 5/3 | S: r.br. - 5 YR 5/3 | O: r.br. - 5 YR 5/4 C: d.g. - 5 YR 4/1 I: r.br. - 5 YR 5/4 | W | |
| 497 | 08.2030 | L4,B3 | ZA.2c | Rs/C | M | 4B | M | S: we.r. - 10 R 5/4 | S: we.r. - 10 R 5/4 | O: l.r. - 10 R 6/8 C: d.g. - 7.5 YR 4/1 I: l.r. - 10 R 6/8 | W | 29 |
| 498 | 08.1284 | L2,B3 | ZA.3a | Rs/C | MF | 4B | M | S: r. - 2.5 YR 5/8 | S: r. - 2.5 YR 5/8 | O: br. - 7.5 YR 5/2 C: br. - 7.5 YR 5/2, y.r. - 5 YR 5/6 I: br. - 7.5 YR 5/2 | W | |
| 499 | 08.777 | F19,a4 | ZA.3b | Rs/C | M | 4 | M | S: r. - 10 R 4/6 | S: r. - 10 R 4/6 | r.y. - 5 YR 6/6 | W | |
| 500 | 08.1638 | L3,B3 | ZA.3b | Rs/C | M | 4B | M | S: we.r. - 10 R 5/3 | S: we.r. - 10 R 5/4 | O: r.br. - 5 YR 4/4 C: r.br. - 5 YR 4/4, d.g. - GLEY 1 N 4 I: r.br. - 5 YR 4/4 | W | 29 |
| 501 | 08.1323 | L2,B4 | ZA.3b | Rs/C | M | 4S | M | S: pi.g. - 5 YR 7/2 | S: pi.g. - 5 YR 7/2 | d.g. - 7.5 YR 4/1 | W | |
| 502 | 08.1311 | L2,B4 | ZA.3b | P/C | M | 3S | M | Ss: y.r. - 5 YR 5/6 | y.r. - 5 YR 5/6 | O: y.r. - 5 YR 5/6 C: pi.g. - 7.5 YR 6/2 I: y.r. - 5 YR 5/6 | W | |
| 503 | 12.576 | L9,B6 | ZA.3b | P/C | M | 1 | M | r. - 2.5 YR 5/8 | r. - 2.5 YR 5/8 | r. - 2.5 YR 5/8 | W | |
| 504 | 08.743 | I19,a2 | ZA.4 | P/C | M | 2S | M | l.r. - 2.5 YR 6/8 | l.r. - 2.5 YR 6/8 | we.r. - 2.5 YR 5/2 | W | |
| 505 | 12.359 | L9,B5A | ZA.4 | P/C | M | 2S | M | r.y. - 5 YR 6/6 | r.y. - 5 YR 6/6 | r.y. - 5 YR 6/6 | W | |
| 506 | 08.920 | L1,B3 | ZA.5 | Ps/C | M | 4S | M | S: pi. - 5 YR 7/4 | S: pi. - 5 YR 7/4 | l.r.br. - 5 YR 6/4 | W | |
| 507 | 08.1711 | L3,B3 | ZA.5 | P/C | M | 2B | M | r.br. - 5 YR 5/4 | r.br. - 5 YR 5/4 | r.br. - 5 YR 5/4 | W | |
| 508 | 12.449 | L9,B5B | ZA.6a | P/C | M | 2S | M | y.r. - 5 YR 5/8 | y.r. - 5 YR 5/8 | y.r. - 5 YR 5/8 | W | |
| 509 | 09.982 | L8,a1 | ZA.6a | Cg/C | MC | 2S | M | r.br. - 2.5 YR 5/4, r.br. - 5 YR 5/4 | r.br. - 2.5 YR 5/4, r.br. - 5 YR 5/4 | O: y.r. - 5 YR 5/6 C: g. - 5 YR 5/1 I: y.r. - 5 YR 5/6 | W | 26.5 |
| 510 | 08.1900 | L3,B5 | ZA.6b | Rs/C | F | 4S | M | S: r. - 2.5 YR 5/8 | S: r. - 2.5 YR 5/8 | O: r. - 2.5 YR 5/6 C: d.g. - GLEY 1 N 4 I: r. - 2.5 YR 5/6 | W | |
| 511 | 09.939 | L9,a2 | ZA.6b | P/C | MF | 3Bo | M | Ss: r. - 2.5 YR 5/6 | Ss: r. - 2.5 YR 5/6 | O: y.r. - 5 YR 5/6 C: d.r.g. - 2.5 YR 4/1 I: y.r. - 5 YR 5/6 | W | |
| 512 | 08.237 | K19,a2 | ZA.7 | Rs/C | M | 4B | M | S: pi. - 5 YR 7/4 | S: we.r. - 10 R 5/3 | r. - 2.5 YR 5/6 | W | 29 |

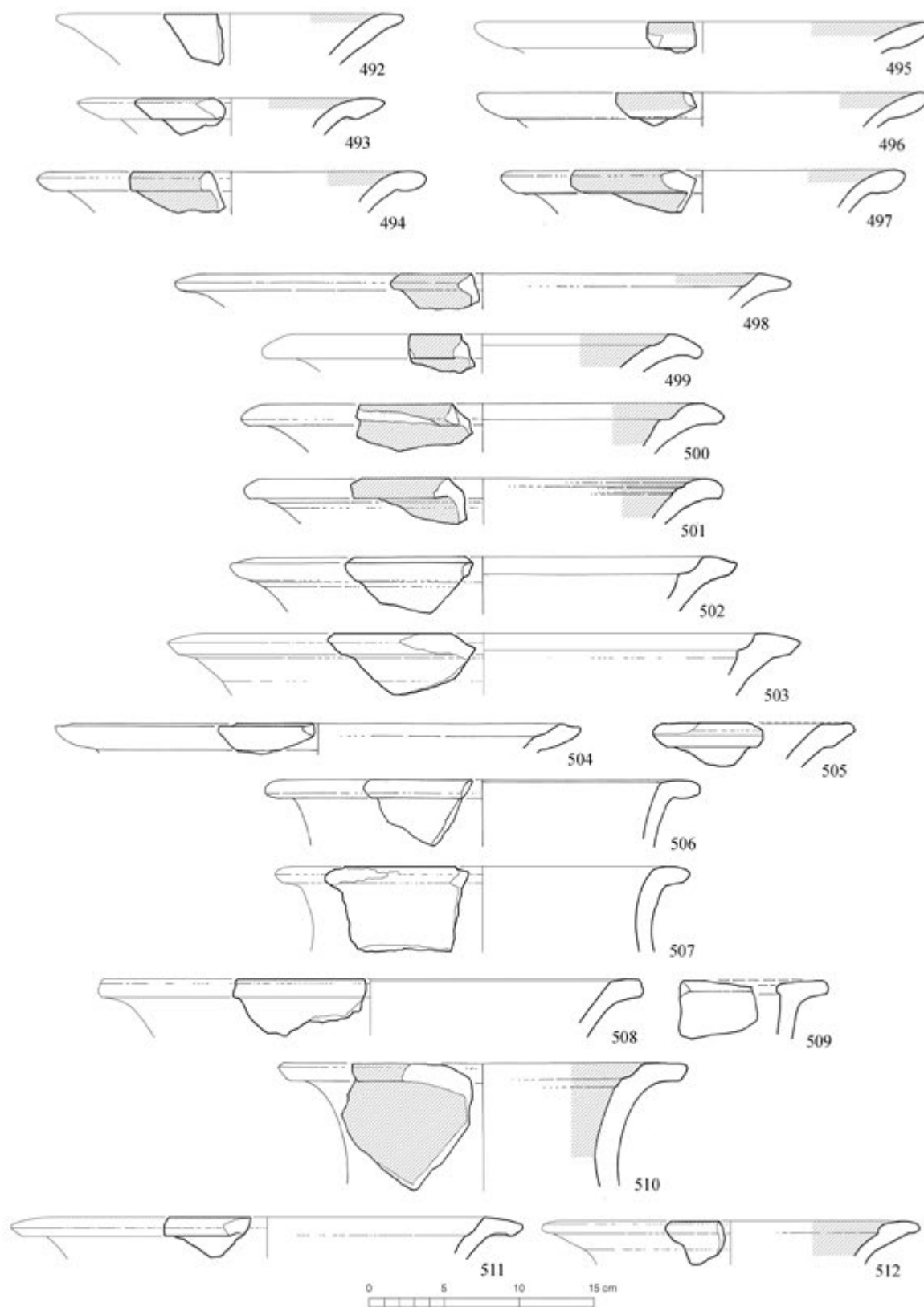


Fig. 26 – Pottery from Uşaklı Höyük.

Figure 27 – Type Z

| n. | UKn. | Area | Type | W/Cl | E | ST | Fa | Colour (out.) | Colour (in.) | Colour (sect.) | T | Pl. |
|-----|---------|--------|------|------|----|-----|----|--|---|--|---|------|
| 513 | 09.324 | F16,c1 | ZA.8 | Pt/C | MF | 3Bo | M | P: r.br. - 5 YR 5/4, l.br.g. - 10 YR 6/2 Ss: g. - 10 YR 6/1 | P: r.br. - 5 YR 5/4, l.br.g. - 10 YR 6/2 s: g. - 10 YR 6/1 | O: g. - 10 YR 6/1 C: g. - 2.5 Y 6/1 I: g. - 10 YR 6/1 | W | 25.4 |
| 514 | 08.2021 | HM | ZA.8 | Pt/C | M | 4B | M | P: d.r.g. - 10 R 3/1 S: l.r.br. - 5 YR 6/4 | l.r.br. - 2.5 YR 6/4 | l.r.br. - 2.5 YR 6/4 | W | |
| 515 | 09.773 | H15,d4 | ZA.8 | Pt/C | MF | 4S | M | P: d.r.g. - 10 R 3/1 S: l.br. - 7.5 YR 6/4 | S: l.br. - 7.5 YR 6/4 | r. - 2.5 YR 5/8 | W | 25.1 |
| 516 | 09.309 | F16,b2 | ZA.8 | Pt/C | M | 4Bo | M | P: d.r.g. - 5 YR 4/2 S: r.y. - 7.5 YR 7/6 | P: d.r.g. - 5 YR 4/2 S: r.y. - 7.5 YR 7/6 | r.y. - 5 YR 6/6 | W | 23.6 |
| 517 | 12.140 | L9,B3 | ZA.8 | Ys/C | M | 4Bo | M | S: pi. - 7.5 YR 7/4 | y.r. - 5 YR 5/8 | O: y.r. - 5 YR 5/8 C: l.br. - 7.5 YR 6/4 I: y.r. - 5 YR 5/8 | W | |
| 518 | 12.1005 | L9,B9 | ZA.8 | Pt/C | M | 4Bo | M | P: d.r.g. - 5 YR 4/2 S: v.p.br. - 10 YR 7/4 | P: d.r.g. - 5 YR 4/2 S: v.p.br. - 10 YR 7/4 | r.y. - 5 YR 6/6 | W | |
| 519 | 10.86 | L5,B5 | ZA.8 | Pt/C | M | 4B | M | P: d.r.g. - 10 R 4/1 S: pi. - 7.5 YR 7/4 | S: pi. - 7.5 YR 7/4 | l.br. - 7.5 YR 6/4 | W | |
| 520 | 12.609 | L9,B8 | ZA.8 | Pt/C | M | 4Bo | M | P: b. - 2.5 YR 2.5/1 S: v.p.br. - 10 YR 8/3 | S: v.p.br. - 10 YR 8/3 | O: r.y. - 5 YR 6/6 C: l.r. - 2.5 YR 6/6 I: r.y. - 5 YR 6/6 | W | |
| 521 | 12.610 | L9,B6 | ZA.8 | Pt/C | M | 4S | M | P: b. - 2.5 YR 2.5/1 S: v.p.br. - 10 YR 8/3 | S: v.p.br. - 10 YR 8/3 | r. - 2.5 YR 5/6 | W | |
| 522 | 12.1342 | L11,B6 | ZA.8 | Pt/C | M | 4B | M | P: d.r.g. - 2.5 YR 3/1 S: we.r. - 10 R 5/4 | P: d.r.g. - 2.5 YR 3/1 S: we.r. - 10 R 5/4 | l.r. - 2.5 YR 6/6 | W | |
| 523 | 09.181 | G17,b1 | ZA.8 | Pt/C | M | 4Bo | M | P: r.br. - 5 YR 4/3, v.p.br. - 10 YR 8/3 S: l.br. - 7.5 YR 6/4 | S: l.br. - 7.5 YR 6/4 | O: r. - 2.5 YR 5/6 C: g. - 5 YR 5/1 I: y.r. - 5 YR 5/6 | W | 24.7 |
| 524 | 08.2204 | Gen. | ZA.9 | Ps/C | F | 4B | M | S: pi. - 7.5 YR 7/4 | S: pi. - 7.5 YR 7/4 | r. - 2.5 YR 5/6 | W | |
| 525 | 09.158 | F17,b3 | ZA.9 | Pt/C | M | 2Bo | M | P: r. - 10 R 5/6 s: l.br. - 7.5 YR 6/4 | P: r. - 10 R 5/6 s: l.br. - 7.5 YR 6/4 | O: l.br. - 7.5 YR 6/4 C: l.r.br. - 2.5 YR 6/4 I: l.br. - 7.5 YR 6/4 | W | 24.7 |

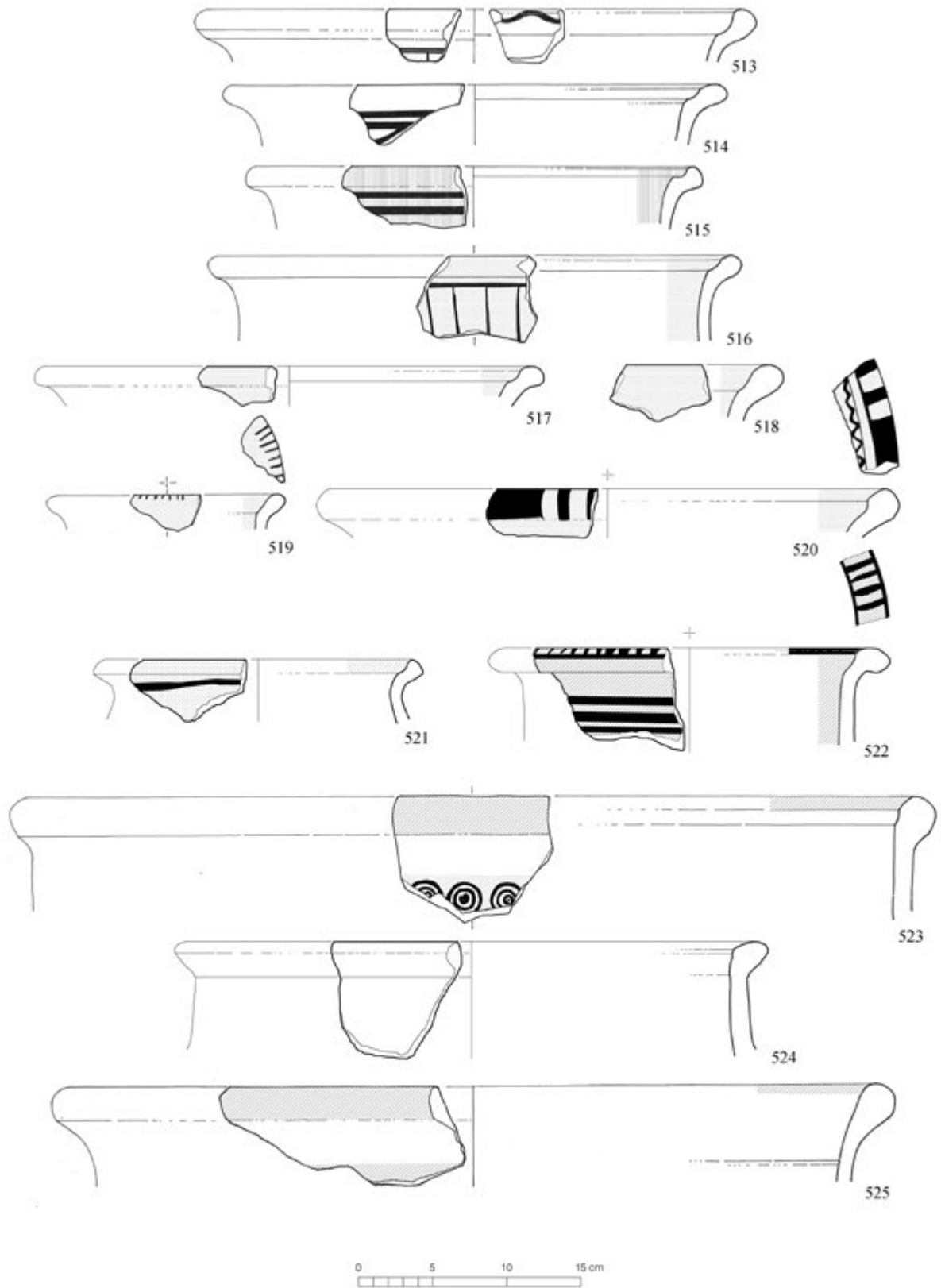


Fig. 27 – Pottery from Uşaklı Höyük.

Figure 28 – Type Z

| n. | UKn. | Area | Type | W/Cl | E | ST | Fa | Colour (out.) | Colour (in.) | Colour (sect.) | T | Pl. |
|-----|---------|---------|-------|------|----|-----|----|--|--|---|---|--------|
| 526 | 08.548 | HM | ZA.10 | Pt/C | M | 3P | M | P: d.r.g. - 5 YR 4/2 s: l.r. - 2.5 YR 6/8 | P: d.r.g. - 5 YR 4/2 Ss: l.r. - 2.5 YR 6/6 | l.r. - 2.5 YR 6/8 | | W |
| 527 | 08.680 | I19,c4 | ZA.10 | Pt/C | F | 3P | M | P: w.r. - 10 R 4/2 Ss: l.b. - 7.5 YR 6/4 | P: w.r. - 10 R 4/2 Ss: l.b. - 7.5 YR 6/4 | l.r. - 2.5 YR 6/8 | | W 25.1 |
| 528 | 12.138 | L9,B3 | ZA.10 | Pt/C | M | 4Bo | M | P: v.d.g. - 5 YR 3/1 S: r.y. - 7.5 YR 6/6 | S: r.y. - 7.5 YR 6/6 | ly.br. - 2.5 Y 6/3 | | W |
| 529 | 12.255 | L9,B4 | ZA.10 | Pt/C | M | 4S | M | P: d.r.g. - 10 R 4/1 S: v.p.br. - 10 YR 8/3 | P: d.r.g. - 10 R 4/1 S: v.p.br. - 10 YR 8/3 | O: r.y. - 5 YR 6/6 C: l.y.br. - 10 YR 6/4 I: r.y. - 5 YR 6/6 | | W |
| 530 | 09.776 | H15,d3 | ZA.10 | G/C | M | 2B | M | d.g. - GLEY 1 N 4 + | d.g. - GLEY 1 N 4 | O: d.g. - GLEY 1 N 4 C: g. - GLEY 1 N 5 I: d.g. - GLEY 1 N 4 | | W 21.4 |
| 531 | 09.1246 | L-2,B2C | ZA.10 | Pt/C | M | 4B | M | P: v.d.g. - 5 YR 3/1 S: v.p.br. - 10 YR 8/3 | P: v.d.g. - 5 YR 3/1 S: v.p.br. - 10 YR 8/3 | O: l.r. - 2.5 YR 6/6 C: r.y. - 7.5 YR 6/8 I: r. - 2.5 YR 5/6 | | W 24.7 |
| 532 | 12.1290 | L11,B6 | ZA.10 | Rs/C | M | 4B | M | S: r. - 10 R 5/8 | S: r. - 10 R 5/8 | d.r.g. - 2.5 YR 4/1 | | W |
| 533 | 09.1105 | D9,d1 | ZA.10 | Pt/C | M | 4S | M | P: we.r. - 2.5 YR 4/2 S: pi. - 7.5 YR 7/4 | P: we.r. - 2.5 YR 4/2 S: pi. - 7.5 YR 7/4 | O: r.y. - 5 YR 6/6 C: l.br. - 7.5 YR 6/4 I: r.y. - 5 YR 6/6 | | W 25.1 |
| 534 | 12.1362 | L11,B7 | ZA.10 | Rs/C | M | 4B | M | S: we.r. - 10 R 5/4 | S: we.r. - 10 R 5/4 | O: r.y. - 5 YR 6/6 C: g. - 5 YR 6/1 I: r.y. - 5 YR 6/6 | | W |
| 535 | 08.855 | Gen. | ZA.11 | Bb/C | M | 4S | M | S: r.br. - 2.5 YR 5/4 | S: r.br. - 2.5 YR 5/4 | l.r. - 10 R 6/6 | | W |
| 536 | 08.1111 | L2,B2 | ZA.11 | Rs/C | M | 4B | M | S: d.r. - 10 R 3/6 | S: d.r. - 10 R 3/6 | O: y.r. - 5 YR 5/6 C: l.g. - 5 YR 7/1 I: y.r. - 5 YR 5/6 | | W |
| 537 | 12.236 | L9,B4 | ZC | Bb/C | M | 4B | M | S: y.r. - 5 YR 5/6 | S: y.r. - 5 YR 5/6 | y.r. - 5 YR 5/8 | | W |
| 538 | 09.875 | F15,b4 | ZC | Bb/C | MF | 3Bo | M | Ss: r.y. - 5 YR 6/8 | Ss: r.y. - 5 YR 6/8 | O: l.r. - 2.5 YR 6/6 C: r. - 2.5 YR 5/6 I: l.r. - 2.5 YR 6/6 | | W |
| 539 | 09.1040 | L11,b3 | ZC | P/C | M | 2So | M | v.p.br. - 10 YR 8/2 | pi. - 7.5 YR 7/4 | O: v.p.br. - 10 YR 8/2 C: r.y. - 7.5 YR 7/6 I: pi. - 7.5 YR 7/4 | | W |

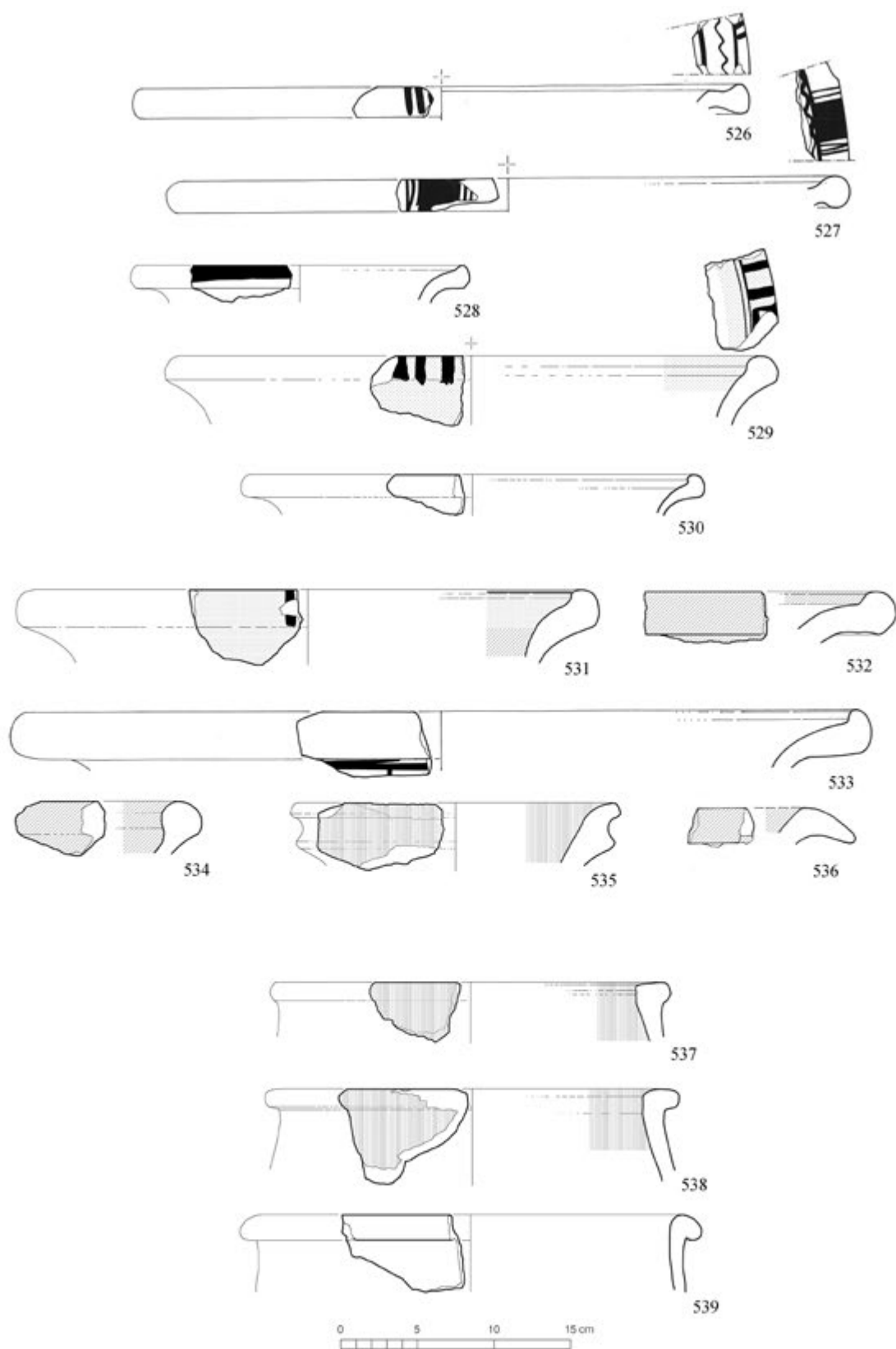


Fig. 28 – Pottery from Uşaklı Höyük.

Figure 29 – Type 20 and W

| n. | UKn. | Area | Type | W/Cl | E | ST | Fa | Colour (out.) | Colour (in.) | Colour (sect.) | T | Pl. | |
|-----|---------|---------|-------|--------|----|-------|----|---|------------------------------------|---|---|------|------|
| 540 | 08.291 | F20,d3 | 20A.1 | Rs/C | F | 4B | M | S: r. - 10 R 4/6 | r.br. - 5 YR 5/4 | r.br. - 5 YR 5/4 | | W | |
| 541 | 09.3 | L1,B2 | 20A.2 | Rs/C | M | 4B | M | S: r. - 2.5 YR 5/6 | S: r. - 2.5 YR 5/6 | O: l.r.br. - 5 YR 6/4 C: br. - 7.5 YR 5/4 I: l.r.br. - 5 YR 6/4 | W | 17.4 | |
| 542 | 08.1943 | L4,B2 | 20A.1 | P/C | M | 3B | M | Ss: r. - 2.5 YR 5/6 | r. - 2.5 YR 5/6 | r. - 2.5 YR 5/6 | | W | |
| 543 | 12.286 | L9,B4 | 20A.2 | Rs/C | M | 4P | M | S: y.br. - 10 YR 5/4 | S: y.br. - 10 YR 5/4 | y.br. - 10 YR 5/6 | | H | |
| 544 | 08.1458 | L2,B5 | 20A.2 | Rs/C | F | 3 | M | Ss: y.r. - 5 YR 5/6 | Ss: y.r. - 5 YR 5/6 | g. - 7.5 YR 6/1 | | W | |
| 545 | 08.1139 | L2,B3 | 20A.2 | Rs/C | F | 4P | M | S: r. - 2.5 YR 5/6 | S: r. - 2.5 YR 5/6 | r. - 2.5 YR 5/8 | | W | |
| 546 | 08.424 | TS | 20C.1 | Rs/C | F | 4P | M | S: r. - 10 R 4/6 | r.y. - 5 YR 6/6 | r.y. - 5 YR 6/6 | | W | |
| 547 | 08.1163 | L2,B3 | 20C.2 | Rs/C | M | 4S | M | S: l.r. - 2.5 YR 6/6 | S: l.r. - 2.5 YR 6/6 | y.r. - 5 YR 5/6 | | W | |
| 548 | 08.1106 | L2,B2 | 20C.3 | P/C | M | 3 | M | Ss: y.r. - 5 YR 5/6 | Ss: y.r. - 5 YR 5/6 | r.br. - 5 YR 5/4 | | W | |
| 549 | 09.1221 | D14,b2 | 20C.4 | P/C | MF | 2B | M | l.r.br - 5 YR 6/3, r.y. - 5 YR 6/6 | l.r.br - 5 YR 6/3, r.y. - 5 YR 6/6 | O: r.y. - 5 YR 6/6 C: g. - 5 YR 5/1 I: r.y. - 5 YR 6/6 | H | 22.1 | |
| 550 | 08.1245 | L2,B3 | 20C.4 | P/C | M | 2 | M | r.br. - 5 YR 5/4 | r.br. - 5 YR 5/4 | O: r.br. - 5 YR 5/4 C: g. - GLEY 1 N 5 I: r.br. - 5 YR 5/4 | | W | |
| 551 | 09.1279 | L3,B3 | 20C.5 | Rs/F | F | 4P | M | S: y.r. - 5 YR 4/6 | pi. - 5 YR 7/4 | pi. - 5 YR 7/4 | | W | 17.5 |
| 552 | 12.1131 | L11,B3 | 9 | Pt/C-F | MF | 4P | M | P: d.r.g. - 5 YR 4/2 S: pi.w. - 7.5 YR 8/2 | l.r. - 2.5 YR 6/6 | O: l.r.br. - 2.5 YR 6/3 C: g. - 2.5 Y 6/1 I: l.r. - 2.5 YR 6/6 | W | 23.5 | |
| 553 | 09.443 | G18,a4 | 11 | P/C | M | 2S | M | l.r.br - 5 YR 6/4 | l.r. - 10 R 6/6 | O: l.r.br - 5 YR 6/4 C: r.y. - 5 YR 6/6 I: l.r. - 10 R 6/6 | | W | |
| 554 | 12.67 | L9,B2 | W | P/C | C | 3 | M | Ss: r.y. - 7.5 YR 7/6 | Ss: r.y. - 7.5 YR 7/6 | l.r. - 2.5 YR 6/8 | | W | |
| 555 | 12.65 | L9,B2 | W | P/C | M | 3 | M | Ss: r.y. - 5 YR 7/8 | Ss: r.y. - 5 YR 7/8 | pi. - 5 YR 8/4 | | W | |
| 556 | 09.1247 | L-2,B2B | W | Bb/C | M | 3S | M | Ss: r.y. - 5 YR 6/6 | Ss: r.y. - 5 YR 6/6 | l.r. - 2.5 YR 6/6 | | W | 27.7 |
| 557 | 08.290 | F20,d3 | W | Rs/C | MF | 4Bv+o | M | S: r. - 2.5 YR 5/6 | S: r. - 2.5 YR 5/6 | O: r. - 2.5 YR 5/8 C: l.br. - 7.5 YR 6/4 I: r. - 2.5 YR 5/8 | | W | |

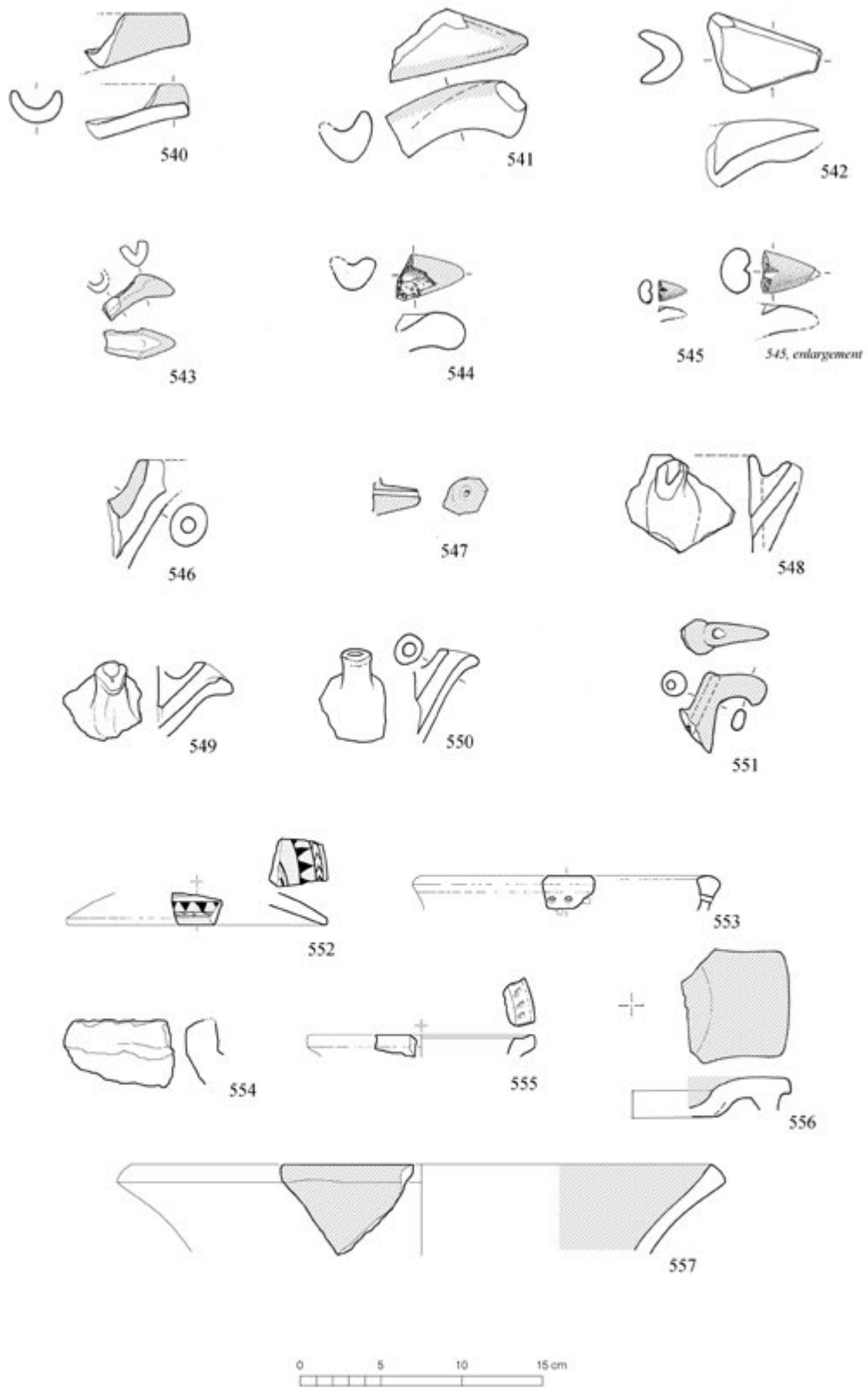


Fig. 29 – Pottery from Uşaklı Höyük.

Figure 30 – Various types

| n. | UKn. | Area | Type | W/Cl | E | ST | Fa | Colour (out.) | Colour (in.) | Colour (sect.) | T | Pl. |
|-----|--------|---------|------|------|----|-----|----|--|-----------------------------|--|---|------|
| 558 | 09.899 | E16,c4 | W | Pt/F | MF | 4B | M | P: br. - 10 YR 4/3, r. - 2.5 YR 5/8 S: v.p.br. - 10 YR 8/4 | S: pi. - 7.5 YR 7/3 | l.r. - 2.5 YR 7/8 | W | 24.1 |
| 559 | 10.223 | SS1 wnw | W | Ys | M | 4Bv | M | S: py. - 5 Y 8/2 | pi. - 7.5 YR 7/4 | pi. - 7.5 YR 7/4 | W | 41.2 |
| 560 | 08.797 | F19,b3 | W | Ys | F | 4P | M | S: r.y. - 7.5 YR 7/6 | S: r.y. - 7.5 YR 7/6 | O: pi. - 7.5 YR 7/4 C: v.p.b. - 10 YR 8/3 I: pi. - 7.5 YR 7/4 | W | |
| 561 | 09.389 | G17,d3 | W | P/C | F | 2So | M | r.y. - 5 YR 7/6 | r.y. - 5 YR 7/6 | r.y. - 5 YR 7/6 | W | 27.1 |

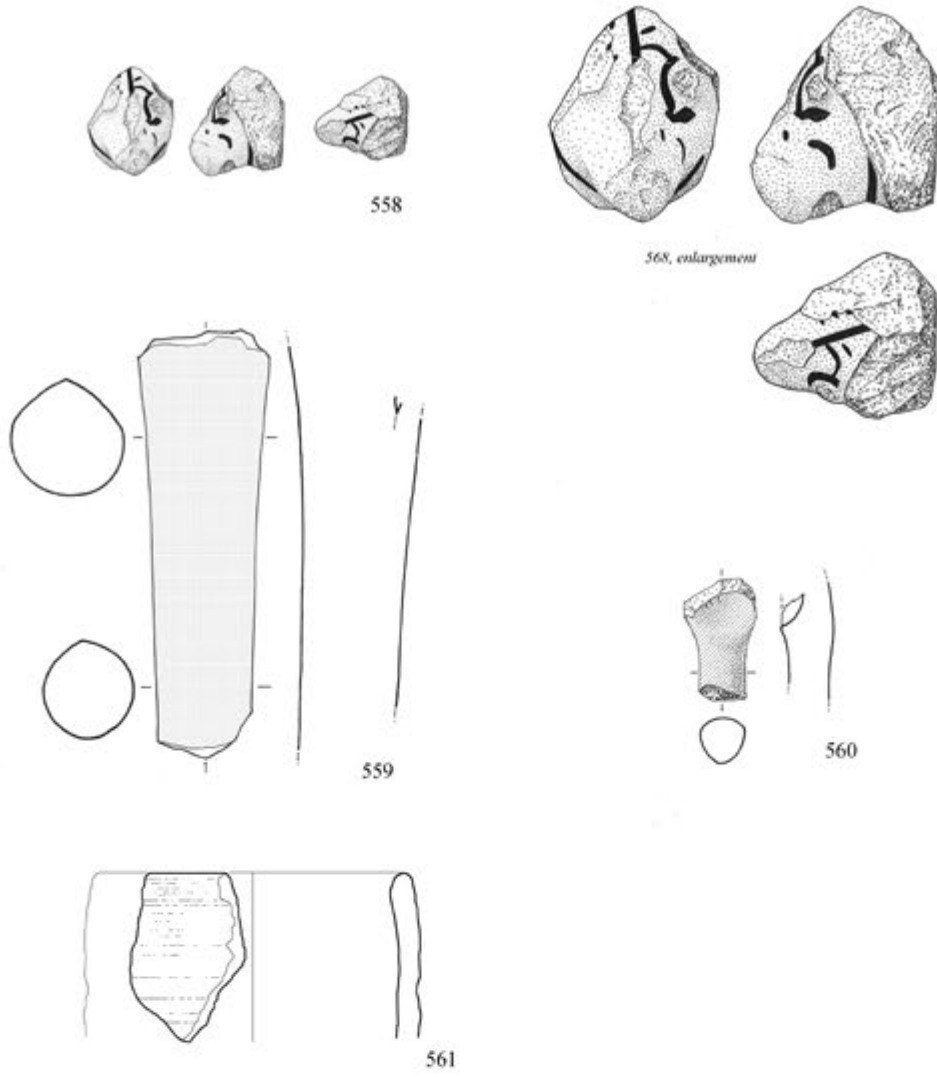


Fig. 30 – Pottery from Uşaklı Höyük.

Figure 31 – Bases

| n. | UKn. | Area | Type | W/Cl | E | ST | Fa | Colour (out.) | Colour (in.) | Colour (sect.) | T | Pl. |
|-----|---------|---------|---------------|--------|----|-----|----|---|--------------------------------|---|---|------------|
| 562 | 12.615 | L9,B6 | B1 | Pt/C | M | 3B | M | P: b. - 5 YR 2.5/1 Ss: v.p.br. - 10 YR 8/3 | r.y. - 7.5 YR 6/6 | r.y. - 7.5 YR 6/6 | W | |
| 563 | 08.804 | F19,a3 | B1 | P/C | M | 1 | M | y.r. - 5 YR 5/8 | y.r. - 5 YR 5/8 | y.r. - 5 YR 5/8 | W | |
| 564 | 12.266 | L9,B4 | B1 | P/C | M | 1 | M | r.y. - 5 YR 6/6 | r.y. - 5 YR 6/6 | r.y. - 5 YR 6/6 | W | |
| 565 | 09.994 | L7,a4 | B1 | P/C | MC | 3So | M | Ss: r.br. - 2.5 YR 5/4 | Ss: r.br. - 2.5 YR 5/4 | O: l.r.br. - 2.5 YR 6/4 I: l.r. - 2.5 YR 6/8 | W | |
| 566 | 08.1258 | L2,B3 | B2 | P/C | M | 1 | M | l.br. - 7.5 YR 6/4 | r.y. - 5 YR 6/6 | O: l.br. - 7.5 YR 6/4 I: r.y. - 5 YR 6/6 | W | |
| 567 | 08.1842 | L3,B4 | B2 | P/C | M | 3 | M | Ss: br. - 7.5 YR 4/3 | br. - 7.5 YR 4/3 | br. - 7.5 YR 4/3 | W | |
| 568 | 08.1574 | L3,B2 | B4 | Rs/C | M | 4B | M | S: we.r. - 10 R 4/4 | S: we.r. - 10 R 4/4 | r. - 2.5 YR 5/6 | W | |
| 569 | 12.285 | L9,B4 | B4 | P/C | M | 2S | M | pi. - 5 YR 7/3 | pi. - 5 YR 7/3 | pi. - 5 YR 7/3 | W | |
| 570 | 08.746 | I19,a1 | B5 | Rs/C-F | F | 4S | M | S: r. - 2.5 YR 5/6 | S: r. - 2.5 YR 5/6 | br. - 7.5 YR 5/3 | W | |
| 571 | 08.1024 | L2,B1 | B5 | G/C | C | 3 | M | Ss: l.g. - 5 YR 7/1 | l.g. - 5 YR 7/1 | l.g. - 5 YR 7/1 | W | |
| 572 | 08.302 | F20,d1 | B5 | Bb/C | F | 4 | M | S: br. - 7.5 YR 5/4 | S: br. - 7.5 YR 5/4 | r.y. - 5 YR 6/6 | W | |
| 573 | 12.1562 | L11,B9 | B5 | Rb/F | MF | 4P | M | S: du.r. - 2.5 YR 3/2 | S: r. - 10 R 4/6 | r.br. - 2.5 YR 5/4 | W | 26.6 |
| 574 | 12.1404 | L11,B7 | B5 | Bb/C-F | MF | 3B | M | Ss: r.y. - 5 YR 6/6 | Ss: r.y. - 5 YR 6/6 | O: r.y. - 7.5 YR 6/6 C: g. - 7.5 YR 6/1 I: r.y. - 7.5 YR 6/6 | W | |
| 575 | 08.346 | F20,b3 | B5 | Rs/F | F | 4P | M | S: r. - 10 R 4/6 | S: r. - 10 R 4/6 | pi. - 5 YR 7/4 | W | |
| 576 | 09.960 | L9,c2 | B5 | Gl/F | F | 5 | M | White and Blue | White and Blue | pi. - 7.5 YR 7/4 | W | 33 |
| 577 | 08.401 | F20, a3 | B5 | P/C | M | 1 | M | br. - 7.5 YR 5/2 | br. - 7.5 YR 5/2 | O: br. - 7.5 YR 5/2 C: r.g. - 10 R 6/1 I: br. - 7.5 YR 5/2 | W | |
| 578 | 08.1075 | L2,B2 | B5 | P/C | M | 3 | M | Ss: v.p.br. - 10 YR 7/3 | Ss: v.p.br. - 10 YR 7/3 | v.p.br. - 10 YR 7/4 | W | |
| 579 | 08.952 | L1,B3 | B6 | Rs/C-F | F | 4S | M | S: l.r.br. - 2.5YR 6/4 | S: l.r.br. - 2.5YR 6/4 | r. - 2.5 YR 5/6 | W | |
| 580 | 09.718 | H15,a1 | B7 | Ys/C | M | 4Bo | M | S: pi. - 2.5 YR 8/3 | S: pi. - 2.5 YR 8/3 | O: l.r.br. - 2.5YR 7/4 C: r.g. - 2.5 YR 6/1 I: l.r.br. - 2.5YR 7/4 | W | 23.7 |
| 581 | 08.556 | H19,a4 | B7 | O/F | FF | 4P | M | S: r. - 2.5 YR 4/8 | S: r. - 2.5 YR 4/8 | r. - 10 R 5/6 | W | |
| 582 | 08.587 | H19,b4 | B10+ 1.J.1 | Bb/F | FF | 2B | M | r.y. - 5 YR 6/8 | r.y. - 5 YR 6/8 | O: r.y. - 5 YR 6/8 C: r.y. - 5 YR 6/6 I: r.y. - 5 YR 6/8 | W | 26.2 29 |

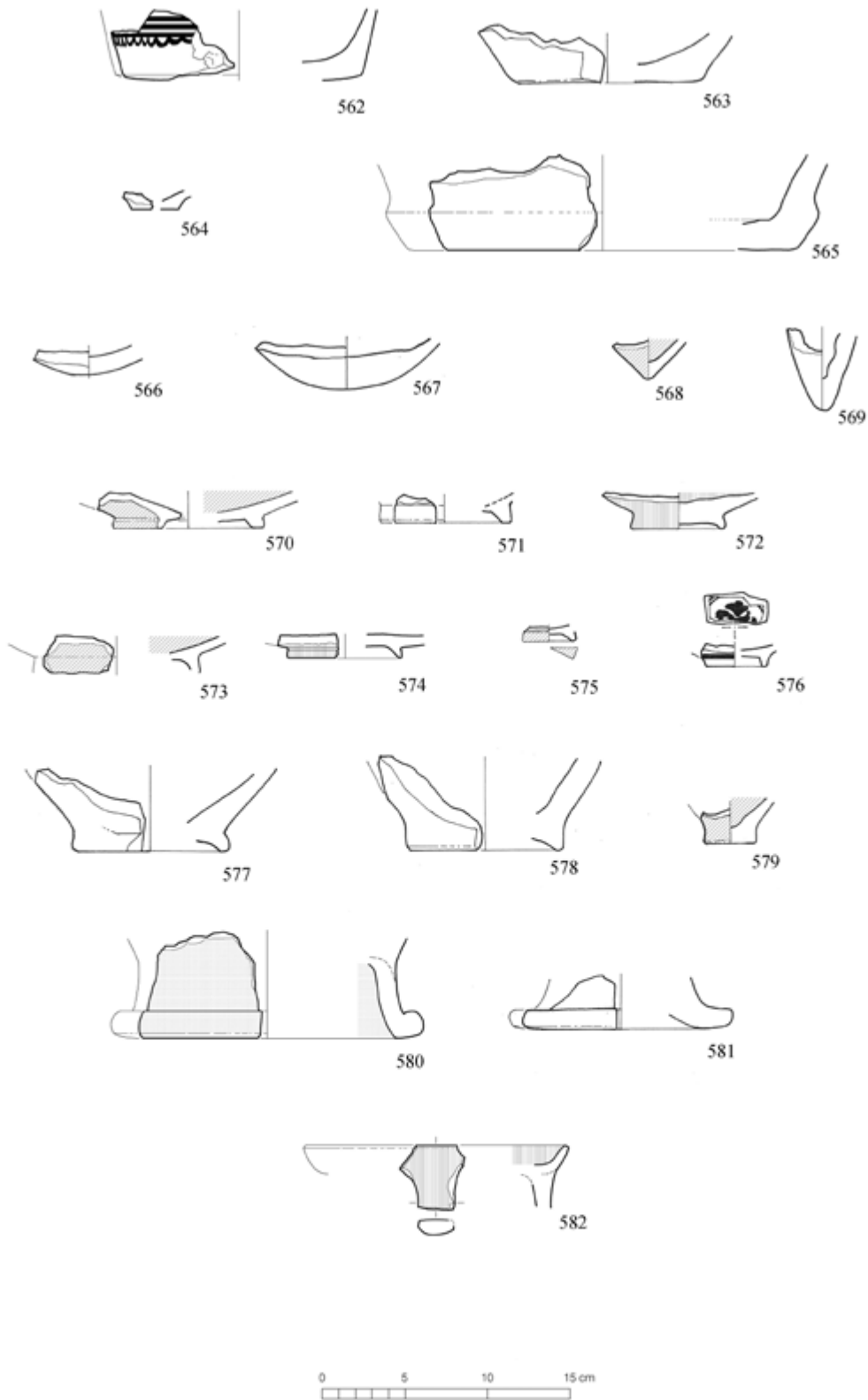


Fig. 31 – Pottery from Uşaklı Höyük.

Figure 32 – Handles

| n. | UKn. | Area | Type | W/Cl | E | ST | Fa | Colour (out.) | Colour (in.) | Colour (sect.) | T | Pl. |
|-----|---------|--------|------|------|----|-----|----|--|-------------------------------------|--|---|------------|
| 583 | 08.816 | F19,b2 | H4 | Rs/C | F | 4B | M | S: r. - 10 R 4/6 | r.y. - 5 YR 6/6 | r.y. - 5 YR 6/6 | | W |
| 584 | 09.1280 | L3,B3 | H1 | Rs/F | FF | 4P | M | S: y.r. - 5 YR 5/6 | S: y.r. - 5 YR 5/6 | l.br - 7.5 YR 6/4 | | W 16.5 |
| 585 | 08.856 | Gen. | H2 | Rs/C | M | 4B | M | S: pi. - 5 YR 7/4 | S: pi. - 5 YR 7/4 | pi. - 5 YR 7/3 | | W |
| 586 | 09.163 | F17,b1 | H3 | Cg/C | M | 2S | M | l.r. - 2.5 YR 6/6, br. - 7.5 YR 5/4 | l.r. - 2.5 YR 6/6, br. - 7.5 YR 5/4 | O: br. - 7.5 YR 5/4 C: g. - GLEY 1 N 6 I: br. - 7.5 YR 5/4 | | W 27.1, 32 |
| 587 | 12.445 | L9,B5B | H3 | P/K | MC | 3 | M | Ss: g. - 5 YR 5/1 | Ss: g. - 5 YR 5/1 | r.y. - 5 YR 6/6 | | W |
| 588 | 08.1903 | L4,B1 | H3 | Pt/C | M | 4P | M | P: v.d.g. - 10 YR 3/1 S: v.p.b. - 10 YR 8/3 | r.y. - 5 YR 6/6 | r.y. - 5 YR 6/6 | | W |
| 589 | 09.1185 | HM | H3 | Cg/C | M | 2S | M | we.r. - 10 R 4/4 | we.r. - 10 R 4/4 | we.r. - 10 R 4/4 | | W 27.7 |
| 590 | 08.1512 | L3,B1 | H4 | Rs/C | M | 4P | M | S: r. - 10 R 4/6 | l.r.br. - 2.5 YR 6/4 | O: d.g. - GLEY 1 N 4 I: l.r.br. - 2.5 YR 6/4 | | W |
| 591 | 08.741 | I19,a2 | H4 | Rs/C | F | 4P | M | S: we.r. - 10 R 4/4 | r.br. - 2.5 YR 5/4 | O: we.r. - 2.5 YR 4/2 I: r.br. - 2.5 YR 5/4 | | W 16.1 |
| 592 | 12.282 | L9,B4 | H4 | Rs/C | M | 4B | M | S: r. - 2.5 YR 5/6 | S: r. - 2.5 YR 5/6 | l.r.br. - 2.5 YR 6/4 | | W |
| 593 | 08.1123 | L2,B2 | H4 | Rs/C | F | 4S | M | S: we.r. - 2.5 YR 4/2 | S: we.r. - 2.5 YR 4/2 | r. - 2.5 YR 5/6 | | W 16.1 |
| 594 | 09.947 | L9,b2 | H5 | Cg/C | MF | 2S | M | r.y. - 7.5 YR 7/6 | r.y. - 7.5 YR 7/6 | O: r.y. - 7.5 YR 7/6 C: l.r. - 10 R 6/6 I: r.y. - 7.5 YR 7/6 | | W 27.3; 32 |
| 595 | 09.172 | F17,d4 | H6 | Cg/C | MF | 2So | M | l.br. - 7.5 YR 6/3 | br. - 7.5 YR 5/2 | O: l.br. - 7.5 YR 6/3 C: l.g. - 7.5 YR 7/1 I: br. - 7.5 YR 5/2 | | W 32 |
| 596 | 09.948 | L9,b2 | H6 | Cg/C | M | 2S | M | l.r. - 2.5 YR 6/6 | l.r. - 2.5 YR 6/6 | O: l.r. - 2.5 YR 6/6 C: r. - 2.5 YR 5/8 I: l.r. - 2.5 YR 6/6 | | W 27.1 |
| 597 | 09.328 | F16,c1 | H6 | P/C | M | 2So | M | br. - 7.5 YR 5/2 | br. - 7.5 YR 5/2 | O: br. - 7.5 YR 5/2 C: g. - 7.5 YR 5/1 I: br. - 7.5 YR 5/2 | | W |
| 598 | 12.651 | L9,B6 | H6 | P/K | M | 1 | M | we.r. - 10 R 4/2 | we.r. - 10 R 4/2 | we.r. - 10 R 4/2 | | W |
| 599 | 08.1203 | L2,B3 | H10 | Rs/C | M | 4B | M | S: r. - 10 R 5/6 | S: r. - 10 R 5/6 | r. - 2.5 YR 5/6 | | W |
| 600 | 09.1218 | D14,b4 | H8 | P/C | MF | 2S | M | r.y. - 5 YR 6/6 | r.y. - 5 YR 6/6 | r.y. - 5 YR 6/6 | | W |

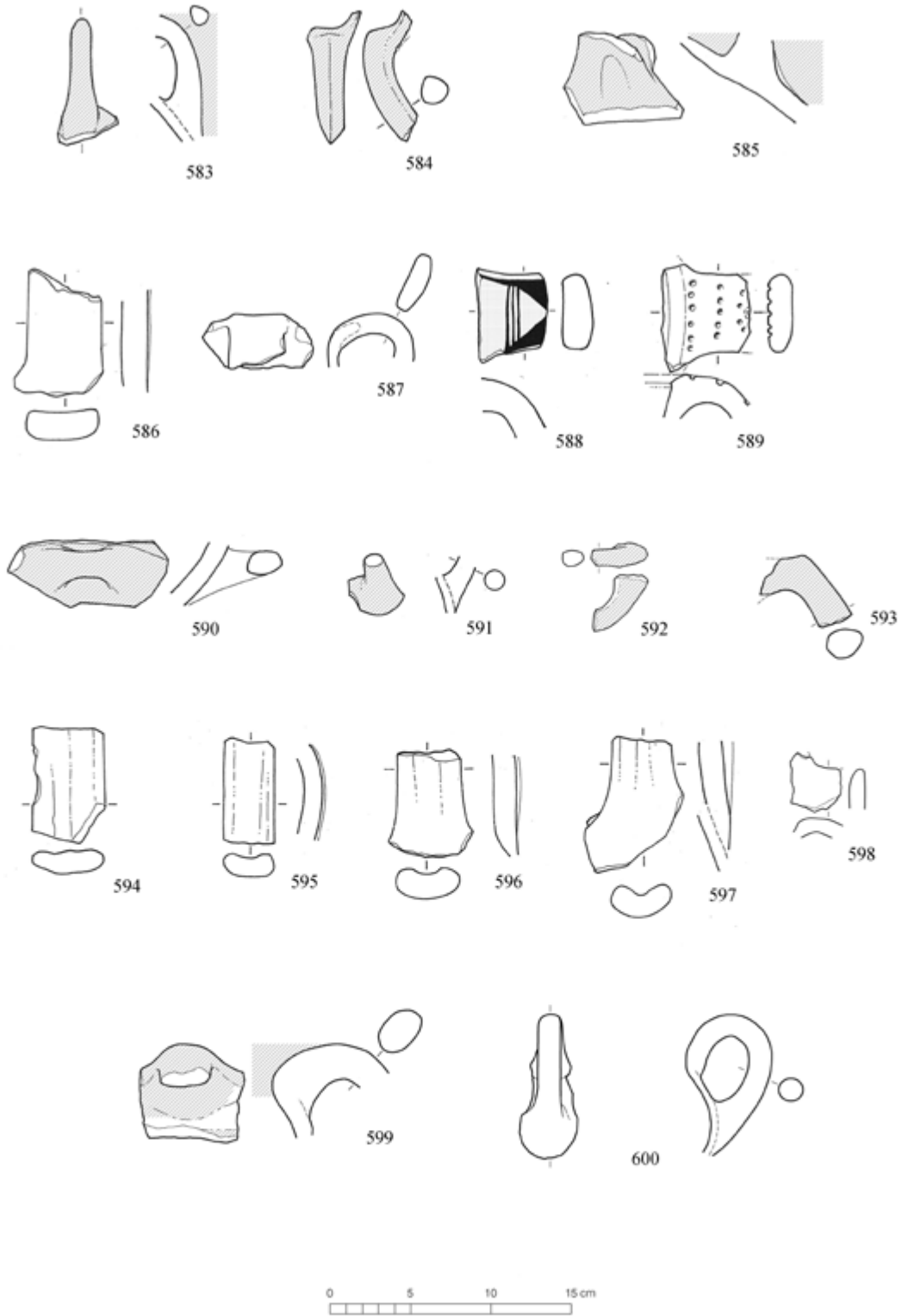


Fig. 32 – Pottery from Uşaklı Höyük.

Figure 33 – Handles

| n. | UKn. | Area | Type | W/Cl | E | ST | Fa | Colour (out.) | Colour (in.) | Colour (sect.) | T | Pl. |
|-----|---------|--------|------|------|----|-------|----|---|---|---|---|------------|
| 601 | 08.853 | TS | H10 | P/C | MF | 2S | M | r.y. - 5 YR 6/6 | r.y. - 5 YR 6/6 | O: r.y. - 5 YR 6/6 C: g. - GLEY1 5/N I: r.y. - 5 YR 6/6 | W | |
| 602 | 08.547 | TS | H10 | Rs/C | M | 4S | M | S: we..r. - 10 R 5/4 | b. - GLEY1 2.5/N | O: l.r. - 2.5 YR 6/6 I: b. - GLEY1 2.5/N | W | |
| 603 | 08.848 | Gen. | H10 | P/C | F | 2S | M | r.y. - 5 YR 6/6 | r.y. - 5 YR 6/6 | r.y. - 5 YR 6/6 | W | |
| 604 | 08.1753 | L3,B3 | H10 | Rs/C | M | 4 | M | S: r.y. - 5 YR 7/6 | S: r.y. - 5 YR 7/6 | r.y. - 7.5 YR 7/6 | W | 20.1 |
| 605 | 12.2200 | L12,B6 | H12 | Pt/C | F | 3Bv-4 | M | P: d.r.br. - 2.5 YR 3/3 Ss: p.y. - 2.5 Y 8/2 | Ss: p.y. - 2.5 Y 8/2 | r.y. - 5 YR 6/6 | H | |
| 606 | 09.230 | G15,c1 | H13 | Cg/C | M | 2S | M | l.r.br - 5 YR 6/4 | l.r.br - 5 YR 6/4 | O: l.r.br - 5 YR 6/4 C: l.r. - 2.5 YR 6/8 I: l.r.br - 5 YR 6/4 | W | 27.1 32 |
| 607 | 09.208 | G15,b1 | H14 | P/C | M | 3So | M | Ss: v.p.br. - 10 YR 8/3 | l.br. - 7.5 YR 6/3 | O: l.br. - 7.5 YR 6/3 C: y.br. - 10 YR 5/4 I: l.br. - 7.5 YR 6/3 | W | |
| 608 | 12.1751 | L10,B9 | H14 | Pt/C | M | 4S | M | P: d.g. - 10 YR 4/1 S: v.p.br. - 10 YR 8/3 | P: d.g. - 10 YR 4/1 S: v.p.br. - 10 YR 8/3 | r.y. - 7.5 YR 8/6 | W | |
| 609 | 09.598 | H13,d4 | H15 | Pt/C | M | 4B | M | P: d.g.b. - 2.5 YR 4/2, we.r. - 2.5 YR 4/2 S: v.p.br. - 10 YR 8/2 | l.r. - 2.5 YR 6/6 | l.r. - 2.5 YR 6/6 | W | 24.3 30 |

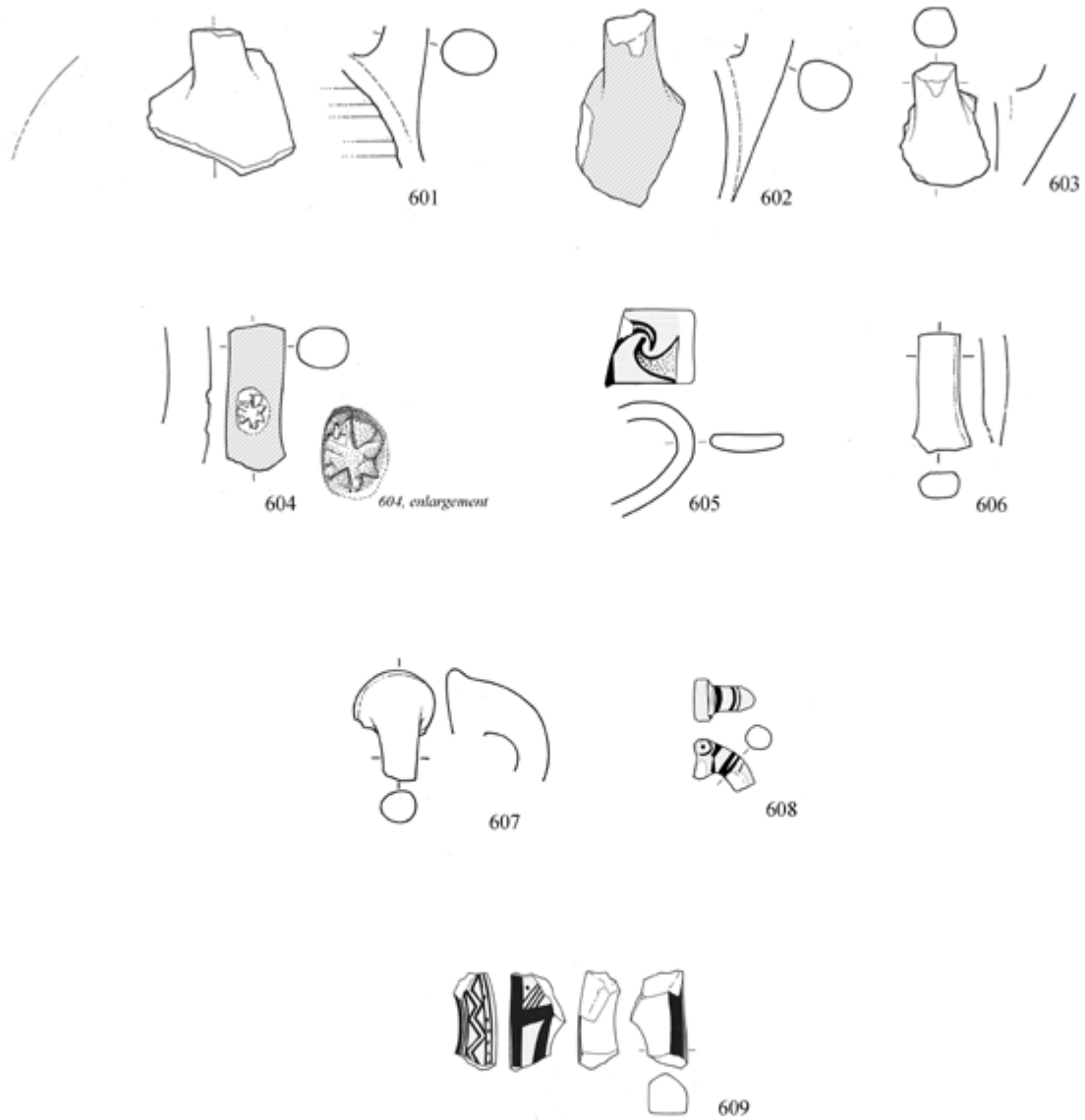


Fig. 33 – Pottery from Uşaklı Höyük.

Figure 34a – Decorated (with painted motifs) body sherds

| n. | UKn. | Area | Type | W/Cl | E | ST | Fa | Colour (out.) | Colour (in.) | Colour (sect.) | T | Pl. |
|-----|---------|------------|------|------|----|------|----|---|--|---|----|------|
| 610 | 08.588 | H19,b4 | 6 | Pt/C | F | 4S | M | P: d.br. - 7.5 YR 3/2 S: v.p.br. - 10 YR 8/2 | S: v.p.br. - 10 YR 8/2 | pi. - 5 YR 7/4 | W | |
| 611 | 08.854 | Gen. | 6 | Pt/C | M | 2P | M | P: br. - 7.5 YR 4/2 s: l.br. - 7.5 YR 6/4 | l.br. - 7.5 YR 6/4 | l.br. - 7.5 YR 6/4 | W | |
| 612 | 10.224 | Gen. | Bsh | Pt/C | MF | 4B | M | P: v.d.g. - 5 YR 3/1 S: v.p.br. - 10 YR 7/4 | l.br. - 7.5 YR 6/4 | l.br. - 7.5 YR 6/4 | W | 23.6 |
| 613 | 10.53 | L7,B3 | Bsh | Pt/C | M | 4P | M | P: r.br. - 2.5 YR 4/4, p.r. - 10 R 6/4 S: l.br. - 7.5 YR 6/3 | S: p.br. - 10 YR 6/3 | r.y. - 5 YR 6/6 | W | 25.1 |
| 614 | 08.2022 | TS | Bsh | Pt/C | M | 4P | M | P: b. - 10 YR 2/1 S: v.p.br. - 10 YR 8/2 | l.r.br. - 5 YR 6/3 | O: r.y. - 5 YR 6/6 I: l.r.br. - 5 YR 6/3 | W | |
| 615 | 08.1908 | L4,B1 | Bsh | Pt/C | F | 4P | M | P: d.r.br. - 5 YR 3/4 S: l.br. - 7.5 YR 6/4 | r. - 2.5 YR 5/6 | r. - 2.5 YR 5/6 | W? | |
| 616 | 12.2101 | L12,B5 | Bsh | Pt/C | M | 3B | M | P: v.d.g. - 5 YR 3/1 Ss: pi. - 5 YR 7/4 | l.r.br. - 5 YR 6/3 | O: r.y. - 5 YR 7/6 I: l.r.br. - 5 YR 6/3 | W | |
| 617 | 08.2199 | Gen. | Bsh | Pt/C | M | 2S | M | P: r. - 2.5 YR 5/6, r.b. - 2.5 YR 2.5/1 s: r.y. - 5 YR 6/6 | P: r. - 2.5 YR 5/6, r.b. - 2.5 YR 2.5/1 s: r.y. - 5 YR 6/6 | r.y. - 5 YR 6/6 | W | 25.3 |
| 618 | 12.923 | L9,B8 | Bsh | Pt/C | MC | 2S | M | P: r.br. - 5 YR 5/4 s: d.g. - 7.5 YR 4/1 | we.r. - 10 R 5/2 | O: d.g. - 7.5 YR 4/1 I: we.r. - 10 R 5/2 | W | |
| 619 | 08.1704 | L3,B3 | Bsh | Pt/C | M | 4P | M | P: v.d.br. - 7.5 YR 2.5/2 S: pi. - 7.5 YR 8/3 | S: pi. - 7.5 YR 8/3 | l.r. - 2.5 YR 6/6 | W | 23.5 |
| 620 | 08.1667 | L3,B3 | Bsh | Pt/C | M | 2P | M | P: d.r.br. - 2.5 YR 3/3 s: l.r.br. - 5 YR 6/4 | l.r.br. - 5 YR 6/4 | O: l.r.br. - 5 YR 6/4 C: r. - 2.5 YR 5/6 I: l.r.br. - 5 YR 6/4 | W | |
| 621 | 12.1704 | Acr. NW | ZA.4 | Pt/C | M | 3S-B | M | P: v.d.g. - 7.5 YR 3/1 s: y.r. - 5 YR 5/6 | y.r. - 5 YR 5/6 | O: y.r. - 5 YR 5/6 C: ly.br. - 2.5 Y 6/4 I: y.r. - 5 YR 5/6 | W | |
| 622 | 12.177 | L9,B3 | Bsh | Pt/C | M | 4P | M | P: we.r. - 10 R 4/4, d.r.g. - 10 R 3/1 S: v.p.br. - 10 YR 8/3 | v.p.br. - 10 YR 8/2 | O: v.p.br. - 10 YR 8/2 C: d.g. - 2.5 Y 4/1 I: v.p.br. - 10 YR 8/2 | W | 24.4 |
| 623 | 12.178 | L9,B3 | Bsh | Pt/C | M | 4P | M | P: we.r. - 10 R 4/4, d.r.g. - 10 R 3/1 S: v.p.br. - 10 YR 8/3 | v.p.br. - 10 YR 8/2 | O: v.p.br. - 10 YR 8/2 C: l.br. - 7.5 YR 6/4 I: v.p.br. - 10 YR 8/2 | W | 24.4 |
| 624 | 08.549 | TS | Bsh | Pt/C | M | 4P | M | P: r.br. - 5 YR 4/4, r.br. - 5 YR 3/2 S: v.p.b. - 10 YR 8/3 | l.r. - 2.5 YR 6/6 | l.r. - 2.5 YR 6/6 | W | 24.7 |
| 625 | 12.494 | L9,B5B | Bsh | Pt/C | M | 4S | M | P: we.r. - 10 R 4/4, d.r.g. - 10 R 3/1 S: v.p.br. - 10 YR 8/3 | y.r. - 5 YR 5/8 | O: br. - 7.5 YR 4/2 I: y.r. - 5 YR 5/8 | W | 24.4 |
| 626 | 09.81 | H16 | Bsh | Pt/C | C | 4S | M | P: l.r.b. - 2.5 YR 6/4, d.r.g. - 2.5 YR 3/1 S: pi. - 7.5 YR 8/3 | y.r. - 5 YR 5/6 | y.r. - 5 YR 5/6 | W | 24.1 |

Figure 34b – Decorated (with incised and applied motifs) body sherds

| n. | UKn. | Area | Type | W/Cl | E | ST | Fa | Colour (out.) | Colour (in.) | Colour (sect.) | T | Pl. |
|-----|---------|--------|------|------|----|-----|----|---------------------|---------------------|---|---|------|
| 627 | 08.1907 | L4,B1 | Bsh | Rs/C | F | 4 | M | S: r. - 10 R 5/6 | r.br. - 5 YR 5/4 | r.br. - 5 YR 5/4 | W | 20.1 |
| 628 | 08.1243 | L2,B3 | Bsh | Rs/C | F | 4S | M | S: we.r. - 10 R 5/4 | y.r. - 5 YR 5/6 | y.r. - 5 YR 5/6 | W | 20.1 |
| 629 | 12.484 | L9,B5B | Bsh | Rs/C | M | 4B | M | S: r. - 10 R 4/8 | d.r.g. - 2.5 YR 4/1 | O: l.r. - 2.5 YR 6/8 I: d.r.g. - 2.5 YR 4/1 | W | |
| 630 | 12.804 | L9,B8 | Bsh | Rs/C | M | 4S | M | S: we.r. - 10 R 4/4 | r. - 2.5 YR 5/6 | O: r. - 2.5 YR 5/6 C: d.g. - 7.5 YR 4/1 I: r. - 2.5 YR 5/6 | W | 20.2 |
| 631 | 09.1256 | HM | Bsh | Rs/C | MF | 4Bv | M | S: r. - 10 R 4/6 | pi.g. - 7.5 YR 6/2 | O: p.r. - 10 R 6/4 C: l.br. - 7.5 YR 6/4 I: pi.g. - 7.5 YR 6/2 | W | 20.1 |
| 632 | 08.858 | L1,B1 | Bsh | Rs/C | M | 4 | M | S: r. - 10 R 5/6 | r.y. - 5 YR 6/6 | O: r.y. - 5 YR 6/6 C: d.g. - GLEY 1 N 4 I: r.y. - 5 YR 6/6 | W | 20.1 |
| 633 | 09.8 | F19,c3 | Bsh | Rs/C | MF | 4 | M | S: r. - 10 R 5/6 | l.br. - 7.5 YR 6/4 | O: l.br. - 7.5 YR 6/4 C: br. - 7.5 YR 5/2 I: l.br. - 7.5 YR 6/4 | W | 20.1 |
| 634 | 08.432 | G19,a4 | Bsh | Rs/C | F | 4S | M | S: we.r. - 10 R 4/4 | v.d.g. - GLEY 1 3/N | v.d.g. - GLEY 1 3/N | W | |

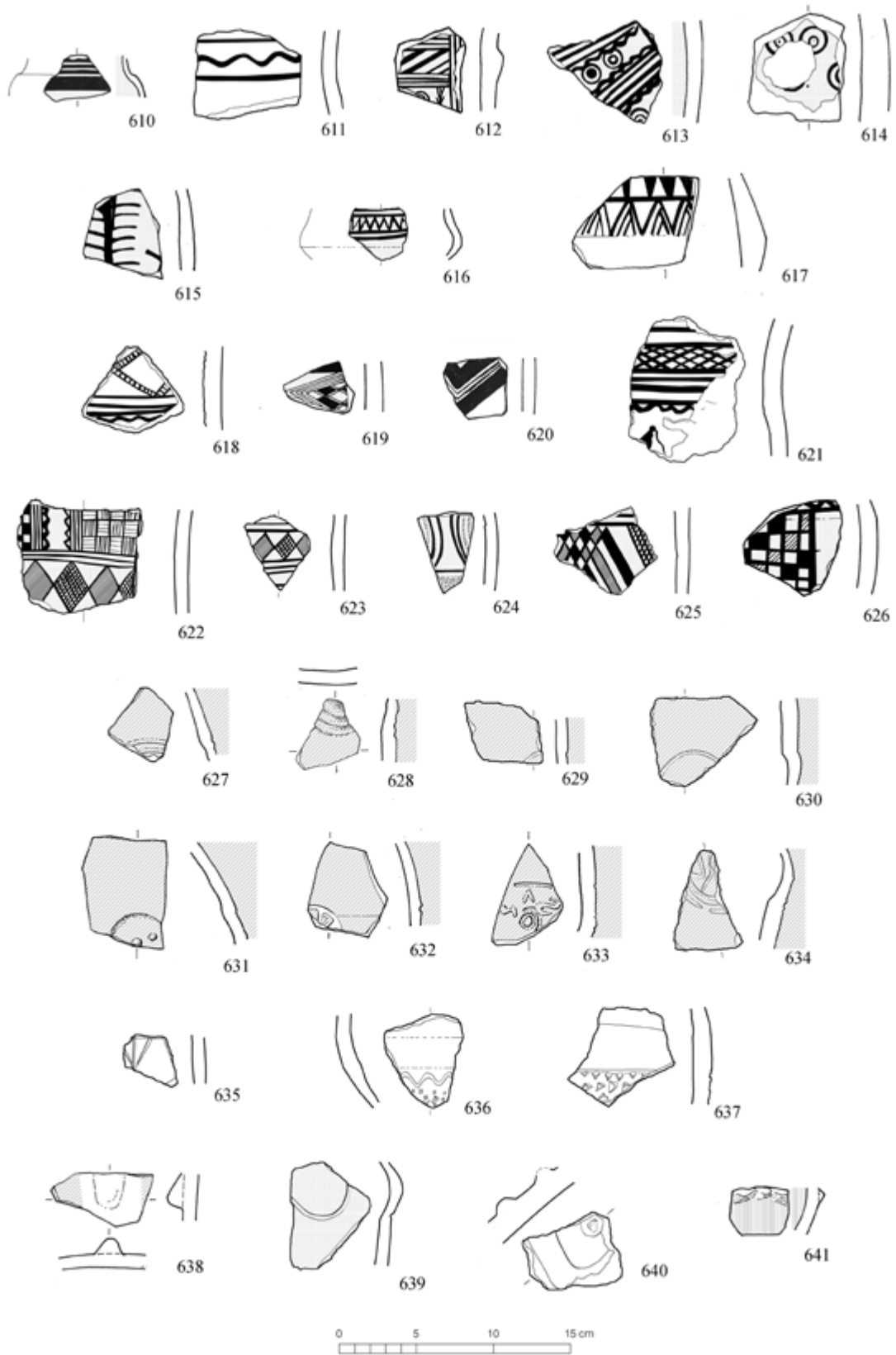


Fig. 34 – Pottery from Uşaklı Höyük.

| n. | UKn. | Area | Type | W/Cl | E | ST | Fa | Colour (out.) | Colour (in.) | Colour (sect.) | T | Pl. |
|-----|---------|--------|------|------|---|-------|----|------------------------|---------------------|--|---|------|
| 635 | 09.305 | F16,b3 | Bsh | P/C | M | 3B | M | Ss: l.br. - 7.5 YR 6/4 | l.r. - 2.5 YR 6/6 | l.r. - 2.5 YR 6/8 | W | 20.3 |
| 636 | 12.1514 | L11,B8 | Bsh | P/C | M | 3 | M | Ss: r. - 2.5 YR 5/6 | we.r. - 10 R 4/4 | we.r. - 10 R 4/4 | W | 27.5 |
| 637 | 12.1513 | L11,B8 | Bsh | G/C | M | 3B | M | Ss: v.d.g. - 2.5 Y 3/1 | v.d.g. - 2.5 Y 3/1 | O: v.d.g. - 2.5 Y 3/1 C: d.g. - 10 YR 4/1 I: v.d.g. - 2.5 Y 3/1 | W | 21.5 |
| 638 | 08.1150 | L2,B3 | Bsh | Rs/C | M | 4S | M | S: we.r. - 10 R 4/4 | g. - GLEY 1 N 5 | O: y.r. - 5 YR 5/6 I: g. - GLEY 1 N 5 | W | |
| 639 | 08.762 | F19,c4 | Bsh | Ys/C | F | 4B | M | S: pi. - 5 YR 7/4 | l.r. - 2.5 YR 6/8 | O: g. - GLEY 1 N 5, l.r. - 2.5 YR 6/8; C: gr.g. - GLEY 1 10 Y 6/1 I: l.r. - 2.5 YR 6/8 | W | 26.6 |
| 640 | 12.290 | L9,B4 | Bsh | P/S | M | 1 | M | r. - 2.5 YR 5/6 | r. - 2.5 YR 5/6 | O: r. - 2.5 YR 5/6 C: r.br. - 5 YR 4/3 I: r. - 2.5 YR 5/6 | W | |
| 641 | 08.2210 | I9,c1 | Bsh | P/C | M | 4P+3P | M | S: v.p.br. - 10 YR 8/3 | v.p.br. - 10 YR 7/3 | O: v.p.br. - 10 YR 7/3 C: v.d.g. - GLEY 1 N 3 I: v.p.br. - 10 YR 7/3 | H | 15.6 |

Figure 35 – Hand-made sherds (various types)

| n. | UKn. | Area | Type | W/Cl | E | ST | Fa | Colour (out.) | Colour (in.) | Colour (sect.) | T | Pl. |
|-----|---------|---------|--------|------|----|-------|----|--|--|--|---|-------|
| 642 | 08.1519 | L3,B1 | 11 | P/C | M | 2B | M | r.br. - 5 YR 5/4 | r.br. - 5 YR 5/4 | r.br. - 5 YR 5/4 | H | 15.9 |
| 643 | 09.790 | H15,d1 | 2A | Rs/C | M | 4Bo | V | S: r. - 10 R 5/8 | S: r. - 10 R 5/8 | O: r. - 10 R 5/6 C: v.d.g. GLEY 1 N 3 I: r. - 10 R 5/6 | H | 15.5 |
| 644 | 09.890 | E16,a2 | 2A | P/C | M | 3Bo | MV | Ss: r.br. - 5 YR 5/4 | Ss: r.br. - 2.5 YR 5/4 | O: y.r. - 5 YR 4/6 C: r. - 10 R 5/6 I: y.r. - 5 YR 4/6 | H | |
| 645 | 12.661 | L9,B7 | 2A | Rs/C | MC | 4B | MV | S: r. - 2.5 YR 4/6 | S: r. - 2.5 YR 4/6 | ry. - 5 YR 6/8 | H | |
| 646 | 12.108 | L9,B3 | 2A.16 | Rs/F | M | 4Bo | M | S: r. - 10 R 5/6 | S: r. - 10 R 5/6 | l.br. - 7.5 YR 6/4 | H | |
| 647 | 12.107 | L9,B3 | 2A | Rs/C | M | 4Bo | V | S: we.r. - 10 R 5/4 | S: we.r. - 10 R 5/4 | r. - 2.5 YR 5/6 | H | 15.8 |
| 648 | 09.1211 | D14,a2 | 2A.7 | P/C | MC | 1 | M | br. - 7.5 YR 5/3 | d.g. - 7.5 YR 4/1 | O: br. - 7.5 YR 5/3 I: d.g. - 7.5 YR 4/1 | H | 15.10 |
| 649 | 09.1169 | L-1,B5A | 2A.15b | P/C | M | 2B | VM | l.r. - 2.5 YR 6/6, l.r.br. - 5 YR 6/4 | l.r. - 2.5 YR 6/6, l.r.br. - 5 YR 6/4 | O: l.r.br. - 5 YR 6/4 C: ry. - 5 YR 6/6 I: l.r.br. - 5 YR 6/4 | H | 15.5 |
| 650 | 08.883 | L1,B2 | 2A.15b | Rs/C | M | 4Bo+V | M | S: r. - 10 R 5/6 | S: r. - 10 R 5/6 | O: r.br. - 2.5 YR 5/4 C: l.br. - 7.5 YR 6/3 I: r.br. - 2.5 YR 5/4 | H | 15.9 |
| 651 | 08.2195 | Gen. | 2A.15b | Rs/C | M | 4S | M | S: pi. - 5 YR 7/4 | S: pi. - 5 YR 7/4 | l.r. - 2.5 YR 6/8 | H | 15.9 |
| 652 | 10.109 | L5,B6 | 2B.5a | P/C | M | 3B | MV | Ss: r.br. - 5 YR 5/4 | Ss: r. - 2.5 YR 5/6 | ry. - 5 YR 6/8 | H | 15.2 |
| 653 | 12.1140 | L11,B4 | 2B.3 | Rs/C | MC | 4Bo | MV | S: r. - 2.5 YR 5/8 | S: r. - 10 R 5/6 | ry. - 5 YR 6/8 | H | 15.7 |
| 654 | 10.46 | L7,B3 | 2B.4a | Rs/C | M | 4B | V | S: l.r.br. - 2.5 YR 6/4 | S: l.r. - 10 R 6/6 | O: v.d.g. - 5 YR 3/1 I: r.br. - 5 YR 5/4 | H | 15.2 |
| 655 | 08.846 | F19,a1 | 2B.4 | Rs/C | M | 4B | M | S: w.r. - 10 R 4/4 | S: w.r. - 10 R 4/4 | O: r.br. - 5 YR 5/3 C: d.g. - GLEY 1 N 4 I: r.br. - 5 YR 5/3 | H | 15.4 |
| 656 | 12.1927 | L12,B4 | 2B.4 | Rs/C | M | 4B | M | S: br. - 7.5 YR 5/3 | S: br. - 7.5 YR 5/3 | br. - 10 YR 4/3 | H | |
| 657 | 12.1549 | L11,B9 | 2B.4 | Rs/C | MC | 4 | M | S: r. - 10 R 5/8 | S: r. - 10 R 5/8 | s.br. - 7.5 YR 5/6 | H | |
| 658 | 12.663 | L9,B7 | 2C | Rs/C | MC | 4 | MV | S: r. - 2.5 YR 4/8 | S: r. - 2.5 YR 4/8 | y.r. - 5 YR 5/6 | H | 15.4 |
| 659 | 09.1020 | L10,c3 | 2C.x | P/C | MC | 2S | M | pi. - 7.5 YR 7/4 | pi. - 7.5 YR 7/4 | O: pi. - 7.5 YR 7/4 C: r. - 2.5 YR 5/6 I: pi. - 7.5 YR 7/4 | H | 15.10 |
| 660 | 09.1208 | D14,a4 | 2C.x | P/C | M | 3 | MV | Ss: we.r. - 10 R 5/4 | ry. - 5 YR 6/6 | O: l.r.br. - 2.5 YR 6/4 C: l.r. - 2.5 YR 6/8, v.d.g. - GLEY 1 N 3 I: ry. - 5 YR 6/6 | H | 15.5 |
| 661 | 09.247 | G15,d1 | 2C.x | P/C | MC | 2Bo | M | r.br. - 2.5 YR 4/4 | r.br. - 2.5 YR 4/4 | O: r.br. - 2.5 YR 4/4 C: r. - 2.5 YR 5/6 I: r.br. - 2.5 YR 4/4 | H | 15.5 |
| 662 | 12.228 | L9,B4 | 5A | Rs/C | MC | 4 | M | S: r. - 10 R 4/6 | S: r. - 10 R 4/6 | r. - 2.5 YR 5/6 | H | |
| 663 | 12.226 | L9,B4 | 5A | P/C | C | 3B | M | Ss: l.r. - 10 R 7/8 | l.r. - 10 R 6/8 | O: l.r. - 10 R 6/8 C: r.br. - 2.5 YR 5/3 I: l.r. - 10 R 6/8 | H | |

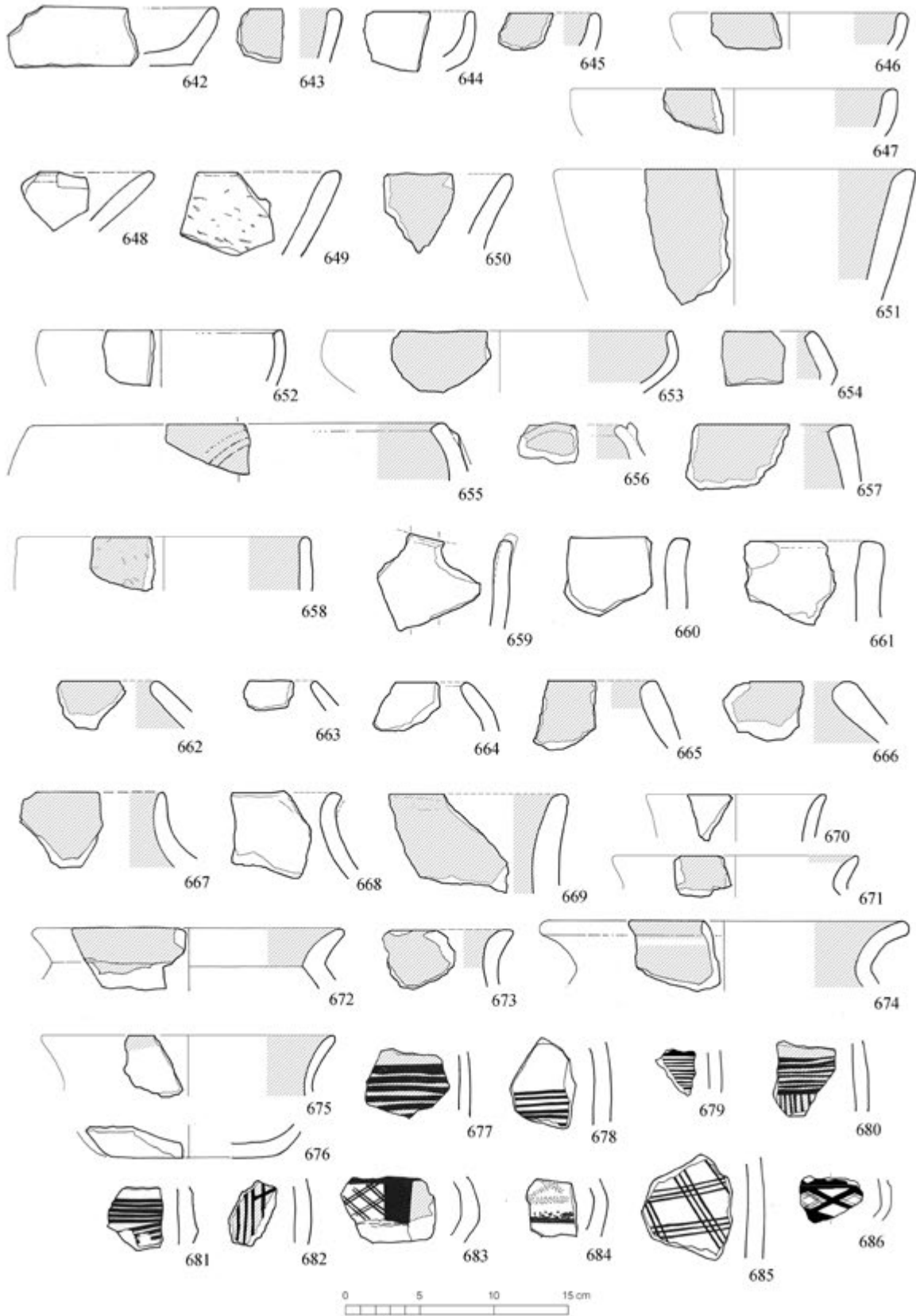


Fig. 35 – Pottery from Uşaklı Höyük.

| n. | UKn. | Area | Type | W/Cl | E | ST | Fa | Colour (out.) | Colour (in.) | Colour (sect.) | T | Pl. |
|-----|---------|--------|-------|--------|----|-----|-----|--|--|---|-----|--------------|
| 664 | 12.194 | L9,B4 | 5A | P/C | C | 3S | MV | Ss: pi. - 7.5 YR 8/4 | l.r. - 2.5 YR 6/8 | O: l.r. - 2.5 YR 6/8 C: ry. - 7.5 YR 7/6 I: l.r. - 2.5 YR 6/8 | H | |
| 665 | 12.1924 | L12,B4 | 5A | Rs/C | M | 4S | MV | S: r. - 10 R 5/6 | S: ry. - 5 YR 6/6 | r.br. - 2.5 YR 4/4 | H | |
| 666 | 12.482 | L9,B5B | 5A | Rs/S-K | C | 4 | MV | S: r. - 10 R 4/6 | r. - 10 R 5/8 | O: r. - 10 R 5/8 C: d.r.g. - 10 R 4/1 I: r. - 10 R 5/8 | H | |
| 667 | 09.892 | E16,a2 | 6A | Rs/C | M | 4B | M | S: r. - 10 R 5/6 | S: r. - 10 R 5/6 | O: l.br. - 7.5 YR 6/4 C: br. - 7.5 YR 5/4 I: ry. - 5 YR 6/6 | H | 15.5 |
| 668 | 08.280 | K19,d2 | 6A | P/C | M | 3B | M | Ss: pi. - 7.5 YR 7/4 | Ss: pi. - 7.5 YR 7/4 | r. - 2.5 YR 5/8 | H | |
| 669 | 12.362 | L9,B5A | 6B | Rs/S | MC | 4Bb | MV | S: r. - 10 R 5/6 | S: r. - 10 R 5/6 | O: pi. - 7.5 YR 7/4 C: g. - 7.5 YR 6/1 I: pi. - 7.5 YR 7/4 | H | |
| 670 | 12.447 | L9,B5B | 6B | G/C | MF | 2P | M | g. - 2.5 Y 6/1 | g. - 2.5 Y 6/1 | g. - 2.5 Y 6/1 | W/H | |
| 671 | 09.1026 | L11,a4 | 6B.1 | Rs/C | M | 4Bo | M+V | S: r. - 10 R 4/6 | S: r. - 10 R 4/6 | O: pi. - 7.5 YR 7/4 C: br. - 7.5 YR 5/4 I: pi. - 7.5 YR 7/4 | H | |
| 672 | 08.1128 | L2,B2 | 6A.1b | Rs/C | M | 4S | M | S: r. - 10 R 5/6 | S: r. - 10 R 5/6 | we.r. - 10 R 5/4 | H | 15.9 |
| 673 | 12.800 | L9,B8 | 6C.8 | Rs/C | M | 4B | M | S: we.r. - 10 R 4/4 | r.br. - 5 YR 5/4 | O: r.br. - 5 YR 5/4 C: d.g. - 5 YR 4/1 I: r.br. - 5 YR 5/4 | H | |
| 674 | 08.1231 | L2,B3 | 6C.6a | Rs/C | M | 4S | M | S: l.r. - 10 R 6/6 | S: l.r. - 10 R 6/6 | r.br. - 5 YR 5/4 | H | 15.9 |
| 675 | 12.135 | L9,B3 | 6C.8 | Rs/C | M | 4Bb | MV | S: r. - 2.5 YR 5/6 | S: r. - 2.5 YR 5/6 | y.r. - 5 YR 5/6 | H | 15.8 |
| 676 | 08.564 | H19,a3 | B1 | P/C | M | 2B | M | we.r. - 10 R 4/4, br. - 7.5 YR 5/3 | we.r. - 10 R 4/4, br. - 7.5 YR 5/3 | O: br. - 7.5 YR 5/3 C: g. - 5 YR 6/1 I: br. - 7.5 YR 5/3 | H | 15.9 |
| 677 | 09.1212 | D14,a2 | Bsh | C/C | M | 4B | MV | P: p.r. - 10 R 6/3 S: r. - 10 R 4/8 | l.r.br. - 5 YR 6/4 | O: g.br. - 2.5 Y 5/6 C: l.o.br. - 2.5 Y 5/6, r.b. - 2.5 YR 2.5/1 I: l.r.br. - 5 YR 6/4 | H | 15.1 28 |
| 678 | 08.1695 | L3,B3 | Bsh | C/C | M | 2B | M | P: d.r.g. - 5 YR 4/2 s: r.br. - 5 YR 5/4 | r.br. - 5 YR 5/4 | O: r.br. - 5 YR 5/4 C: d.g. - 5 YR 4/1 I: r.br. - 5 YR 5/4 | H | 15.1 |
| 679 | 12.1265 | L11,b5 | Bsh | C/C | M | 4S | MV | P: br. - 7.5 YR 4/2 S: ry. - 5 YR 6/6 | l.br. - 7.5 YR 6/4 | O: l.br. - 7.5 YR 6/4 C: d.g. - 2.5 Y 4/1 I: l.br. - 7.5 YR 6/4 | H | |
| 680 | 08.2203 | F20,a4 | Bsh | C/C | M | 4P | M | P: bl.b. - 5 PB 2.5/1 S: r. - 10 R 5/6 | l.r. - 10 R 6/6 | l.r. - 10 R 6/6 | H | 15.1 |
| 681 | 08.1133 | TS | Bsh | C/C | M | 4S | M | P: b. - 7.5 YR 2.5/1 S: pi. - 7.5 YR 7/4 | r.br. - 2/5 YR 4/3 | O: r.br. - 2.5 YR 4/3 C: b. - GLEY1 2.5/N I: r.br. - 2.5 YR 4/3 | H | 15.1 28 |
| 682 | 12.1438 | L11,B7 | Bsh | C/C | M | 4Bb | M | P: r.g. - 2.5 YR 5/1 S: r. - 10 R 5/6 | r. - 2.5 YR 5/8 | O: r. - 2.5 YR 5/8 C: r.g. - 2.5 YR 5/1 I: r. - 2.5 YR 5/8 | H | |
| 683 | 08.382 | F19,b4 | 2B.4a | C/C | M | 4B | M | P: l.br. - 7.5 YR 6/3 S: l.br. - 7.5 YR 6/4 | ry. - 7.5 YR 6/6 | ry. - 7.5 YR 6/6 | H | 15.1 |
| 684 | 10.156 | L6,B7 | 2 | C/C | MF | 4B | M | P: v.d.g. - 7.5 YR 3/1 S: r. - 10 R 5/8 | l.r. - 2.5 YR 7/6 | O: l.r.br. - 5 YR 6/4 I: r. - 2.5 YR 5/6 | H | 15.1 15.2 |
| 685 | 09.801 | H15,d1 | Bsh | C/C | M | 2Bo | VM | P: we.r. - 2.5 YR 4/2 s: r.br. - 5 YR 5/4 | P: we.r. - 2.5 YR 4/2 s: r.br. - 5 YR 5/4 | O: r.br. - 5 YR 5/4 C: g. - 5 YR 5/1 I: r.br. - 5 YR 5/4 | H | 15.1 28 |
| 686 | 12.617 | L9,B6 | Bsh | C/C | MC | 3B | M | P: b. - 10 YR 2/1 s: l.br. - 7.5 YR 6/4 | l.br. - 7.5 YR 6/4 | O: l.br. - 7.5 YR 6/4 C: ry. - 5 YR 7/6 I: l.br. - 7.5 YR 6/4 | H? | 15.4 |

Figure 36 – Fragmentary tiles (tegulae and imbrices)

| n. | UKn. | Area |
|-----|---------|--------|
| 687 | 08.516 | |
| 688 | 08.85 | J19 |
| 689 | 08.nn | H18,a3 |
| 690 | 08.nn | F14,a4 |
| 691 | 08.890 | |
| 692 | 08.1044 | |

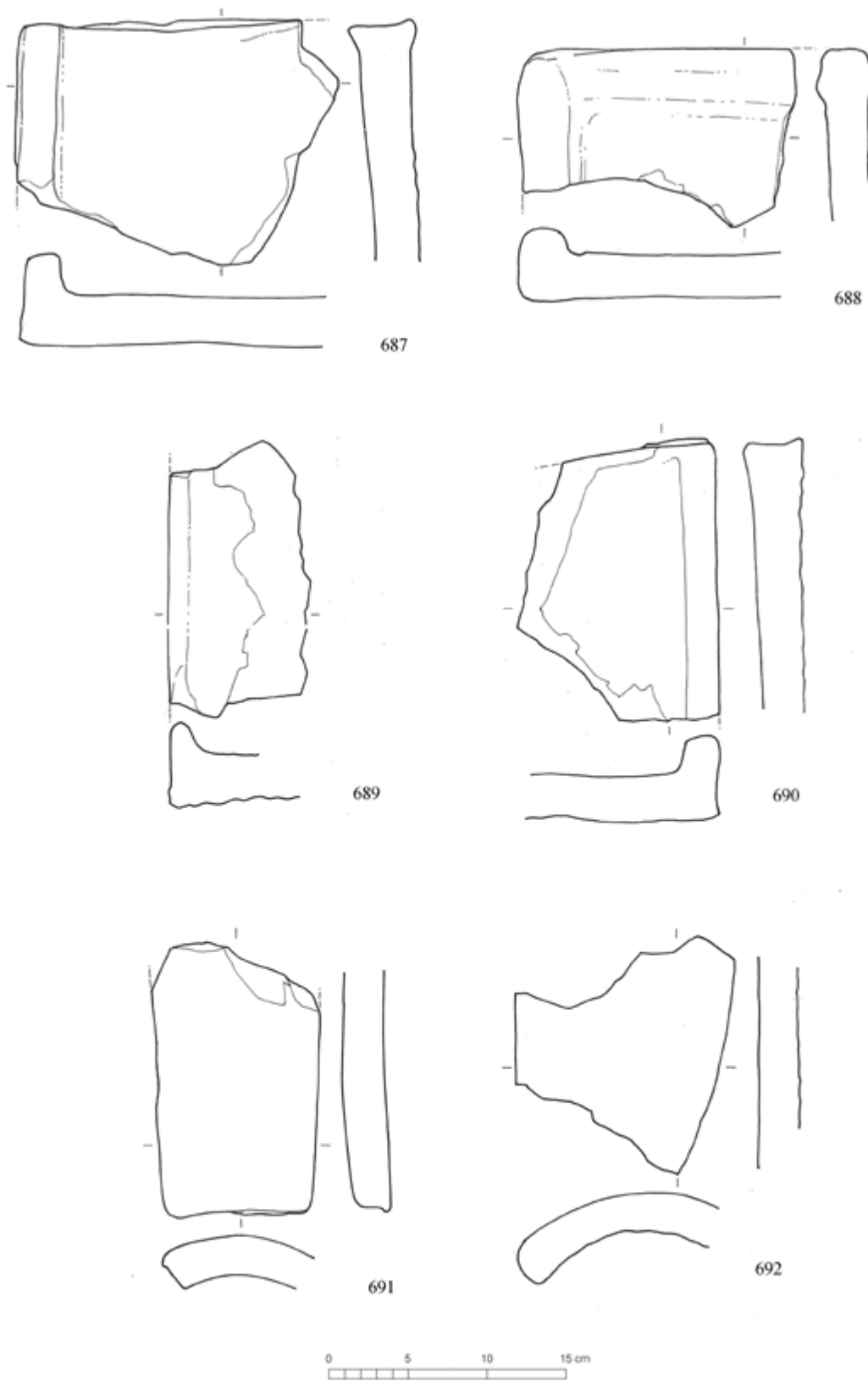


Fig. 36 – Tiles from Uşaklı Höyük.

Figure 37 – SS-03 Taşlık Höyük

| n. | SS3n. | Type | W/Cl | E | ST | Fa | Colour (out.) | Colour (in.) | Colour (sect.) | T | Pl. |
|-----|---------|---------|------|---|----------------|----|--|--|--|---|-----|
| 693 | 08.5 | 1A.1 | P/C | M | 3B | M | Ss: r.y. - 7.5 YR 6/6 | Ss: r.y. - 7.5 YR 6/6 | O: l.br. - 7.5 YR 6/4 C: g. - 7.5 YR 6/1 I: l.br. - 7.5 YR 6/4 | H | 39 |
| 694 | 08.2 | 2A.2 | P/C | M | 2B | V | br. - 10 YR 4/3 | br. - 10 YR 4/3 | O: br. - 10 YR 4/3 C: d.g. - 7.5 YR 4/1 I: br. - 10 YR 4/3 | H | 39 |
| 695 | 08.6 | 2A.5 | Rs/C | M | 4 | M | S: r. - 10 R 4/6 | S: r. - 10 R 4/6 | l.r. - 2.5 YR 7/8 | H | 39 |
| 696 | 08.4 | 2A.5 | P/C | M | 2B | M | r.br. - 2.5 YR 4/3, g. - 5 YR 5/1 | r.b. - 2.5 YR 4/3, g. - 5 YR 5/1 | O: r.br. - 2.5 YR 4/3 C: r.g. - 2.5 YR 5/1 I: r.br. - 2.5 YR 4/3 | H | 39 |
| 697 | 08.3 | 2A.7 | Rs/C | M | 4B | M | S: r. - 2.5 YR 5/6 | S: r. - 2.5 YR 5/6 | l.r. - 10 R 6/6 | H | 39 |
| 698 | 08.7 | 2A.5 | P/C | M | 2B | M | v.d.g. - GLEY 1 N 3, r.br. - 2.5 YR 4/3 | v.d.g. - GLEY 1 N 3, r.br. - 2.5 YR 4/3 | O: v.d.g. - GLEY 1 N 3 C: d.g. - GLEY 1 N 4 I: v.d.g. - GLEY 1 N 3 | H | |
| 699 | 08.16+9 | 2A.5 | Rs/C | M | 4 | M | S: r. - 10 R 4/6 | S: r. - 10 R 4/6 | r. - 2.5 YR 5/6 | H | 39 |
| 700 | 08.21 | 2A.5 | Rs/C | M | 4B | M | S: l.br. - 7.5 YR 6/4 | S: l.r. - 10 R 7/6 | l.r.br. - 5 YR 6/4 | H | 39 |
| 701 | 08.12 | 6B | P/C | M | 2B | V | r.br. - 5 YR 5/4, d.r.br. - 5 YR 3/3 | r.br. - 5 YR 5/4, d.r.br. - 5 YR 3/3 | O: d.r.br. - 5 YR 3/3 C: r.br. - 2.5 YR 4/3, v.d.g. - GLEY 1 N 3 I: d.r.br. - 5 YR 3/3 | H | 39 |
| 702 | 08.11 | 2C.x | P/C | M | 2B | M | y.r. - 5 YR 5/6 | y.r. - 5 YR 5/6 | y.r. - 5 YR 5/6 | H | 39 |
| 703 | 08.10 | 5A.10 | G/K | M | 2Bv+b (radial) | M | br. - 10 YR 4/3, g. - 5 YR 5/1 | br. - 10 YR 4/3, v.d.g. GLEY 1 N 3 | O: g. - 5 YR 5/1 I: v.d.g. GLEY 1 N 3 | H | 39 |
| 704 | 08.13 | Bsh | Bb | M | 2B | M | br. - 7.5 YR 5/2, d.g. - 7.5 YR 4/1 | v.d.g.br. - 10 YR 3/2, br. - 7.5 YR 4/2 | O: d.g. - 7.5 YR 4/1 C: br. - 7.5 YR 4/2, g. - 7.YR 6/1 I: v.d.g.br. - 10 YR 3/2 | H | 39 |
| 705 | 08.18 | andiron | | M | 3S | M | Ss: l.r.br. - 5 YR 6/4 | Ss: l.r.br. - 5 YR 6/4 | y.r. - 5 YR 5/6 | W | 39 |
| 706 | 08.22 | 2A.18a | P/C | M | 4S | M | S: l.br. - 7.5 YR 6/4 | S: l.br. - 7.5 YR 6/4, pi. - 7.5 YR 7/4 | O: l.br. - 7.5 YR 6/3 C: we.r. - 10 R 5/4 I: l.br. - 7.5 YR 6/3 | W | 39 |
| 707 | 08.42 | 2A.29a | Ys/C | M | 4B | M | S: l.br. - 7.5 YR 6/4 | S: l.br. - 7.5 YR 6/4 | r.br. - 2.5 YR 4/3 | W | 39 |
| 708 | 08.19 | H10 | Pt/C | M | 2B | M | S: r. - 10 R 4/8 s: l.r. - 10 R 7/6 | r.g. - 10 R 6/1 | O: l.r. - 10 R 7/6 I: r.g. - 10 R 6/1 | H | 39 |

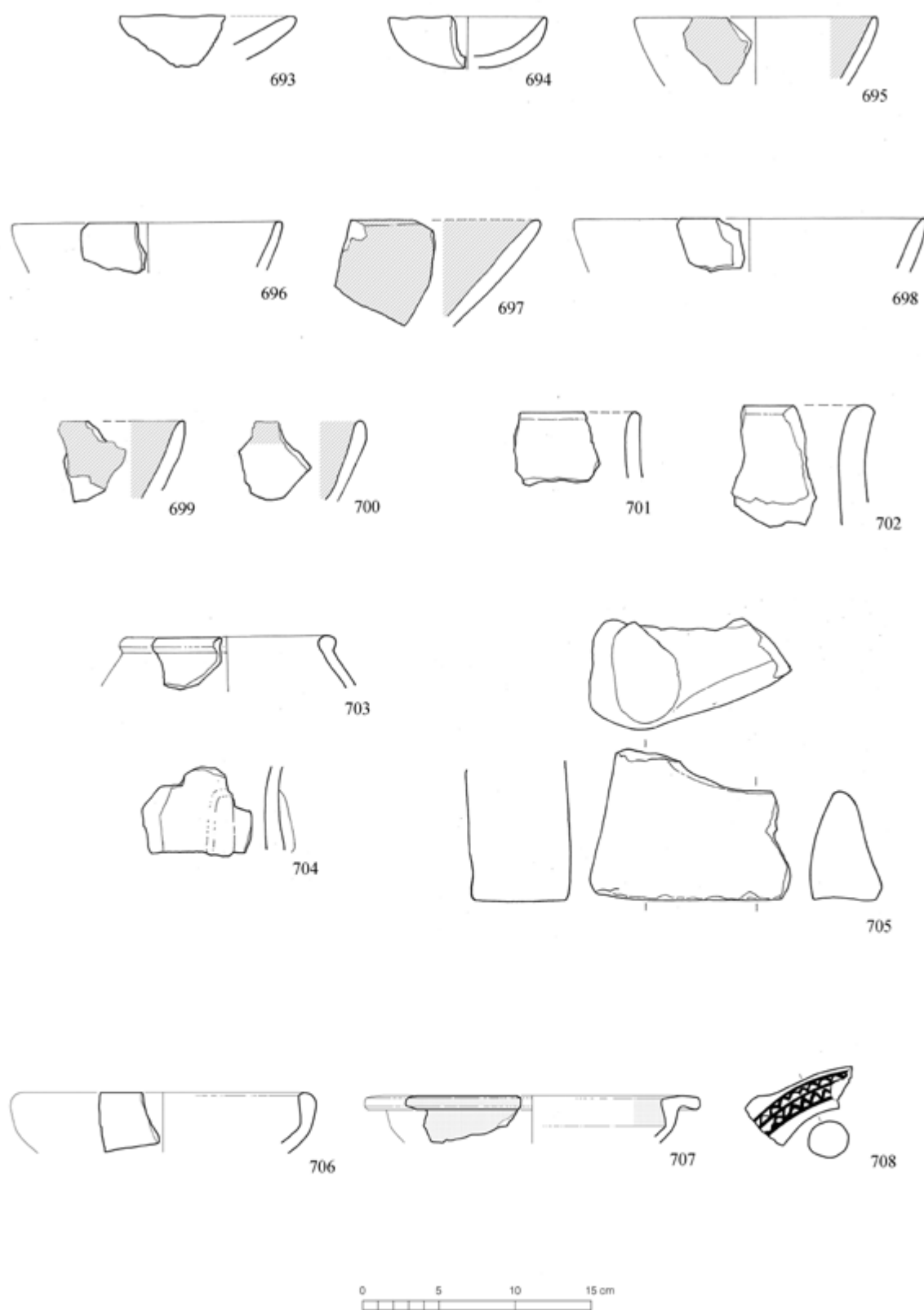


Fig. 37 – Pottery from Taşlık Höyük.

Figure 38a – SS-05

| n. | SS5n. | Type | W/Cl | E | ST | Fa | Colour (out.) | Colour (in.) | Colour (sect.) | T | Pl. |
|-----|-------|-------|------|---|----|----|-------------------|-------------------|-------------------|---|-----|
| 709 | 10.1 | 2A.16 | P/C | M | 2 | M | r.y. - 7.5 YR 7/6 | r.y. - 7.5 YR 7/6 | r.y. - 7.5 YR 7/6 | W | |
| 710 | 10.4 | Bsh | P/S | M | 4 | M | S: p.y. - 5 Y 7/4 | S: p.y. - 5 Y 7/4 | p.y. - 2.5 Y 7/4 | W | |

Figure 38b – SS-06

| n. | SS6n. | Type | W/Cl | E | ST | Fa | Colour (out.) | Colour (in.) | Colour (sect.) | T | Pl. |
|-----|-------|------|------|---|----|----|---------------------|---------------------|--|---|------|
| 711 | 10.2 | ZA.8 | P/C | M | 2S | M | l.r. - 2.5 YR 6/6 | l.r. - 2.5 YR 6/6 | l.r. - 2.5 YR 6/6 | W | 41.6 |
| 712 | 10.1 | ZA.8 | P/C | M | 2S | M | l.r. - 2.5 YR 6/6 | l.r. - 2.5 YR 6/6 | l.r. - 2.5 YR 6/6 | W | 41.6 |
| 713 | 10.4 | H10 | P/C | M | 4S | M | S: pi. - 7.5 YR 7/4 | S: pi. - 7.5 YR 7/4 | O: r.y. - 7.5 YR 7/6 C: l.g. - 5 YR 7/1 I: r.y. - 5 YR 7/6 | W | 41.6 |

Figure 38c – SS-07

| n. | SS7n. | Type | W/Cl | E | ST | Fa | Colour (out.) | Colour (in.) | Colour (sect.) | T | Pl. |
|-----|-------|------|------|---|----|----|-------------------|-------------------|--|---|------|
| 714 | 10.2 | 5 | P/C | M | 2 | M | l.r.br - 5 YR 6/4 | l.r.br - 5 YR 6/4 | O: l.r.br - 5 YR 6/4 C: l.g. - 5 YR 7/1 I: l.r.br - 5 YR 6/4 | W | 41.7 |
| 715 | 10.1 | ZA.9 | P/C | M | 2 | M | r.y. - 5 YR 6/6 | l.r. - 10 R 6/8 | O: r.y. - 5 YR 6/6 I: l.r. - 10 R 6/8 | W | 41.7 |
| 716 | 10.4 | ZA.9 | P/S | M | 2 | M | l.r. - 2.5 YR 6/6 | l.r. - 2.5 YR 6/6 | O: l.r. - 2.5 YR 6/6 C: r.g. - 2.5 YR 6/1 I: l.r. - 2.5 YR 6/6 | W | 41.7 |
| 717 | 10.38 | B7 | P/C | M | 2 | M | y.br. - 10 YR 5/4 | y.br. - 10 YR 5/4 | y.br. - 10 YR 5/4 | W | |

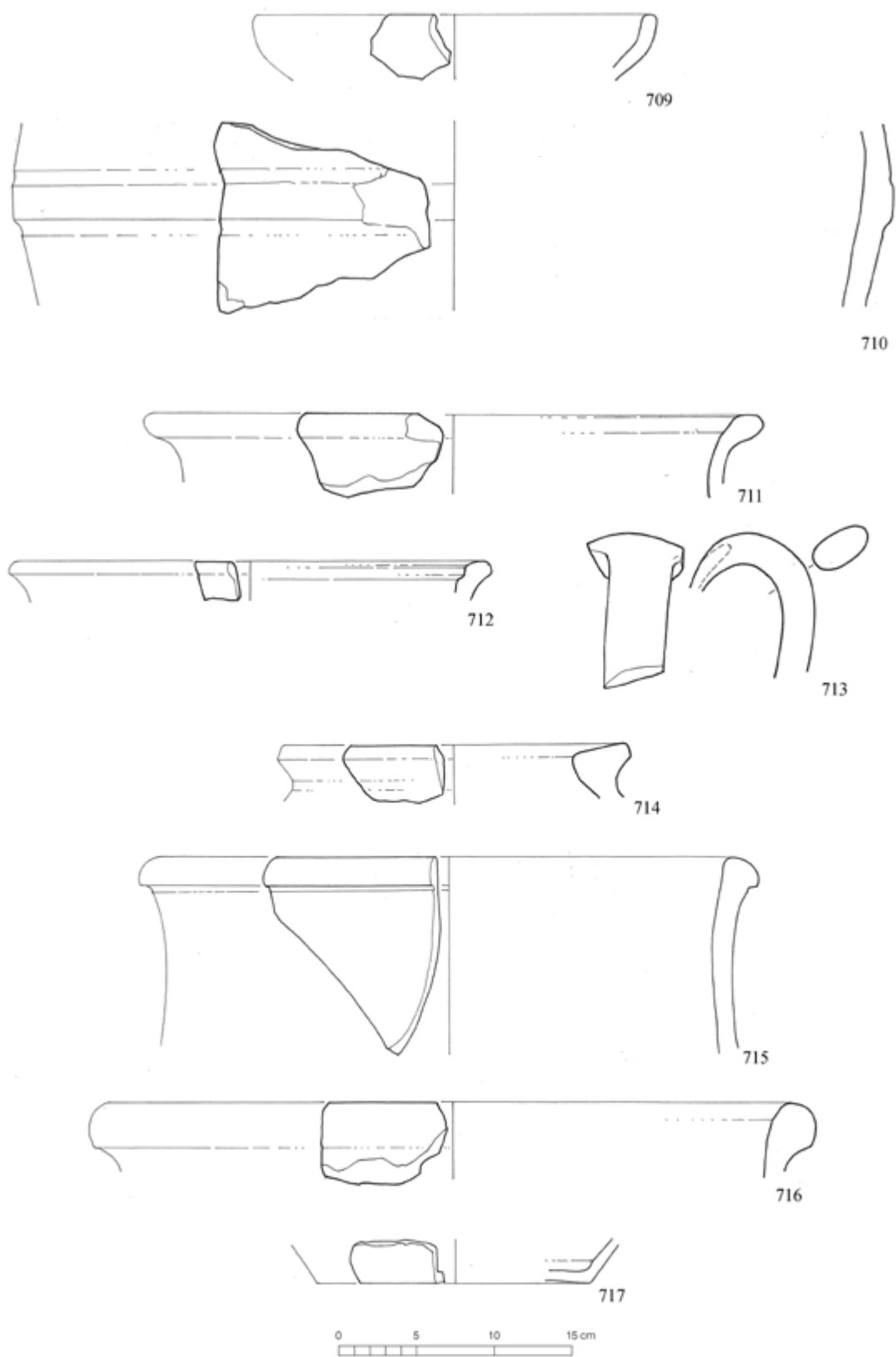


Fig. 38 – Pottery from sites nos 5, 6 and 7.

Figure 39 – SS-09 Aşağı Karakaya Köyü

| n. | SS9n. | Type | W/Cl | E | ST | Fa | Colour (out.) | Colour (in.) | Colour (sect.) | T | Pl. |
|-----|--------|----------|------------|----|-----|----|---|---|---|---|--------------|
| 718 | 10.4 | 2 | Bb/F | F | 2Bo | M | y.r. - 5 YR 5/6 | y.r. - 5 YR 5/6 | y.r. - 5 YR 5/6 | W | 40.7 |
| 719 | 10.1 | 2A.20e | White slip | MF | 4 | M | S: pi.w. - 5 YR 8/2 | S: pi.w. - 5 YR 8/2 | l.r. - 2.5 YR 6/6 | W | 40.6 |
| 720 | 10.5 | 2B.6 | P/C | M | 2 | M | r.br. - 2.5 YR 5/4 | r.br. - 2.5 YR 5/4 | r.br. - 2.5 YR 5/4 | W | |
| 721 | 10.2 | 2A.28 | Rs/C | M | 4Bo | M | S: l.r.br. - 2.5 YR 6/4, pi. - 5 YR 7/4 | S: l.r.br. - 2.5 YR 6/4, pi. - 5 YR 7/4 | O: r.y. - 5 YR 6/6 C: l.br. - 7.5 YR 6/3 I: v.p.br. - 10 YR 8/2 | W | |
| 722 | 10.16 | 6C.5 | Br/C | M | 2 | M | l.r.br. - 2.5 YR 6/4 | we.r. - 10 R 5/4 | O: l.r.br. - 2.5 YR 6/4 C: l.r. - 10 R 6/6 I: we.r. - 10 R 5/4 | W | |
| 723 | 10.17 | 6C.5 | P/C | M | 2S | M | r.br. - 5 YR 5/4 | r.br. - 5 YR 5/4 | O: r.br. - 5 YR 5/4 C: y.r. - 5 YR 5/6 I: r.br. - 5 YR 5/4 | W | 40.1 40.3 |
| 724 | 10.11 | 6C.5 | Br/C | M | 2 | M | we.r. - 10 R 5/4, r. - 10 R 5/8 | we.r. - 10 R 5/4, r. - 10 R 5/8 | O: r. - 10 R 5/8 C: d.r.g. - 10 R 4/1 I: r. - 10 R 5/8 | W | 40.1 |
| 725 | 10.8 | 6C.5 | Br/C | M | 2 | M | r.br. - 2.5 YR 5/4, we.r. - 2.5 YR 4/2 | r.br. - 2.5 YR 5/4, we.r. - 2.5 YR 4/2 | we.r. - 2.5 YR 4/2 | W | 40.1 |
| 726 | 10.14 | 6C.5 | Br/C | M | 2 | M | g. - 7.5 YR 5/1, br. - 7.5 YR 5/2 | br. - 7.5 YR 5/2, l.r.br. - 5 YR 6/4 | O: br. - 7.5 YR 5/2 C: d.g. - 5 YR 4/1 I: br. - 7.5 YR 5/2 | W | |
| 727 | 10.12 | 6C.5 | Br/C | M | 2 | M | r.br. - 2.5 YR 5/4 | r.br. - 2.5 YR 5/4 | O: r.br. - 2.5 YR 5/4 C: r.g. - 2.5 YR 5/1 I: r.br. - 2.5 YR 5/4 | W | 40.1 |
| 728 | 10.10 | 6C.5 | P/C | M | 2 | M | r.br. - 5 YR 5/4 | y.r. - 5 YR 5/6 | O: r.br. - 5 YR 5/4 I: y.r. - 5 YR 5/6 | W | 40.1 |
| 729 | 10.15 | 6C.8 | P/C | M | 2Bo | M | r.br. - 5 YR 4/3 | br. - 7.5 YR 5/3 | O: r.br. - 5 YR 4/3 I: br. - 7.5 YR 5/3 | W | 40.1 40.3 |
| 730 | 10.7 | 6C.5 | Br/C | M | 2S | M | d.r.g. - 10 R 3/1, r. - 2.5 YR 5/6 | r. - 2.5 YR 5/6, l.r. - 2.5 YR 6/8 | O: r. - 2.5 YR 5/6 C: r.g. - 2.5 YR 5/1 I: r. - 2.5 YR 5/6 | W | 40.1 |
| 731 | 10.6+9 | 6C.5 | Br/C | M | 2S | M | r. - 2.5 YR 5/6, r. - 2.5 YR 4/8 | r. - 2.5 YR 5/6, r. - 2.5 YR 4/8 | O: r. - 2.5 YR 4/8 C: y.r. - 5 YR 5/6 I: r. - 2.5 YR 4/8 | W | 40.1 |
| 732 | 10.21 | 6C5, H10 | P/C | M | 2 | M | r.br. - 5 YR 5/4 | r.br. - 5 YR 5/4 | O: r.br. - 5 YR 5/4 C: r. - 2.5 YR 5/6 I: r.br. - 5 YR 5/4 | W | |
| 733 | 10.33 | H12 | Br/K | M | 2 | M | r.br. - 5 YR 5/4, r.br. - 5 YR 4/4 | r.br. - 5 YR 5/4, r.br. - 5 YR 4/4 | O: r.br. - 5 YR 4/4 C: gr.g. - GLEY 1 10 Y 5/1, d.g. - GLEY 1 N 4 I: r.br. - 5 YR 4/4 | W | 40.4 |
| 734 | 10.27 | H3 | P/C | M | 2 | M | l.r.br. - 2.5 YR 6/4 | l.r. - 2.5 YR 6/6 | O: l.r.br. - 2.5 YR 6/4 I: l.r. - 2.5 YR 6/6 | W | 40.9 |
| 735 | 10.18 | H12 | Br/K | M | 2 | M | r.br. - 2.5 YR 4/4 | r.br. - 2.5 YR 4/4 | O: r.br. - 2.5 YR 4/4 C: gr.g. - GLEY 1 10 Y 5/1, d.g. - GLEY 1 N 4 I: r.br. - 2.5 YR 4/4 | W | 40.4 |
| 736 | 10.32 | H12 | Br/K | M | 2 | M | r. - 2.5 YR 4/6 | r. - 2.5 YR 4/6 | O: r. - 2.5 YR 4/6 C: l.g. - 2.5 Y 7/1 I: r. - 2.5 YR 4/6 | W | 40.4 |

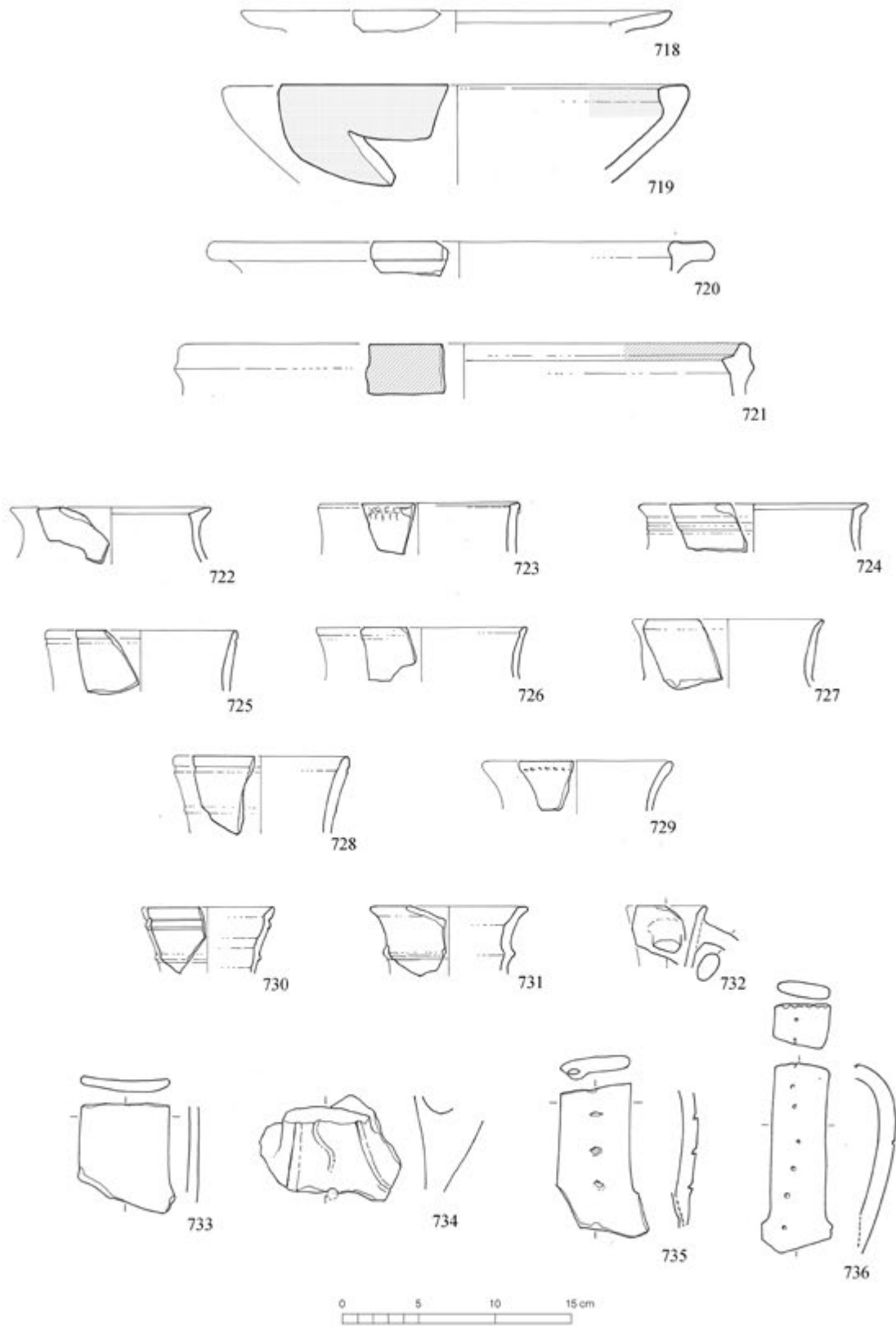


Fig. 39 – Pottery from Aşağı Karakaya Höyük.

Figure 40 – SS-09 Aşağı Karakaya Köy

| n. | SS9n. | Type | W/Cl | E | ST | Fa | Colour (out.) | Colour (in.) | Colour (sect.) | T | Pl. |
|-----|-------|------|------|---|----|----|----------------------|----------------------|--|---|-------|
| 737 | 10.50 | Bsh | P/C | M | 3S | M | Ss: pi. - 7.5 YR 7/3 | l.r. - 2.5 YR 6/6 | l.r. - 2.5 YR 6/6 | W | 40.11 |
| 738 | 10.47 | Bsh | Br/C | M | 2S | M | r.br. - 5 YR 5/3 | r. - 2.5 YR 5/6 | O: r.br. - 2.5 YR 4/4 C: r.g. - 2.5 YR 5/1 I: r. - 2.5 YR 5/6 | W | 40.2 |
| 739 | 10.49 | Bsh | P/C | M | 2 | M | l.br. - 7.5 YR 6/4 | l.br. - 7.5 YR 6/4 | O: l.br. - 7.5 YR 6/4 C: g. - 5 YR 5/1 I: l.br. - 7.5 YR 6/4 | W | 40.5 |
| 740 | 10.35 | B1 | Br/C | M | 2B | M | r.br. - 5 YR 5/4 | y.r. - 5 YR 5/6 | O: r.br. - 5 YR 5/4 I: y.r. - 5 YR 5/6 | W | |
| 741 | 10.40 | B1 | P/C | M | 2 | M | l.r.br. - 2.5 YR 6/3 | l.r.br. - 2.5 YR 6/4 | O: l.r.br. - 2.5 YR 6/4 C: r. - 2.5 YR 5/6 I: l.r.br. - 2.5 YR 6/4 | W | |

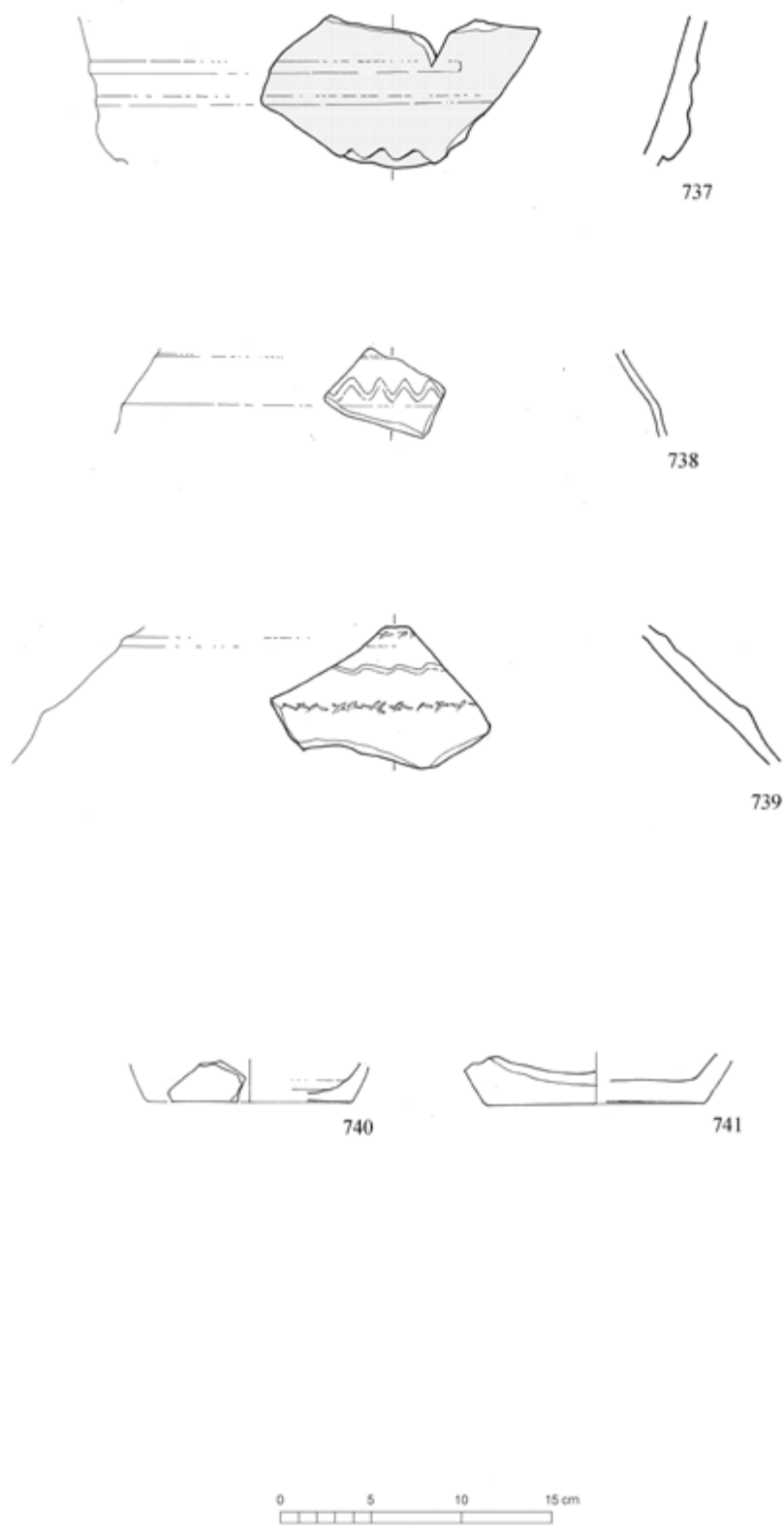


Fig. 40 – Pottery from Aşağı Karakaya Höyük.

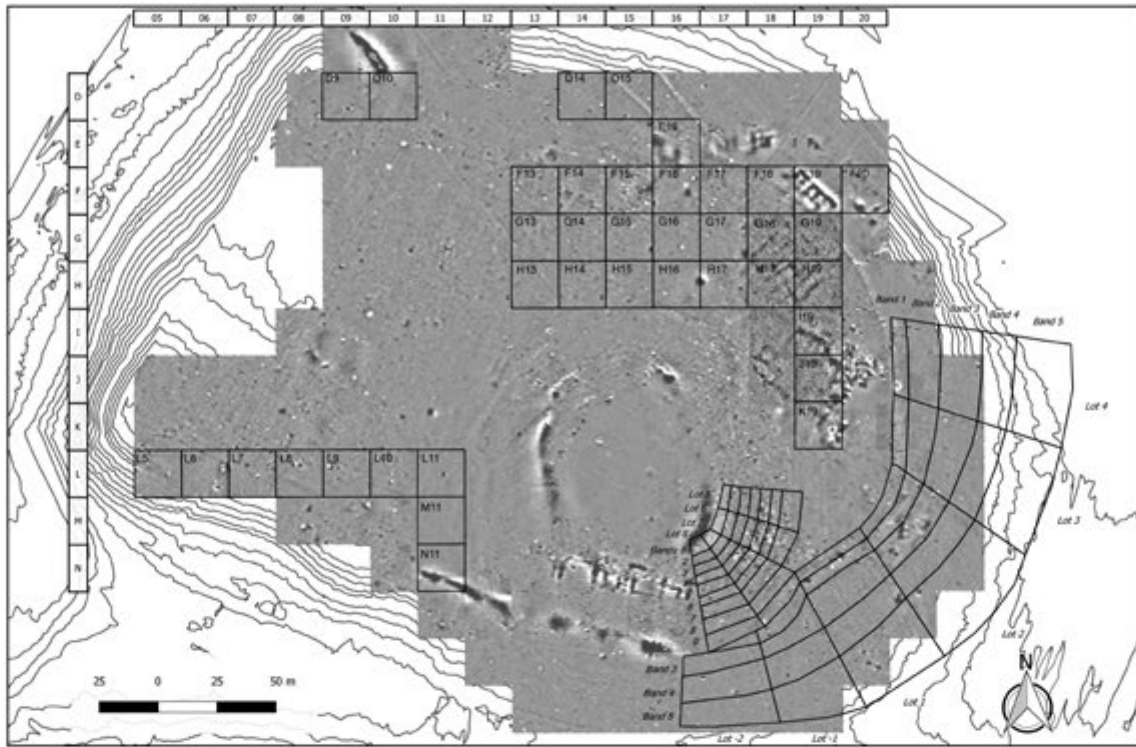


Fig. 41 –Uşaklı Höyük, sampling survey units.

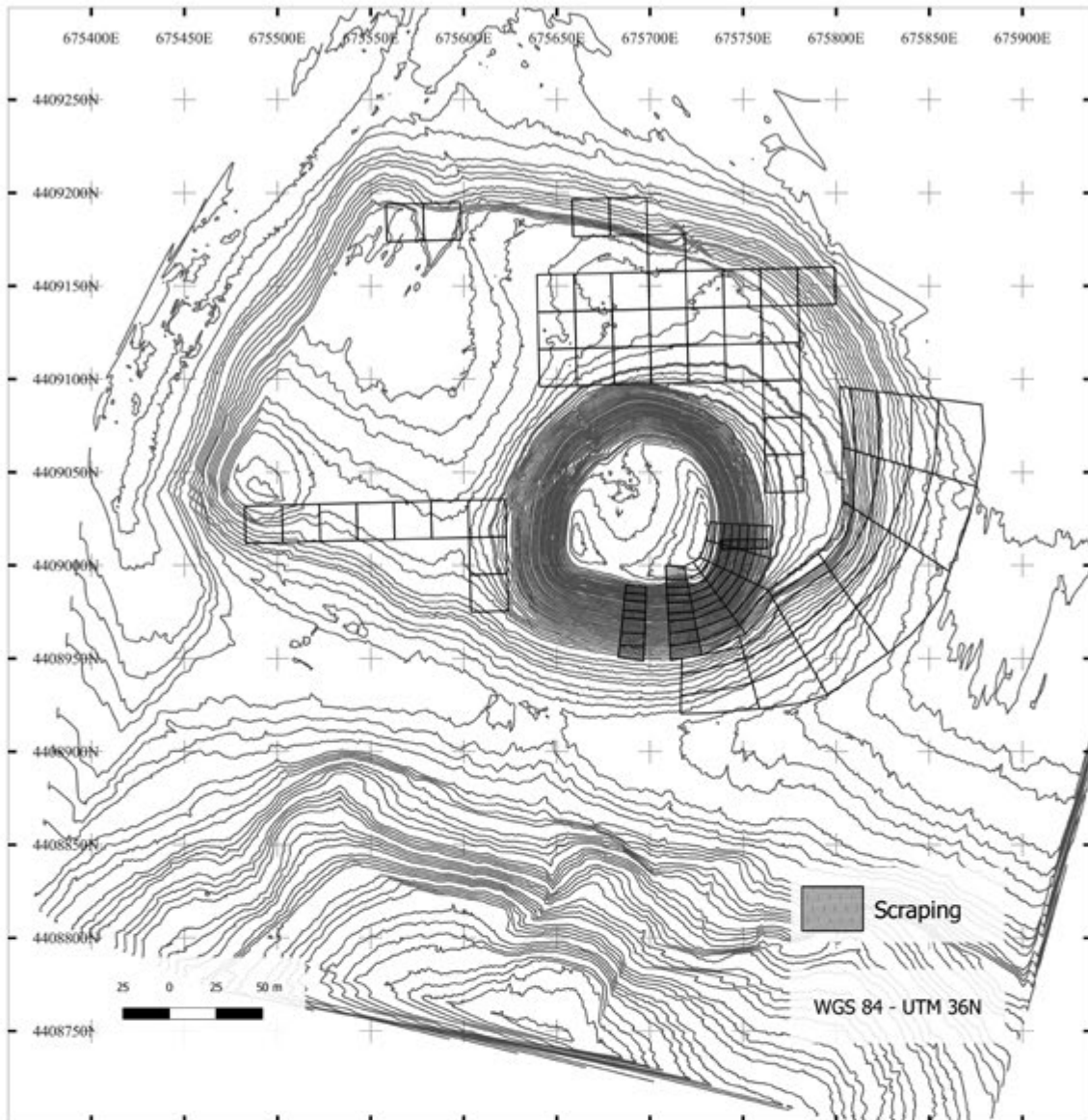


Fig. 42 –Uşaklı Höyük, survey and scraping units.

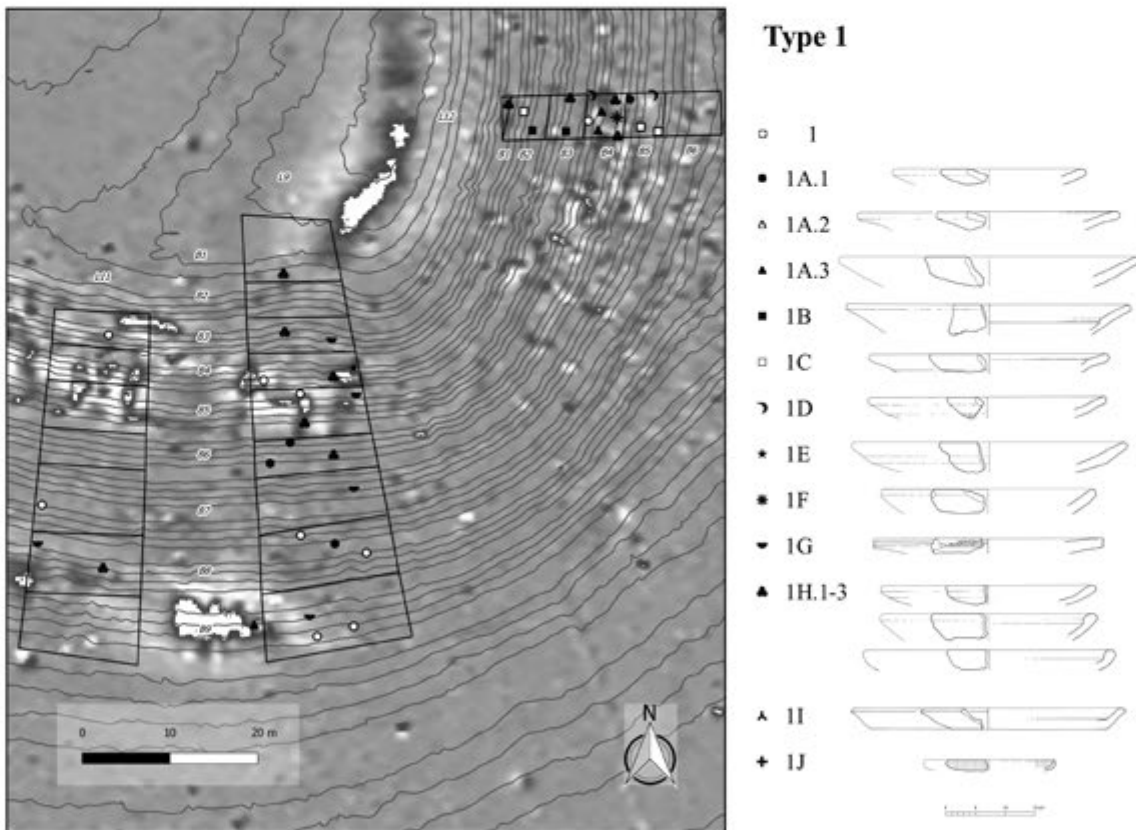
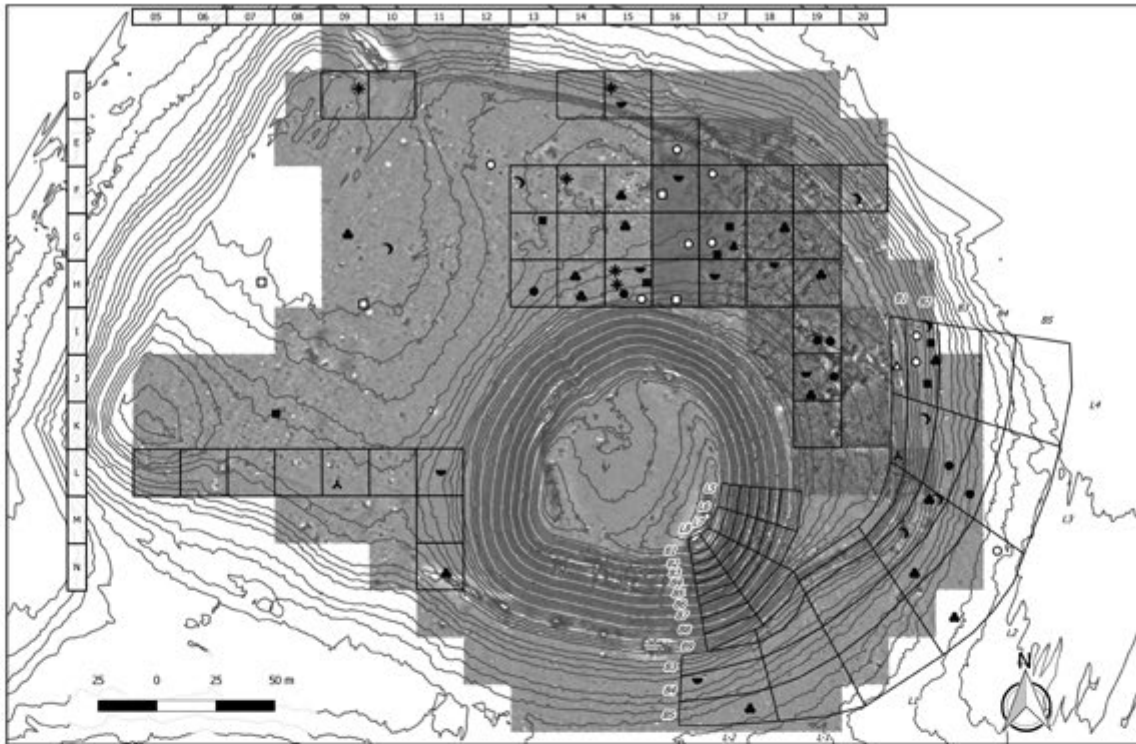


Fig. 43 – Uşaklı Höyük, scatter of ceramic artifacts (diagnostic types).

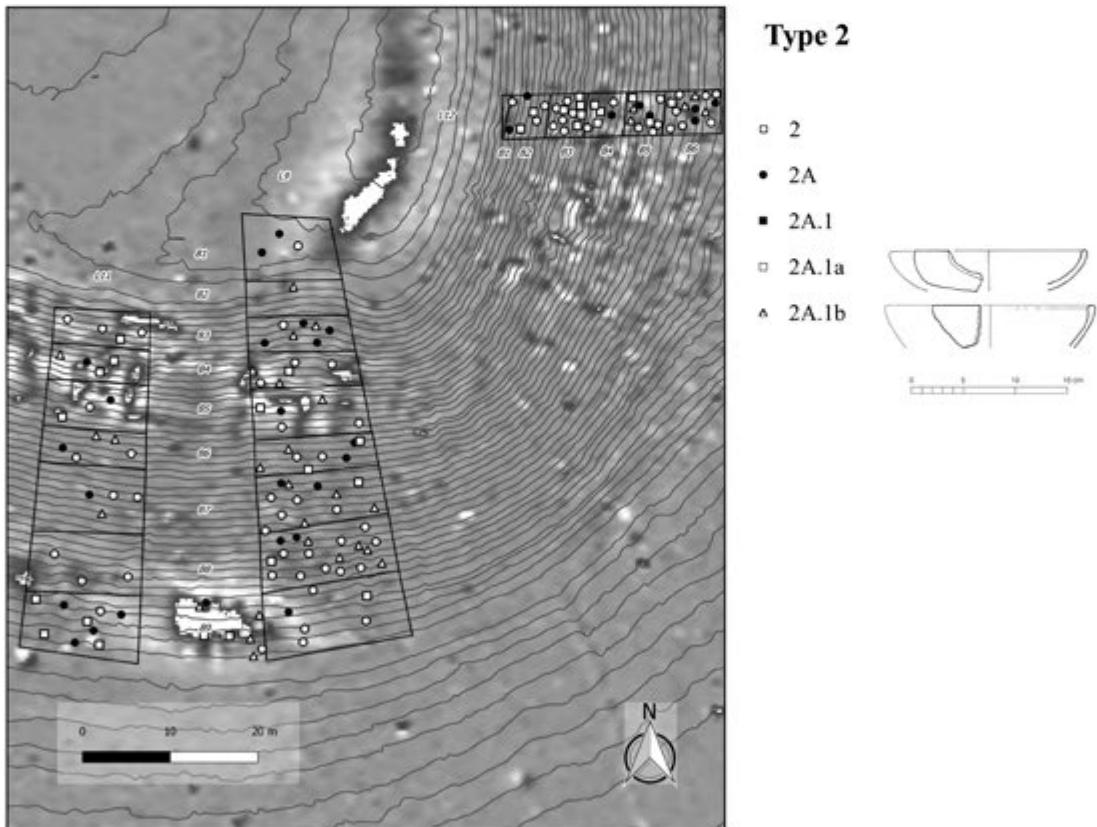
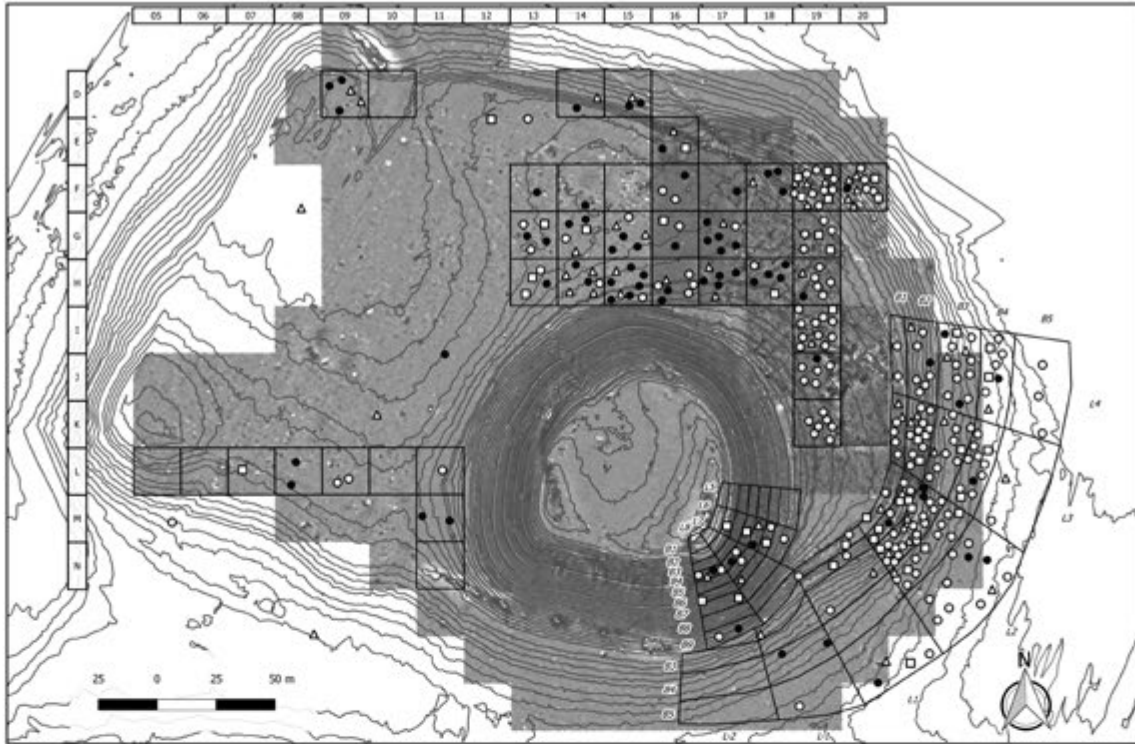


Fig. 44 – Uşaklı Höyük, scatter of ceramic artifacts (diagnostic types).

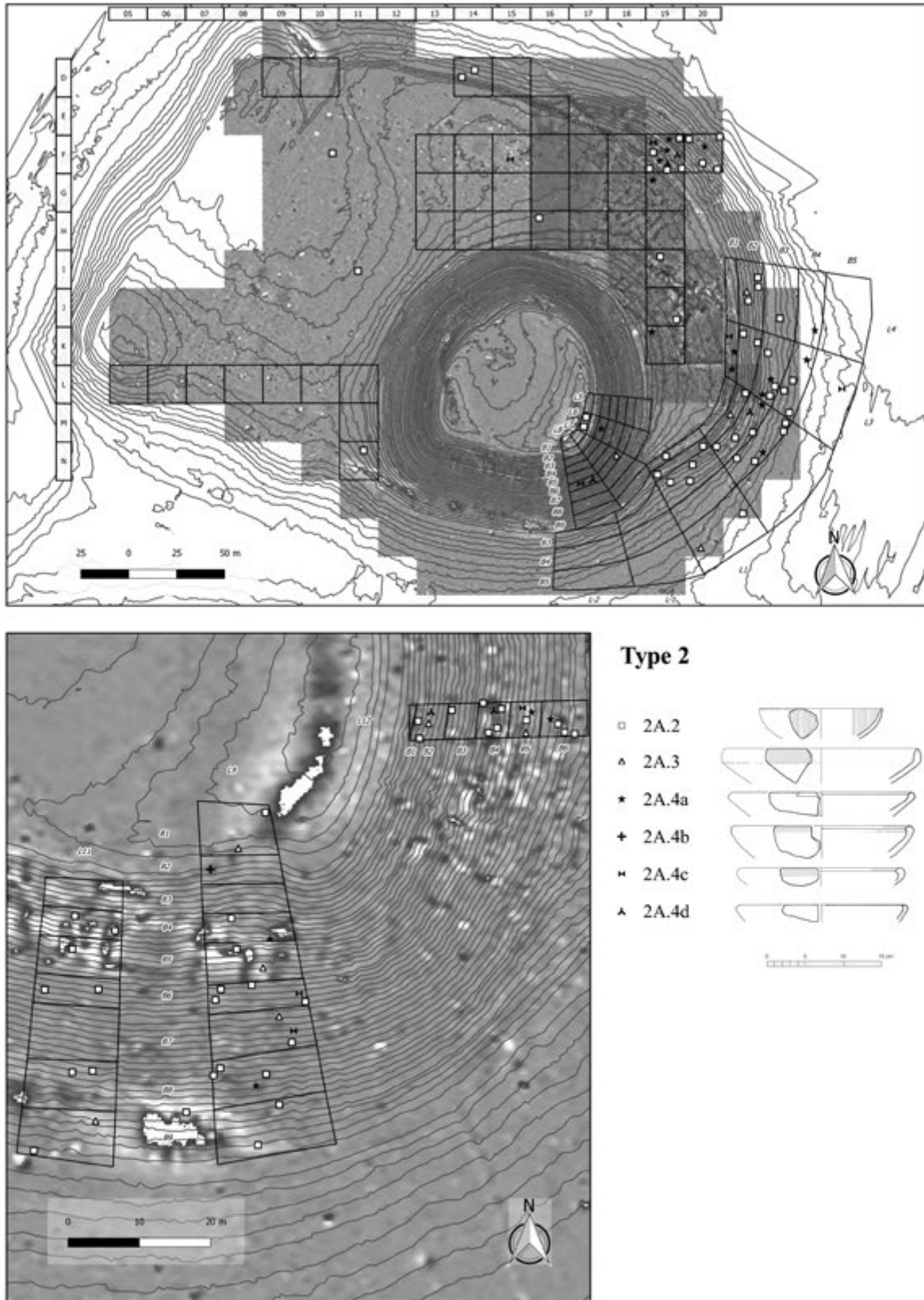


Fig. 45 – Uşaklı Höyük, scatter of ceramic artifacts (diagnostic types).

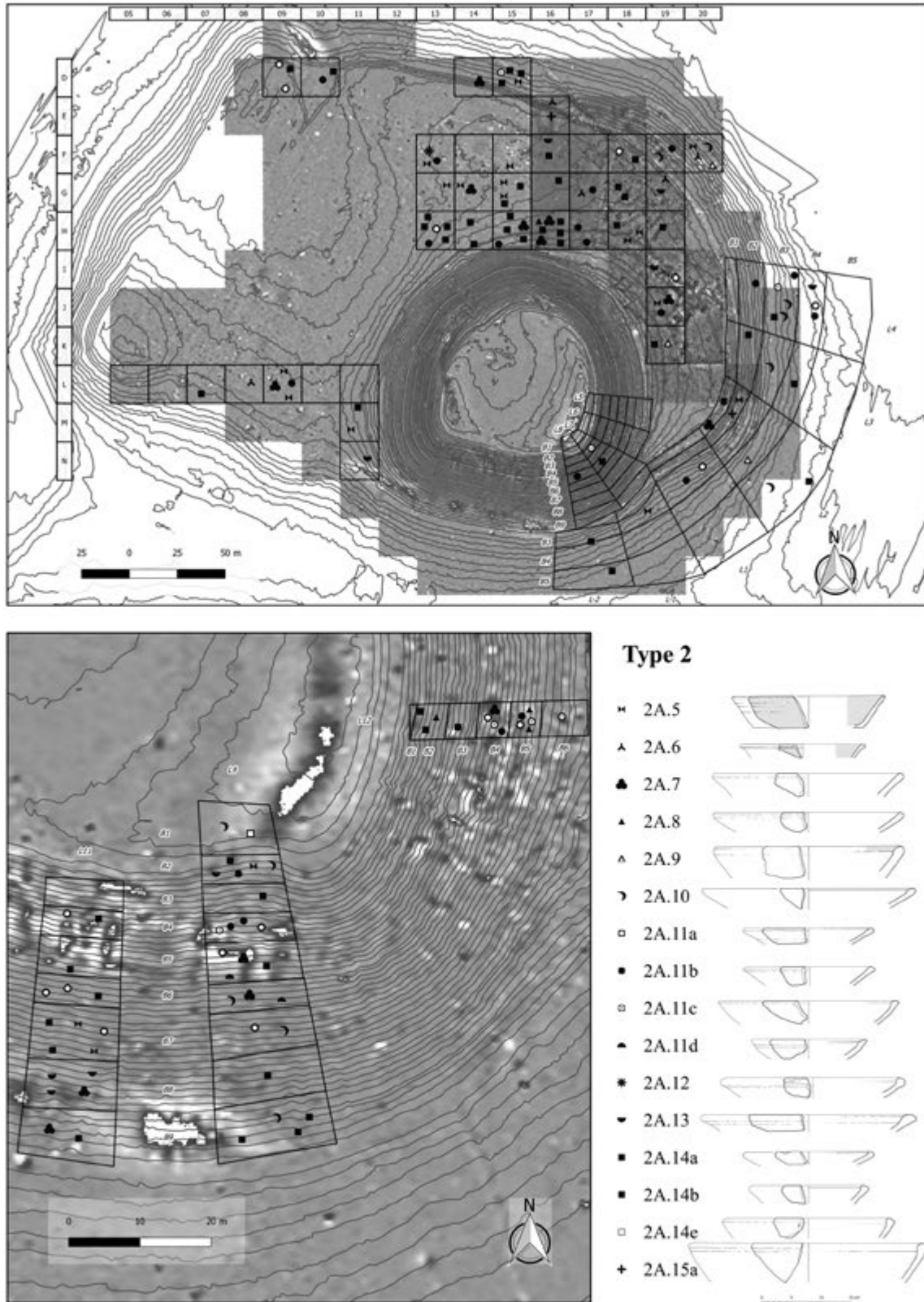


Fig. 46 – Uşaklı Höyük, scatter of ceramic artifacts (diagnostic types).

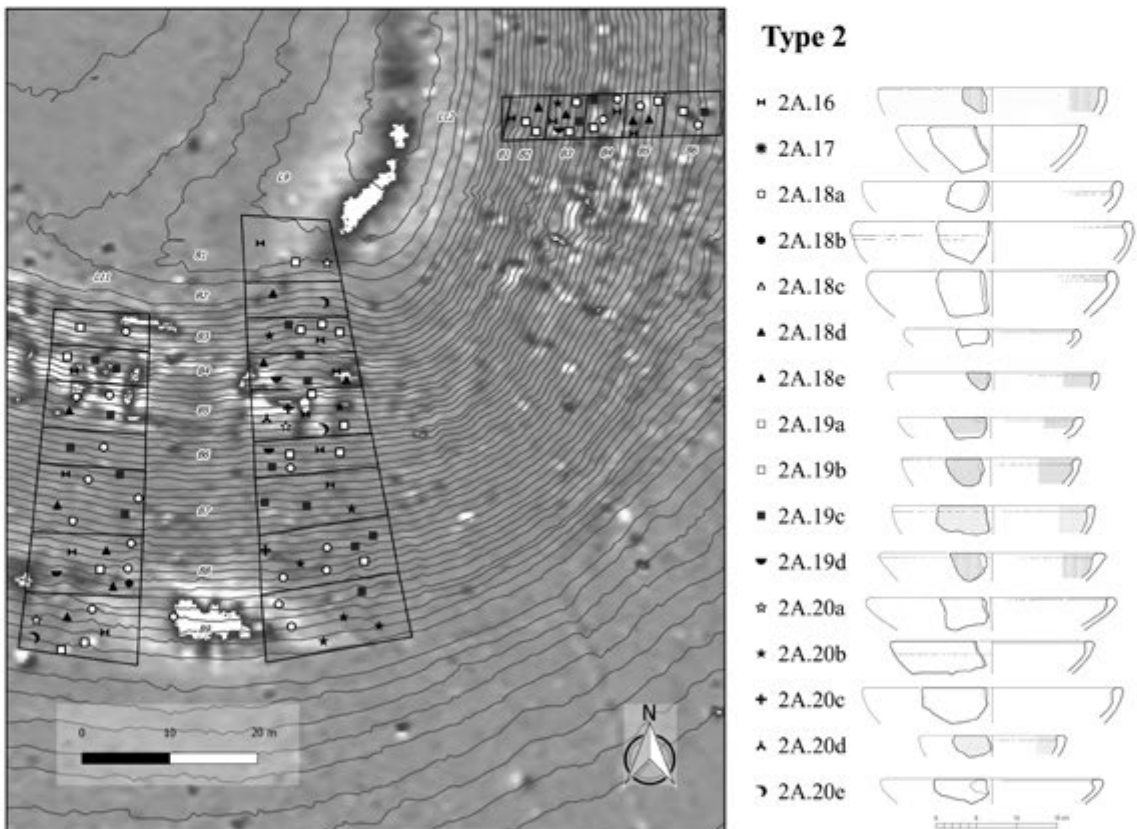
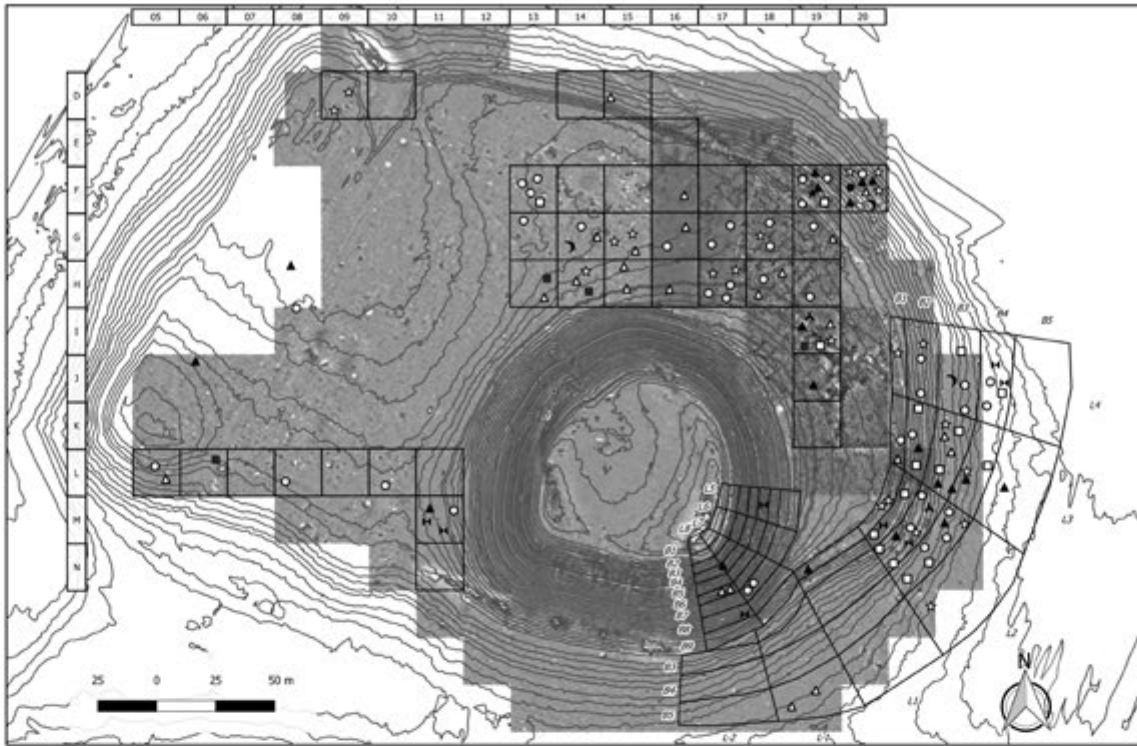


Fig. 47 – Uşaklı Höyük, scatter of ceramic artifacts (diagnostic types).

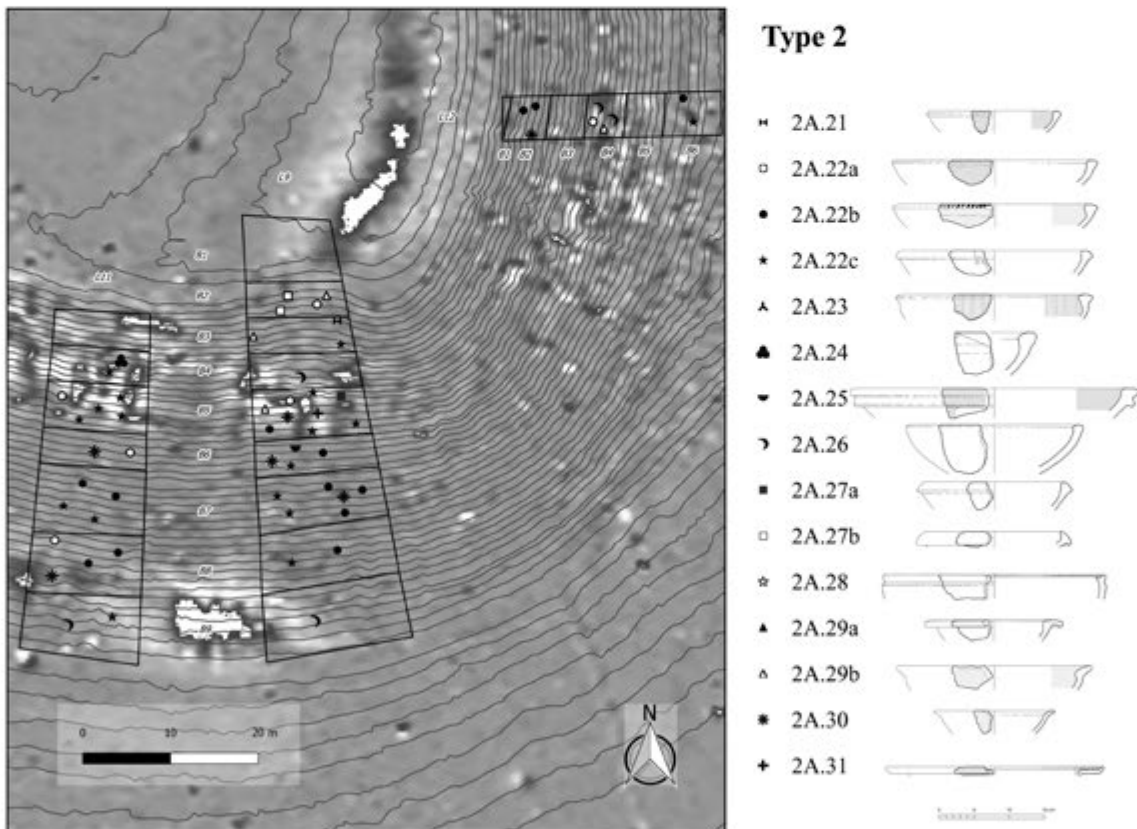
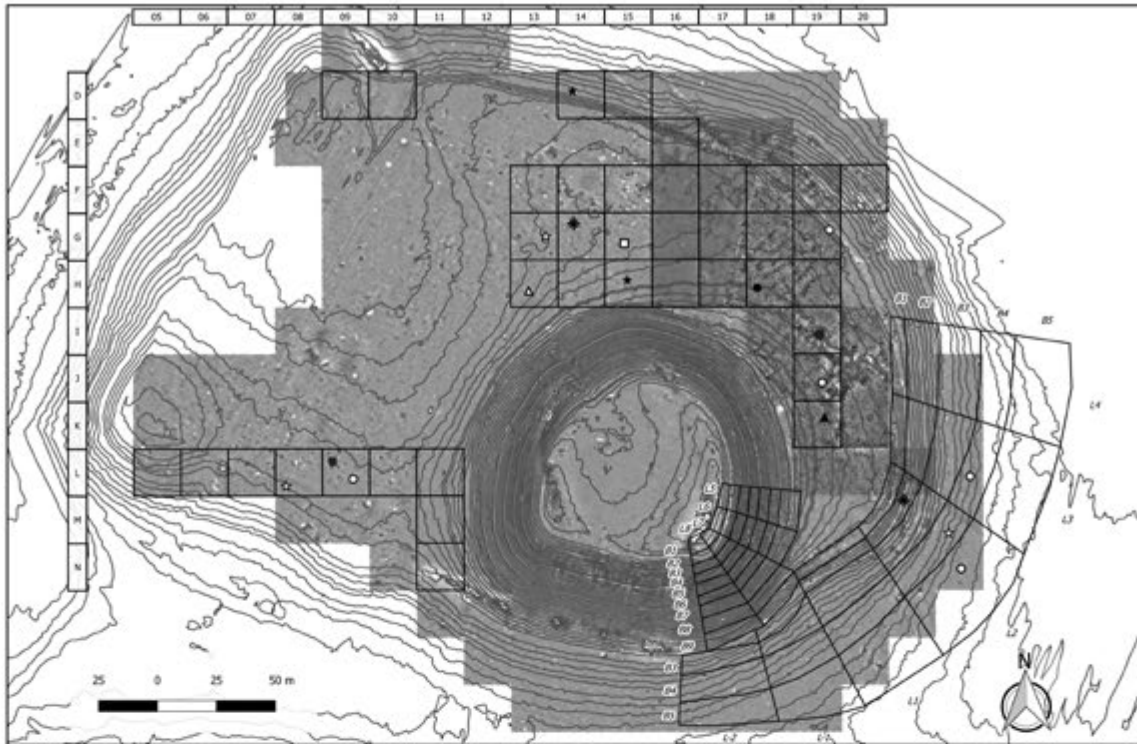


Fig. 48 – Uşaklı Höyük, scatter of ceramic artifacts (diagnostic types).

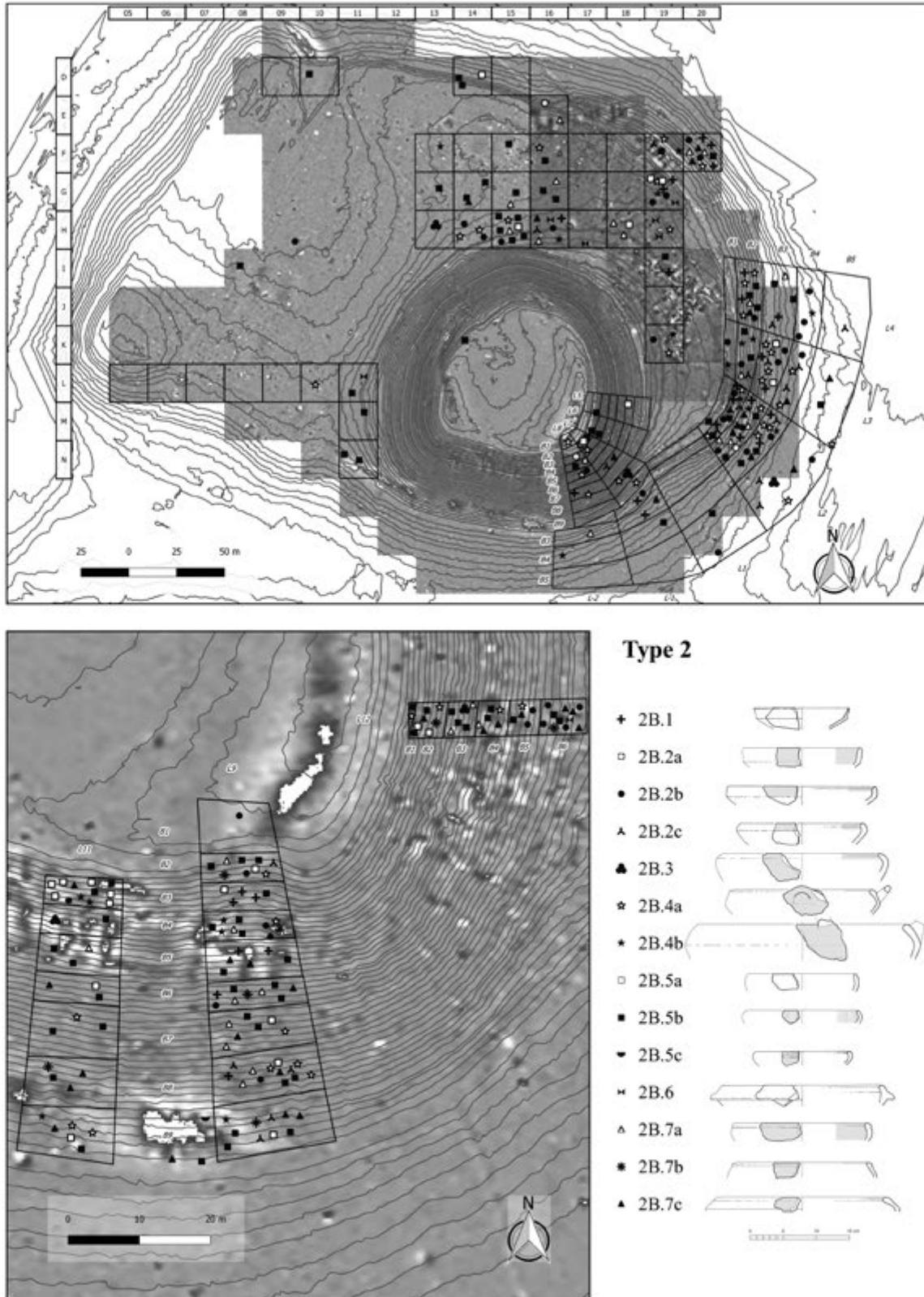


Fig. 49 – Uşaklı Höyük, scatter of ceramic artifacts (diagnostic types).

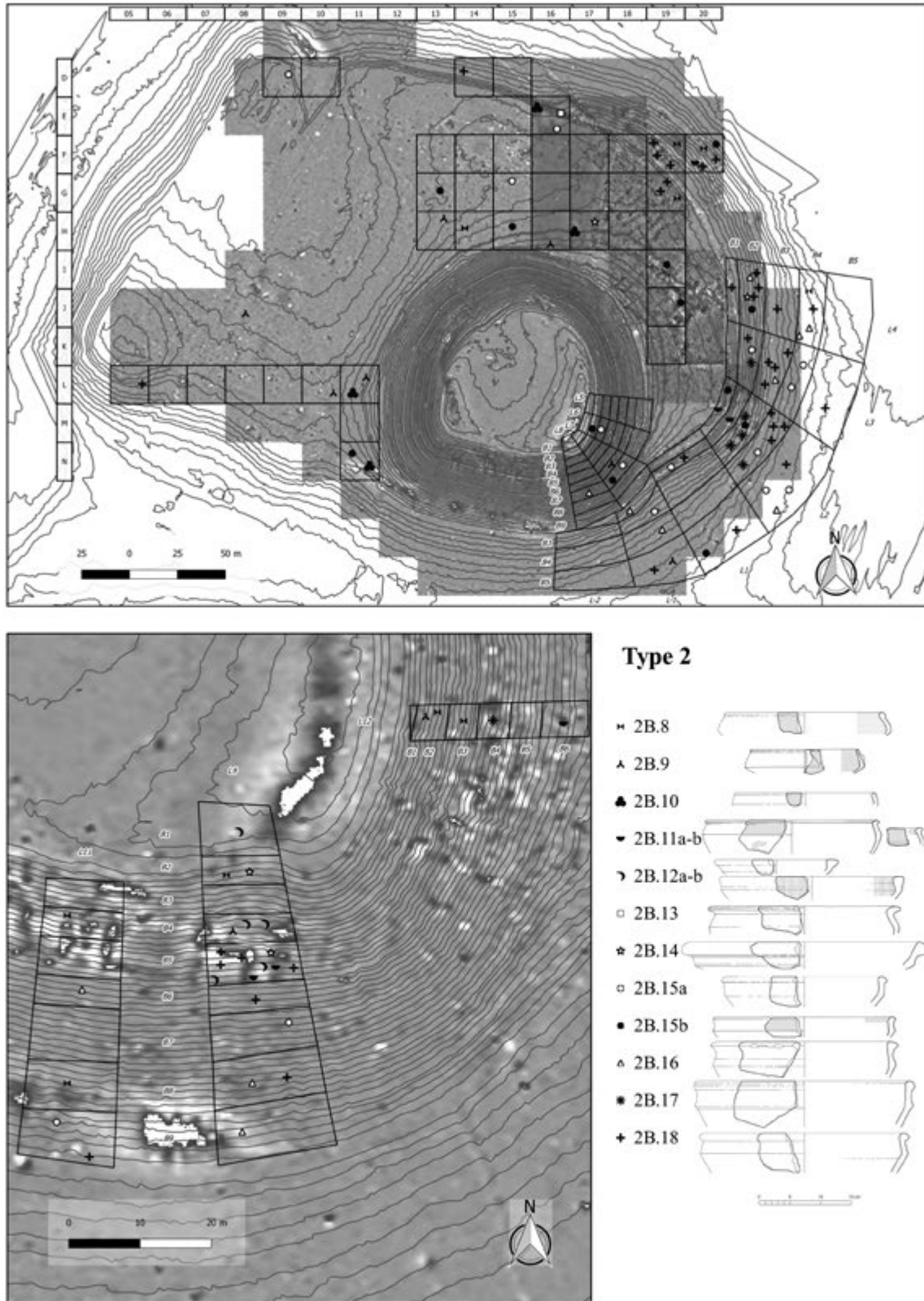


Fig. 50 – Uşaklı Höyük, scatter of ceramic artifacts (diagnostic types).

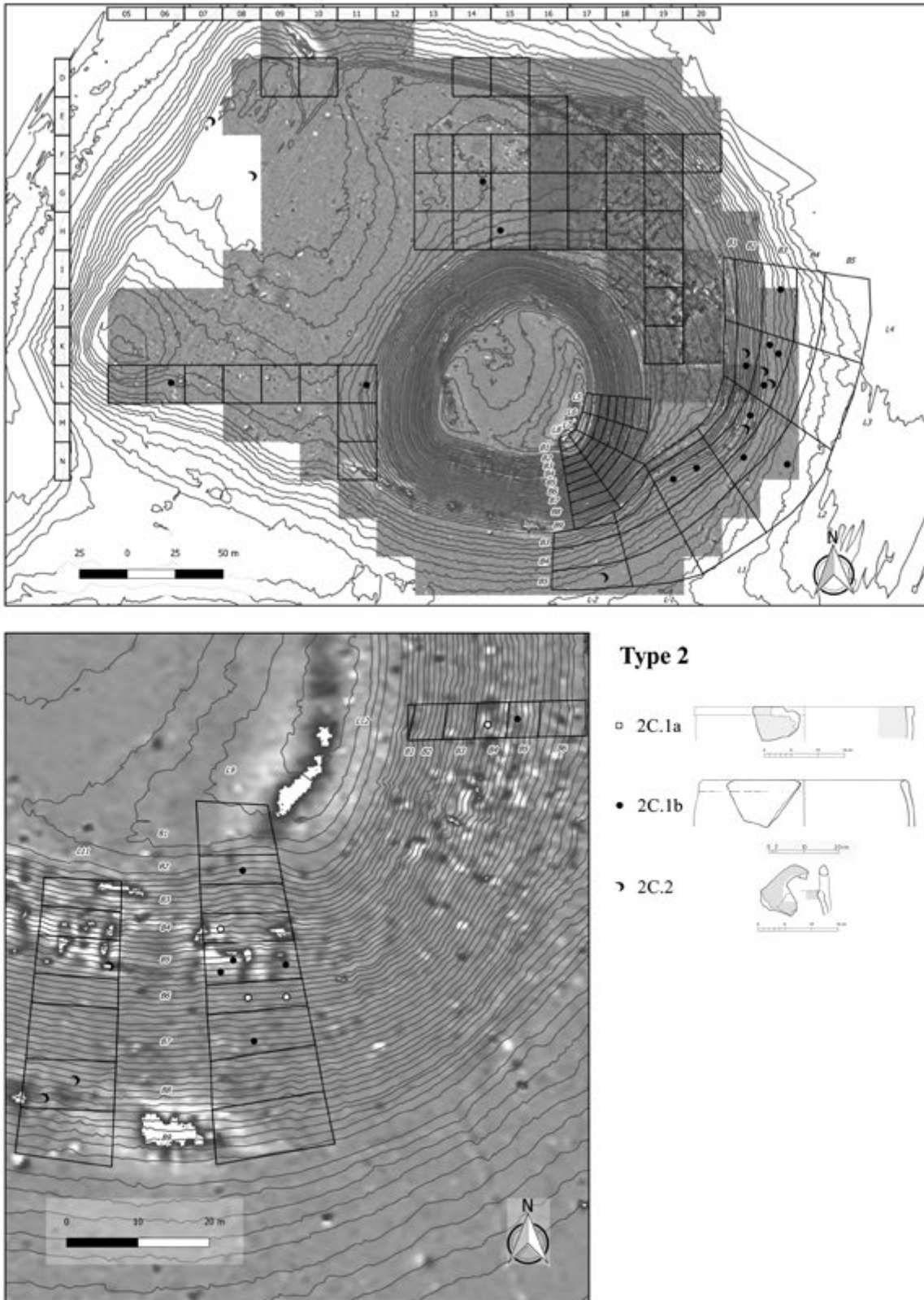


Fig. 51 – Uşaklı Höyük, scatter of ceramic artifacts (diagnostic types).

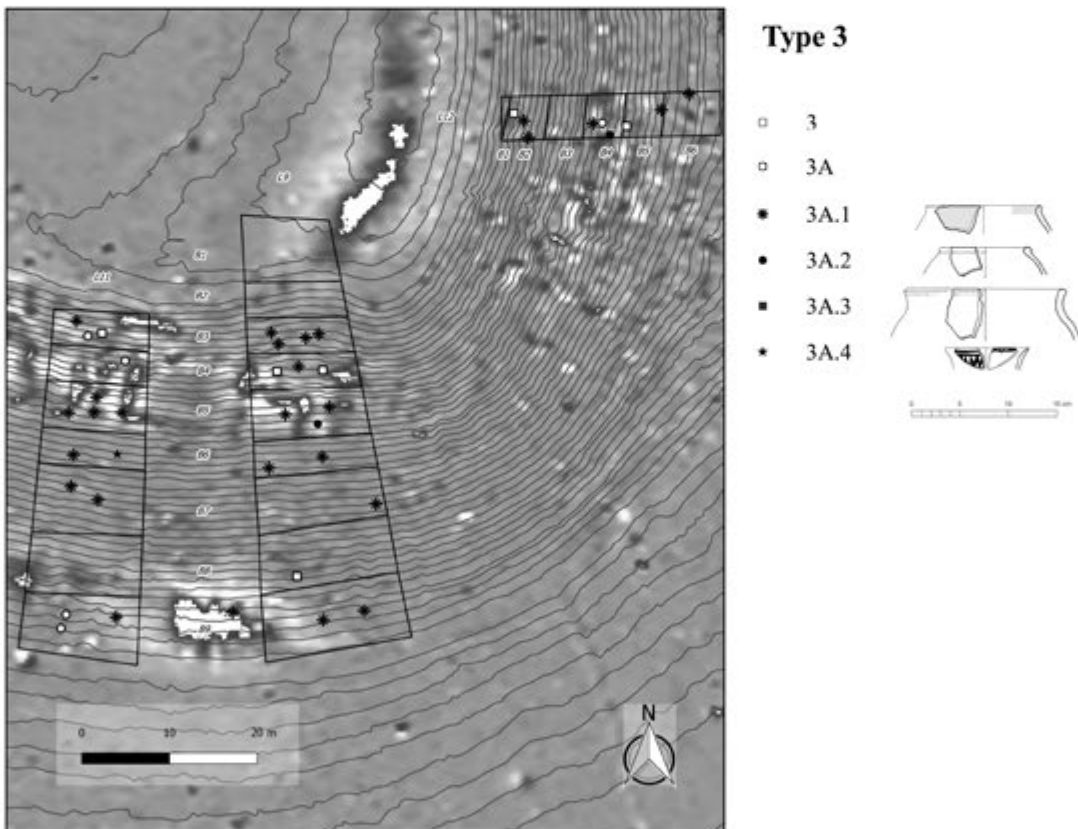
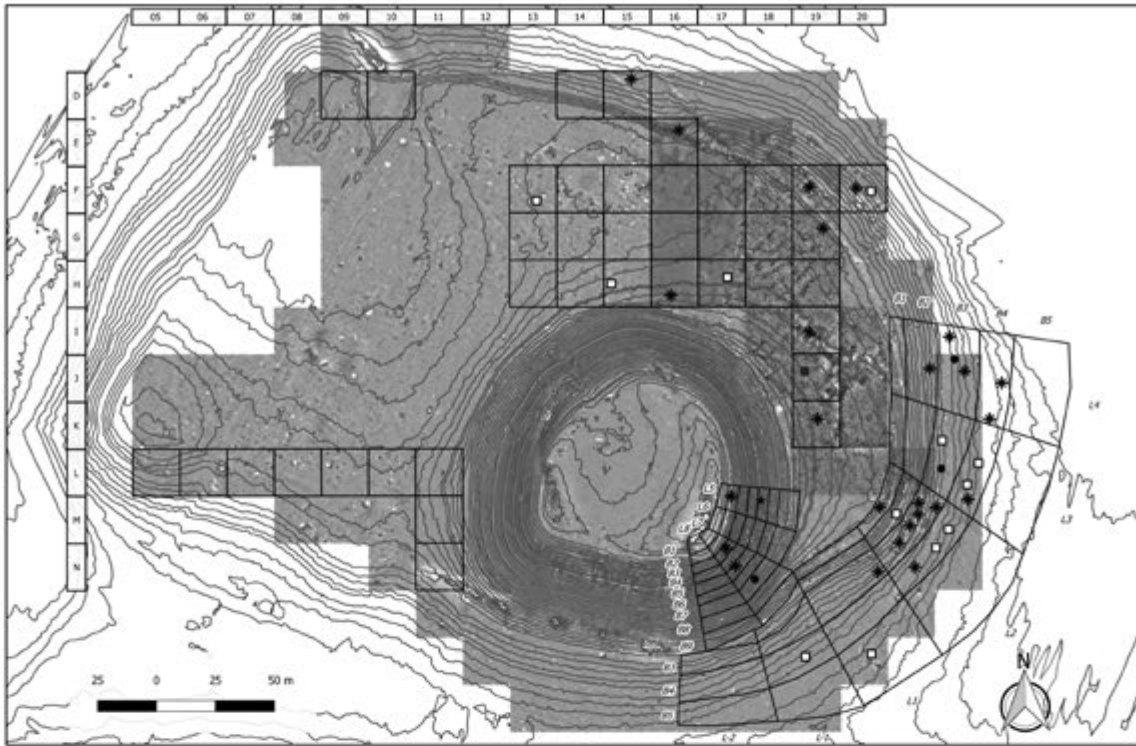


Fig. 52 – Uşaklı Höyük, scatter of ceramic artifacts (diagnostic types).

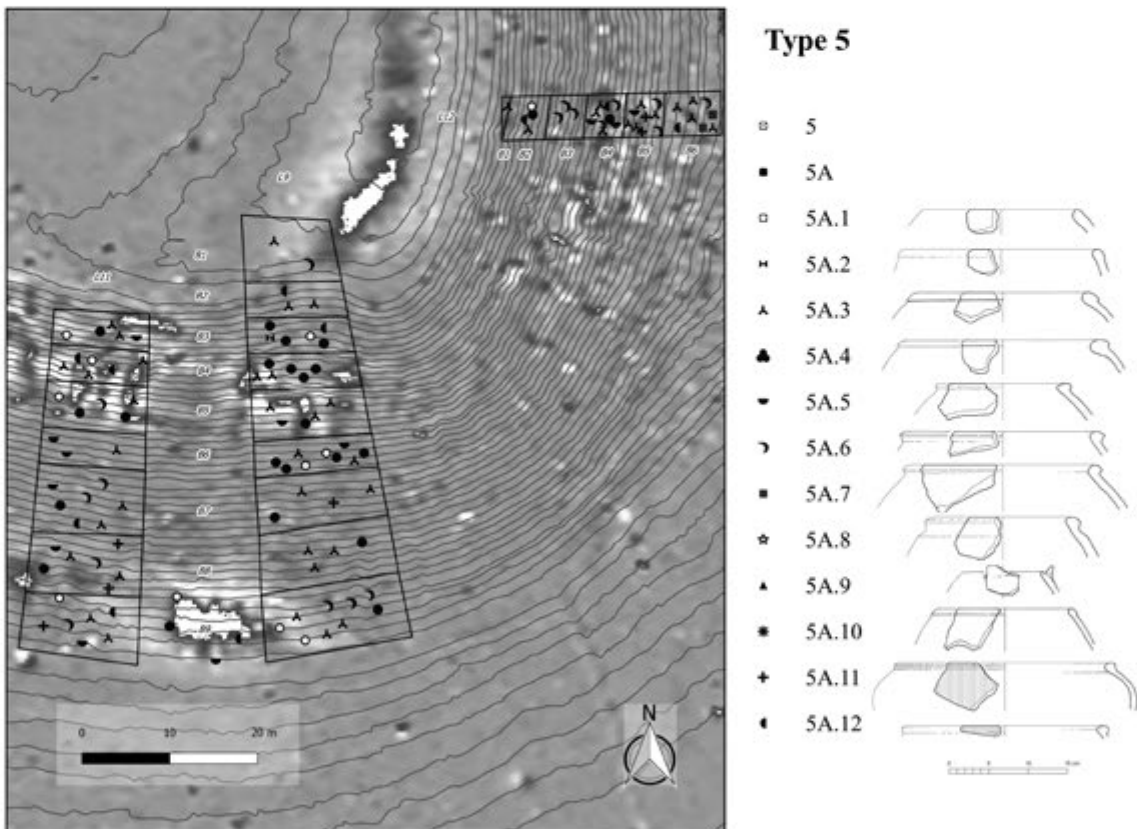
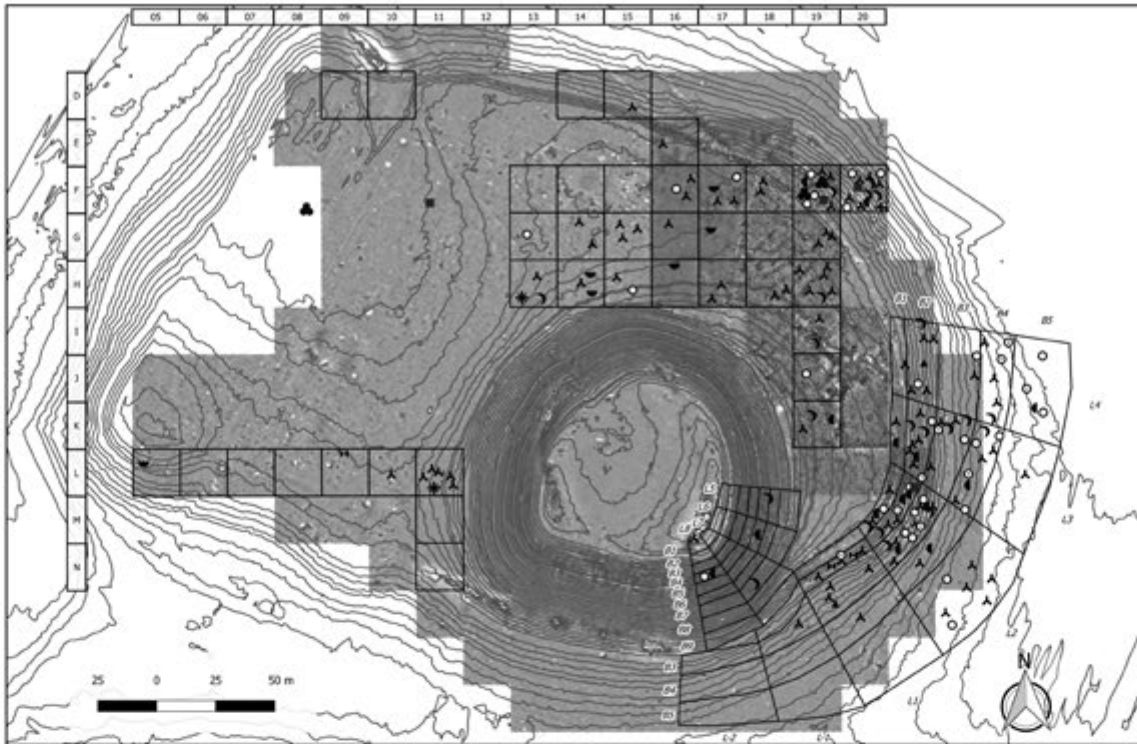


Fig. 53 – Uşaklı Höyük, scatter of ceramic artifacts (diagnostic types).

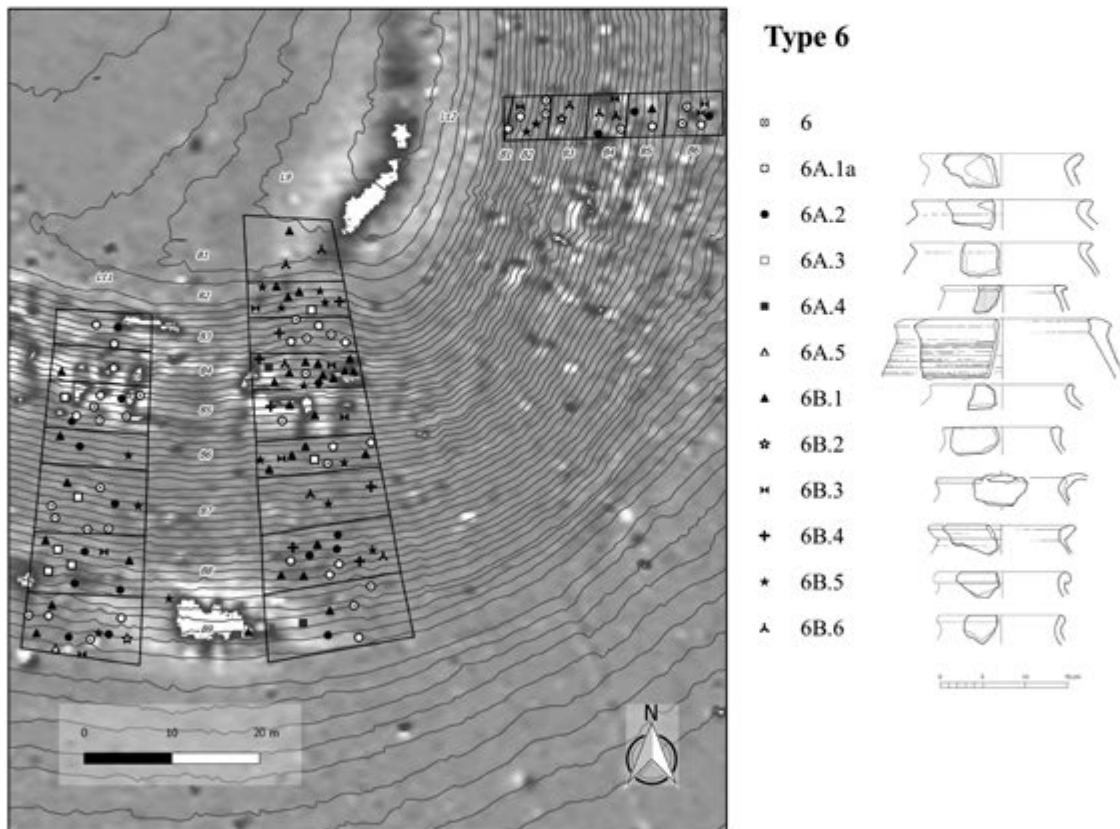
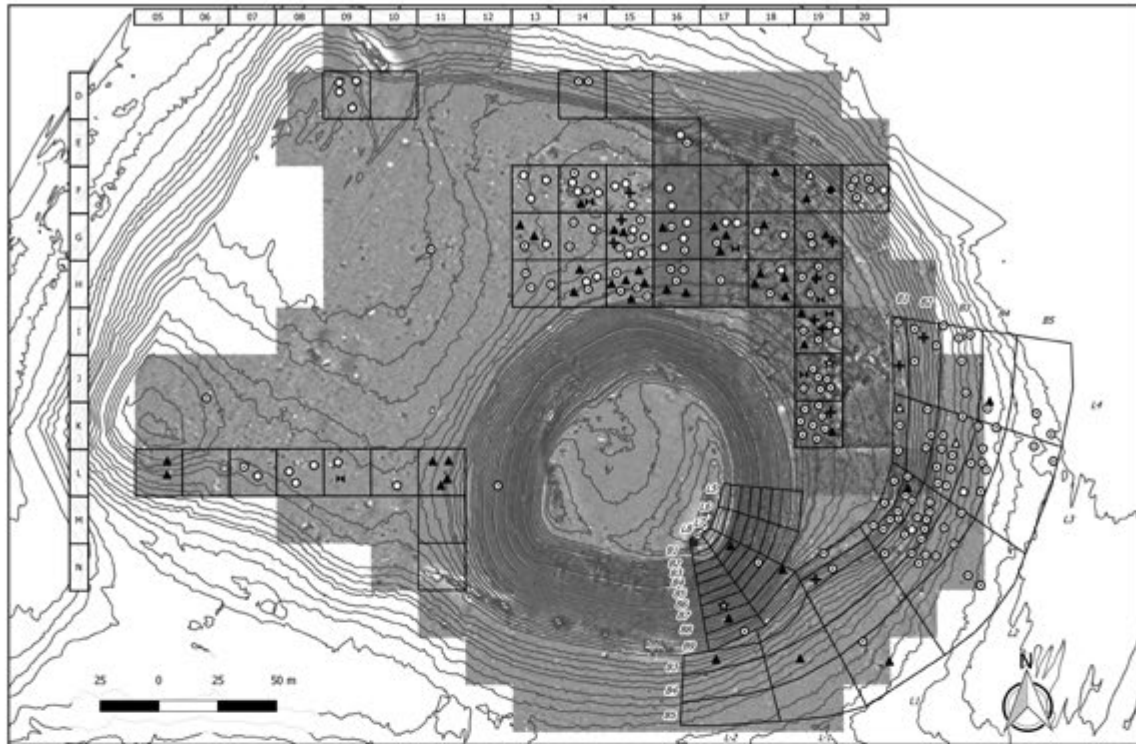


Fig. 54 – Uşaklı Höyük, scatter of ceramic artifacts (diagnostic types).

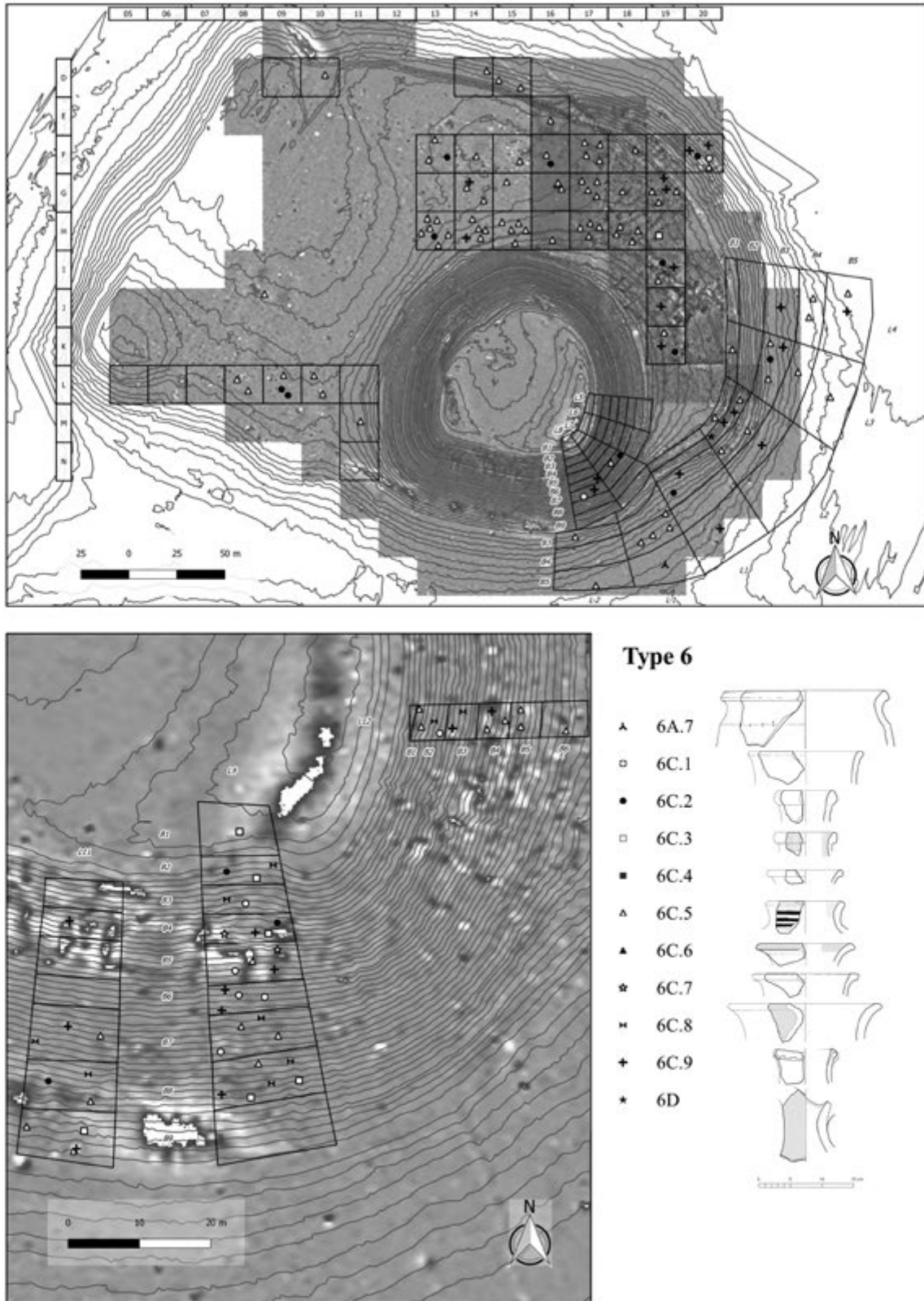


Fig. 55 – Uşaklı Höyük, scatter of ceramic artifacts (diagnostic types).

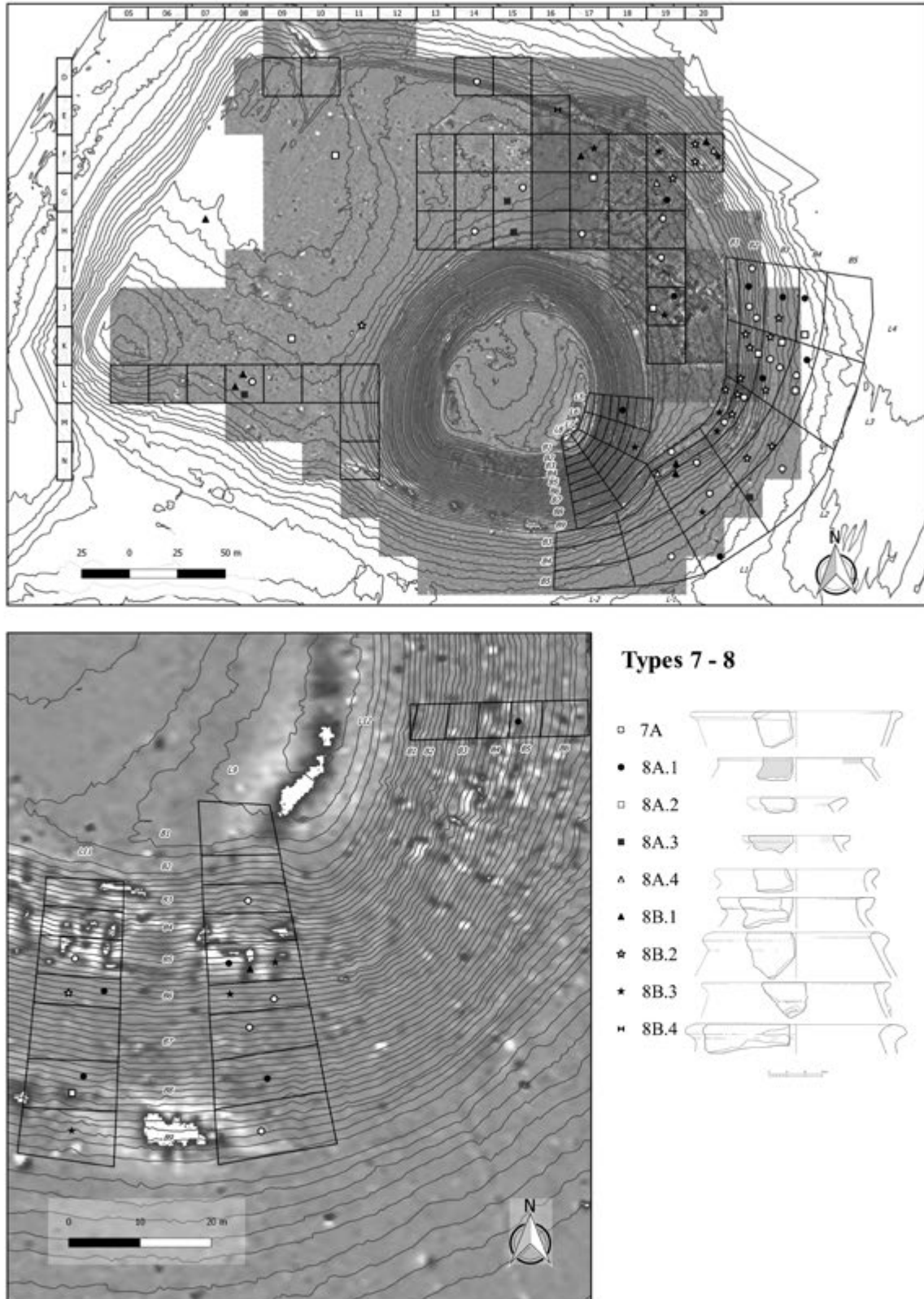


Fig. 56 – Uşaklı Höyük, scatter of ceramic artifacts (diagnostic types).

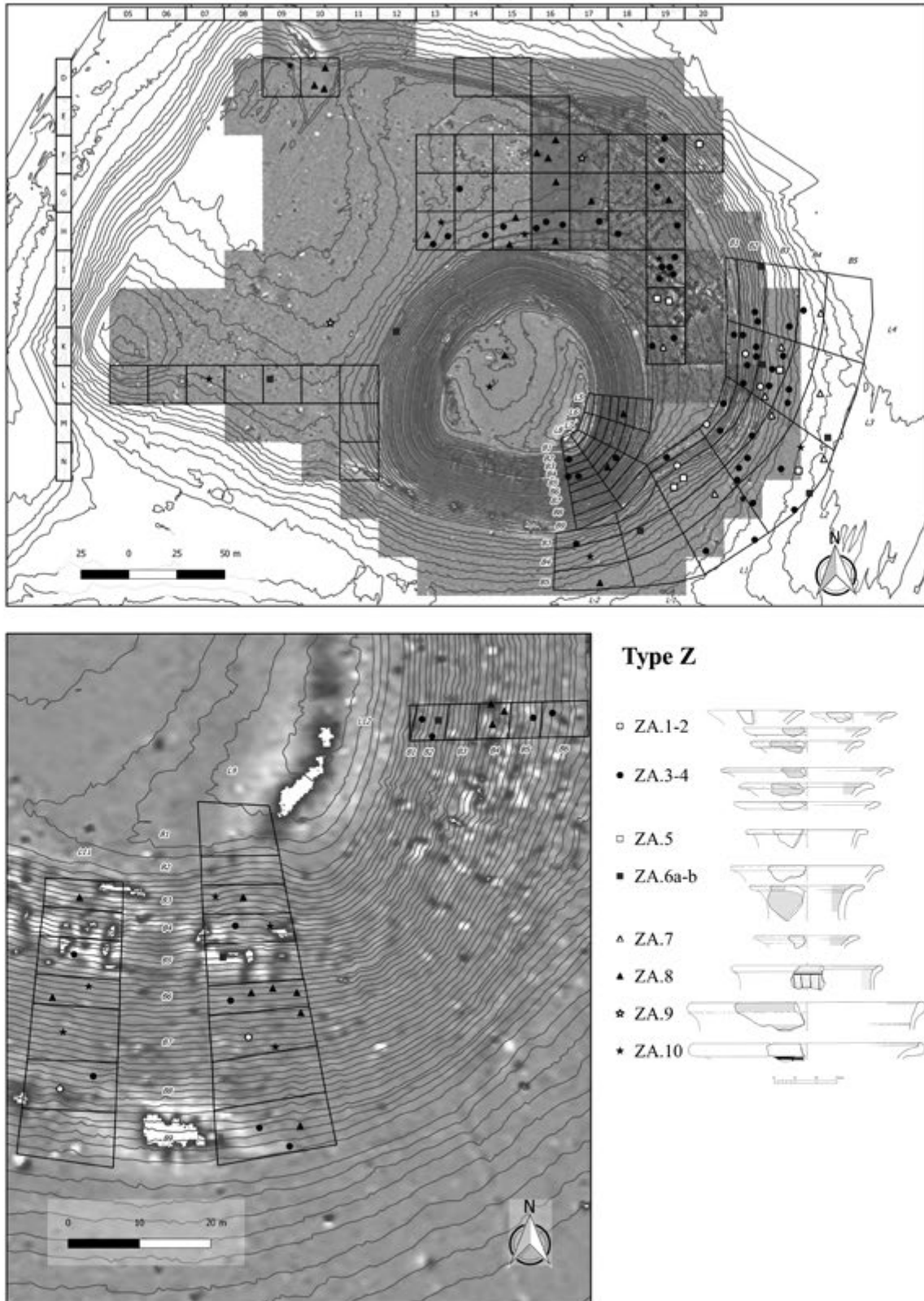


Fig. 57 – Uşaklı Höyük, scatter of ceramic artifacts (diagnostic types).

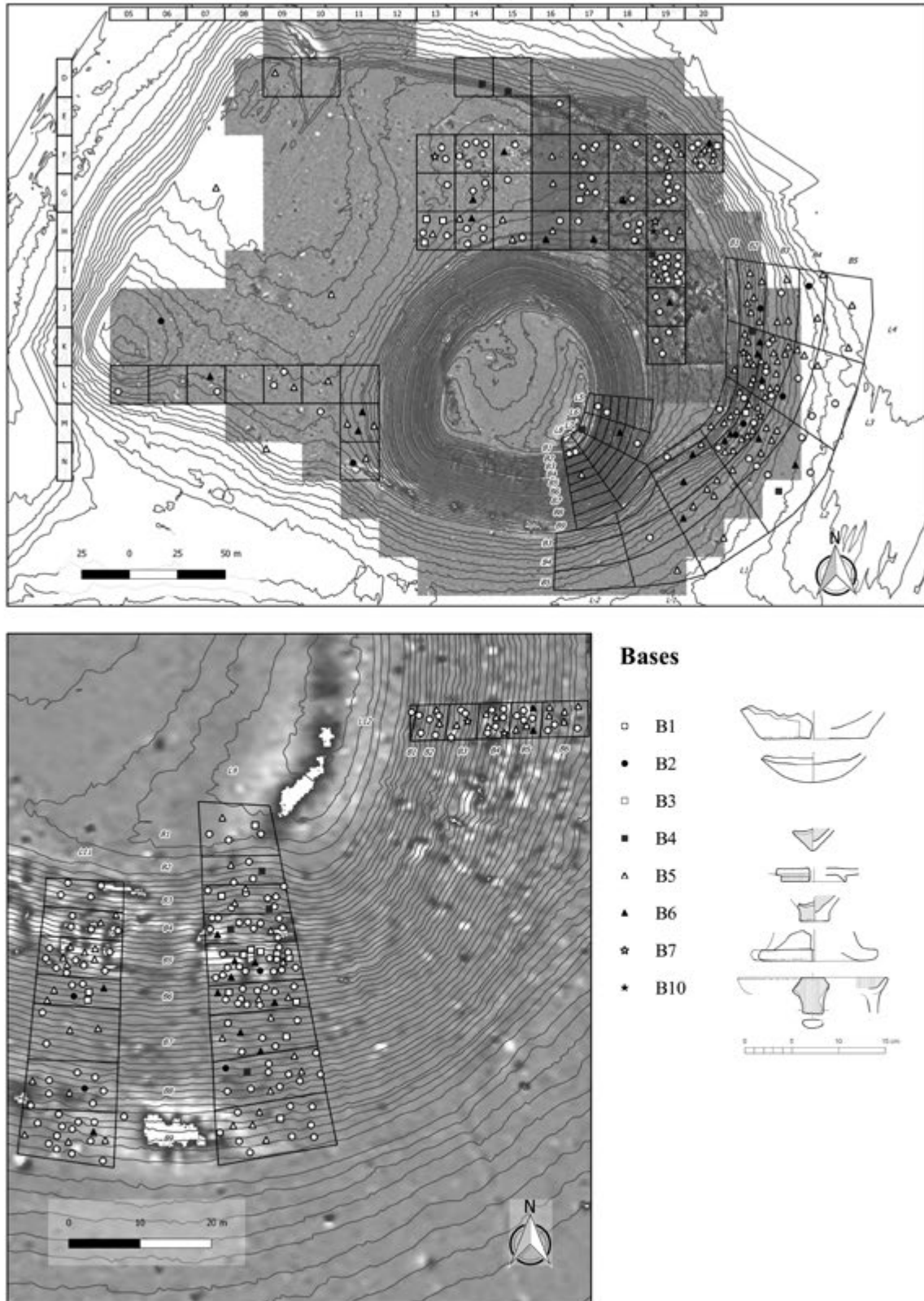


Fig. 58 – Uşaklı Höyük, scatter of ceramic artifacts (diagnostic types).

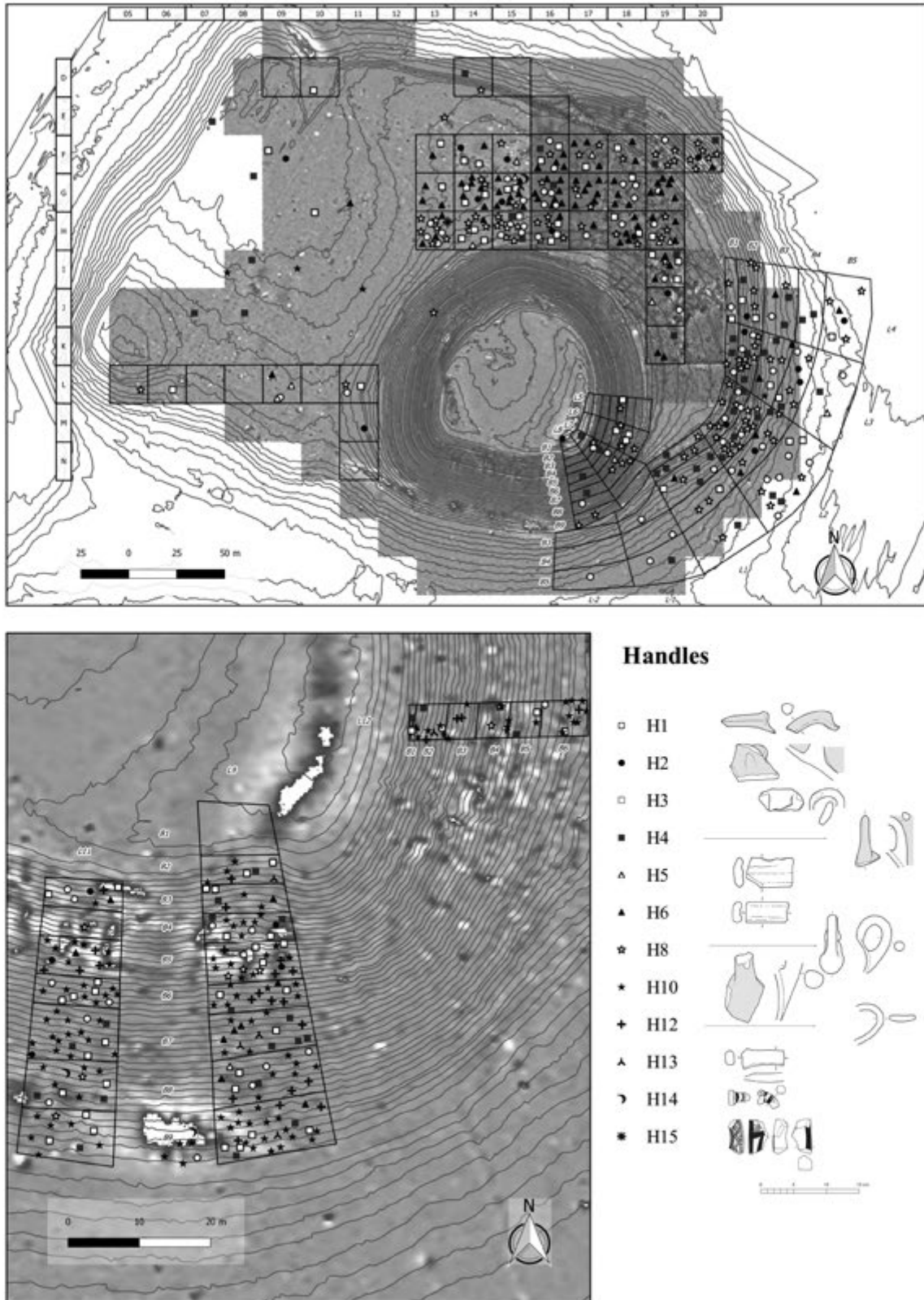
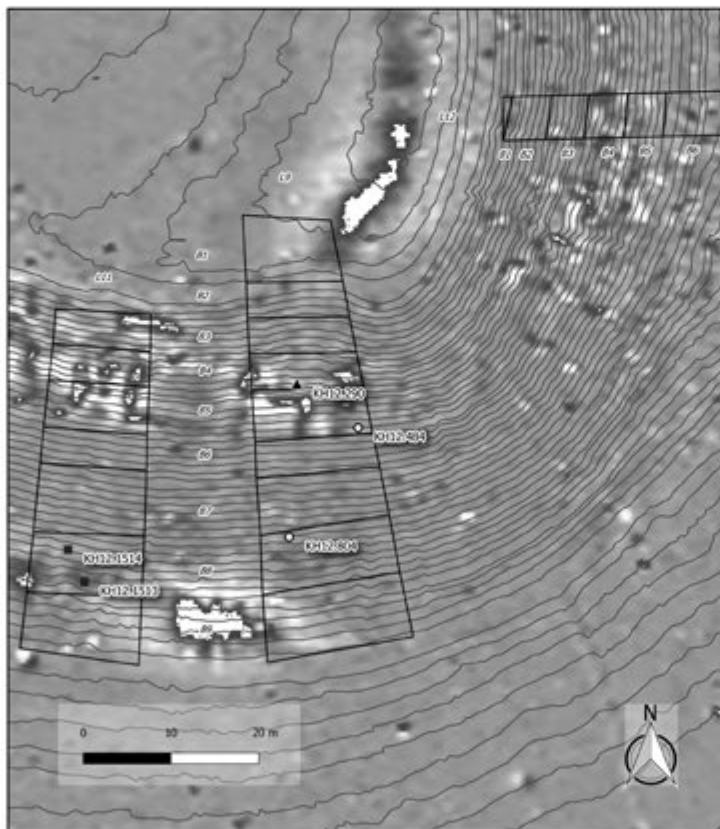
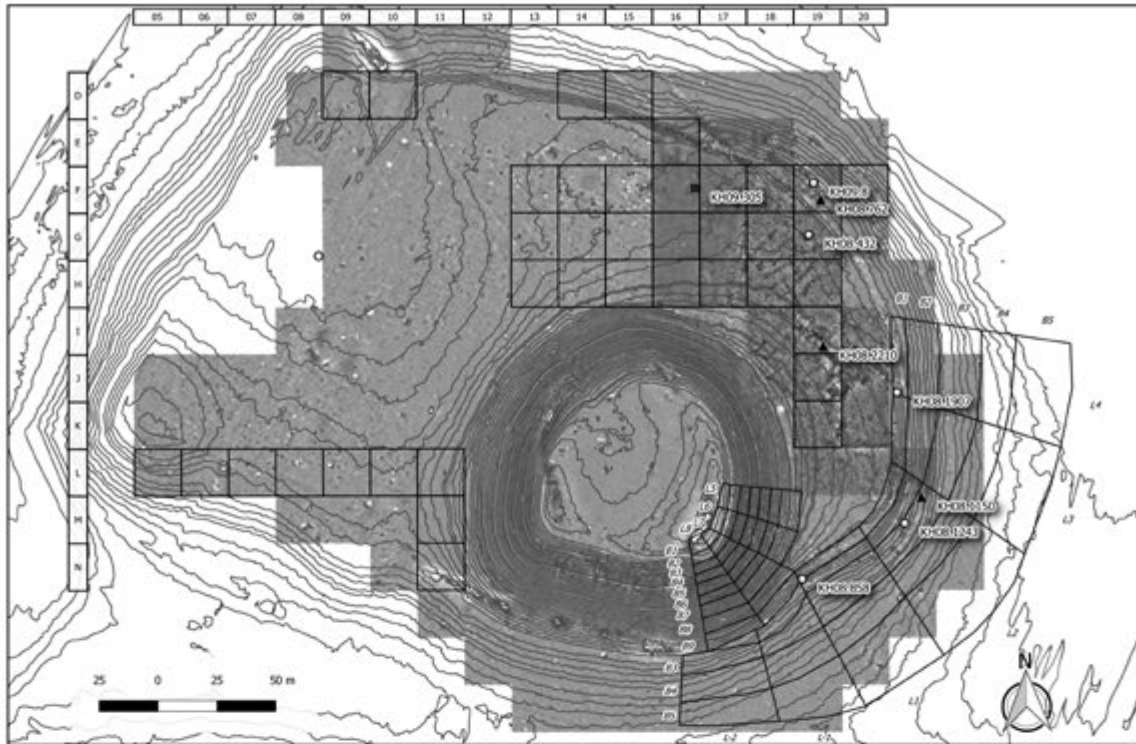


Fig. 59 – Uşaklı Höyük, scatter of ceramic artifacts (diagnostic types).



Body sherds with impressed and incised marks

- Impressed
- Incised
- ▲ Applied and incised

Fig. 60 – Uşaklı Höyük, scatter of ceramic artifacts (diagnostic types).

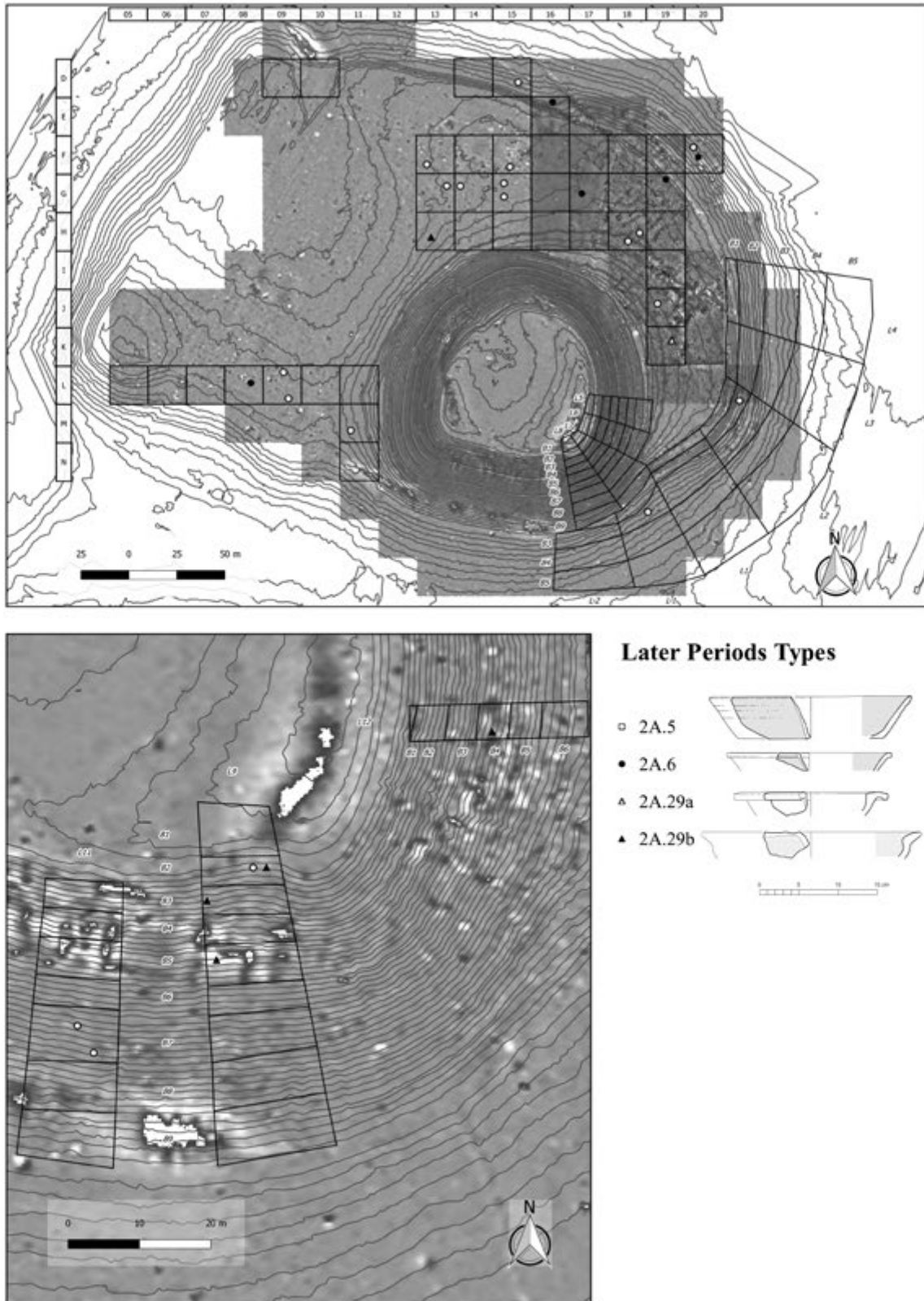


Fig. 61 – Uşaklı Höyük, scatter of ceramic artifacts (diagnostic types).

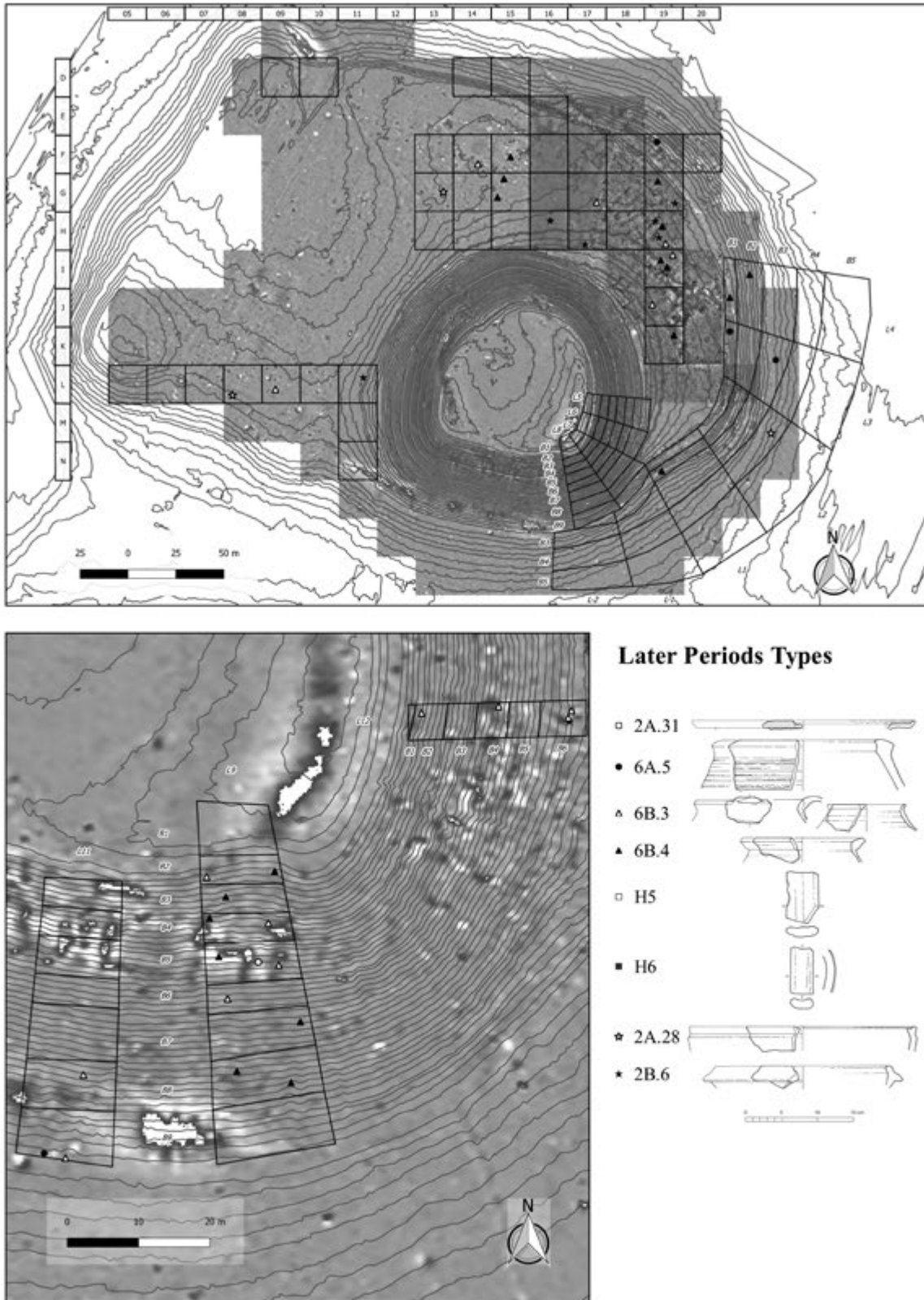


Fig. 62 – Uşaklı Höyük, scatter of ceramic artifacts (diagnostic types).

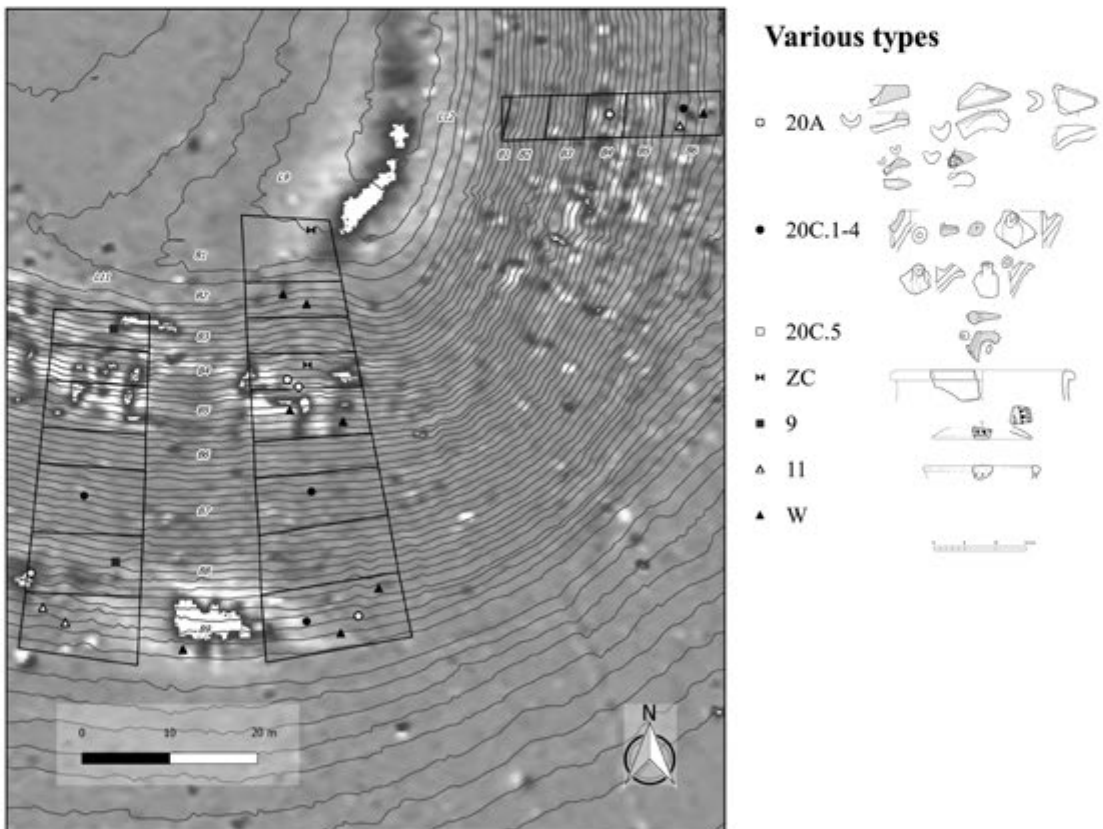
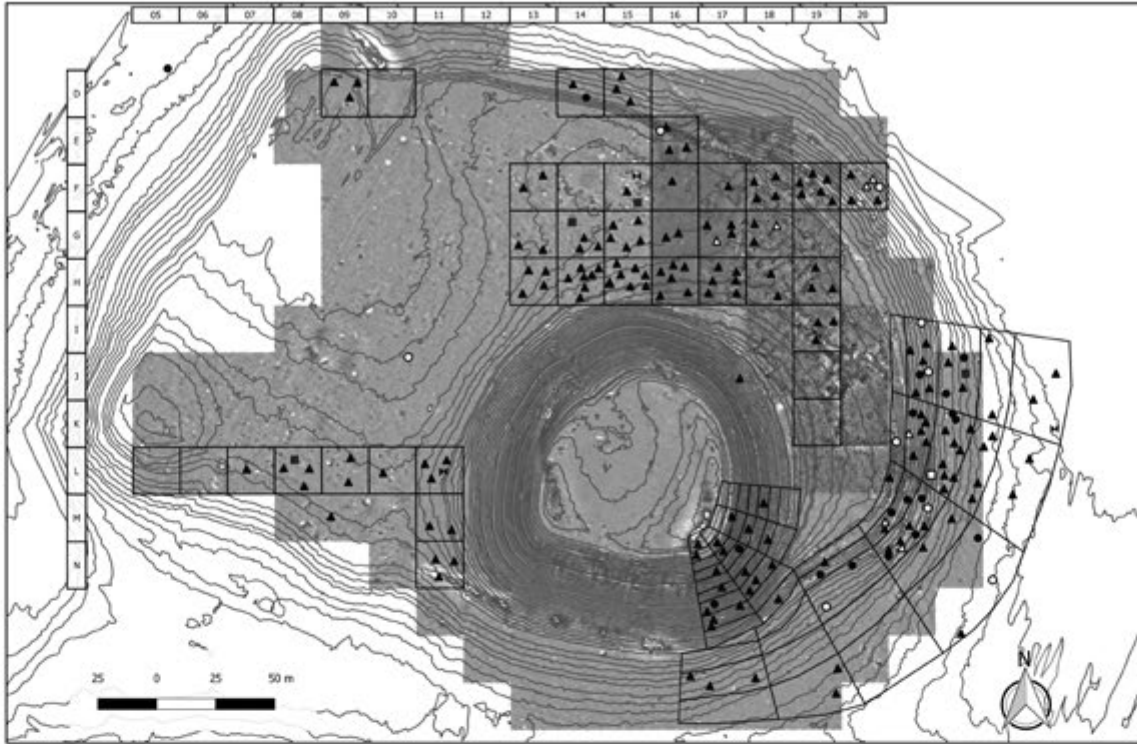


Fig. 63 – Uşaklı Höyük, scatter of ceramic artifacts (diagnostic types).

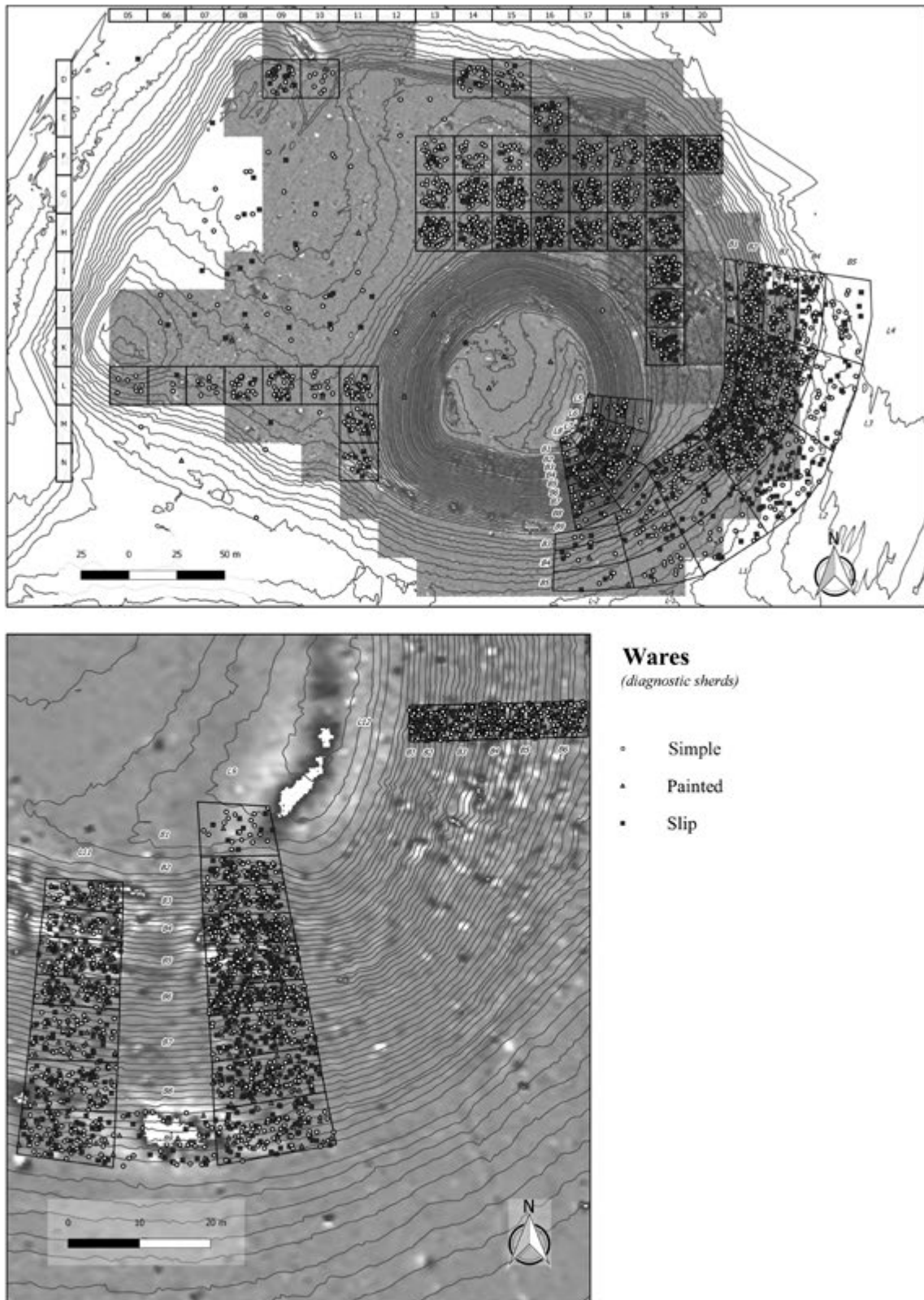
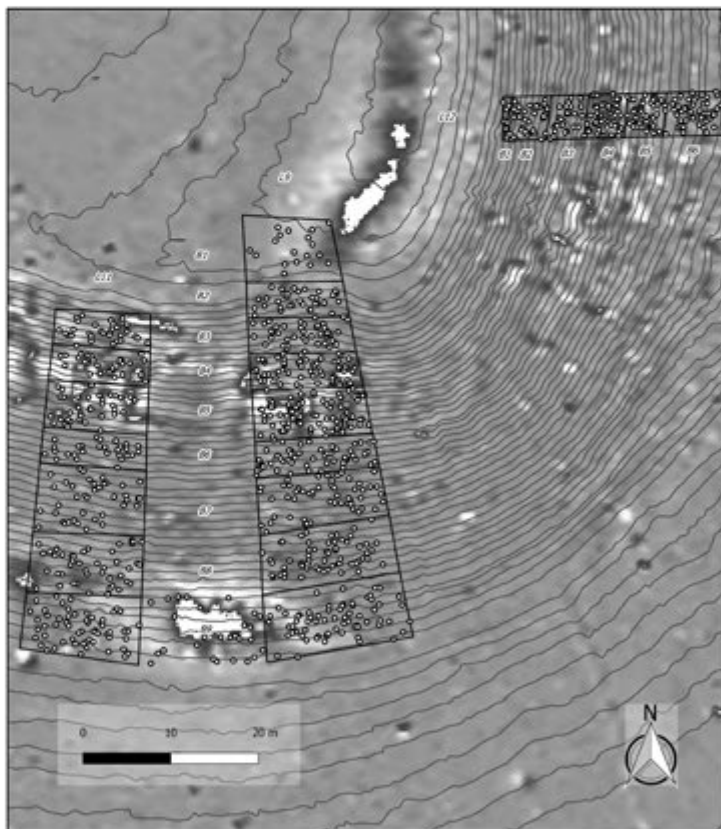
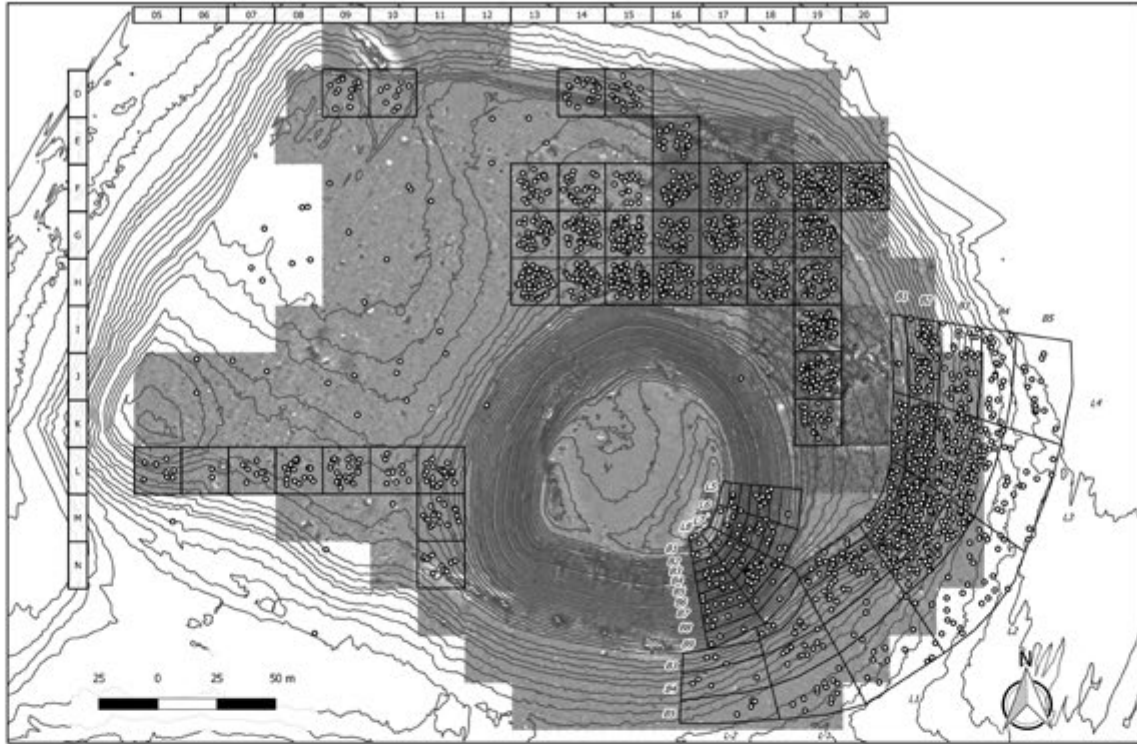
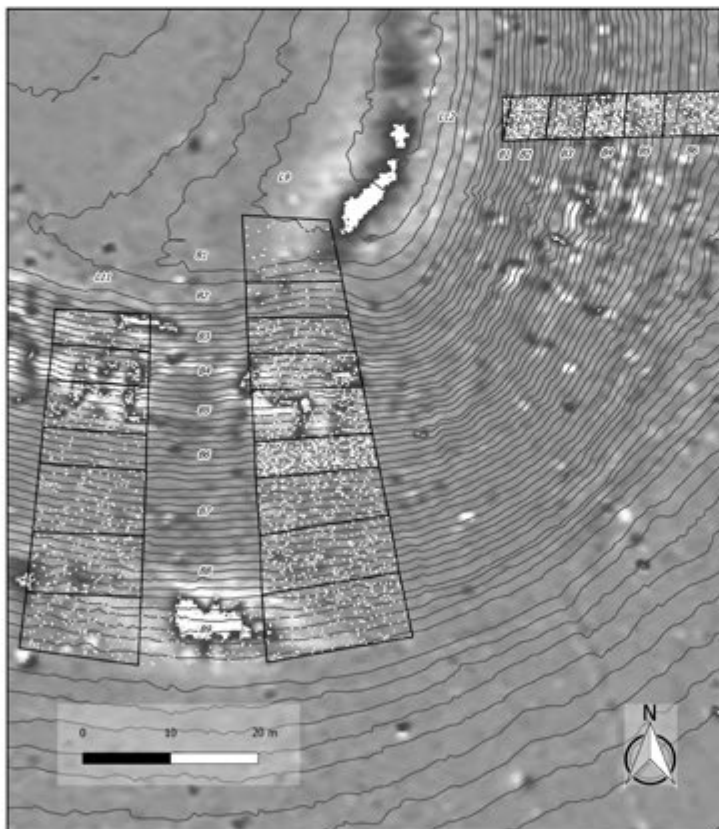
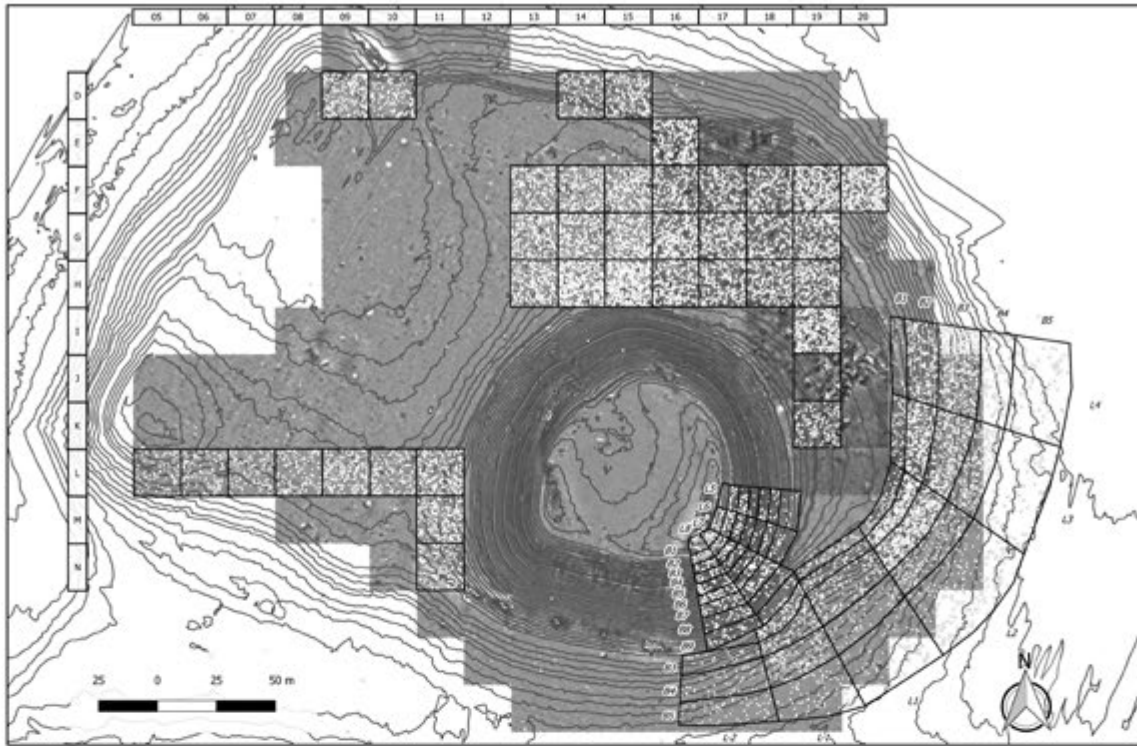


Fig. 64 – Uşaklı Höyük, scatter of wares (diagnostic types).



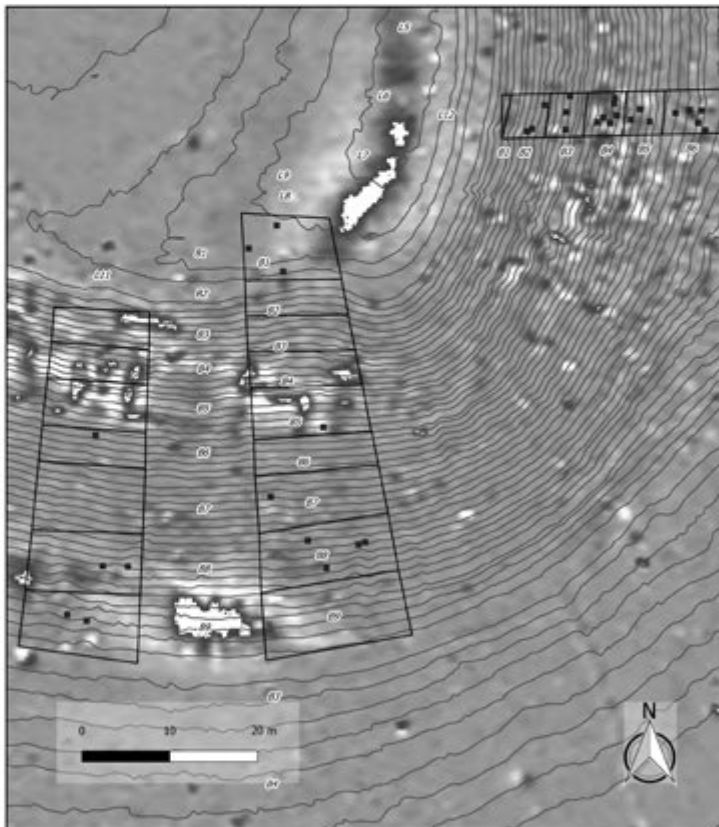
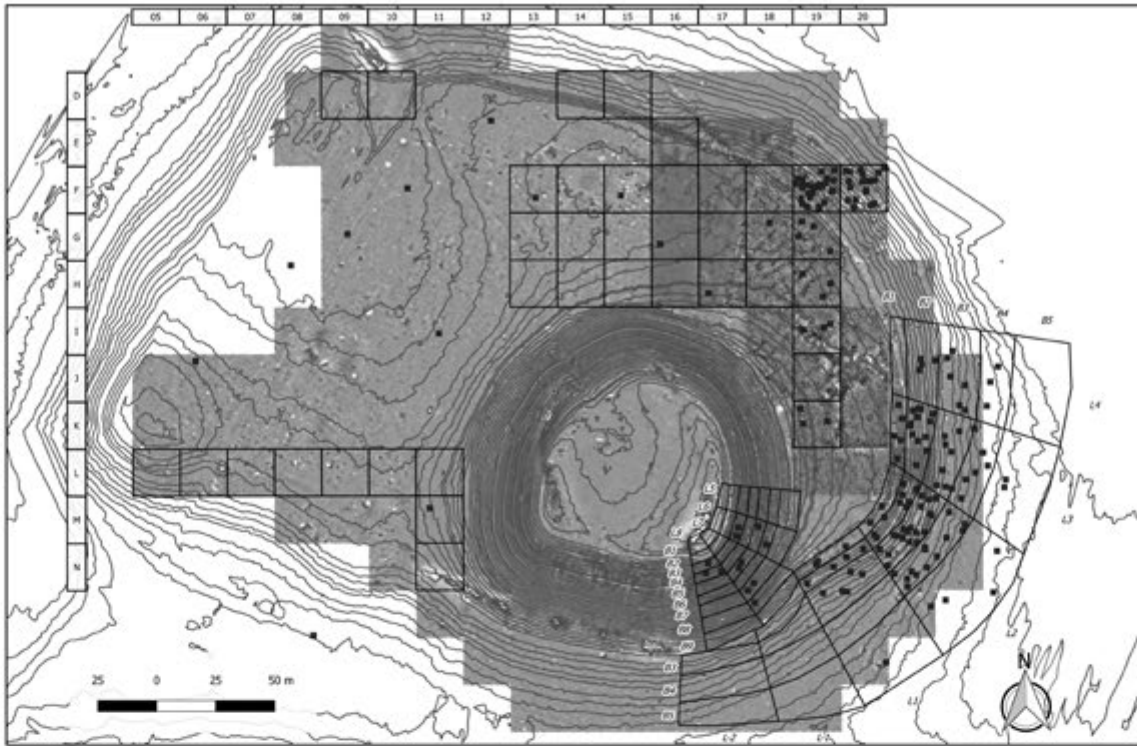
Simple wares
(diagnostic sherds)

Fig. 65 – Uşaklı Höyük, scatter of wares (diagnostic types).



Plain ware
(generic sherds)

Fig. 66 – Uşaklı Höyük, scatter of wares (generic types).



Drab ware
(diagnostic sherds)

Fig. 67 – Uşaklı Höyük, scatter of wares (diagnostic types).

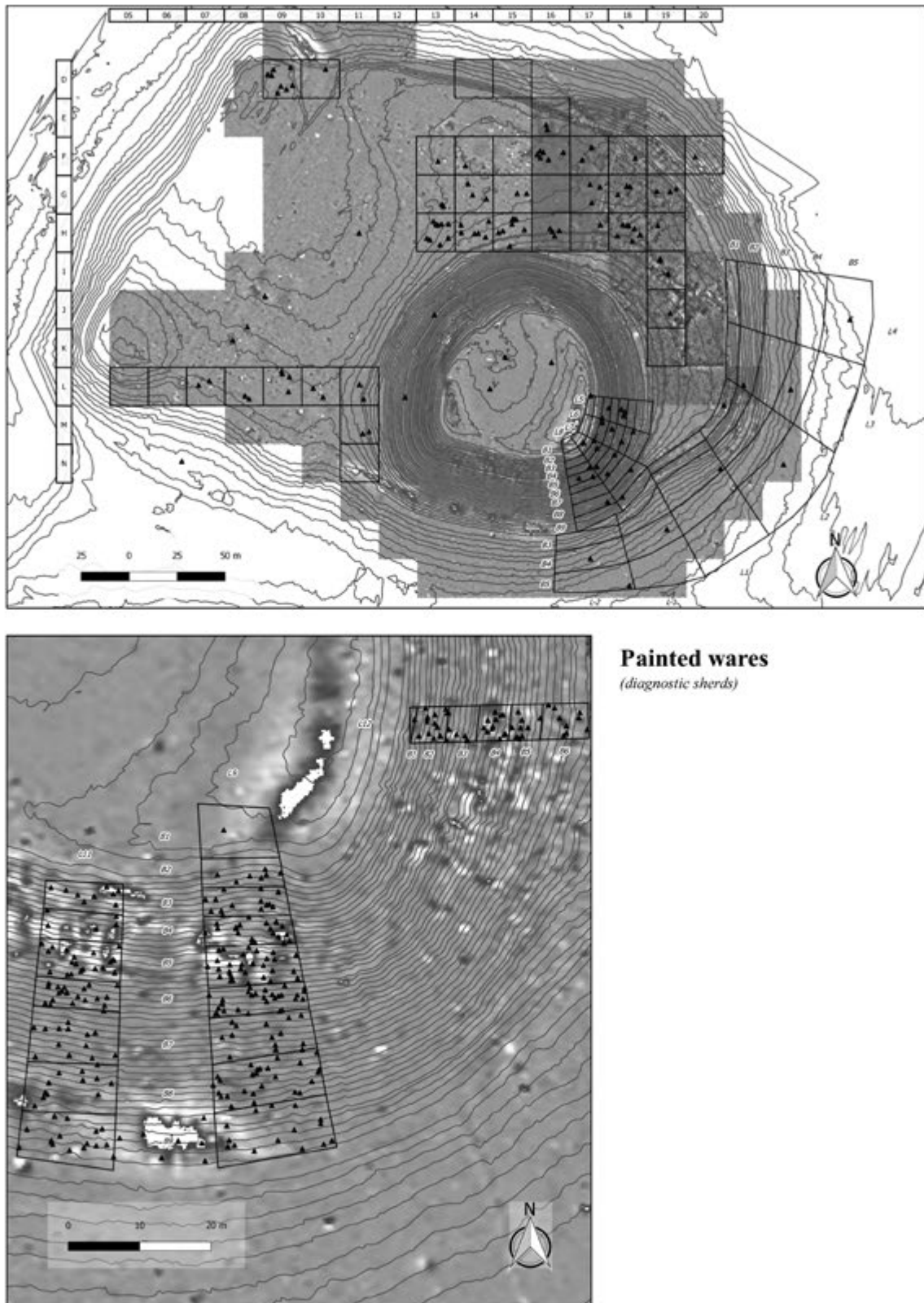
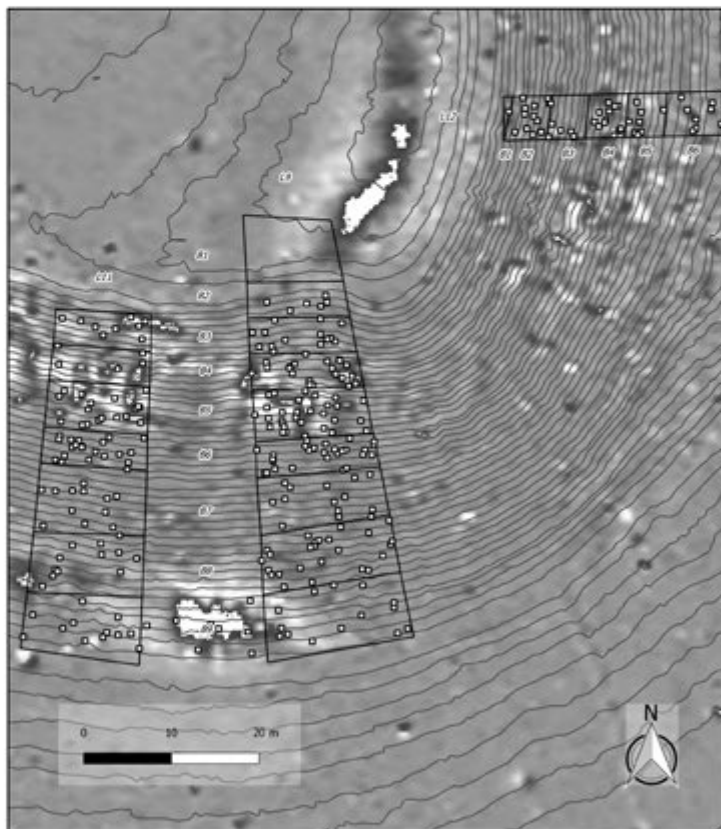
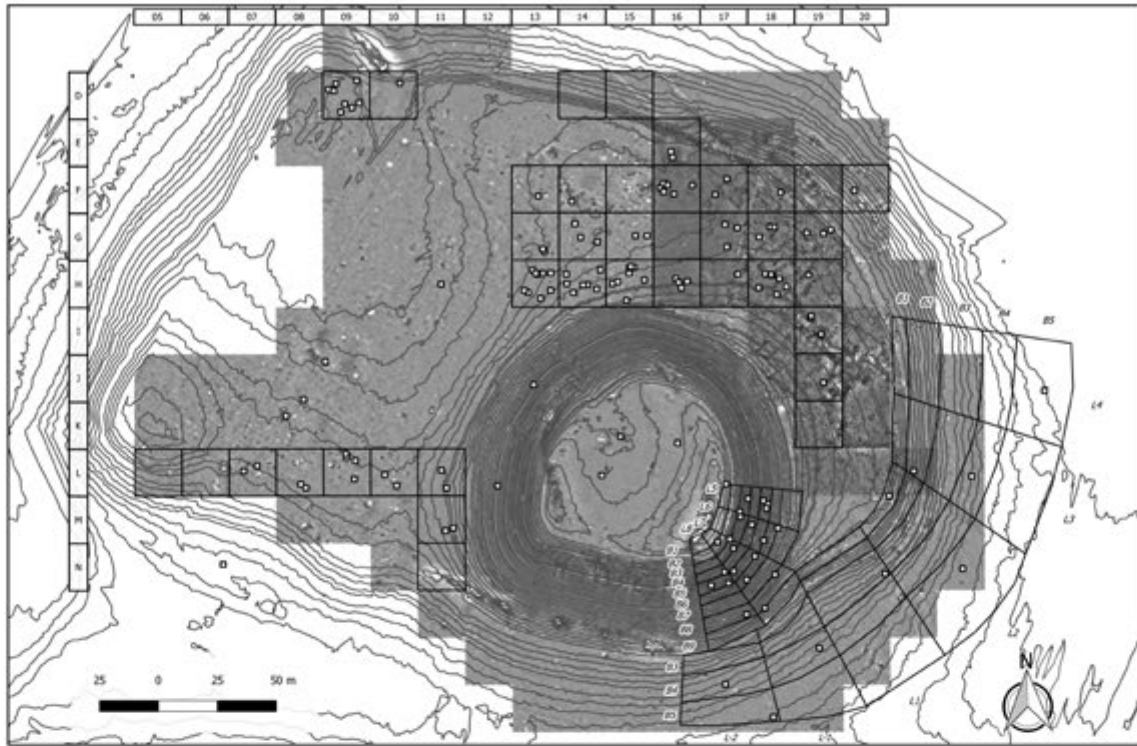
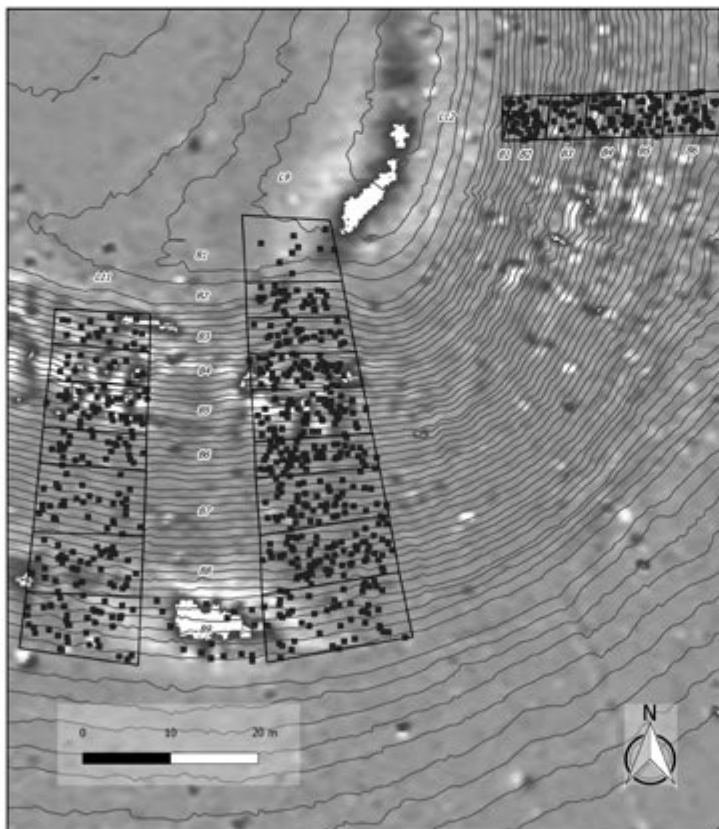
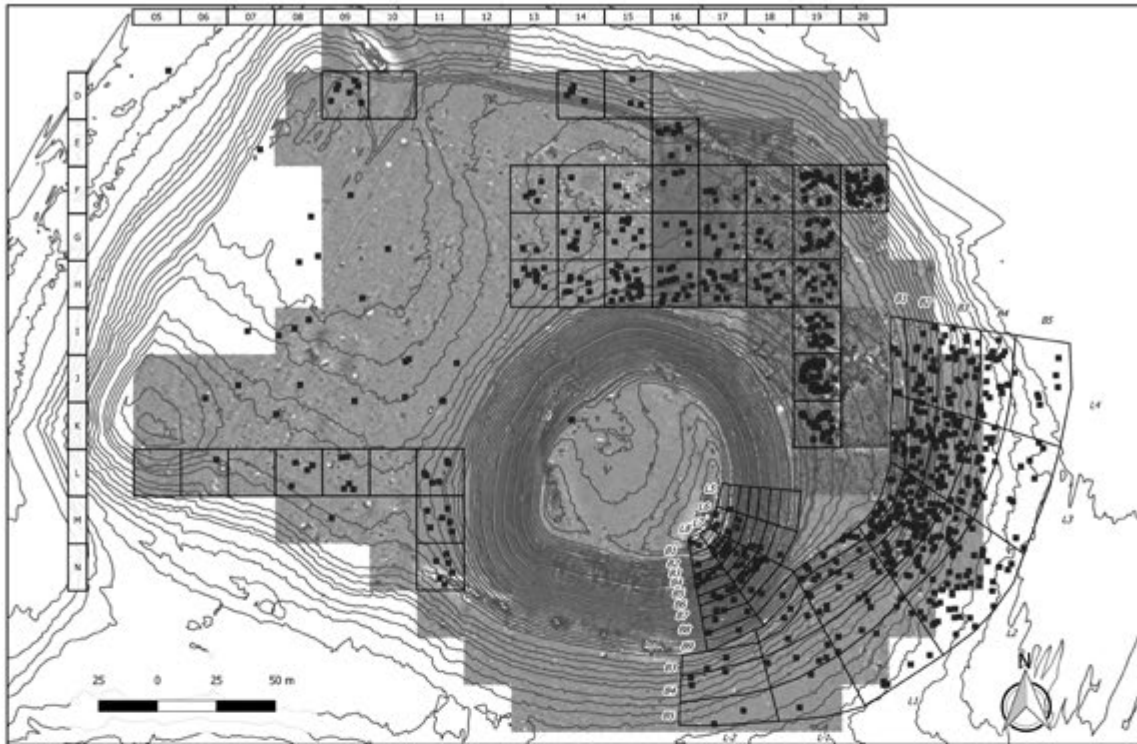


Fig. 68 – Uşaklı Höyük, scatter of wares (diagnostic types).



Iron Age Painted wares
(diagnostic sherds)

Fig. 69 – Uşaklı Höyük, scatter of wares (diagnostic types).



Slipped wares
(diagnostic sherds)

Fig. 70 – Uşaklı Höyük, scatter of wares (diagnostic types).

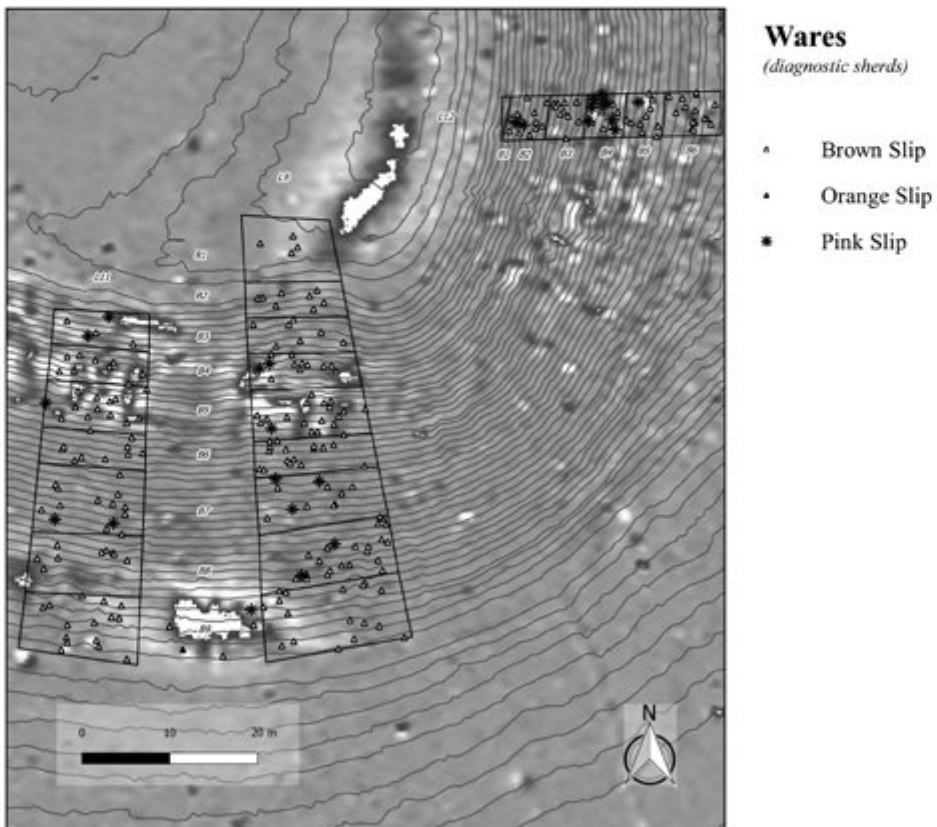
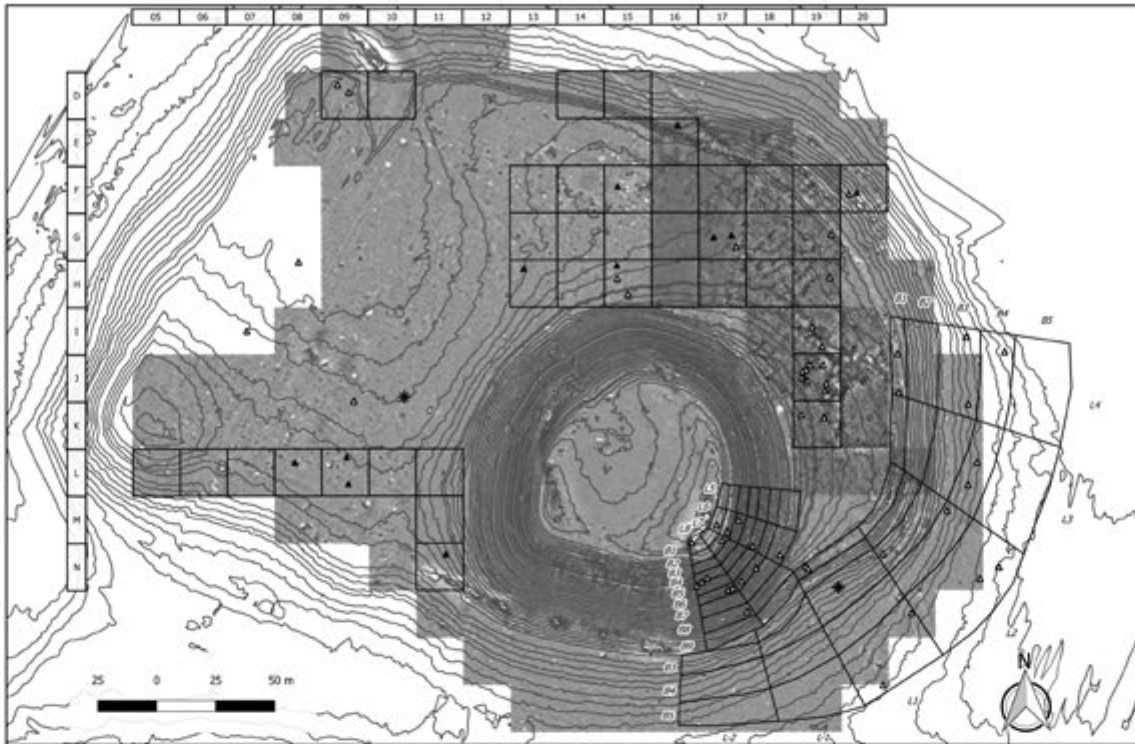


Fig. 71 – Uşaklı Höyük, scatter of wares (diagnostic types).

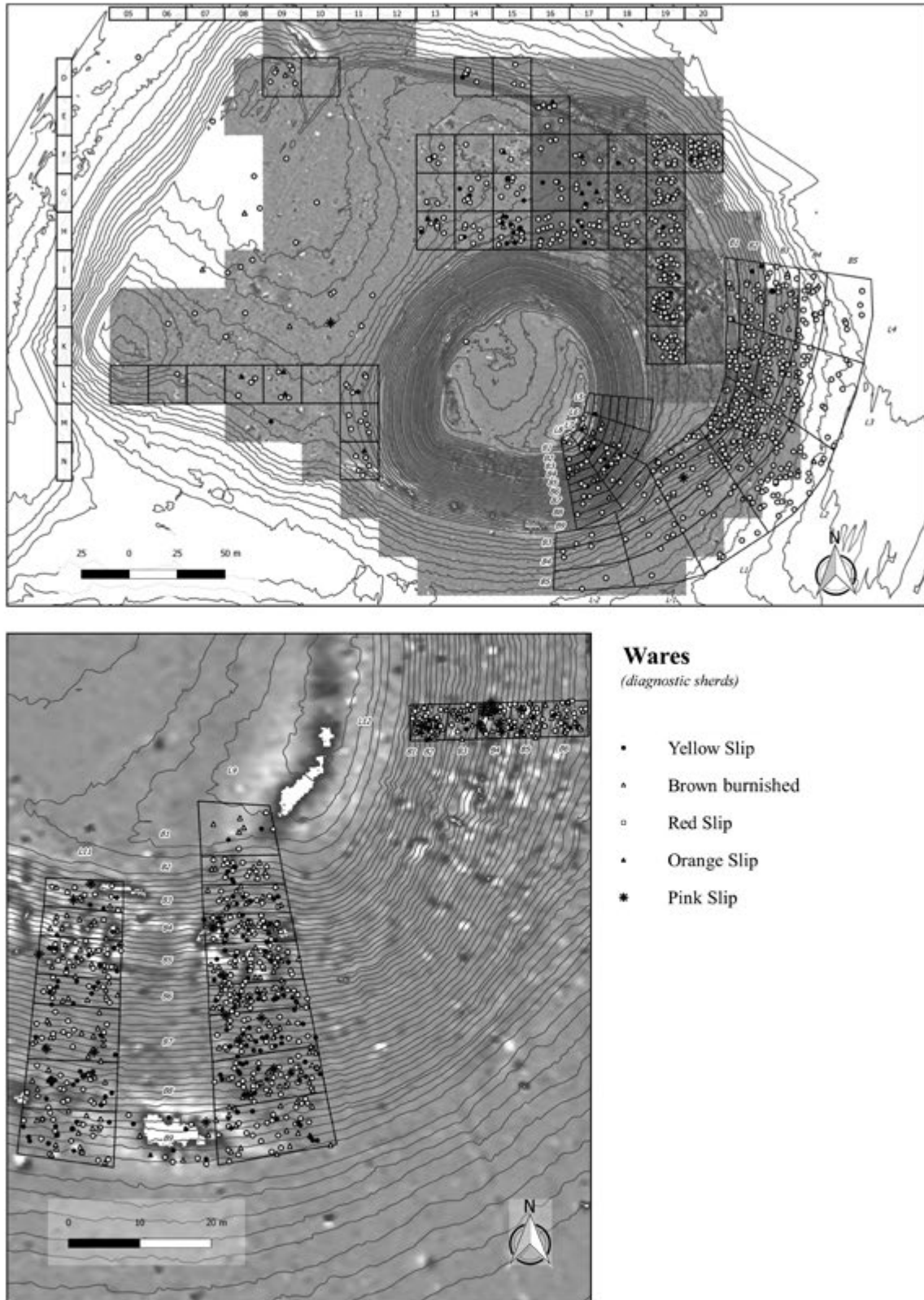
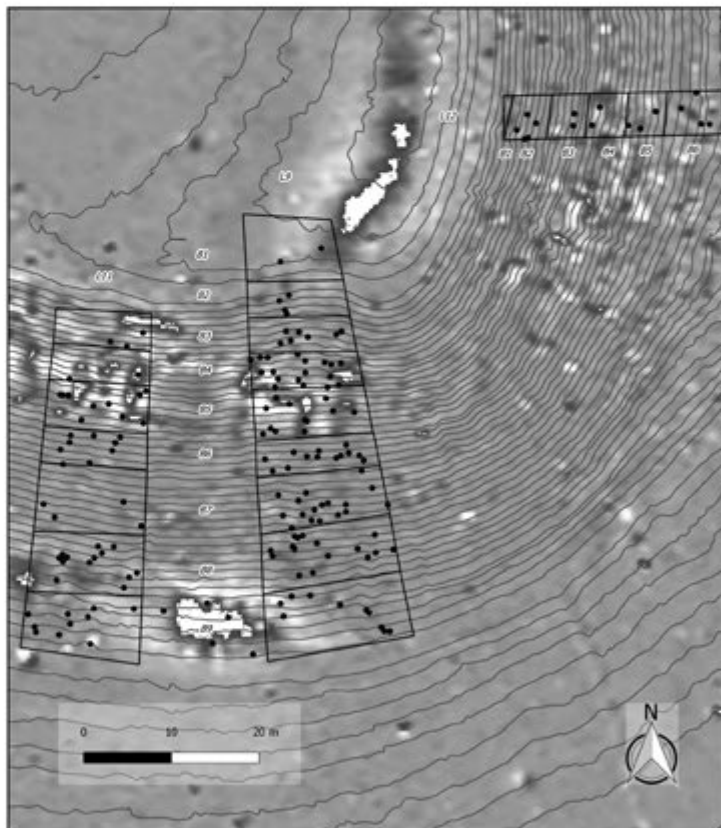
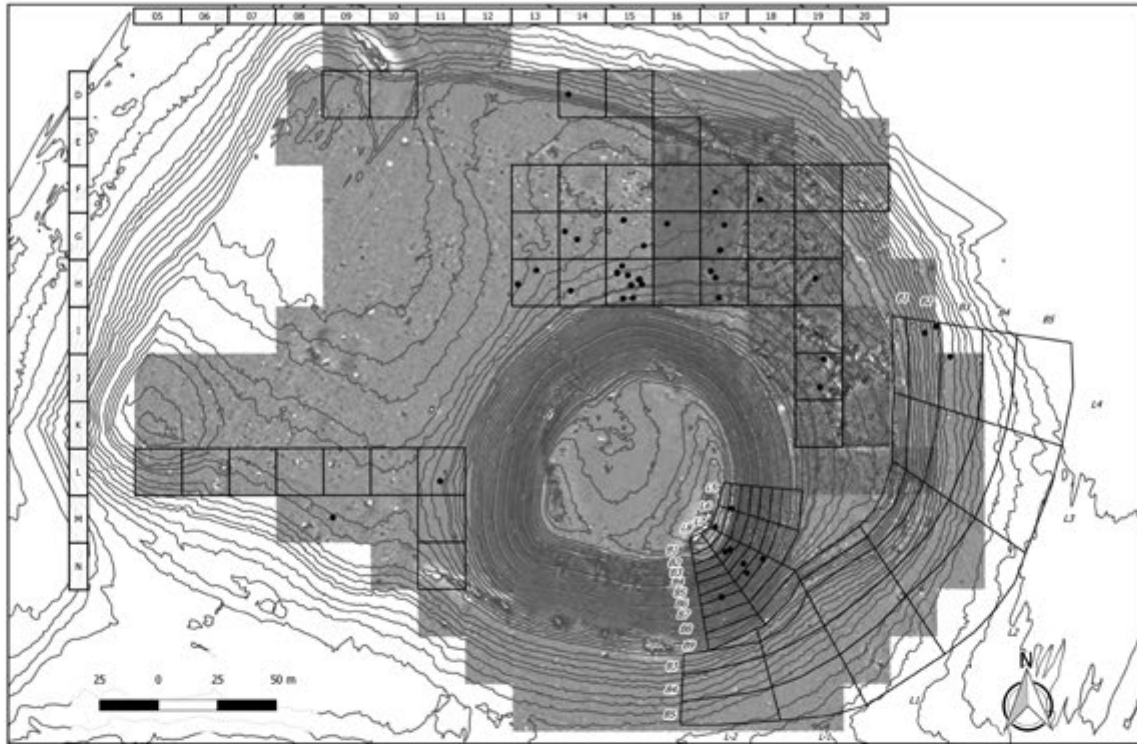


Fig. 72 – Uşaklı Höyük, scatter of wares (diagnostic types).



Yellow Slip
(diagnostic sherds)

Fig. 73 – Uşaklı Höyük, scatter of wares (diagnostic types).

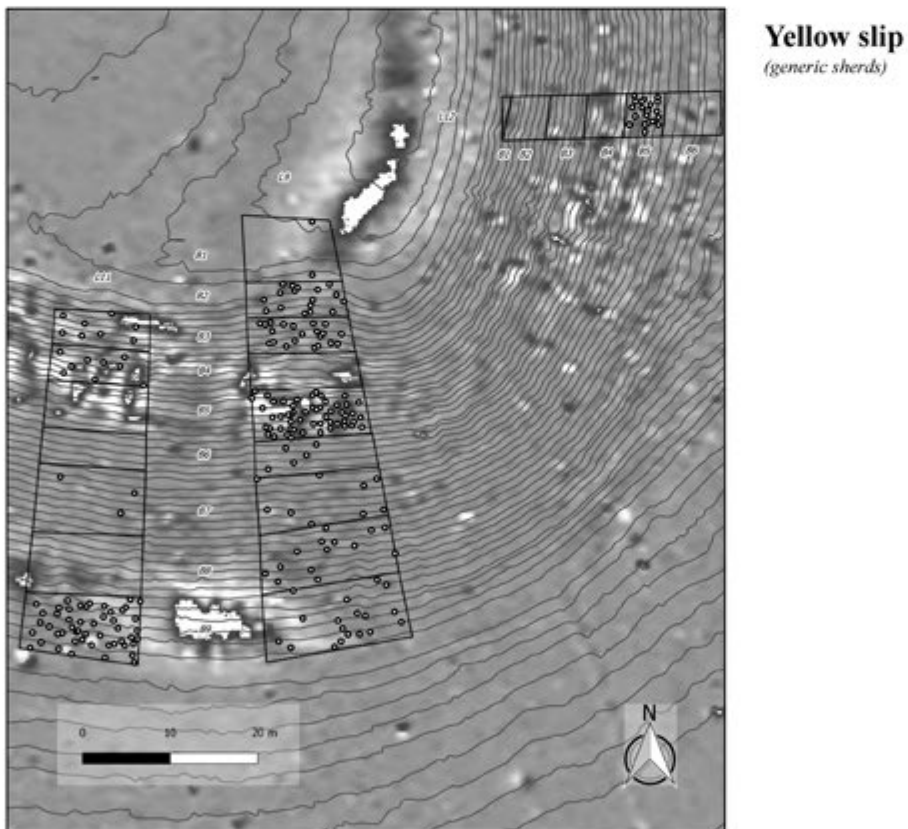
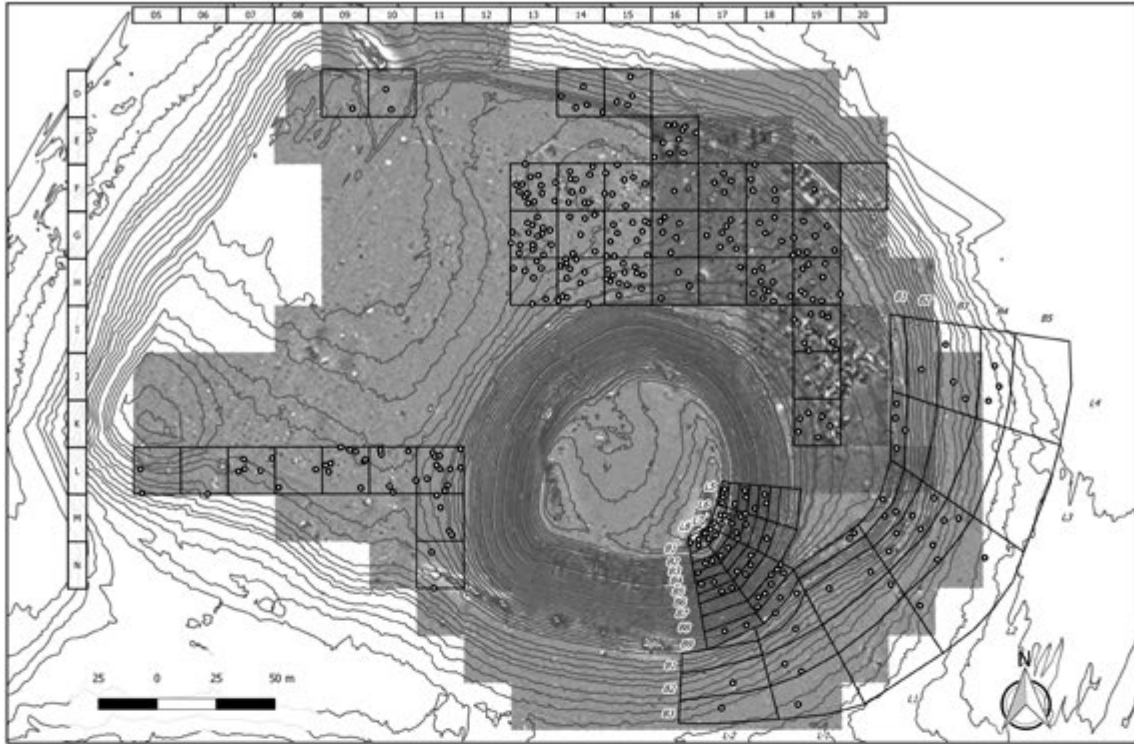
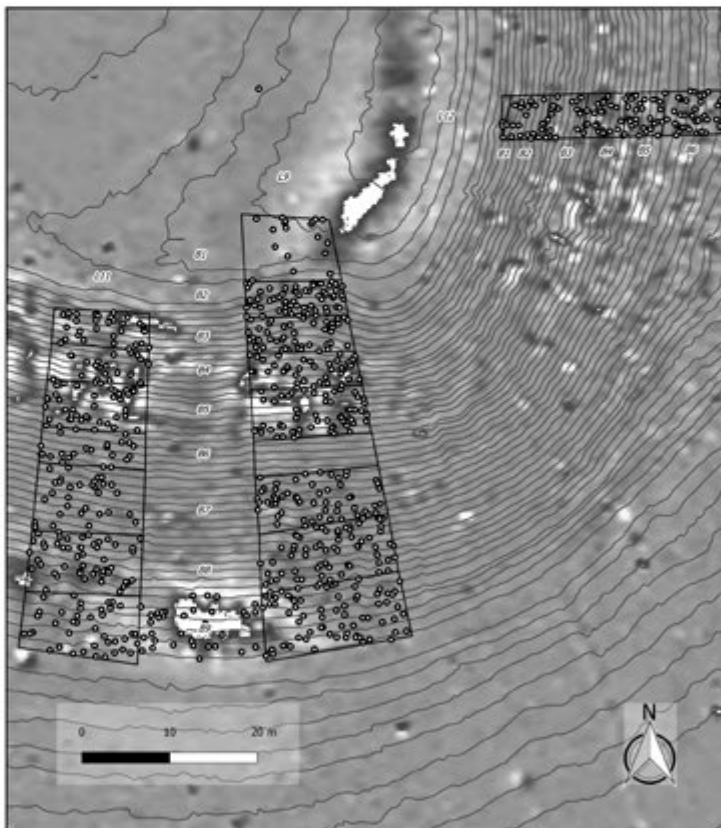
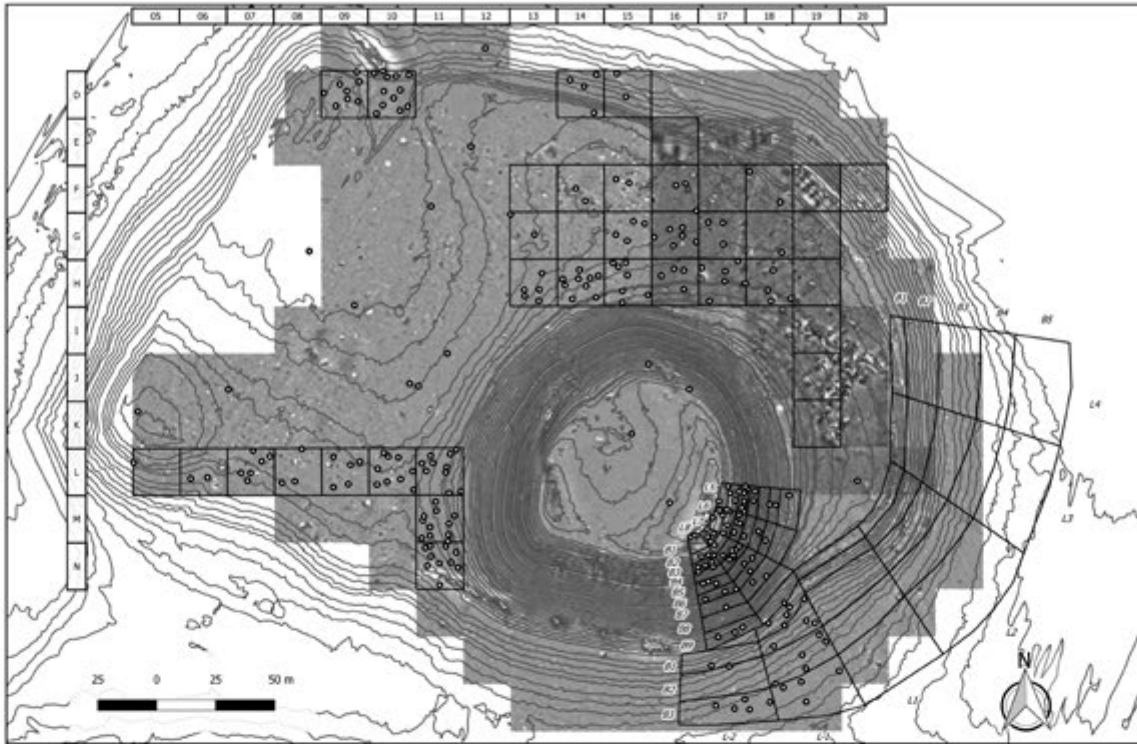


Fig. 74 – Uşaklı Höyük, scatter of wares (generic types).

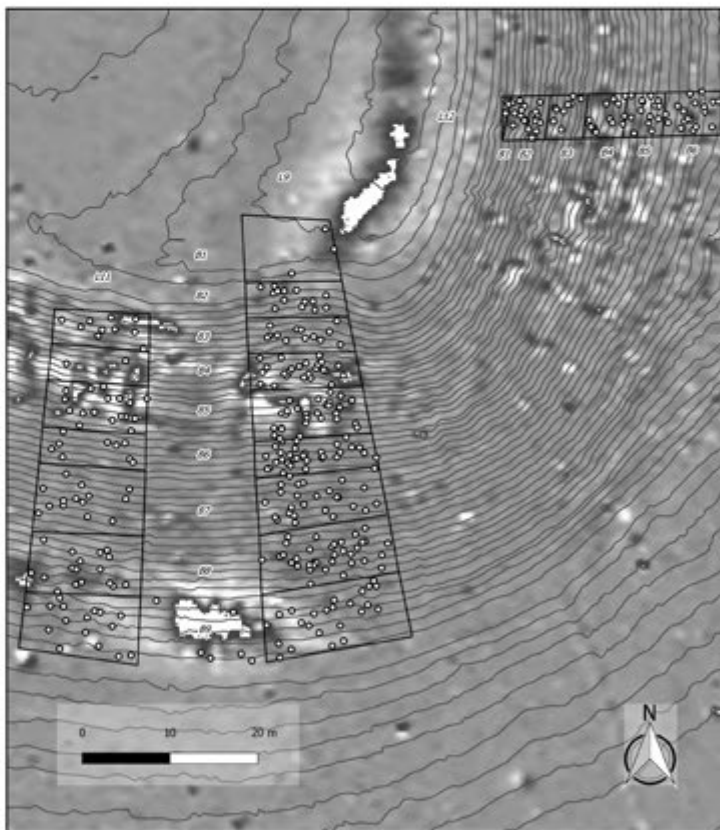
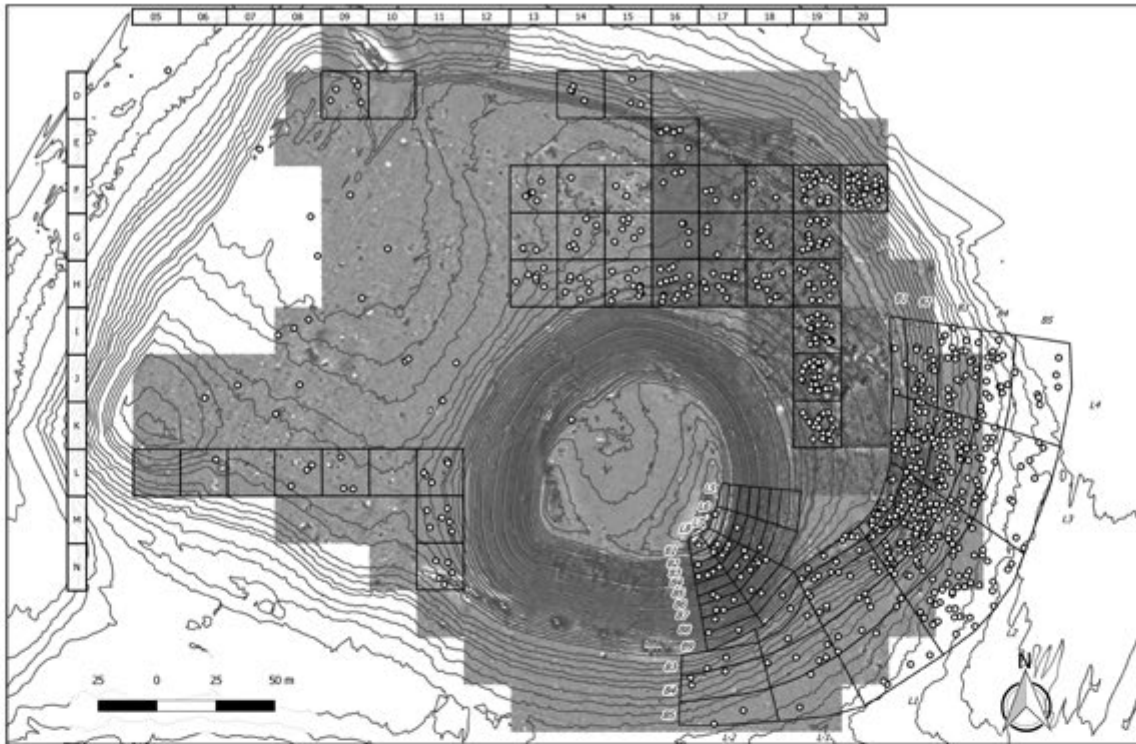


Yellow slip - Iron Age
(generic sherds)

Fig. 75 – Uşaklı Höyük, scatter of wares (generic types).

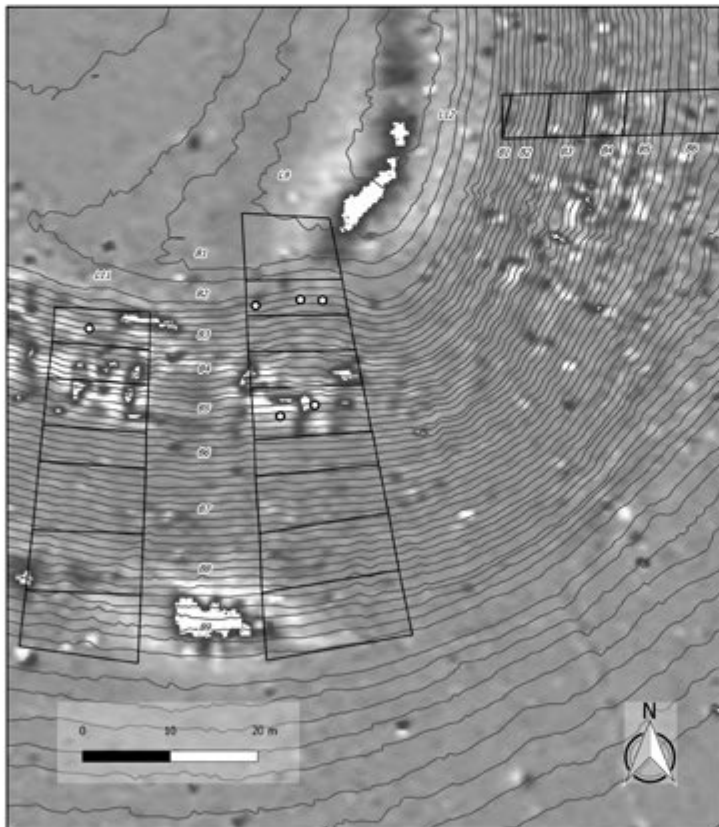
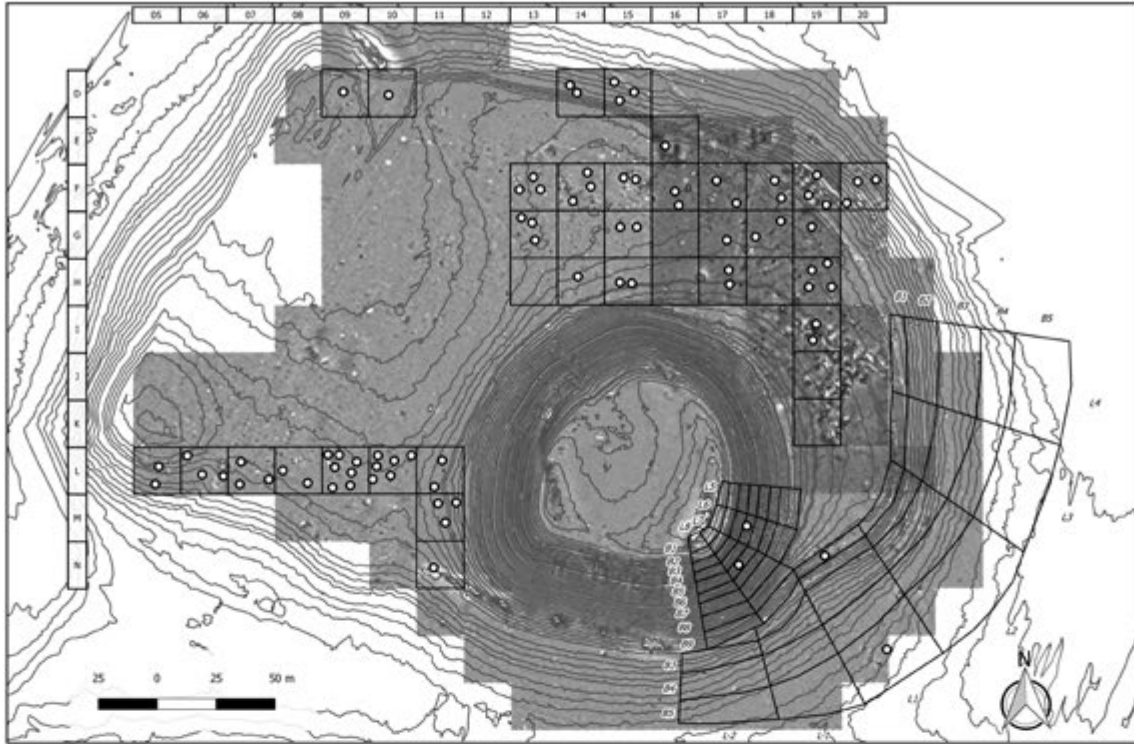


Fig. 76 – Uşaklı Höyük, scatter of wares (generic types).



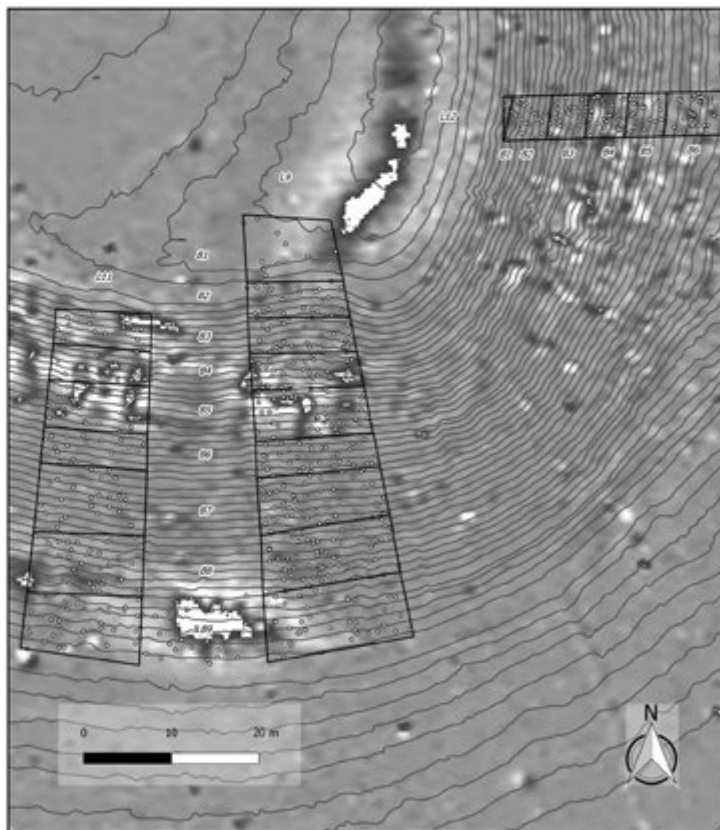
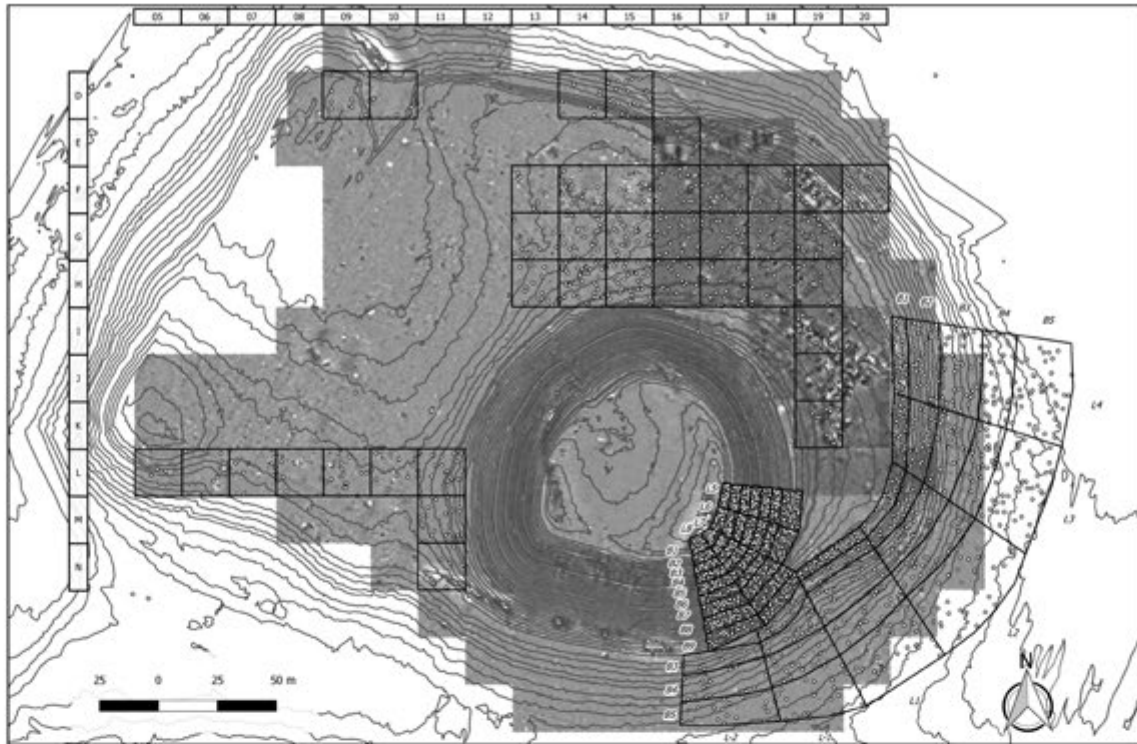
Red Slip
(diagnostic sherds)

Fig. 77 – Uşaklı Höyük, scatter of wares (diagnostic types).



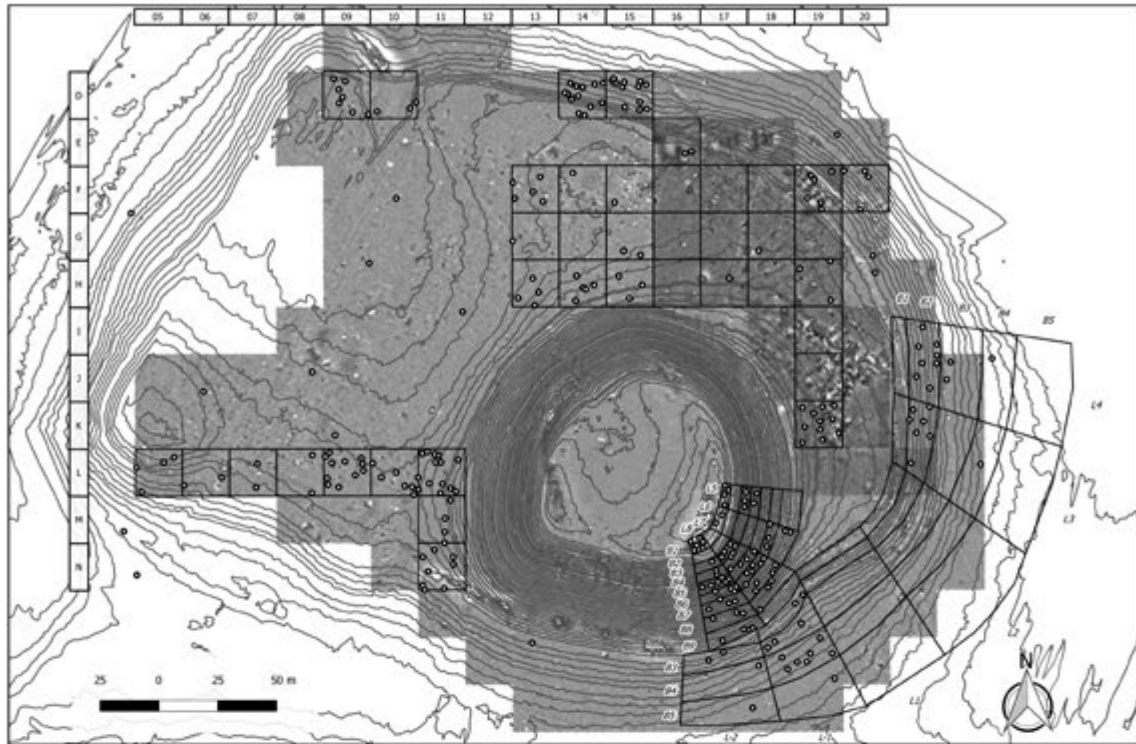
Orange slip
(generic sherds)

Fig. 78 – Uşaklı Höyük, scatter of wares (generic types).



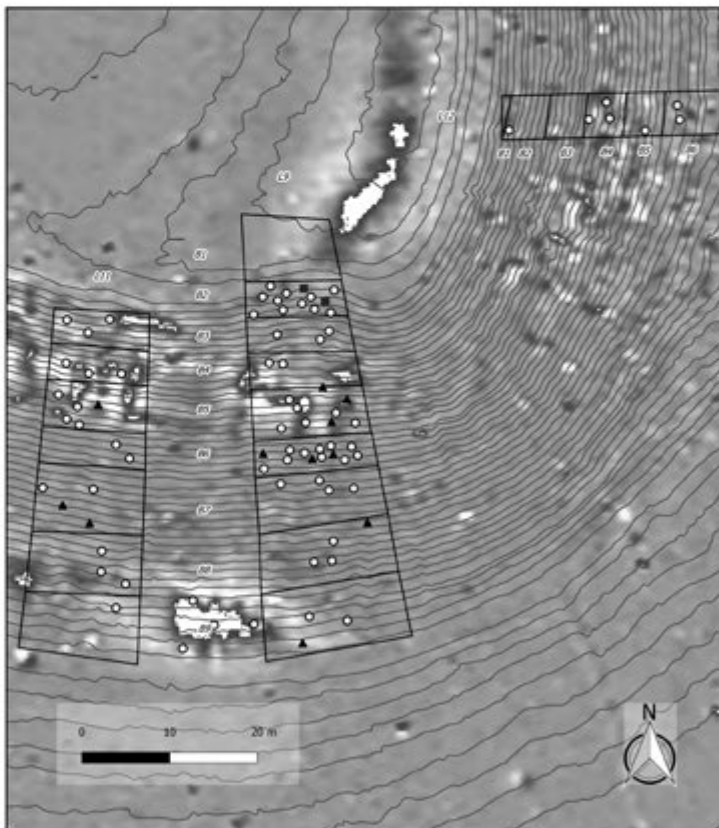
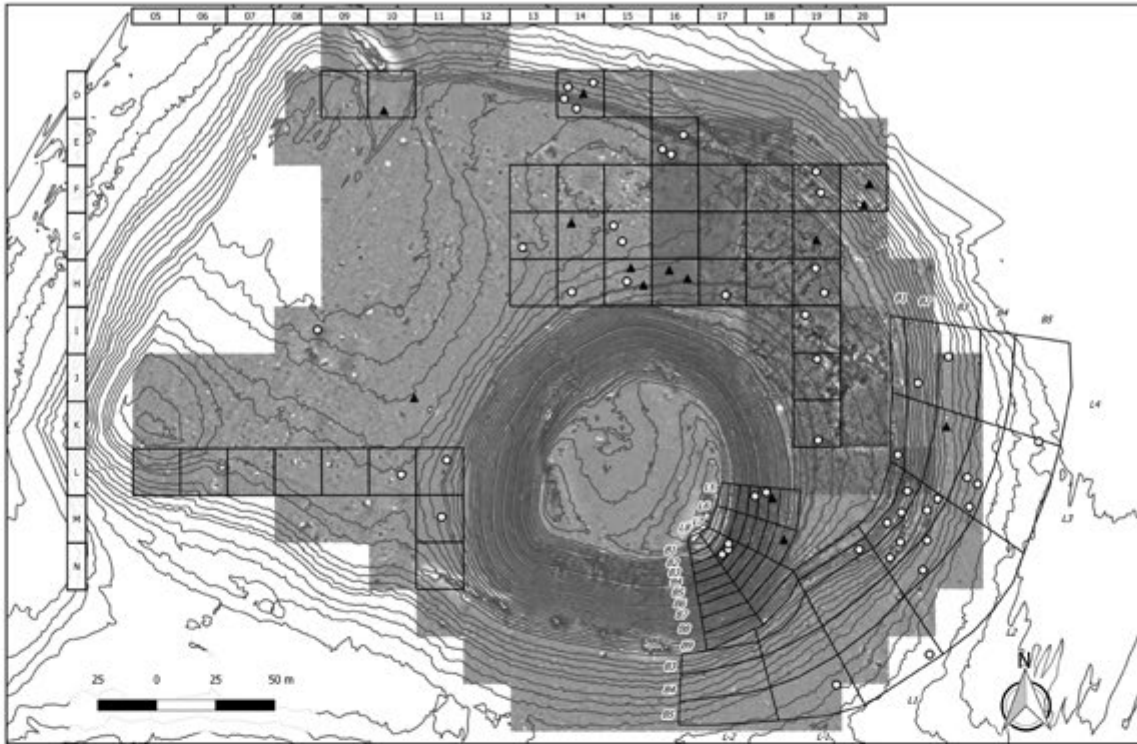
Red Slip and Orange Slip
(generic sherds)

Fig. 79 – Uşaklı Höyük, scatter of wares (generic types).



Kitchen ware
(generic sherds)

Fig. 80 – Uşaklı Höyük, scatter of wares (generic types).

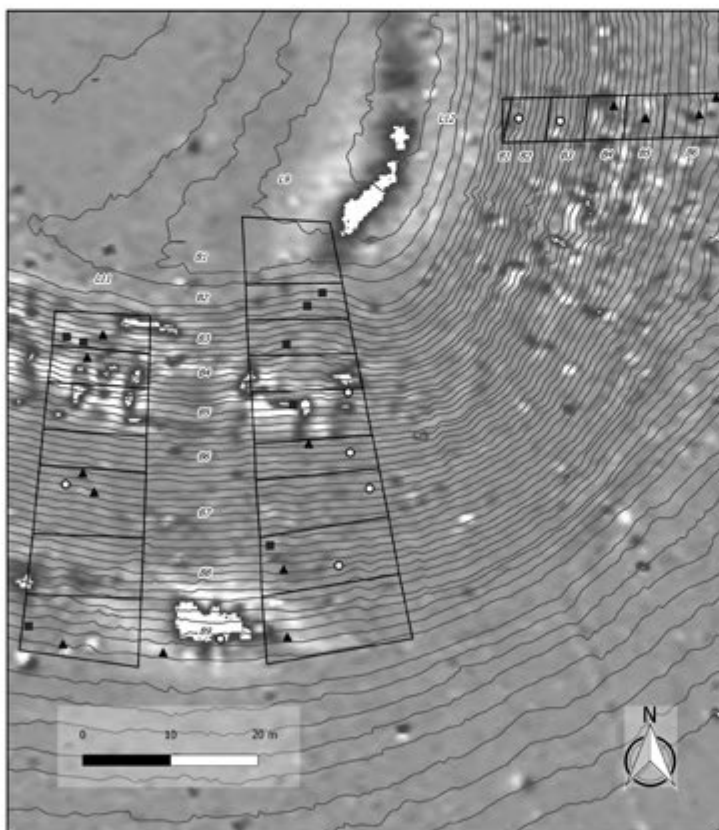
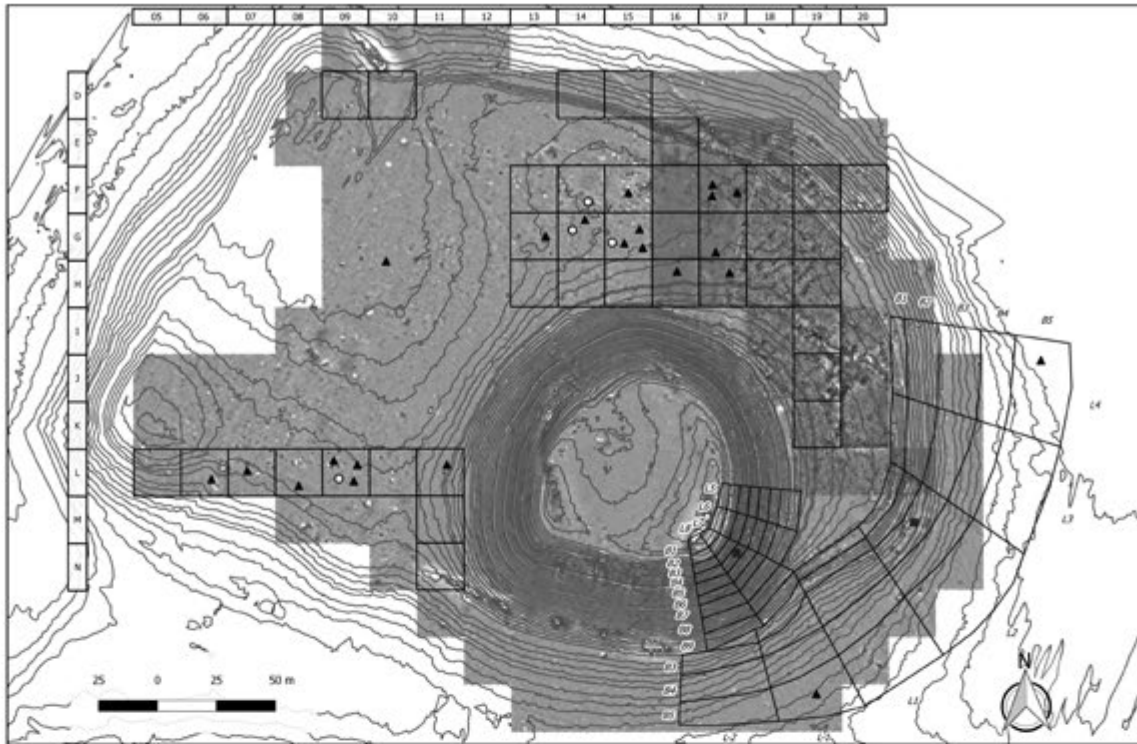


Hand-made sherds

(diagnostic sherds)

- Hand-made sherds
- Hand-made, wheel finished
- ▲ Painted

Fig. 81 – Uşaklı Höyük, scatter of wares (diagnostic types).



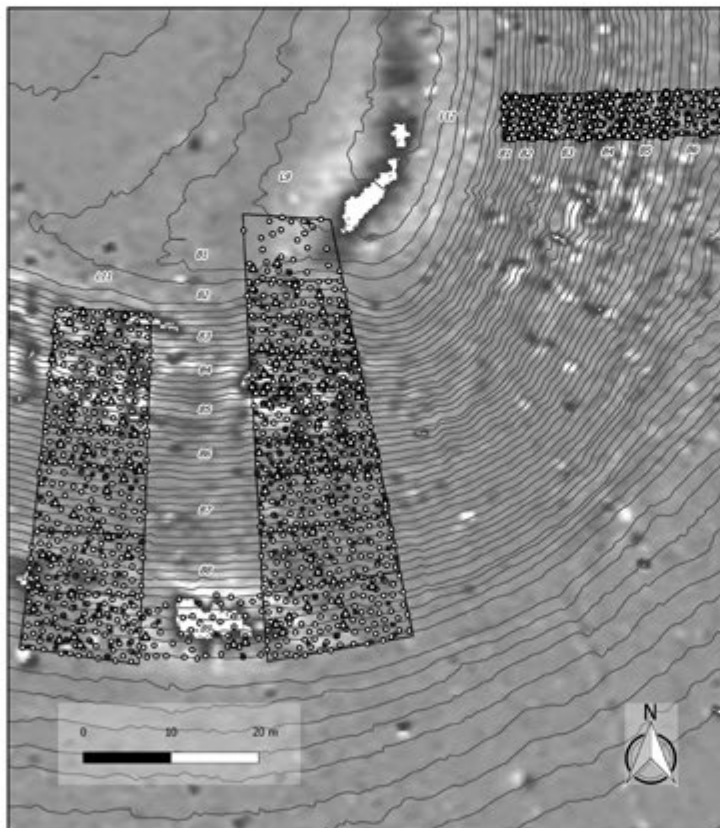
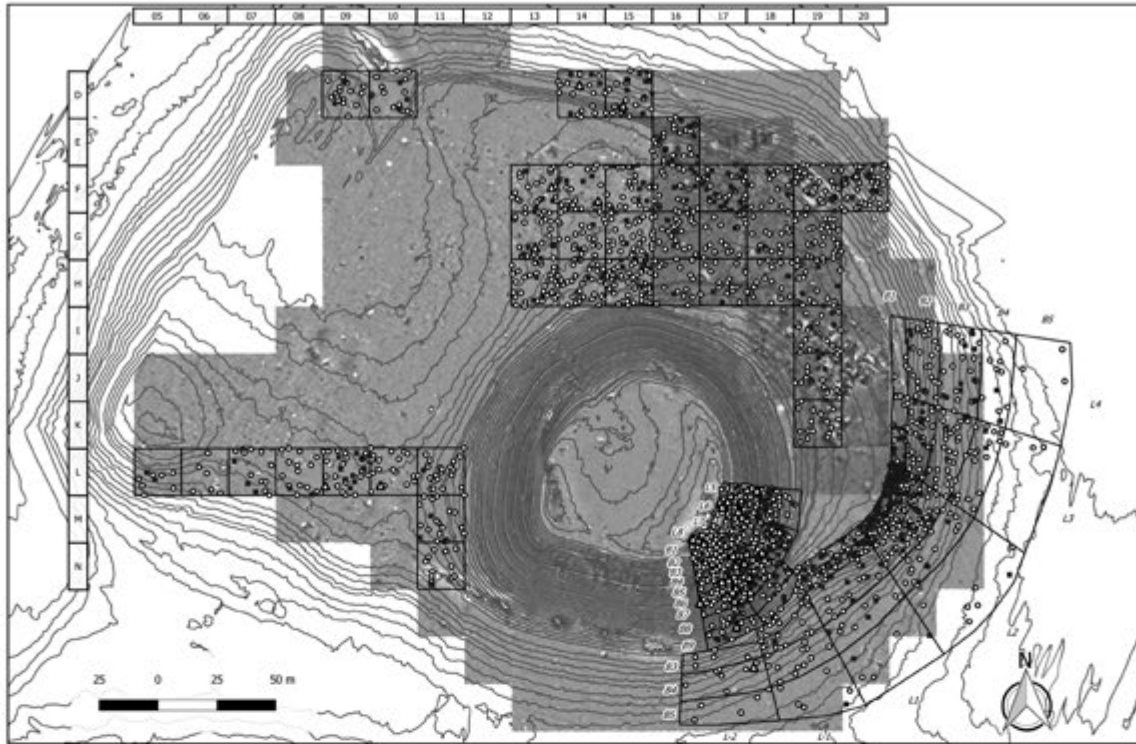
Late Iron Age wares

- Pseudo-brittle
- Reddish Brown
- ▲ Coarse grained

Fig. 82 – Uşaklı Höyük, scatter of wares (diagnostic types).



Fig. 83 – Uşaklı Höyük, density of wares (dekagrams per m²).



DENSITY gm/sq m

- Common ware
- Storage ware
- ▲ Kitchen ware

Fig. 84 – Uşaklı Höyük, density of wares (grams per m²).

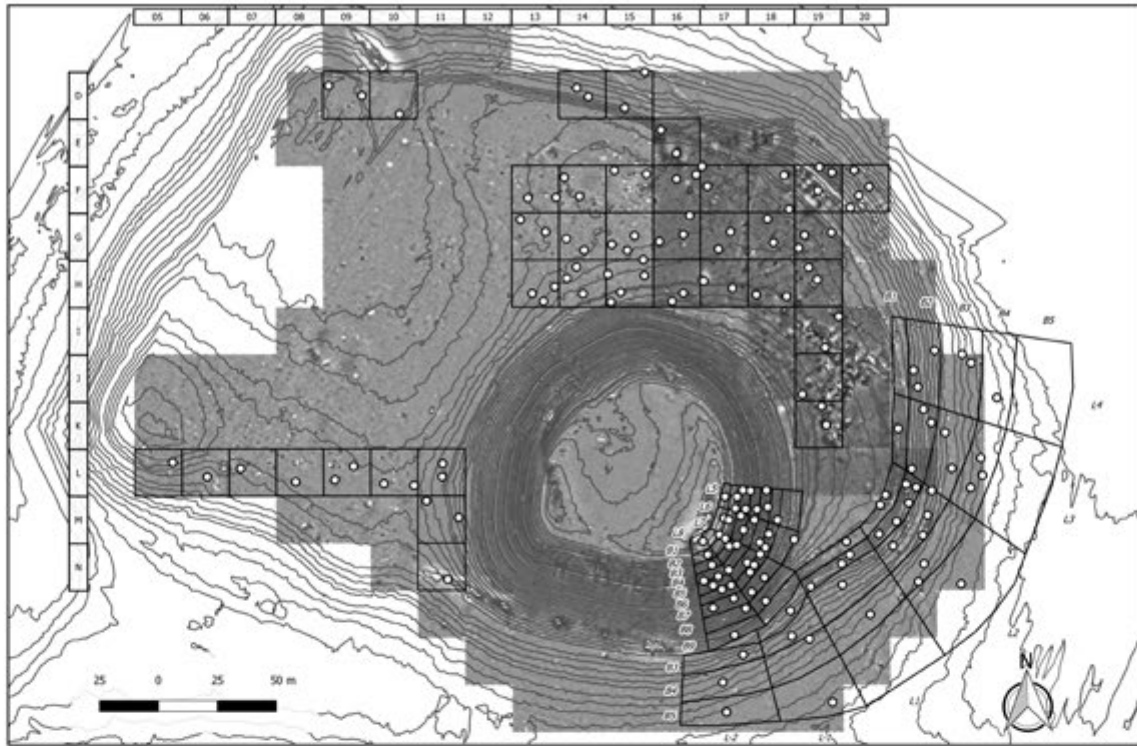
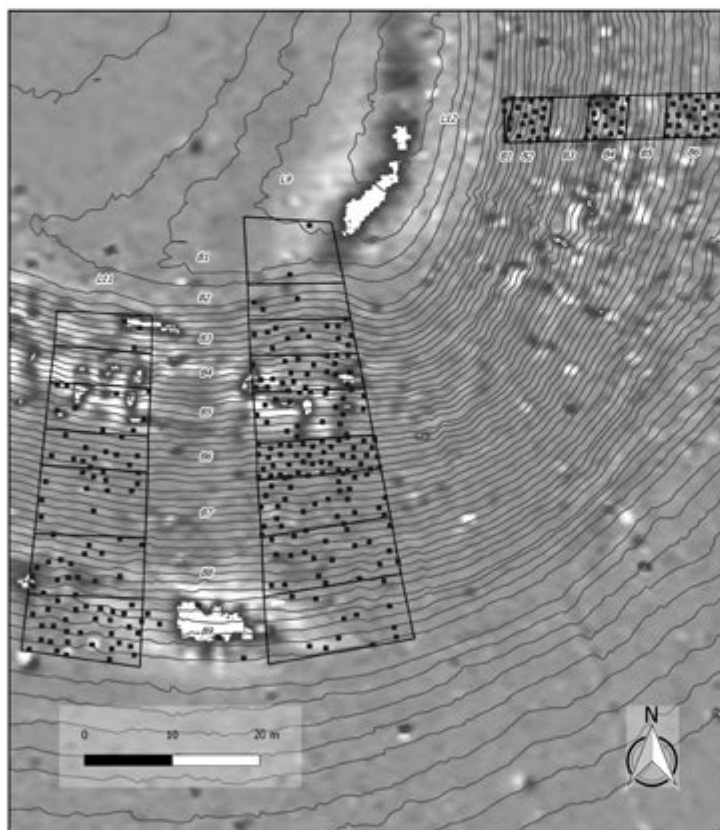
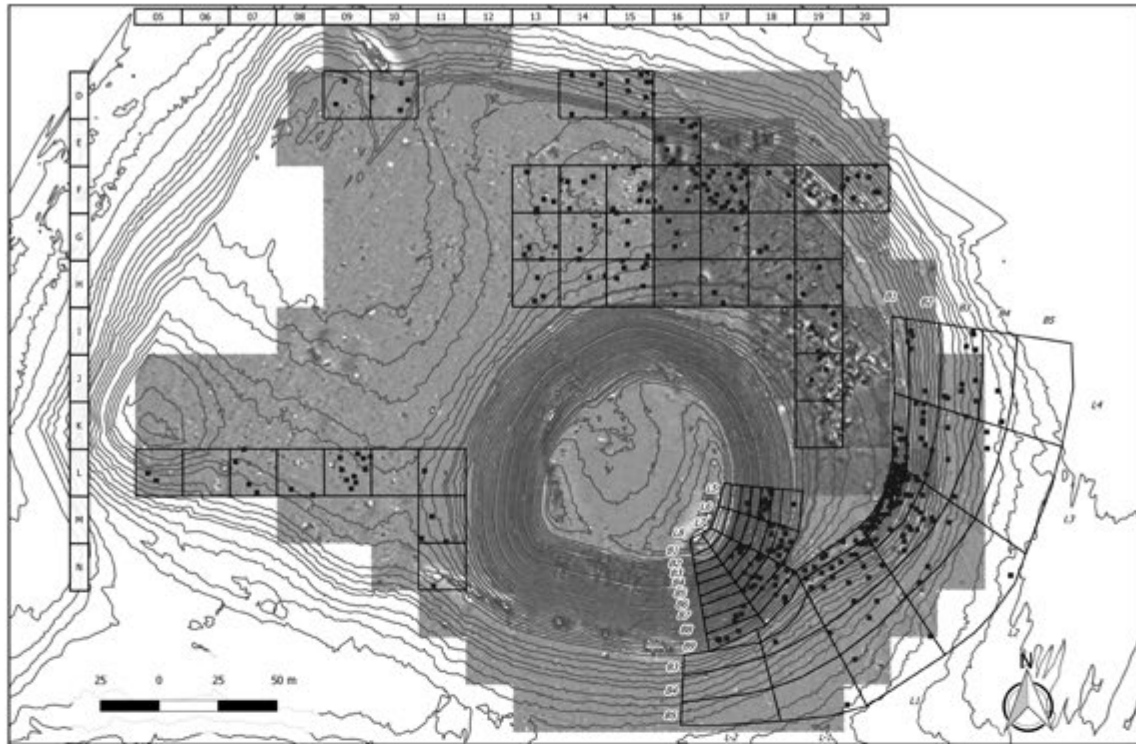


Fig. 85 – Uşaklı Höyük, density of wares (dekagrams per m²).



DENSITY gm/sq m

- Storage ware

Fig. 86 – Uşaklı Höyük, density of wares (grams per m²).

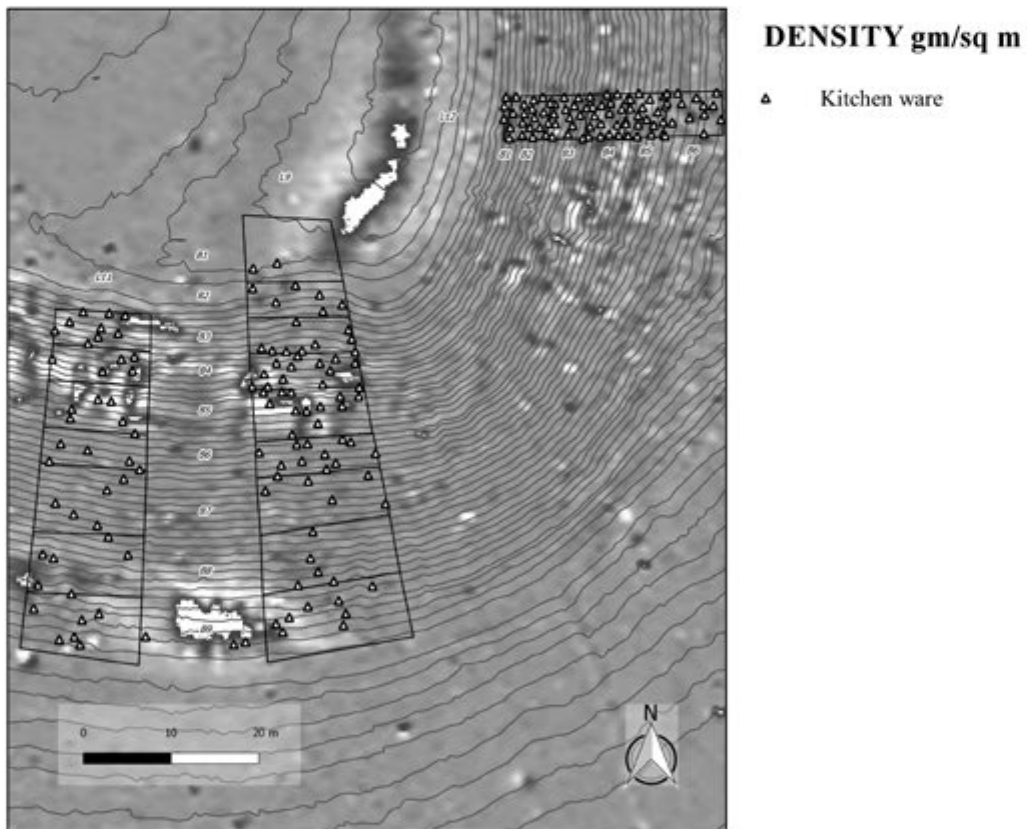
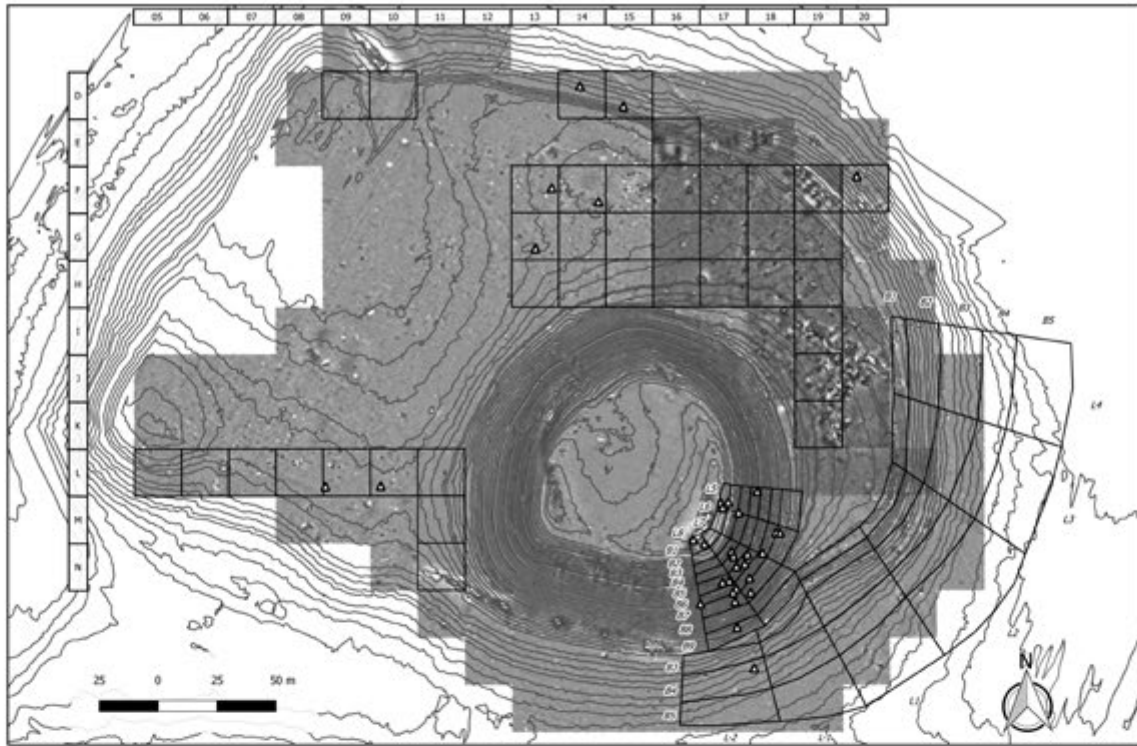


Fig. 87 – Uşaklı Höyük, density of wares (grams per m²).

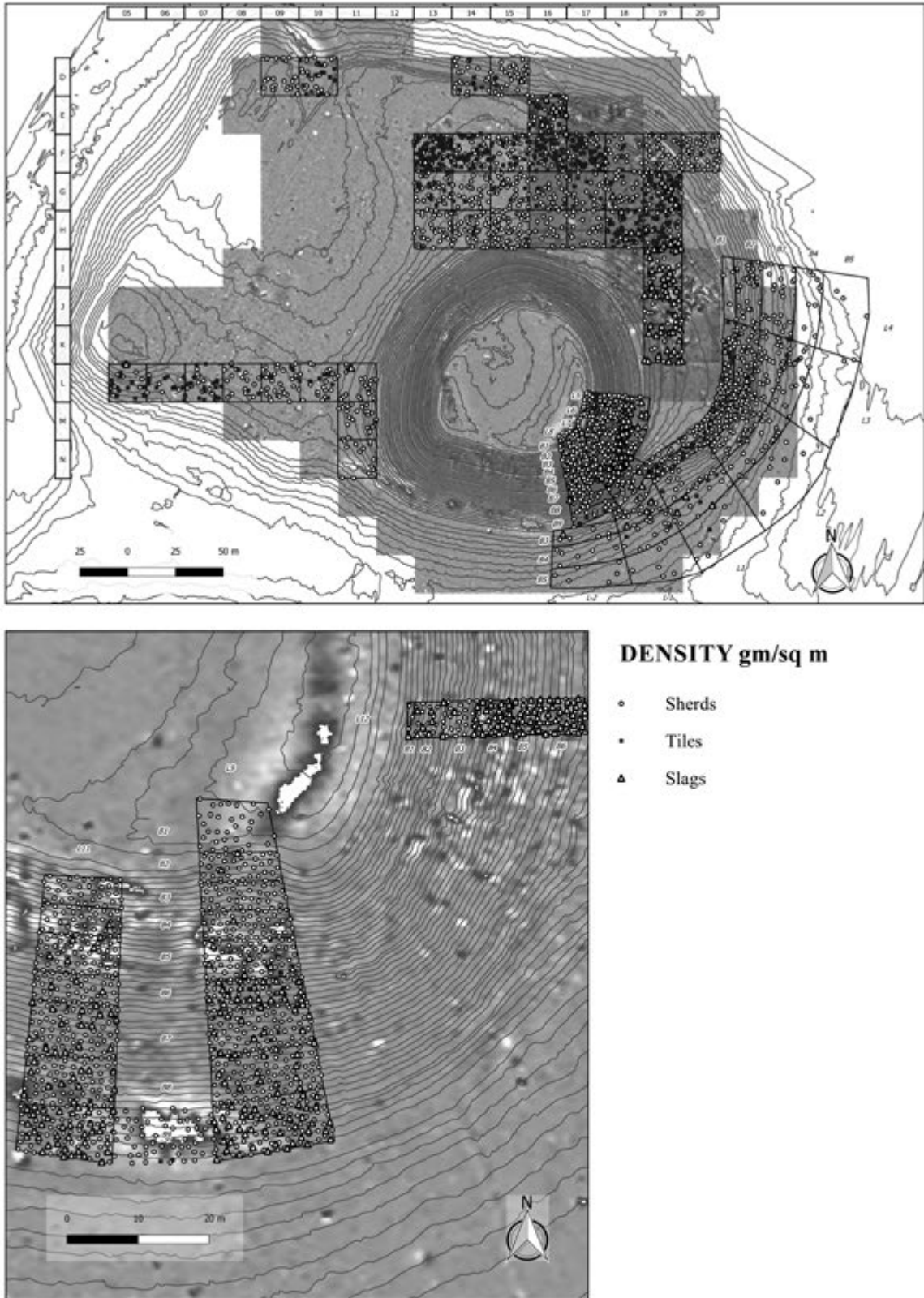


Fig. 88 – Uşaklı Höyük, density of sherds, tiles and slags (grams per m²).

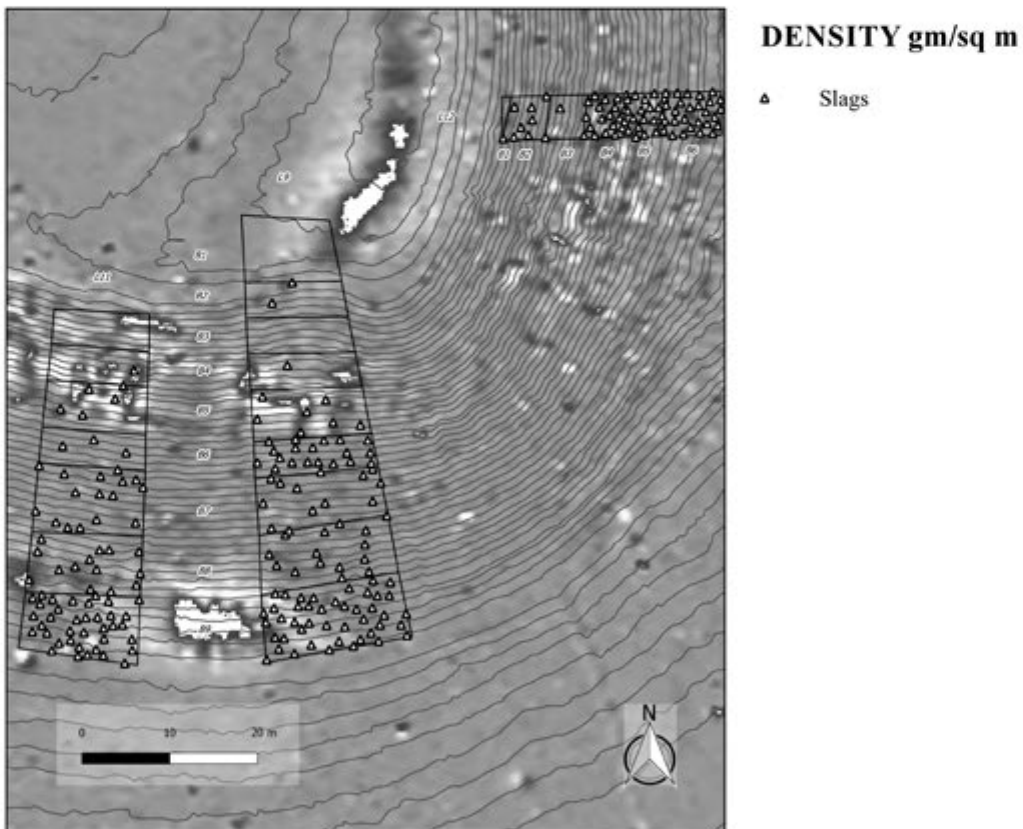
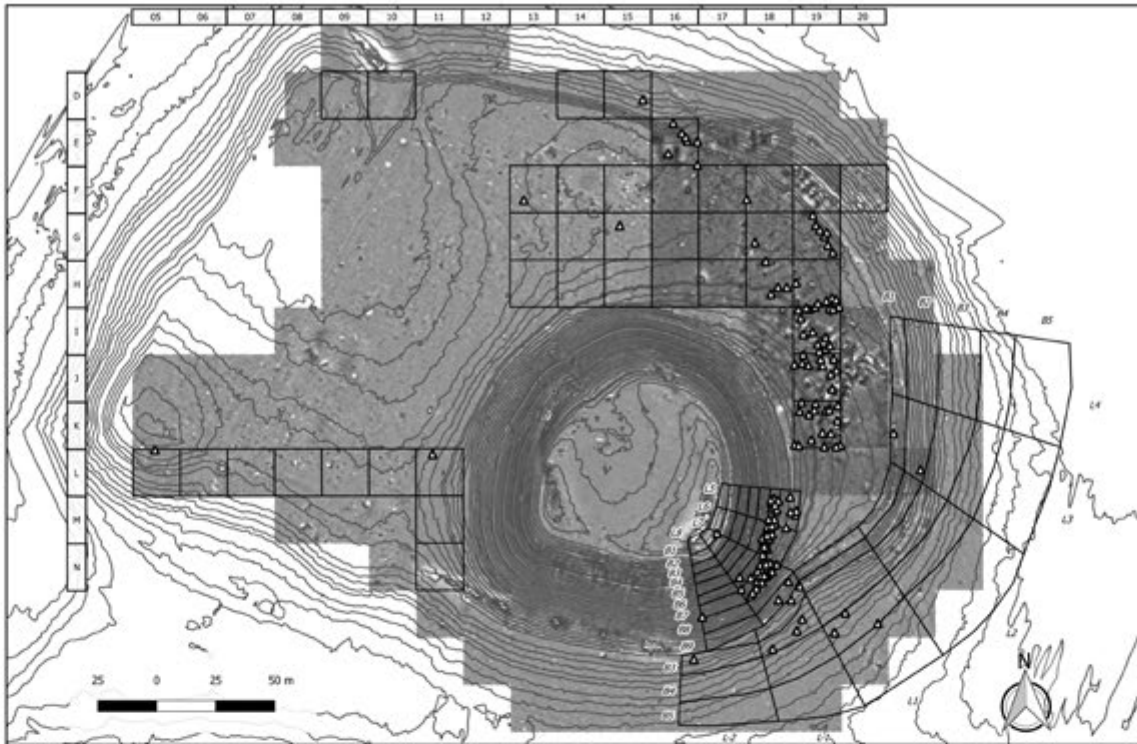
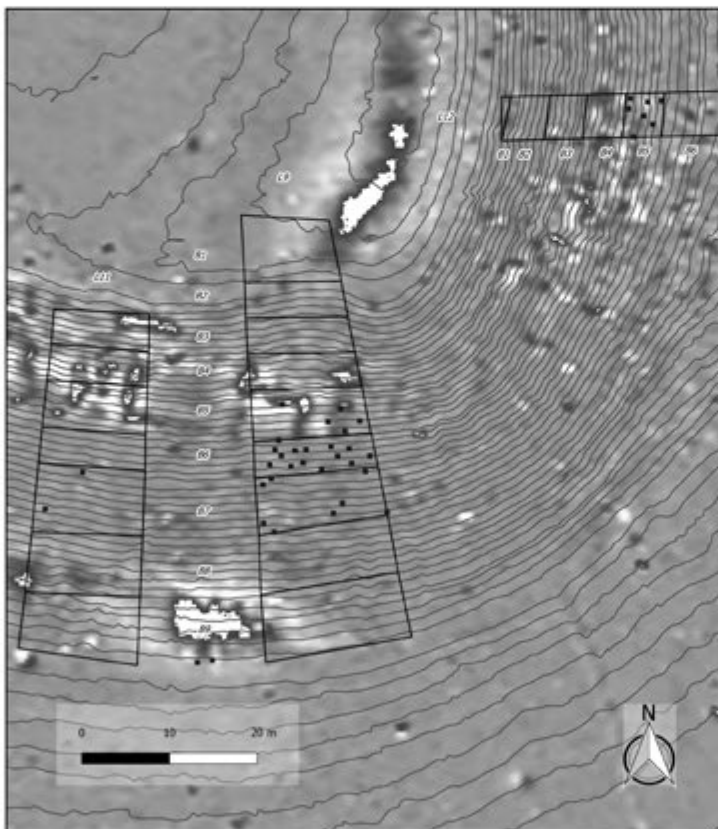
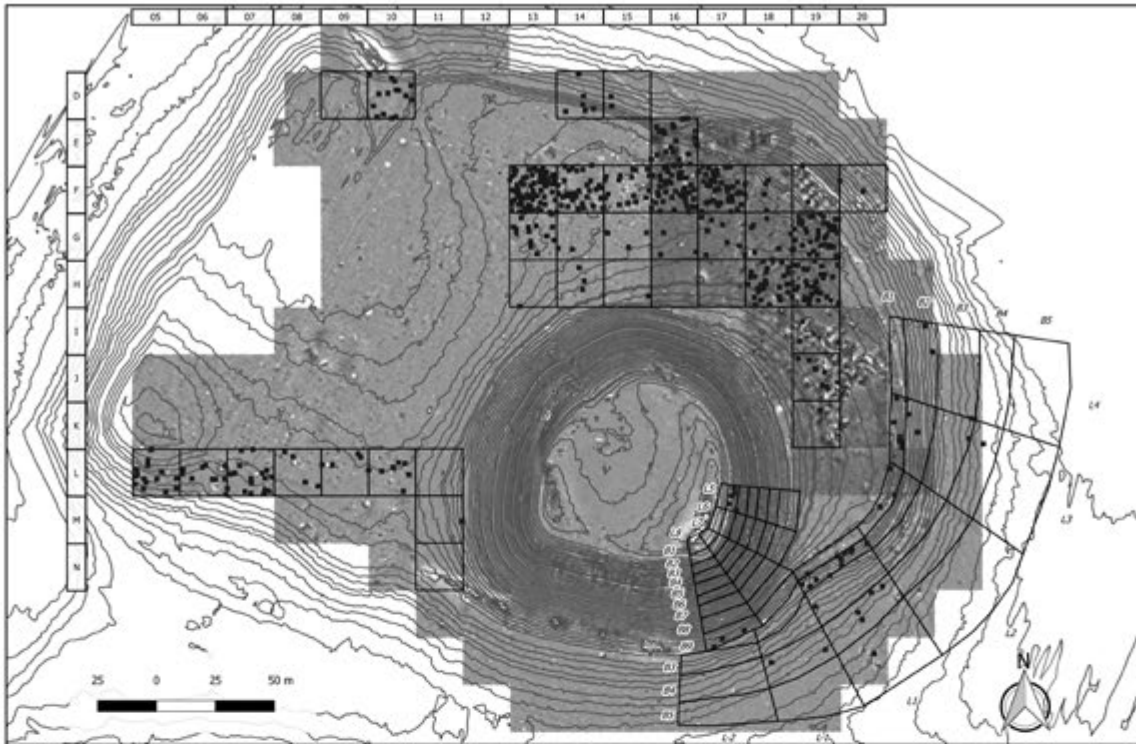


Fig. 89 – Uşaklı Höyük, density of slags (grams per m²).



DENSITY gm/sq m

- Tiles

Fig. 90 – Uşaklı Höyük, density of tiles (grams per m²).

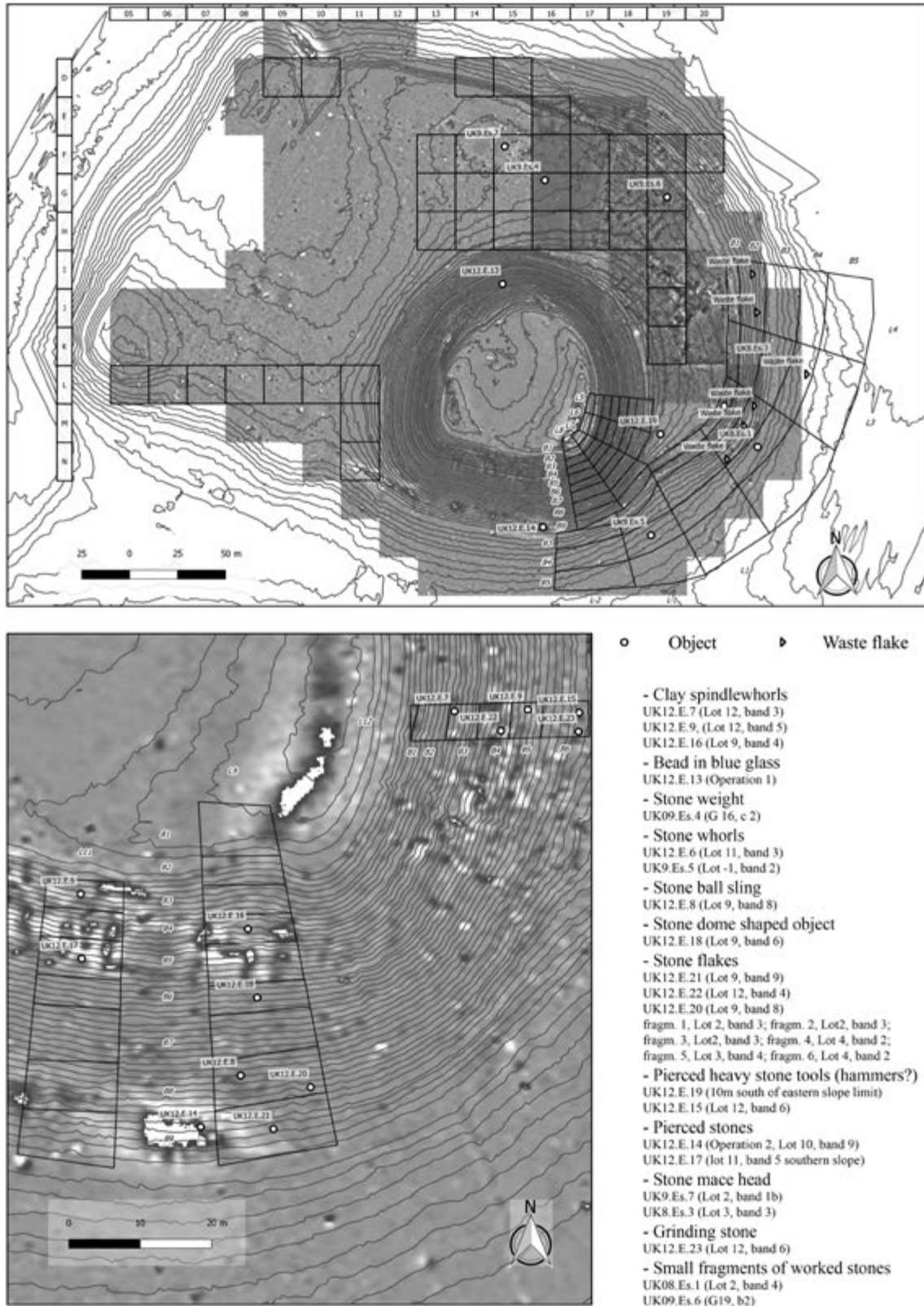


Fig. 91 – Uşaklı Höyük, scatter of objects.

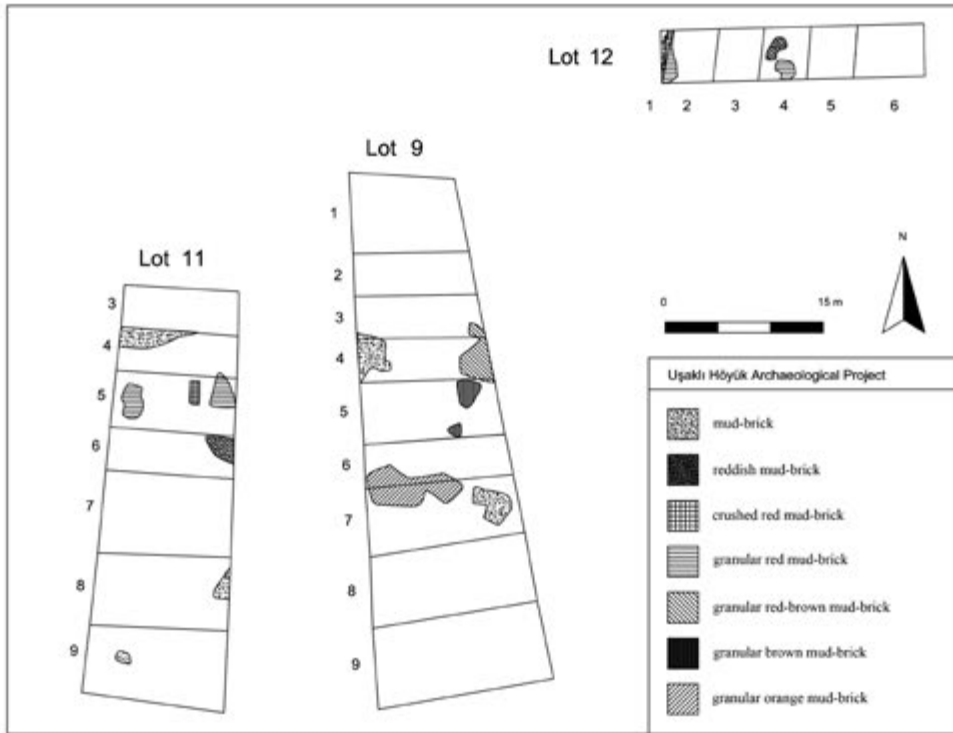


Fig. 92 – Features visible on the surface after scraping (mud-bricks, alignments, patches of different kind of soils; X indicate tablets find spots).

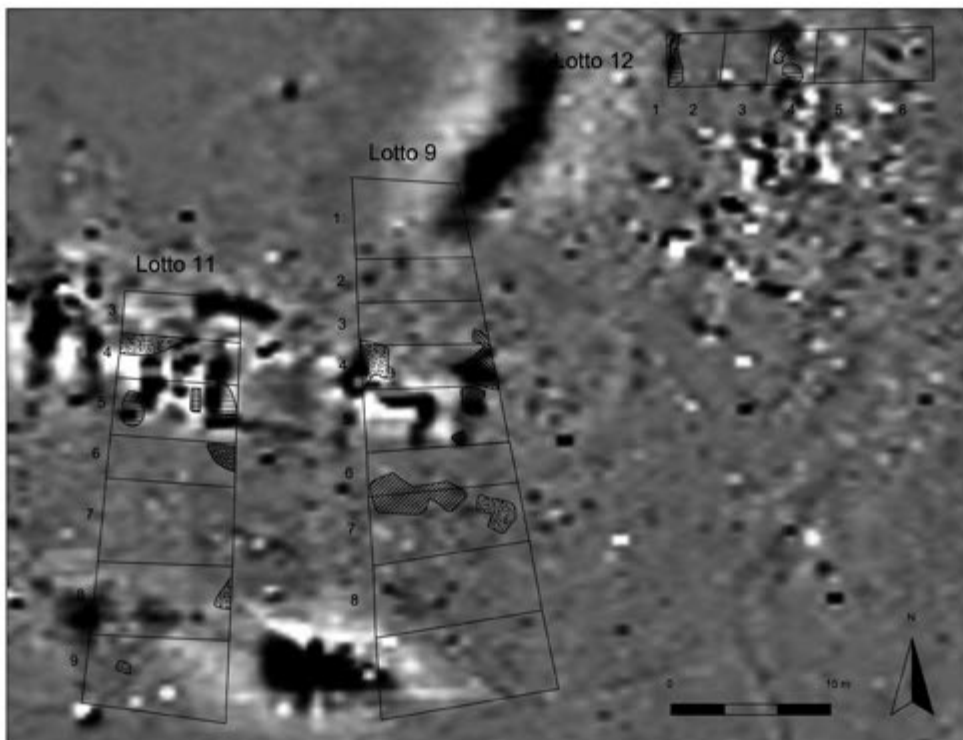


Fig. 93 – Superficial features overlapped to the geomagnetic anomalies.

