

# Mal'cev classes of left quasigroups and quandles

Marco Bonatto and Stefano Fioravanti

**Abstract.** In this paper we investigate some Mal'cev classes of varieties of left quasigroups. We prove that the weakest non-trivial Mal'cev condition for a variety of left quasigroups is having a Mal'cev term and that every congruence meet-semidistributive variety of left quasigroups is congruence arithmetic. Then we specialize to the setting of quandles for which we prove that the congruence distributive varieties are those which have no non-trivial finite models.

## 1. Introduction

Starting from Mal'cev's description of congruence permutability as in [18], the problem of characterizing properties of classes of varieties as *Mal'cev conditions* has led to several results. Mal'cev conditions turned out to be extremely useful, for instance to capture lattice theoretical properties of the congruence lattices of the algebras of classes of variety. In [24] A. Pixley found a strong Mal'cev condition defining the class of varieties with distributive and permuting congruences. In [15] B. Jónsson shows a Mal'cev condition characterizing congruence distributivity, in [10] A. Day shows a Mal'cev condition characterizing the class of varieties with modular congruence lattices.

These results are examples of a more general theorem obtained independently by Pixley [25] and R. Wille [28] that can be considered as a foundational result in the field. They proved that if  $p \leq q$  is a lattice identity, then the class of varieties whose congruence lattices satisfy  $p \leq q$  is the intersection of countably many Mal'cev classes. [25] and [28] include an algorithm to generate Mal'cev conditions associated with congruence identities.

Furthermore, the class of varieties satisfying a non-trivial idempotent Mal'cev condition (i.e. any idempotent Mal'cev condition which is not satisfied by any projection algebra) is known to be a Mal'cev class [27]. This class of varieties was characterized by the existence of a *Taylor* term, namely an idempotent  $n$ -ary term  $t$  that for every coordinate  $i \leq n$  satisfies an identity as

$$t(x_1, \dots, x_n) \approx t(y_1, \dots, y_n)$$

where  $x_1, \dots, x_n, y_1, \dots, y_n \in \{x, y\}$ ,  $x_i = x$  and  $y_i = y$ .

Recently this class of varieties was proven to be a strong Mal'cev class [22], i.e. there exists the weakest strong idempotent Mal'cev condition.

A variety  $\mathcal{V}$  is *meet-semidistributive* if the implication

$$\alpha \wedge \beta = \alpha \wedge \gamma \implies \alpha \wedge \beta = \alpha \wedge (\beta \vee \gamma),$$

holds for every triple of congruences of any algebra in  $\mathcal{V}$ . It is still unknown if the class of meet-semidistributivity varieties is defined by a strong Mal'cev condition, nevertheless it can be characterized in several different ways [23]. On the other hand, we are going to use the characterization of meet-semidistributive varieties in terms of *commutator of congruences* as defined in [11].

**Theorem 1.1.** [17, Theorem 8.1 items (1), (3), (4)]

Let  $\mathcal{V}$  be a variety. The following are equivalent:

- (i)  $\mathcal{V}$  is a congruence meet-semidistributive variety.
- (ii) No member of  $\mathcal{V}$  has a non-trivial abelian congruence.
- (iii)  $[\alpha, \beta] = \alpha \wedge \beta$  for every  $\alpha, \beta \in \text{Con}(A)$  and every  $A \in \mathcal{V}$ .

Let  $A$  be an algebra, let  $\alpha \in \text{Con}(A)$ , and let  $a \in A$ . We denote by  $[a]_\alpha$  the congruence class of  $a$  in  $\alpha$ . The algebra  $A$  is said to be:

- (i) *coherent* if every subalgebra of  $A$  which contains a block of a congruence  $\alpha \in \text{Con}(A)$  is a union of blocks of  $\alpha$ .
- (ii) *Congruence regular* if whenever  $[a]_\alpha = [a]_\beta$  for some  $a \in A$  and  $\alpha, \beta$  in  $\text{Con}(A)$  then  $\alpha = \beta$ .
- (iii) *Congruence uniform* if the blocks of every congruence  $\alpha \in \text{Con}(A)$  have all the same cardinality.

A variety  $\mathcal{V}$  is *coherent* (resp. *congruence uniform*, *congruence regular*) if all the algebras in  $\mathcal{V}$  are coherent (resp. congruence uniform, congruence regular). Because for varieties regularity is equivalent to the condition that no non-zero congruence has a singleton congruence class, every congruence uniform variety is congruence regular. Congruence regularity and coherency are weak Mal'cev classes (see [9] and [12]). On the other hand, it is known that congruence uniformity is not defined by a Mal'cev condition [26].

Some of the most studied Mal'cev classes of varieties are displayed in Figure 1. We refer the reader to [2] for further informations about such classes and to [3] for a more exhaustive poset of Mal'cev classes.

The main goal of this paper is to investigate Mal'cev conditions for racks and quandles. In particular, this paper is concerned with certain Mal'cev classes of varieties, namely, the varieties having a Taylor term, a Mal'cev term and congruence meet semi-distributive varieties.

Left quasigroups are rather combinatorial objects, nevertheless Mal'cev classes of varieties of left quasigroups behave in a pretty rigid way. A characterization of Mal'cev varieties of left quasigroups is provided in Theorem 3.2: they are the varieties for which every left quasigroup is connected, (a left quasigroup is connected

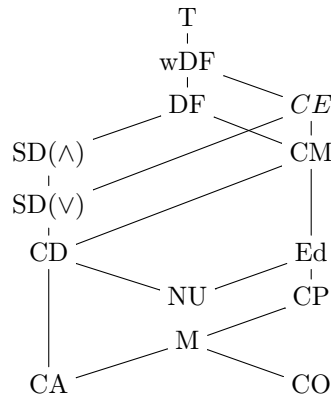

Figure 1: Mal'cev classes: T = Taylor term, wDF = weak difference term, CE = non trivial congruence equation, DF = difference term, CM = congruence modularity, Ed = edge term, CP = congruence permutability, M = Mal'cev term, CO = congruence coherency, SD( $\wedge$ ) = meet semidistributivity, SD( $\vee$ ) = join semidistributivity, CD = congruence distributivity, NU =  $CD \cap Ed$  = near unanimity term, CA =  $CD \cap M$  = congruence arithmeticity.

if the action of its left multiplication group is transitive). Moreover, we show that several Mal'cev conditions are equivalent for varieties of left quasigroups. In particular, all the classes in the interval between the class of Taylor varieties and the class of coherent varieties in Figure 1 collapse into the strong Mal'cev class of varieties with a Mal'cev term. Moreover, we prove that the weakest non-trivial (not necessarily idempotent) Mal'cev condition for left quasigroups is having a Mal'cev term, and all such varieties are congruence uniform. In Corollary 3.3 we characterize finite Mal'cev idempotent left quasigroups as the superconnected idempotent left quasigroups (i.e. left quasigroups such that all the subalgebras are connected) using a general result given in [1].

In Theorem 3.5 we show that a congruence meet-semidistributive variety of left quasigroups is congruence arithmetic.

As a consequence of our two main theorems, the poset of Mal'cev classes of left quasigroups in Figure 1 turns into the one in Figure 2.

$$\begin{array}{c}
 T = CO = M \\
 | \\
 NU = SD(\wedge) = CA
 \end{array}$$

Figure 2: Mal'cev classes of varieties of left quasigroups.

Then we turn our attention to quandles, i.e. idempotent left distributive left quasigroups. Quandles are of interest since they provide knot invariants [16, 19]. The class of quandles used for such topological applications is the class of con-

nected quandles. According to the characterization of Mal'cev varieties of left quasigroups, connectedness is actually a relevant property also algebraically. Some of the contents of the paper are formulated for *semimedial* left quasigroups, a class that contain racks and medial left quasigroups [5].

A characterization of distributive varieties of semimedial left quasigroup is given by the properties of the displacement group in Theorem 4.3 where we take advantage of the adaptation of the commutator theory in the sense of [11] developed first for racks in [8] and then extended to semimedial left quasigroups in [5].

In Theorem 4.9 we prove that a variety of quandles is distributive if and only if it has no finite models, making use of the characterization of strictly simple and simple abelian quandles [4]. We also prove that there is no distributive variety of involutory quandles. The problem of finding an example of non-trivial distributive variety of quandles (resp. left quasigroups) is still open.

Examples of non-trivial Mal'cev varieties of quandles (which members are not just left quasigroup reducts of quasigroups) are provided in Table 1.

**Notation and terminology.** We refer to [2] for basic concepts of universal algebra. Let  $A$  be an algebra and  $t$  be an  $n$ -ary term. Then we say that  $A$  satisfies the identity  $t_1(x_1, \dots, x_n) \approx t_2(x_1, \dots, x_n)$  if  $t_1(a_1, \dots, a_n) = t_2(a_1, \dots, a_n)$  for every  $a_i \in A$ .

We denote by  $\mathbf{H}(A)$ ,  $\mathbf{S}(A)$  and  $\mathbf{P}(A)$  respectively the set of homomorphic images, subalgebras and powers of the algebra  $A$  and  $\mathcal{V}(\mathcal{K})$  denotes the variety generated by the class of algebras  $\mathcal{K}$ . We denote by  $\text{Con}(A)$  the congruence lattice of  $A$ , the block of  $a \in A$  with respect to a congruence  $\alpha$  is denoted by  $[a]_\alpha$  (or simply by  $[a]$ ) and the factor algebra by  $A/\alpha$ . We denote by  $1_A = A \times A$  and  $0_A = \{(a, a) : a \in A\}$  respectively the top and bottom element in the congruence lattice of  $A$ .

Through all the paper, concrete examples of left quasigroups are computed using the software Mace4 [20] and examples of quandles are taken from the library of connected quandles of GAP [13].

## 2. Left quasigroups

A left quasigroup is a binary algebraic structure  $(Q, *, \setminus)$  such that the following identities hold:

$$x * (x \setminus y) \approx y \approx x \setminus (x * y).$$

Hence, a left quasigroup is a set  $Q$  endowed with a binary operation  $*$  such that the mapping  $L_x: y \mapsto x * y$  is a bijection of  $Q$  for every  $x \in Q$ . The right multiplication mappings  $R_x: y \mapsto y * x$  need not to be bijections. Clearly the left division is defined by  $x \setminus y = L_x^{-1}(y)$ , so we usually denote left quasigroups just as a pair  $(Q, *)$ . Nevertheless, if  $(Q, *)$  is a left quasigroup and  $(R, *)$  is a binary algebraic structure and  $f: Q \rightarrow R$  is a homomorphism with respect to  $*$ , the image

of  $f$  is not necessarily a left quasigroup. We define the *left multiplication group of  $Q$*  as  $\text{LMlt}(Q) = \langle L_a, a \in Q \rangle$ .

Let  $\alpha$  be a congruence of a left quasigroup  $Q$ . The map

$$\text{LMlt}(Q) \longrightarrow \text{LMlt}(Q/\alpha), \quad L_a \mapsto L_{[a]}$$

can be extended to a surjective morphism of groups with kernel denoted by  $\text{LMlt}^\alpha$ . The *displacement group relative to  $\alpha$* , denoted by  $\text{Dis}_\alpha$ , is the normal closure in  $\text{LMlt}(Q)$  of  $\{L_a L_b^{-1} : a \alpha b\}$ . In particular, we denote by  $\text{Dis}(Q)$  the displacement group relative to  $1_Q$  and we simply call it the *displacement group of  $Q$* . The maps defined above clearly restrict and corestrict to the displacement groups of  $Q$  and  $Q/\alpha$  and we denote by  $\text{Dis}^\alpha$  the intersection between  $\text{LMlt}^\alpha$  and  $\text{Dis}(Q)$ .

**Lemma 2.1.** *Let  $\mathcal{K}$  be a class of left quasigroups and  $Q \in \mathcal{V}(\mathcal{K})$ . Then:*

- (i)  $\text{Dis}(Q) \in \mathcal{V}(\{\text{Dis}(R) : R \in \mathcal{K}\})$ .
- (ii)  $\text{LMlt}(Q) \in \mathcal{V}(\{\text{LMlt}(R) : R \in \mathcal{K}\})$ .

*Proof.* (i). Let  $\{Q_i : i \in I\} \subseteq \mathcal{K}$ . The group  $\text{Dis}(Q_i/\alpha) \in \mathbf{H}(\text{Dis}(Q_i))$ . Let  $S$  be a subalgebra of  $Q_i$  and  $H = \langle L_a, a \in S \rangle$ . Then

$$\text{Dis}(S) \cong \langle h L_a L_b^{-1} h^{-1} |_{S}, a, b \in S, h \in H \rangle \in \mathbf{HS}(\text{Dis}(Q_i)).$$

Let  $Q = \prod_{i \in I} Q_i$  and  $\alpha_i$  the kernel of the canonical homomorphism onto  $Q_i$ . Then  $\bigcap_{i \in I} \text{Dis}^{\alpha_i} = 1$  and so we have a canonical embedding

$$\text{Dis}(Q) \hookrightarrow \prod_{i \in I} \text{Dis}(Q)/\text{Dis}^{\alpha_i} = \prod_{i \in I} \text{Dis}(Q_i),$$

i.e.  $\text{Dis}(Q) \in \mathbf{SP}(\{\text{Dis}(Q_i) : i \in I\})$ . The same argument can be used for (ii).  $\square$

In [5, Section 1] we introduced the lattice of *admissible subgroups* of a left quasigroup  $Q$ . Given  $N \leq \text{LMlt}(Q)$  we have two equivalence relations on the underlying set of the left quasigroup  $Q$ :

- (i) the orbit decomposition with respect to the action of  $N$ , denoted by  $\mathcal{O}_N$ .
- (ii) The equivalence  $\text{con}_N$  defined as

$$a \text{con}_N b \text{ if and only if } L_a L_b^{-1} \in N.$$

The assignments  $\alpha \mapsto \text{Dis}_\alpha$  (resp.  $\text{Dis}^\alpha$ ) and  $N \mapsto \text{con}_N$  (resp.  $\mathcal{O}_N$ ) are monotone and  $\text{Dis}_\alpha \leq \text{Dis}^\alpha$  (see the characterization of congruences in terms of the properties of subgroups provided in [5, Lemma 1.5]), whereas in general no containment between the equivalences  $\text{con}_N$  and  $\mathcal{O}_N$  holds.

We define the lattice of admissible subgroups as

$$\text{Norm}(Q) = \{N \trianglelefteq \text{LMlt}(Q) : \mathcal{O}_N \subseteq \text{con}_N\}.$$

In particular,  $\mathcal{O}_N$  is a congruence of  $Q$  whenever  $N$  is admissible and  $\text{Dis}_\alpha, \text{Dis}^\alpha \in \text{Norm}(Q)$  for every congruence  $\alpha$ . The assignments  $N \mapsto \mathcal{O}_N$  and  $\alpha \mapsto \text{Dis}^\alpha$  provide a monotone Galois connection between  $\text{Norm}(Q)$  and the congruence lattice of  $Q$  [5, Theorem 1.10].

The *Cayley kernel* of a left quasigroup  $Q$  is the equivalence relation  $\lambda_Q$  defined by

$$a \lambda_Q b \text{ if and only if } L_a = L_b.$$

Such a relation is not a congruence in general. We say that:

- (i)  $Q$  is a *Cayley* left quasigroup if  $\lambda_Q$  is a congruence. A class of left quasigroups is *Cayley* if all its members are *Cayley* left quasigroups.
- (ii)  $Q$  is *faithful* if  $\lambda_Q = 0_Q$  and  $Q$  is *superfaithful* if all the subalgebras of  $Q$  are faithful.
- (iii)  $Q$  is *permutation* if  $\lambda_Q = 1_Q$ , i.e. there exists  $f \in \text{Sym}(Q)$  such that  $a * b = f(b)$  for every  $a, b \in Q$ . If  $f = 1$  we say that  $Q$  is a *projection* left quasigroup (we denote by  $\mathcal{P}_n$  the projection left quasigroup of size  $n$ ). Note that, permutation left quasigroups are unary algebras and that projection left quasigroups are also called right zero semigroups.

According to [7, Theorem 5.3], the *strongly abelian* congruences of left quasigroups (in the sense of [21]) are exactly those below the Cayley kernel. Equivalently, if  $\alpha$  is a congruence of a left quasigroup  $Q$ , then  $\alpha \leq \lambda_Q$  if and only if  $\text{Dis}_\alpha = 1$ .

A left quasigroup  $Q$  is *connected* if its left multiplication group is transitive on  $Q$ . We say that  $Q$  is *superconnected* if all the subalgebras of  $Q$  are connected. We investigated superconnected left quasigroups in [6].

**Proposition 2.2.** [6, Corollary 1.6] *A left quasigroup  $Q$  is superconnected if and only if  $\mathcal{P}_2 \notin \mathbf{HS}(Q)$ .*

The property of being (super)connected is also reflected by the properties of congruences.

**Lemma 2.3.** *Connected left quasigroups are congruence uniform and congruence regular.*

*Proof.* Let  $Q$  be a connected left quasigroup and assume that  $[a]_\alpha = [a]_\beta$  for some  $a \in Q$ . For every  $b \in Q$  there exists  $h \in \text{LMlt}(Q)$  with  $b = h(a)$ . The blocks of congruences are blocks with respect to the action of  $\text{LMlt}(Q)$ . Then

$$[b]_\alpha = [h(a)]_\alpha = h([a]_\alpha) = h([a]_\beta) = [h(a)]_\beta = [b]_\beta,$$

and so  $\alpha = \beta$ . In particular, the mapping  $h$  is a bijection between  $[a]_\alpha$  and  $[b]_\alpha$  for every  $\alpha \in \text{Con}(Q)$ .  $\square$

**Lemma 2.4.** *Superconnected left quasigroups are coherent.*

*Proof.* Let  $Q$  be a superconnected left quasigroup,  $M$  be a subalgebra of  $Q$  and  $\alpha \in \text{Con}(Q)$  with  $[a]_\alpha \subseteq M$  for some  $a \in M$ . For every  $b \in M$  there exists  $h \in \text{LMlt}(M)$  such that  $b = h(a)$ . The blocks of  $\alpha$  are blocks with respect to the action of  $\text{LMlt}(Q)$  and  $M$  is a subalgebra, then  $h([a]_\alpha) = [b]_\alpha \subseteq M$ . Therefore,  $M = \bigcup_{b \in M} [b]_\alpha$ .  $\square$

A *quasigroup* is a binary algebra  $(Q, *, \backslash, /)$  such that  $(Q, *, \backslash)$  is a left quasigroup (the *left quasigroup reduct* of  $Q$ ) and  $(Q, *, /)$  is a right quasigroup. The left quasigroups obtained as reducts of quasigroups are called *latin* (note that congruence and subalgebras of a quasigroup and its left quasigroup reduct might be different due to the different signature considered for the two structures). Latin left quasigroups are superfaithful and connected.

The *squaring mapping* for a left quasigroup is the map  $\mathfrak{s} : Q \rightarrow Q, a \mapsto a * a$ . We denote the set of *idempotent elements of  $Q$*  by

$$E(Q) = \text{Fix}(\mathfrak{s}) = \{a \in Q : a * a = a\}.$$

We say that:

- (i)  $Q$  is *idempotent* if  $Q = E(Q)$ , i.e. the identity  $x * x \approx x$  holds in  $Q$ .
- (ii)  $Q$  is *2-divisible* if  $\mathfrak{s}$  is a bijection.
- (iii)  $Q$  is  *$n$ -multipotent* if  $|\mathfrak{s}^n(Q)| = 1$  (here  $\mathfrak{s}^n = \mathfrak{s} \circ \mathfrak{s}^{n-1}$  denotes the usual composition of maps). If  $n = 1$  we say that  $Q$  is *unipotent*.

### 3. Mal'cev classes of left quasigroups

In this section we turn our attention to Mal'cev classes of left quasigroups. According to [17, Theorem 3.13] a variety with a Taylor term does not contain any strongly abelian congruence, so in particular Taylor varieties of left quasigroup do not contain permutation left quasigroups (if  $Q$  is permutation, then  $1_Q = \lambda_Q$  is strongly abelian).

**Proposition 3.1.** *Let  $\mathcal{V}$  be a Taylor variety of left quasigroups. Then  $\text{Dis}(Q)$  is transitive on  $Q$  for every  $Q \in \mathcal{V}$ .*

*Proof.* Let  $Q \in \mathcal{V}$ . According to [5, Corollary 1.9],  $P = Q/\mathcal{O}_{\text{Dis}(Q)}$  is a permutation left quasigroup and so  $P$  is trivial, i.e.  $\text{Dis}(Q)$  is transitive on  $Q$ .  $\square$

For left quasigroups, the interval of Mal'cev classes between the class of Taylor varieties and the class of coherent varieties collapses into the class of varieties with a Mal'cev term.

**Theorem 3.2.** *Let  $\mathcal{V}$  be a variety of left quasigroups. The following are equivalent:*

- (i)  $\mathcal{V}$  has a Mal'cev term.
- (ii)  $\mathcal{V}$  has a Taylor term.
- (iii)  $\mathcal{V}$  satisfies a non-trivial idempotent Mal'cev condition.

(iv)  $\mathcal{V}$  satisfies a non-trivial Mal'cev condition.

(v)  $\mathcal{P}_2 \notin \mathcal{V}$ .

(vi) Every algebra in  $\mathcal{V}$  is superconnected.

(vii)  $\mathcal{V}$  is coherent.

In particular, every Mal'cev variety of left quasigroup is congruence uniform.

*Proof.* The implications (i)  $\Rightarrow$  (ii) and (vii)  $\Rightarrow$  (i) hold in general as represented in Figure 1, (ii)  $\Rightarrow$  (iii)  $\Rightarrow$  (iv)  $\Rightarrow$  (iv) clearly hold.

(v)  $\Rightarrow$  (vi). According to Proposition 2.2, if  $\mathcal{P}_2 \notin \mathcal{V}$  then every left quasigroup in  $\mathcal{V}$  is connected and then superconnected since  $\mathcal{V}$  is closed under taking subalgebras.

(vi)  $\Rightarrow$  (vii). By Lemma 2.4 every superconnected left quasigroup is coherent, i.e.  $\mathcal{V}$  is coherent.

According to Lemma 2.3, connected left quasigroups are congruence uniform, therefore so is any Mal'cev variety of left quasigroup.  $\square$

**Corollary 3.3.** *Let  $Q$  be a finite idempotent left quasigroup. Then  $\mathcal{V}(Q)$  has a Mal'cev term if and only if  $Q$  is superconnected.*

*Proof.* Let  $Q$  be a finite idempotent left quasigroup. According to [1, Theorem 1.1],  $\mathcal{V}(Q)$  has Taylor term if and only if  $\mathcal{P}_2 \notin \mathbf{HS}(Q)$ . Thus,  $\mathcal{V}(Q)$  has Taylor term if and only if  $Q$  is superconnected by Proposition 2.2.  $\square$

**Proposition 3.4.** *Let  $\mathcal{V}$  be a Cayley (resp. idempotent) Mal'cev variety of left quasigroups and  $Q \in \mathcal{V}$ . Then:*

(i) every left quasigroups in  $\mathcal{V}$  is superfaithful.

(ii) The Dis operator is injective and the con operator is surjective and  $\alpha = \text{con}_{\text{Dis}_\alpha} = \text{con}_{\text{Dis}^\alpha}$  for every  $\alpha \in \text{Con}(Q)$ .

*Proof.* (i). Idempotent superconnected left quasigroups are superfaithful according to [6, Lemma 1.9], so the claim follows if  $\mathcal{V}$  is idempotent.

Assume that  $\mathcal{V}$  is a Cayley variety. The Cayley kernel is a strongly abelian congruence for Cayley left quasigroups (see [7, Proposition 5.1]), therefore the left quasigroups in  $\mathcal{V}$  are superfaithful.

(ii). All the left quasigroups in  $\mathcal{V}$  are superfaithful by (i). According to [5, Proposition 1.6] we have that

$$\alpha \leq \text{con}_{\text{Dis}_\alpha} \leq \text{con}_{\text{Dis}^\alpha} = \alpha.$$

and so the operator  $\text{con}_{\text{Dis}}$  is the identity on  $\text{Con}(Q)$ .  $\square$

Let us turn our attention to congruence distributive varieties of left quasigroups. We have already proved that every Taylor variety of left quasigroups is also Mal'cev. Therefore, the left branch of the poset in Figure 1 also collapses into the Mal'cev class of distributive varieties.



**Theorem 3.5.** *Let  $\mathcal{V}$  be a variety of left quasigroups. The following are equivalent:*

- (i)  $\mathcal{V}$  is congruence meet-semidistributive.
- (ii)  $\mathcal{V}$  is congruence distributive.
- (iii)  $\mathcal{V}$  is congruence arithmetic.

According to Theorems 3.2 and 3.5, for left quasigroups the poset of Mal'cev classes in Figure 1 turns into the one in Figure 2.

A term  $t(x_1, \dots, x_n)$  in the language of left quasigroups is a well-formed formal expression using the variables  $x_1, \dots, x_n$  and the operations  $\{*, \backslash\}$ . It is easy to see that the term  $t$  is either a variable or can be expressed by

$$t(x_1, \dots, x_n) = u(x_1, \dots, x_n) \bullet r(x_1, \dots, x_n) \tag{1}$$

where  $\bullet \in \{*, \backslash\}$  and  $u$  and  $r$  are suitable subterms. Let  $u$  be a  $n$ -ary term. We define

$$\begin{aligned} L_{u(x_1, \dots, x_n)}^0(y) &= y \\ L_{u(x_1, \dots, x_n)}^{k+1}(y) &= u(x_1, \dots, x_n) * L_{u(x_1, \dots, x_n)}^k(y), \\ L_{u(x_1, \dots, x_n)}^{k-1}(y) &= u(x_1, \dots, x_n) \backslash L_{u(x_1, \dots, x_n)}^k(y), \end{aligned}$$

for  $k \in \mathbb{Z}$ . Using this notation we have that every term  $t$  can be written as

$$t(x_1, \dots, x_n) = L_{u_1(x_1, \dots, x_n)}^{k_1} \dots L_{u_m(x_1, \dots, x_n)}^{k_m}(x_R)$$

where  $u_i$  is a subterm,  $k_i = \pm 1$  for  $1 \leq i \leq m$  and  $x_R \in \{x_i : i = 1, \dots, n\}$ . We say that  $x_R$  is the *rightmost variable of  $t$* .

Every identity in the language of left quasigroups  $t_1 \approx t_2$  has the form

$$L_{w_1(x_1, \dots, x_n)}^{k_1} \dots L_{w_m(x_1, \dots, x_n)}^{k_m}(x_R) \approx L_{u_1(y_1, \dots, y_l)}^{r_1} \dots L_{u_l(y_1, \dots, y_l)}^{r_l}(y_R),$$

or equivalently,

$$L_{u_l(y_1, \dots, y_l)}^{-r_l} \dots L_{u_1(y_1, \dots, y_l)}^{-r_1} L_{w_1(x_1, \dots, x_n)}^{k_1} \dots L_{w_m(x_1, \dots, x_n)}^{k_m}(x_R) \approx y_R. \tag{2}$$

The projection left quasigroup  $\mathcal{P}_2$  satisfies (2) if and only if  $x_R = y_R$ . So a variety of left quasigroups  $\mathcal{V}$  has a Mal'cev term if and only if it satisfies an identity as in (2) with  $x_R \neq y_R$ .

Note that, an identity as in (2) might have just the trivial model. For instance if  $\mathcal{V}$  is a variety of idempotent left quasigroups satisfying such an identity and the variable  $y_R$  does not appear in the left handside then  $\mathcal{V}$  is trivial. Indeed, identifying all the variables  $x_1, \dots, x_n, y_1, \dots, y_l$  we have  $L_{x_R}^{k_1 + \dots + k_m}(x_R) = x_R \approx y_R$ .

**Example 3.6.** A variety axiomatized by some identities as in (2) might be made up of latin left quasigroups. For instance, Mal'cev varieties of left quasigroups are provided by varieties of quasigroup in which every member is *term equivalent* to its left quasigroup reduct. This is the case of the following examples (for an example of a Mal'cev variety of latin left quasigroups not arising from quasigroups see Proposition 4.2).

- (i) The variety of commutative left quasigroups defined by the identity

$$x * y \approx y * x.$$

- (ii) Let  $n \in \mathbb{N}$ . The variety of left quasigroups satisfying the identity

$$(\dots \underbrace{((x * y) * y) \dots}_n) * y \approx x.$$

- (iii) The variety of paramedial left quasigroups, identified by the identity

$$(x * y) * (z * t) \approx (t * y) * (z * x).$$

**Example 3.7.** Mal'cev varieties of left quasigroups are not limited to varieties of latin left quasigroups, as witnessed by the following examples.

- (i) Let  $\mathcal{V}_n$  be the variety of left quasigroups satisfying  $L_x^n(x) \approx L_y^n(y)$  where  $n \in \mathbb{Z}$ . Then

$$m(x, y, z) = L_x^{-n} L_y^n(z)$$

is a Mal'cev term. Let  $n > 0$ ,  $Q$  be a set and  $e$  be a fixed element in  $Q$ . We define  $L_e = 1$  and  $L_a$  to be any cycle  $(a, \dots, e)$  of length  $n$  for every  $a \in Q$ ,  $a \neq e$  (if  $n < 0$  we define  $L_a^{-1}$  in the same way). Then  $(Q, *) \in \mathcal{V}_n$ .

- (ii) The variety of  $n$ -multipotent left quasigroups is axiomatized by the identity

$$\mathfrak{s}^n(x) = L_{\mathfrak{s}^{n-1}(x)} L_{\mathfrak{s}^{n-2}(x)} \dots L_{\mathfrak{s}(x)} L_x(x) \approx L_{\mathfrak{s}^{n-1}(y)} L_{\mathfrak{s}^{n-2}(y)} \dots L_{\mathfrak{s}(y)} L_y(y) = \mathfrak{s}^n(y).$$

A Mal'cev term for  $n$ -multipotent left quasigroups is

$$m(x, y, z) = (L_{\mathfrak{s}^{n-2}(x)} \dots L_{\mathfrak{s}(x)} L_x)^{-1} L_{\mathfrak{s}^{n-2}(y)} \dots L_{\mathfrak{s}(y)} L_y(z).$$

**Example 3.8.** Let  $\mathfrak{G}$  be a variety of groups. We denote the class of left quasigroups such that the left multiplication group (resp. displacement group) belongs to  $\mathfrak{G}$  by  $L(\mathfrak{G})$  (resp.  $D(\mathfrak{G})$ ). According to Lemma 2.1 such classes are varieties. Since  $\text{LMlt}(\mathcal{P}_2) = \text{Dis}(\mathcal{P}_2) = 1$  then  $\mathcal{P}_2$  belongs to  $L(\mathfrak{G})$  and to  $D(\mathfrak{G})$  and so they have no Mal'cev term.

## 4. Semimedial left quasigroups

*Semimedial* left quasigroups are defined by the semimedial law:

$$(x * y) * (x * z) \approx (x * x) * (y * z).$$

The projection left quasigroup  $\mathcal{P}_2$  satisfies the semimedial law and so the whole variety of semimedial left quasigroups is not Mal'cev.

A relevant subvariety of 2-divisible semimedial left quasigroups is the variety of *racks*, axiomatized by the identity

$$x * (y * z) \approx (x * y) * (x * z).$$

Idempotent semimedial left quasigroups are racks and they are called *quandles*. If  $Q$  is semimedial then the squaring map  $\mathfrak{s}$  is a homomorphism and so if  $h = L_{a_1}^{k_1} \dots L_{a_n}^{k_n} \in \text{LMlt}(Q)$  we have

$$\mathfrak{s}h = \underbrace{L_{\mathfrak{s}(a_1)}^{k_1} \dots L_{\mathfrak{s}(a_n)}^{k_n}}_{=h^{\mathfrak{s}}} \mathfrak{s}$$

and the subset  $E(Q) = \{a \in Q : a * a = a\}$  is a subquandle of  $Q$ . *Medial* left quasigroups, i.e. those for which

$$(x * y) * (z * t) \approx (x * z) * (y * t)$$

holds are also semimedial.

For a semimedial left quasigroup  $Q$ , the admissible subgroups are

$$\text{Norm}(Q) = \{N \trianglelefteq \text{LMlt}(Q) : N^{\mathfrak{s}} \leq N\}$$

where  $N^{\mathfrak{s}} = \{h^{\mathfrak{s}} : h \in N\}$ . Note that  $[g, h]^{\mathfrak{s}} = [g^{\mathfrak{s}}, h^{\mathfrak{s}}]$  for every  $g, h \in \text{LMlt}(Q)$ . Thus, if  $N \in \text{Norm}(Q)$  then  $[\text{LMlt}(Q), N] \in \text{Norm}(Q)$  (see [5, Lemma 3.1]).

The relation  $\text{con}_N$  is a congruence for every admissible subgroup  $N$  and the assignments  $\alpha \mapsto \text{Dis}_\alpha$  and  $N \mapsto \text{con}_N$  provide a second monotone Galois connection between the lattice of congruences and the admissible subgroups [5, Theorem 3.5]. Such a Galois connection is also well-behaved with respect to the commutator of congruences. Indeed, in a Mal'cev variety the commutator of congruences in the sense of [11] is completely determined by such Galois connection.

**Lemma 4.1.** *Let  $\mathcal{V}$  be a Mal'cev variety of semimedial left quasigroups and  $Q \in \mathcal{V}$ . Then*

$$[\alpha, \beta] = \text{con}_{[\text{Dis}_\alpha, \text{Dis}_\beta]}$$

for every  $\alpha, \beta \in \text{Con}(Q)$ .

*Proof.* The variety  $\mathcal{V}$  is Cayley ([5, Proposition 3.6]), and so the left quasigroups in it are superfaithful by Proposition 3.4(i). Therefore we can apply directly [5, Proposition 3.10] □

Let us show that unipotent semimedial left quasigroups are latin, providing an example of variety of latin left quasigroups that is not term equivalent to a variety of quasigroups. Recall that a group  $G$  acting on a set  $Q$  is *regular* if for every  $a, b \in Q$  there exists a unique  $g \in G$  such that  $b = g \cdot a$ . Equivalently the action is transitive and the pointwise stabilizers are trivial.

**Proposition 4.2.** *Let  $Q$  be a unipotent semimedial left quasigroup and  $\mathfrak{s}(Q) = \{e\}$ . Then:*

- (i) *the group  $\text{Dis}(Q)$  is regular and  $\text{Dis}(Q) = \{L_a L_e^{-1} : a \in Q\}$ .*
- (ii)  *$Q$  is latin.*

*Proof.* (i). Let  $h = L_{a_1}^{k_1} \dots L_{a_n}^{k_n} \in \text{Dis}(Q)$ . According to [5, Lemma 1.4]  $k_1 + \dots + k_n = 0$  and so  $h^{\mathfrak{s}} = L_{\mathfrak{s}(a_1)}^{k_1} \dots L_{\mathfrak{s}(a_n)}^{k_n} = L_e^{k_1 + \dots + k_n} = 1$ . If  $h \in \text{Dis}(Q)_a$ , then  $L_a = L_{h(a)} = h^{\mathfrak{s}} L_a h^{-1} = L_a h^{-1}$ , i.e.  $h = 1$  and so  $\text{Dis}(Q)$  is regular. On the other hand,  $e = (e \setminus a) * (e \setminus a) = L_{e \setminus a} L_e^{-1}(a)$ , and so we have  $\text{Dis}(Q) = \{L_a L_e^{-1} : a \in Q\}$ .

(ii). Let  $a, b \in Q$ . According to (i)  $\text{Dis}(Q) = \{L_c L_e^{-1} : c \in Q\}$  and it is regular. Thus, there exists a unique  $c$  such that

$$a = L_c L_e^{-1}(b) = c * (e \setminus b)$$

and so the right multiplication  $R_{e \setminus b}$  is bijective for every  $b \in Q$ .  $\square$

#### 4.1. Congruence distributive varieties

According to Theorem 3.5 we have that congruence meet-semidistributive varieties of left quasigroups are congruence distributive. For semimedial left quasigroups congruence distributivity is determined by the properties of the relative displacement groups and of the admissible subgroups.

**Proposition 4.3.** *Let  $\mathcal{V}$  be a variety of semimedial left quasigroups. The following are equivalent:*

- (i)  $\mathcal{V}$  is distributive.
- (ii)  $\text{Dis}_\alpha = [\text{Dis}_\alpha, \text{Dis}_\alpha]$  for every  $Q \in \mathcal{V}$  and  $\alpha \in \text{Con}(Q)$ .
- (iii) If  $N \in \text{Norm}(Q)$  is solvable then  $N = 1$  for every  $Q \in \mathcal{V}$ .

*Proof.* It is enough to prove the equivalence for meet-semidistributive varieties thanks to Theorem 3.5.

Let  $Q \in \mathcal{V}$  and  $\alpha \in \text{Con}(Q)$ . By Lemma 4.1 we have

$$\text{Dis}_{[\alpha, \alpha]} = \text{Dis}_{\text{con}[\text{Dis}_\alpha, \text{Dis}_\alpha]} \leq [\text{Dis}_\alpha, \text{Dis}_\alpha] \leq \text{Dis}_\alpha.$$

(i)  $\Rightarrow$  (ii). By Theorem 1.1 we have  $[\alpha, \alpha] = \alpha$  and so  $\text{Dis}_\alpha = \text{Dis}_{[\alpha, \alpha]} = [\text{Dis}_\alpha, \text{Dis}_\alpha]$ .

(ii)  $\Rightarrow$  (iii). Let  $N \in \text{Norm}(Q)$  be solvable of length  $n$  and let  $D$  be the non-trivial  $(n-1)$ th element of the derived series of  $N$ . So  $D$  is abelian and it is in  $\text{Norm}(Q)$ . Hence, according to [5, Lemma 2.6],  $\beta = \mathcal{O}_D$  is a non-trivial abelian congruence of  $Q$ . Therefore  $\text{Dis}_\beta$  is abelian and we have  $\text{Dis}_\beta = [\text{Dis}_\beta, \text{Dis}_\beta] = 1$ . Hence,  $\beta \leq \lambda_Q = 0_Q$ , contradiction.

(iii)  $\Rightarrow$  (i). If  $\alpha$  is abelian then  $\text{Dis}_\alpha$  is abelian [8, Corollary 5.4]. Hence  $\text{Dis}_\alpha = [\text{Dis}_\alpha, \text{Dis}_\alpha] = 1$ , i.e.  $\alpha \leq \lambda_Q = 0_Q$ .  $\square$

If  $Q$  is a 2-divisible semimedial left quasigroup then

$$\text{Norm}(Q) = \{N \trianglelefteq \text{LMlt}(Q) : \mathfrak{s}N\mathfrak{s}^{-1} \leq N\}$$

since  $\mathfrak{s}$  is bijective. In particular,  $Z(N)$  is a characteristic subgroup of  $N$ , and so it is normal in  $\text{LMlt}(Q)$  and  $\mathfrak{s}Z(N)\mathfrak{s}^{-1} \leq Z(N)$ . Thus,  $Z(N) \in \text{Norm}(Q)$ .

**Proposition 4.4.** *Let  $\mathcal{V}$  be a variety of 2-divisible semimedial left quasigroups. The following are equivalent*

- (i)  $\mathcal{V}$  is distributive
- (ii)  $Z(N) = 1$  for every  $Q \in \mathcal{V}$  and every  $N \in \text{Norm}(Q)$ .

*Proof.* We are using the characterization of distributive varieties given in Proposition 4.3(iii).

(i)  $\Rightarrow$  (ii). If  $N \in \text{Norm}(Q)$ , then  $Z(N) \in \text{Norm}(Q)$  is solvable and so  $Z(N) = 1$ .

(ii)  $\Rightarrow$  (i). If  $Z(N) = 1$  for every  $N \in \text{Norm}(Q)$  then there are no abelian subgroups in  $\text{Norm}(Q)$ . Since  $[N, N] \in \text{Norm}(Q)$  for every  $N \in \text{Norm}(Q)$  then there are no solvable subgroup in  $\text{Norm}(Q)$ .  $\square$

**Corollary 4.5.** *Let  $\mathcal{V}$  be a distributive variety of semimedial left quasigroups. Then:*

- (i)  $\mathcal{V}$  does not contain any non-trivial medial left quasigroup.
- (ii)  $\mathcal{V}$  does not contain any non-trivial finite 2-divisible latin left quasigroup.

*In particular, there is no distributive variety of medial left quasigroups.*

*Proof.* The variety  $\mathcal{V}$  omits solvable algebras. Medial left quasigroups are nilpotent [5, Corollary 4.4] and finite 2-divisible latin semimedial left quasigroups are solvable [5, Corollary 3.20].  $\square$

### 4.2. Mal'cev varieties of quandles

In this Section we focus on quandles. A remarkable construction of quandles is the following.

**Example 4.6.** (cf. [16]) Let  $G$  be a group,  $f \in \text{Aut}(G)$  and a subgroup  $H \leq \text{Fix}(f) = \{a \in G : f(a) = a\}$ . Let  $G/H$  be the set of left cosets of  $H$  and the multiplication defined by

$$aH * bH = af(a^{-1}b)H.$$

Then  $\mathcal{Q}(G, H, f) = (G/H, *, \setminus)$  is a quandle, called a *coset quandle*. A coset quandle  $\mathcal{Q}(G, H, f)$  is called *principal* if  $H = 1$  and in such case it is denoted by  $\mathcal{Q}(G, f)$ . A principal quandle is called *affine* if  $G$  is abelian and in such case it is denoted by  $\text{Aff}(G, f)$ .

Connected quandles can be represented as coset quandles over their displacement group.

**Proposition 4.7.** [14, Theorem 4.1] *Let  $Q$  be a connected quandle  $Q$ . Then  $Q$  is isomorphic to  $\mathcal{Q}(\text{Dis}(Q), \text{Dis}(Q)_a, \widehat{L}_a)$  for every  $a \in Q$ , where  $\widehat{L}_a : \text{Dis}(Q) \rightarrow \text{Dis}(Q)$  is defined by setting  $x \mapsto L_a x L_a^{-1}$  for every  $x \in \text{Dis}(Q)$ .*

The class of latin quandles is not a subvariety of the variety of quandles. Indeed the non-connected quandle  $\text{Aff}(\mathbb{Z}, -1)$  embeds into the latin quandle  $\text{Aff}(\mathbb{Q}, -1)$ . On the other hand, the class of principal quandles of a Mal'cev variety is a subvariety.

**Theorem 4.8.** *The class of principal quandles of a Mal'cev variety  $\mathcal{V}$  is a subvariety of  $\mathcal{V}$ .*

*Proof.* The product of principal quandles is principal [4, Corollary 2.3]. By virtue of [6, Proposition 2.11] subquandles and factors of principal Mal'cev quandles are principal. Hence the class of principal quandles of  $\mathcal{V}$  is a subvariety.  $\square$

`SmallQuandle(28,i)` for  $i = 3, 4, 5, 6$  are the smallest examples of non-latin superconnected quandles in the [13] library of GAP. The identities in Table 1 provide Mal'cev varieties of quandles that contain such minimal examples.

Table 1: Examples of Mal'cev varieties of quandles

Identity	Witness in the RIG library
$L_x L_y^2 L_x L_y L_x^2 L_y L_x L_y^2(x) \approx y$	<code>SmallQuandle(28,3)</code>
$L_x^2 L_y L_x L_y^2 L_x L_y L_x^2 L_y^2(x) \approx y$	<code>SmallQuandle(28,4)</code>
$L_x L_y^2 L_x L_y L_x^2 L_y L_x L_y^2(x) \approx y$	<code>SmallQuandle(28,5)</code>
$L_x L_y^2 L_x L_y L_x^2 L_y L_x L_y^2(x) \approx y$	<code>SmallQuandle(28,6)</code>

Distributive varieties of quandles have the following characterization.

**Theorem 4.9.** *Let  $\mathcal{V}$  be a variety of quandles. The following are equivalent:*

- (i)  $\mathcal{V}$  contains a non-trivial abelian quandle.
- (ii)  $\mathcal{V}$  has a non-trivial finite model.

*In particular,  $\mathcal{V}$  is distributive if and only if  $\mathcal{V}$  has no non-trivial finite model.*

*Proof.* (i)  $\Rightarrow$  (ii). According to [4, Theorem 3.21] simple abelian quandles are finite. Let  $Q \in \mathcal{V}$  be a non-trivial abelian quandle. According to the main result of [?],  $\mathcal{V}(Q) \subseteq \mathcal{V}$  contains a simple abelian quandle which is finite.

(ii)  $\Rightarrow$  (i). Let assume that  $\mathcal{V}$  contains a non-trivial finite quandle  $Q$ . According to [4, Theorem 4.7], the minimal subquandles of  $Q$  with respect to inclusion are abelian.

The variety  $\mathcal{V}$  is idempotent, and so it contains an abelian congruence if and only if it contains an abelian algebra. Thus, the last claim follows.  $\square$

**Corollary 4.10.** *Let  $\mathcal{V}$  be a distributive variety of semimedial left quasigroups and  $Q \in \mathcal{V}$ . If  $E(Q)$  is finite then  $|E(Q)| = 1$ .*

*Proof.* According to Theorem 4.9 if  $E(Q)$  is finite then  $\mathcal{V}(E(Q))$  contains an abelian algebra.  $\square$

*Involutory* quandles are the quandles that satisfy the identity  $x(xy) \approx y$ . A direct consequence of the contents of [6, Section 3] is that connected involutory quandles on two generators are finite, so we have the following Corollary of Theorem 4.9.

**Corollary 4.11.** *There is no distributive variety of involutory quandles.*

**Acknowledgements.** The first author would like to thank Professor David Stanovský for introducing him to the topic and Professor Paolo Aglianò for the useful discussions and remarks about the present paper.

## References

- [1] **L. Barto, M. Kozik, and D. Stanovský**, Mal'tsev conditions, lack of absorption, and solvability, *Algebra Universalis*, **74** (2015), 185–206.
- [2] **C. Bergman**, *Universal algebra, Pure and Applied Mathematics (Boca Raton)*, Fundamentals and selected topics. CRC Press, Boca Raton, FL, **301**(2012). Fundamentals and selected topics.
- [3] **M. Bodirski**, *Mal'cev condition figure*, [https://www.math.tu-dresden.de/bodirsky/Maltsev-Conditions/\(2021\)](https://www.math.tu-dresden.de/bodirsky/Maltsev-Conditions/(2021)).
- [4] **M. Bonatto**, *Principal and doubly homogeneous quandles*, *Monatshefte für Mathematik*, **191** (2020), no. 4, 691–717.
- [5] **M. Bonatto**, *Medial and semimedial left quasigroups*, *J. Algebra*, available as 10.1142/S0219498822500219 (2021).
- [6] **M. Bonatto**, *Superconnected left quasigroups and involutory quandles*, arXiv e-prints (2021).
- [7] **M. Bonatto and D. Stanovský**, *A universal algebraic approach to rack coverings*, arXiv:1910.09317 (2019).
- [8] **M. Bonatto and D. Stanovský**, *Commutator theory for racks and quandles*, *J. Math. Soc. Japan*, **73** (2021), 41–75.
- [9] **B. Csakany**, *Characterizations of regular varieties*, *Acta Sci. Math. (Szeged)*, **31** (1970), 187–189.
- [10] **A. Day**, *A characterization of modularity for congruence lattices of algebras*, *Canad. Math. Bull.*, **12** (1969), 167–173.
- [11] **R. Freese and R. McKenzie**, *Commutator theory for congruence modular varieties*, *London Math. Soc. Lecture Note Series*, Cambridge, **125** (1987).
- [12] **D. Geiger**, *Coherent algebras*, *Notices Amer. Math. Soc.*, **21** (1974).
- [13] **M. Graña and L. Vendramin**, *Rig*, a GAP package for racks, quandles and Nichols algebras.
- [14] **A. Hulpke, D. Stanovský, and P. Vojtěchovský**, *Connected quandles and transitive groups*, *J. Pure Appl. Algebra*, **220** (2016), no. 2, 735–758.
- [15] **B. Jonsson**, *Algebras whose congruence lattices are distributive*, *Math. Scandinav.*, **21** (1967), 110–121.
- [16] **D. Joyce**, *A classifying invariant of knots, the knot quandle*, *J. Pure Appl. Algebra*, **23** (1982), no. 1, 37–65.
- [17] **K.A. Kearnes and E.W. Kiss**, *The shape of congruence lattices*, *Mem. Amer. Math. Soc.*, **222** (2013).

- [18] **A.I. Mal'cev**, *On the general theory of algebraic systems*, Amer. Math. Soc. Transl. (2), **27** (1963), 125–142.
- [19] **S.V. Matveev**, *Distributive groupoids in knot theory*, Mat. Sb. (N.S.), **119** (1982), no. 1, 78–88.
- [20] **W. McCune**, Prover9 and mace4. <http://www.cs.unm.edu/~mccune/prover9/>, 2005–2010.
- [21] **R. McKenzie and D. Hobby**, *The structure of finite algebras*, Contemporary Math., **76** (1988).
- [22] **M. Olšák**, *The weakest nontrivial idempotent equations*, Bull. Lond. Math. Soc., **49** (2017), no. 6, 1028–1047.
- [23] **M. Olšák**, *Maltsev conditions for general congruence meet-semidistributive algebras*, arXiv:1810.03178(2018).
- [24] **A.F. Pixley**, *Distributivity and permutability of congruence relations in equational classes of algebras*, Proc. Amer. Math. Soc., **14** (1963), 105–109.
- [25] **A.F. Pixley**, *Local Mal'cev conditions*, Canad. Math. Bull., **15** (1972), 559–1568.
- [26] **W. Taylor**, *Uniformity of congruences*, Algebra Universalis, **4** (1974), 342–360.
- [27] **W. Taylor**, *Varieties obeying homotopy laws*, Canad. J. Math., **29** (1977), no. 3, 498–527.
- [28] **R. Wille**, *Kongruenzklassengeometrien*, Lecture Notes Math., Springer, **113** (1970).

Received March 25, 2021

M. Bonatto  
Dipartimento di matematica e informatica - UNIFE  
Ferrara, Italy  
e-mail: marco.bonatto.87@gmail.com

S. Fioravanti  
DIISM  
Università degli Studi di Siena  
Siena, Italy  
e-mail: stefano.fioravanti66@gmail.com